



FESTA

PROFESSIONELLE  HANDWERKZEUGE



20
25
—
26

FESTA
POWER X TOOLS

Elektrische Werkzeuge und Akku-Werkzeuge unter Verwendung hochwertiger Komponenten, neuester Technologien und aktueller Trends in diesem Sortiment

FESTA

Marke für professionelles Handwerkzeug für den Bau, die Werkstatt und den Garten.

FESTA
INDUSTRY

Premium-Serie ausgewählter Werkzeuge und Handwerkzeuge höchster Qualität, entwickelt für anspruchsvolle Arbeitsbedingungen, bei denen Leistung im Vordergrund steht.

FESTA
AQUATIC

Professionelles Bewässerungssortiment in modernem Design, kompatibel mit der Rosa - Produktlinie

HORIZONT
MASTER

Marke von höchster Qualität

HORIZONT

Marke von hoher Qualität für Maurer

ROSA

Hochwertige Bewässerungssysteme und Gartengeräte

KDS[®]

Japanische Messer mit langer Tradition

KOMELON[®]

Professionelle Maßbänder



Professionelle Fliesenschneider



Hersteller hochwertiger Gartenscheren

Lescha

Professionelle Baumischer

Stahlberg

Marke professioneller Sägen



Marke professioneller Sägen

AKKU- UND ELEKTROWERKZEUGE

2 - 53



SCHNEID-UND SCHLEIFWERKZEUG

54 - 93



WERKSTATTWERKZEUG

94 - 205



WERKSTATT

206 - 241



BAUGERÄTE

242 - 307



GARTENWERKZEUG

308 - 359



FESTA

360 - 365



INDEX

366 - 380



4

BOHRER



9

BOHRHAMMER



10

NAGLER UND TACKER



11

WINKELSCHLEIFER



12

EXZENTERSCHLEIFER



13

HANDKREISSÄGE



15

LUFTKOMPRESSOR



16

FLIESEN
VIBRATIONS-
NIVELLIERMASCHINE



17

KARTUSCHENPISTOLE



17

LED-BAUSTRAHLER



18

RADIO DAB+ / FM / BT



23

BOHRHAMMER



26

HANDKREISSÄGE



27

WINKELSCHLEIFER



36

TROCKENBAUSCHLEIFER



37

STAUBSAUGER



38

ELEKTRISCHES RÜHRWERK



39

HOCHDRUCKREINIGER



40

STYROPORSCHNEIDER



43

SCHWEISSINVERTER



45

SPAWACZE POLIFUZYJNE



46

KOMPRESSOREN
UND ZUBEHÖR



50

HEISSLUFTPISTOLEN



52

HEIZUNGEN



53

VERLÄNGERUNGSKABEL



ELEKTROWERKZEUGE 2 - 53



FESTA
POWER X TOOLS

BRUSHLESS **SHARE** **20V** *Li-ion technology*

Verstellfunktion
0-550 min⁻¹
0-2000 min⁻¹

Masse
mit Batterie 2,0 Ah **1,8 kg**
mit Batterie 4,0 Ah **2,1 kg**

Drehmoment
80 Nm

Bohrfutter
2 - 13 mm



- Das Set enthält:
- Schlagbohrer
 - 2.0 Ah Batterie
 - 4.0 Ah Batterie
 - 2.4 A Ladegerät
 - Zusätzlicher Handgriff
 - Koffer



AKKUBOHRER MIT HAMMER

max 80 Nm		I.0-8800bpm II.0-32000bpm	I.0-550min ⁻¹ II.0-2000min ⁻¹		 2-13 mm			 1,4 kg	 2x	
--------------	--	------------------------------	--	--	-------------	--	--	------------	--------	--

Nr. 28000 spezifikation

BRUSHLESS SHARE 20V *Li-ion technology*

Verstellfunktion
0-550 min⁻¹
0-2000 min⁻¹

Masse
mit Batterie 2,0 Ah **1,8 kg**
mit Batterie 4,0 Ah **2,1 kg**

Drehmoment
80 Nm

Bohrfutter
2 – 13 mm

- Das Set enthält:
- Schlagbohrer
 - 2.0 Ah Batterie
 - 2.4 A Ladegerät
 - Zusätzlicher Handgriff
 - Koffer



Modusauswahl
Wahl der Drehmomentkraft

Zusätzlicher Handgriff

Schnelles Öffnen des
Bohrfutterkopfes

Ergonomischer gummierter
Griff für einen bequemen
und sicheren Halt

LED-Beleuchtung

Batterieschloss



Verstellbarer Schalter

Drehrichtungsschalter

Haken zum
Aufhängen



AKKUBOHRER MIT HAMMER

max 80 Nm		I.0-8800 bpm II.0-32000 bpm	I.0-550 min ⁻¹ II.0-2000 min ⁻¹				LED		1,8 / 1,4	1x	Li-ion
--------------	--	--------------------------------	--	--	--	--	-----	--	-----------	----	--------

40 min

2

Nr. 28001 spezifikation

BRUSHLESS SHARE 20V

Verstellfunktion
0-550 min⁻¹
0-2000 min⁻¹

Masse ohne
Batterie
1,4 kg

Drehmoment
80 Nm

Bohrfutter
2 – 13 mm

Zubehör

- SHARE 20V** *Li-ion technology*
- Batterie* 2 Ah - 28080
 - 4 Ah - 28081
 - 8 Ah - 28083
 - Ladegerät* 2,4 A - 28085
 - 4,0 A - 28086

Modusauswahl
Wahl der Drehmomentkraft

Zusätzlicher Handgriff

Schnelle
Veröffentlichung
Bohrfutterkopf

Ergonomischer gummierter
Griff für einen bequemen
und sicheren Halt

LED-Beleuchtung



Verstellbarer Schalter

Richtung
des Rotationsschalters

Haken zum
Aufhängen



AKKUBOHRER MIT HAMMER

max 80 Nm		I.0-8800 bpm II.0-32000 bpm	I.0-550 min ⁻¹ II.0-2000 min ⁻¹				LED		1,4
--------------	--	--------------------------------	--	--	--	--	-----	--	-----

*Batterie und Ladegerät nicht enthalten

Nr. 28002 spezifikation

5

**SHARE
20V**

**Li-ion
technology**

Verstellfunktion
0-500 min⁻¹
0-1800 min⁻¹

Masse
mit Batterie 2,0 Ah
1,7 kg

Drehmoment
45 Nm

Bohrfutter
2 – 13 mm

Das Set enthält:

- Schlagbohrer
- 2x 2.0 Ah Batterien
- 2.4 A Ladegerät
- Koffer
- Träger und Bits:

- ⊖ S5, S6 x 25 mm
- ⊕ PH1, PH2 x 25 mm
- ✳ PZ1, PZ2 x 25 mm
- HSS Bohrer
2-2.5-3-4-5-6 mm



FESTA
POWER X TOOLS

AKKUBOHRER MIT HAMMER

max 45 Nm		0-19200 bpm	0-500min ⁻¹ 0-1800min ⁻¹							
--------------	--	----------------	---	--	--	--	--	--	--	--



Nr. spezifikation

28003

3

**SHARE
20V**

Verstellfunktion
0-550 min⁻¹
0-2000 min⁻¹

Masse ohne
Batterie
1,4 kg

Drehmoment
45 Nm

Bohrfutter
2 – 13 mm

Zubehör

**SHARE
20V**
**Li-ion
technology**

Batterie*

2 Ah - 28080

4 Ah - 28081

8 Ah - 28083

Ladegerät*

2,4 A - 28085

4,0 A - 28086



Modusauswahl
Wahl der Drehmomentkraft

Schnelles Öffnen des
Bohrfutterkopfes

Ergonomischer gummierter
Griff für einen bequemen
und sicheren Halt

LED-Beleuchtung



Verstellbarer Schalter

Drehrichtung

Haken zum
Aufhängen

FESTA
POWER X TOOLS

AKKUBOHRER MIT HAMMER

max 45 Nm		0-19200 bpm	0-500min ⁻¹ 0-1800min ⁻¹					
--------------	--	----------------	---	--	--	--	--	--

*Batterie und Ladegerät nicht enthalten

Nr. spezifikation

28004

5

SHARE
20V *Li-ion*
technology

Verstellfunktion
0-350 min⁻¹
0-1300 min⁻¹

Masse mit Batterie 2,0 Ah
1,3 kg

Drehmoment
28 Nm

Bohrfutter
1 - 10 mm

- Das Set enthält:
- Schlagbohrer
 - 2x 2.0 Ah Batterien
 - 2.4 A Ladegerät
 - Koffer
 - Träger und Bits:
 - ⊖ S5, S6 x 25 mm
 - ⊕ PH1, PH2 x 25 mm
 - ⊕ PZ1, PZ2 x 25 mm
 - Bohrer HSS
 - 1,5-2,5-3-4-5-6 mm



AKKUSCHRAUBER BOHREN

max 28 Nm		0-350min ⁻¹ 0-1300min ⁻¹		1-10 mm		LED	1,3 / 0,9	2x	Li-ion
-----------	--	---	--	---------	--	-----	-----------	----	--------

Nr. 28005 spezifikation



SHARE
20V

Verstellfunktion
0-350 min⁻¹
0-1300 min⁻¹

Masse ohne Batterie
0,9 kg

Drehmoment
28 Nm

Bohrfutter
1 - 10 mm

Zubehör

- SHARE**
20V *Li-ion*
technology
- Batterie* 2 Ah - 28080
 - 4 Ah - 28081
 - 8 Ah - 28083
 - Ladegerät* 2,4 A - 28085
 - 4,0 A - 28086



AKKUSCHRAUBER BOHREN

max 28 Nm		0-350min ⁻¹ 0-1300min ⁻¹		1-10 mm		LED	0,9
-----------	--	---	--	---------	--	-----	-----

*Batterie und Ladegerät nicht enthalten

Nr. 28006 spezifikation



Modusauswahl
Wahl der Drehmomentkraft

Schnelles Öffnen des
Bohrfutterkopfes

Ergonomischer gummierter
Griff für einen bequemen
und sicheren Halt

LED-Beleuchtung

Batterieschloss

Verstellbarer Schalter

Drehrichtungsschalter

Haken zum
Aufhängen



Li-ion
technology

Verstellfunktion
0-350 min⁻¹
0-1300 min⁻¹

Masse
mit Batterie 1,5 Ah
1 kg

Drehmoment
20 Nm

Bohrfutter
1 - 10 mm

- Das Set enthält:
- Schlagbohrer
 - 2x Batterien 12 V | 1.5 Ah
 - Ladegerät 12 V | 2.4 A
 - Koffer
 - Träger und Bits:
 - ⊖ S5, S6 x 25 mm
 - ⊕ PH1, PH2 x 25 mm
 - ⊕ PZ1, PZ2 x 25 mm
 - Bohrer HSS
 - 1,5-2,5-3-4-5-6 mm



Modusauswahl
Wahl der Drehmomentkraft

Schnelles Öffnen des
Bohrfutterkopfes

Verstellbarer Schalter

LED-Beleuchtung

Batterieladeanzeige

Drehrichtung

Ergonomischer gummierter
Griff für einen bequemen
und sicheren Halt

Batterie



FESTA
POWER X TOOLS

AKKUSCHRAUBER BOHREN

max 20 Nm | 1-10 mm | 0-350/0-1300 min⁻¹ | LED | 1 | 2x | Li-ion



Nr. 28007 spezifikation

5

Li-ion
technology

Revolutionieren
ohne Last
200 min⁻¹

Masse
mit Batterie 1,5 Ah
0,4 kg

Maximales
Drehmomen
3 Nm

Werkzeugträger
1/4" hexagon

- Das Set enthält:
- akkuschauber
 - Ladegerät 5 V | 0,5 A
 - Träger und Bits:
 - ⊖ S5 x 50 mm
 - ⊕ PH1 x 50 mm
 - ⊕ PH2 x 50 mm
 - H5 x 50 mm
 - ⊕ T20 x 50 mm

1/4" Schnellwechsekopf
mit Sicherung

Einstellungen Drehmoment

Batterieladeanzeige

Einstellsperre der
Handgriffposition

LED-Beleuchtung

Drehrichtungsschalter

Ergonomisch gummiert
Griff für einen bequemen
und sicheren Halt



LED-Beleuchtung

FESTA
POWER X TOOLS

AKKUSCHRAUBER

max 3 Nm | 200 min⁻¹ | 1/4" | LED | 0,4 kg | Li-ion | 3,6 V | 1,5 Ah



Nr. 28008 spezifikation

10

**SHARE
20V**

Revolutionieren
ohne Last
0-2000 min⁻¹

Masse ohne
Batterie
1,2 kg

Drehmoment
150 Nm

Anzahl
der Schläge
0-3000 bpm

1/4" Schnellwechselkopf
mit Sicherung



Wählbar Drehrichtung

Ergonomisch gummiert
Griff für einen bequemen
und sicheren Halt

LED-Beleuchtung

Haken zum Aufhängen

Zubehör

**SHARE
20V
Li-ion
technology**

Batterie* 2 Ah - 28080
4 Ah - 28081
8 Ah - 28083

Ladegerät* 2,4 A - 28085
4,0 A - 28086



AKKU-BOHRSCHRAUBER

max 150 Nm | 0-2000min⁻¹ | 0-3000bpm | 1/4" | L R | LED | 1,2 KG

*Batterie und Ladegerät nicht enthalten

Nr. 28021 spezifikation



5

**SHARE
20V**

Revolutionieren
ohne Last
**I.0-300 min⁻¹
II.0-1000 min⁻¹**

Masse ohne
Batterie
1,7 kg

Anzahl der Treffer
0-5000 bpm

Handgriff
SDS+

Tiefenanschlag

SDS-Klemmung
Werkzeugkopf

Umschalten des Arbeitsmodus
(mit / ohne Schlagzeug)

Verstellbarer Schalter

Richtung
der Drehung
Schalter



**SHARE
20V
Li-ion
technology**

Batterie* 2 Ah - 28080
4 Ah - 28081
8 Ah - 28083

Ladegerät* 2,4 A - 28085
4,0 A - 28086



AKKU-BOHRHAMMER

1.0-300 min⁻¹ / II.0-1000 min⁻¹ | 0-5000 bpm | 1,2J | SDS+ | L R | 1,7 KG

*Batterie und Ladegerät nicht enthalten

Nr. 28025 spezifikation



MAX Ø

Beton - ø 20 mm
Metalle - ø 10 mm
Holz - ø 20 mm



2

**SHARE
20V**

Frequenz Schießen
60-100 min⁻¹

Maximale Länge Nägel / Klammern
30 mm harte Materialien

Maximale Länge Nägel / Klammern
50 mm weiche Materialien

Masse ohne Batterie
2,7 kg

Sicherung

LED-Fehlersignalisierung



ergonomisch gummierte Handgriff für bequemen und sicheren halt

Sicherung Betriebsschalter

Haken zum Aufhängen

Aufnahmemodus-Schalter

Zubehör

SHARE 20V Li-ion technology

Batterie*	2 Ah - 28080	
	4 Ah - 28081	
	8 Ah - 28083	
Ladegerät*	2,4 A - 28085	
	4,0 A - 28086	

- Nägel**
- 23930 Nägel 30 mm, 2000 stck
 - 23931 Nägel 40 mm, 2000 stck
 - 23932 Nägel 50 mm, 2000 stck

- Schnalle**
- 23935 Nagelclip 30 mm, 2000 stck
 - 23936 Nagelclip 40 mm, 2000 stck

Geeignete Arten von Nägeln und Klammern:

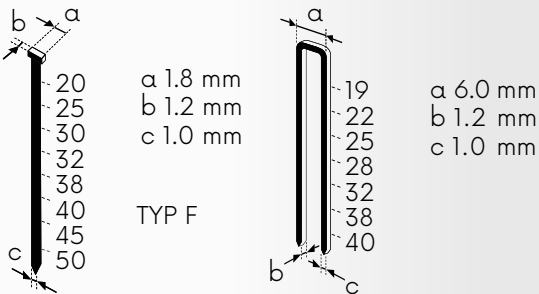

LED-Beleuchtung

leeres Tablett pointer



Sicherung

Regulierung der Schlagkraft



beweglicher Magazindeckel

Verriegelung des Magazindeckels



AKKU-NAGLER UND TACKER

			
---	---	---	---

*Batterie und Ladegerät nicht enthalten

Nr. 28070 spezifikation



BRUSHLESS SHARE 20V

Revolutionieren ohne Last
8500 min⁻¹

Masse ohne Batterie
1,6 kg

Maximale Dicke geschnittenes material
15 mm

Maximal Raddurchmesser
125 mm

Zubehör

SHARE 20V Batterie*
Li-ion technology

2 Ah - 28080
4 Ah - 28081
8 Ah - 28083

Ladegerät*
2,4 A - 28085
4,0 A - 28086



AKKU-WINKELSCHLEIFER



*Batterie, Ladegerät und Disc sind nicht im Lieferumfang enthalten

Nr. 28030 spezifikation

Motorentlüftungen

Ergonomischer gummierter Griff für einen bequemen und sicheren Halt

Dreh Sperre

Schnelles Öffnen Mechanismus
Schutzhülle

Sicherung Betriebschalter



Radspannmuttern



SHARE 20V

Revolutionieren ohne Last
8000 min⁻¹

Masse ohne Batterie
1,6 kg

Maximale Dicke geschnittenes material
15 mm

maximal Raddurchmesser
115 mm

Zubehör

SHARE 20V Batterie*
Li-ion technology

2 Ah - 28080
4 Ah - 28081
8 Ah - 28083

Ladegerät*
2,4 A - 28085
4,0 A - 28086



AKKU-WINKELSCHLEIFER



*Batterie, Ladegerät und Disc sind nicht im Lieferumfang enthalten

Nr. 28032 spezifikation

Ergonomischer gummierter Griff für einen bequemen und sicheren Halt

Dreh Sperre

schnelle Veröffentlichung Mechanismus
Schutzhülle

Sicherung Betriebschalter



Radspannmuttern



**SHARE
20V**

Revolutionieren
ohne Last
10000 min⁻¹

Masse ohne
Batterie
1 kg

Exzentrizität
Räder
5 mm

Durchmesser
Räder
125 mm

Sicherung Betriebsschalter

Staubbeutel

Saugen

Stützscheibe mit Klettverschluss



**SHARE
20V
Li-ion
technology**

Zubehör

Batterie*
2 Ah - 28080
4 Ah - 28081
8 Ah - 28083

Ladegerät*
2,4 A - 28085
4,0 A - 28086



EXZENTERSCHLEIFER



*Batterie und Ladegerät nicht enthalten

Nr. 28040 spezifikation



**SHARE
20V**

Anzahl von
Schwingungen
ohne Last
5000-15000 min⁻¹

Masse ohne
Batterie
1 kg

Revolutionäre
Kontrolle

Werkzeugbefestigungsstift

Ersatzhebel und
Werkzeugverriegelung

Geschwindigkeitskontrolle

ergonomischer gummierter
Griff für einen bequemen
und sicheren Halt



**SHARE
20V
Li-ion
technology**

Zubehör

Batterie*
2 Ah - 28080
4 Ah - 28081
8 Ah - 28083

Ladegerät*
2,4 A - 28085
4,0 A - 28086



AKKU-SCHLEIFER MULTIFUNKTIONAL



*Batterie und Ladegerät nicht enthalten

Nr. 28045 spezifikation



**SHARE
20V**



Geschwindigkeit ohne Last **3650 min⁻¹**

Einstellbar Neigungswinkel des Schnitts **45-90 Grad**

Max. Durchmesser Räder **165 mm** (ø16 mm)

Maximaler Schnitt **50mm**
* in einem Winkel von 90 Grad ø165 mm



Zubehör

SHARE 20V Li-ion technology

Batterie* 2 Ah - 28080
4 Ah - 28081
8 Ah - 28083

Ladegerät* 2,4 A - 28085
4,0 A - 28086



AKKU-HANDKREISSÄGE

- Das Set enthält:
- Kreissäge
 - Seitenführung
 - Schlüssel
 - Sägeblatt ø 165 x 2,8/2,0 x 20 mm 24T (**22314**)



3650min ⁻¹			
ø 165x16mm	L R	2,7	

Nr. 28035 spezifikation



**SHARE
20V**

Anzahl der
Messerhübe

0-2400 min⁻¹

Masse ohne
Batterie
1,8 kg

max. Winkel
Schrägschnitt
45 degrees

max. Schnitt
Profil
Stahl: 6 mm
Holz: 80 mm

Zubehör

**SHARE
20V
Li-ion
technology**

- Batterie* 2 Ah - 28080
- 4 Ah - 28081
- 8 Ah - 28083
- Ladegerät* 2,4 A - 28085
- 4,0 A - 28086



AKKU STICHSÄGE



*Batterie und Ladegerät nicht enthalten

Nr.	spezifikation
28050	

Ergonomischer gummierter Griff für einen bequemen und sicheren Halt

Sicherung
Betriebsschalter

Vorzillation
Einstellung

LED

Schalter
für Sperrfunktion

Stangenverriegelung

Base

Führungsschiene

den Schnitt
abschrägen



**SHARE
20V**

Anzahl von
Schwingungen
ohne Last

0-3000 min⁻¹

Masse ohne
Batterie
1,7 kg

max. Schnittstärke
Holz: 100 mm
Stahl: 5 mm
Aluminium/
Kupfer: 20 mm

Zubehör

**SHARE
20V
Li-ion
technology**

- Batterie* 2 Ah - 28080
- 4 Ah - 28081
- 8 Ah - 28083
- Ladegerät* 2,4 A - 28085
- 4,0 A - 28086



AKKU-RECIPROSÄGE



*Batterie und Ladegerät nicht enthalten

Nr.	spezifikation
28055	

Sicherung
Betriebsschalter

Ergonomischer gummierter Griff für einen bequemen und sicheren Halt

Schnellwechsel
der Sägeblätter

SHARE
20V

max. Druck
8,2 bar

manometer
psi, bar,
kgf/cm², kPa

Schlauch
Ø 10,5 x 600 mm

Stromspannung
20 V

Manometeranzeige mit
Hintergrundbeleuchtung



Ergonomischer
gummierter
Griff für einen
bequemen
und sicheren Halt

Schnellspannfutter zum
Aufpumpen von Reifen

Auto Ladeadapter
3 m

Schlauch
Ø 10,5 x 600 mm



Adapter

Das Set enthält:
- Kompressor
- Auto Ladeadapter
- 3x Aufblasadapter



LED-Licht



Zubehör

SHARE
20V
Li-ion
technology

Batterie*
2 Ah - 28080
4 Ah - 28081
8 Ah - 28083

Ladegerät*
2,4 A - 28085
4,0 A - 28086



LUFTKOMPRESSOR

*Batterie und Ladegerät nicht enthalten

Nr.	spezifikation
28075	
48013	NEWadapter



1
1



NEW
 horizontale Position 110 kg
 vertikale Position 80 kg
 Ø 220 mm
 USB-C



SAUGNAPF AKU

Ø 220 mm	80 kg	110 kg	ROUGH SURFACE	USB-C	Li-ion 3.6V 2Ah
----------	-------	--------	---------------	-------	--------------------

Nr. spezifikation
 36326



SHARE 20V

Saugleistung 60 kg
 Gewicht 3 kg
 Vibration 12 Stufen, 3500 - 8500 r/min
 Stromspannung 20 V

Ergonomischer gummierter Griff für einen bequemen und sicheren Halt



beleuchtetes Display



Saugnapf Ø 125 mm



Zubehör



Batterie*	2 Ah - 28080	
	4 Ah - 28081	
	8 Ah - 28083	
Ladegerät*	2,4 A - 28085	
	4,0 A - 28086	

Das Set enthält:
 - Fliesenrüttler
 - Batterie 2,0 Ah (nur 36328)
 - Ladegerät (nur 36328)
 - Koffer



FLIESEN VIBRATION NIVELLIERMASCHINE

Nr.	spezifikation	
36328	mit 2Ah Akku und Ladegerät	1
36329	ohne Akku und Ladegerät	1



**SHARE
20V**

einstellbarer Vorschub
0-8,7 mm/s

Gewicht
1,7 kg

Drehmoment
6500 N

Stromspannung
20 V

Fassungsvermögen 310 ml



Ergonomischer gummierter Griff für einen bequemen und sicheren Halt

Auslöser mit variabler Geschwindigkeit

LED-Licht



Zubehör

**SHARE
20V
Li-ion
technology**

Batterie*
2 Ah - 28080
4 Ah - 28081
8 Ah - 28083

Ladegerät*
2,4 A - 28085
4,0 A - 28086



AKKU KARTUSCHENPISTOLE

*Batterie und Ladegerät nicht enthalten

Nr.	Spezifikation
28060	



ERSATZ-DICHTMITTEL KARTUSCHE

· 28060

Nr.	Spezifikation
28061	600 ml



600 ml



**SHARE
20V**

Farbtemperatur
5000 K

Masse ohne Batterie
0,9 kg

LED-Leistung
20W

Lichtstrom
2000 lm (100%)

Zubehör

**SHARE
20V
Li-ion
technology**

Batterie*
2 Ah - 28080
4 Ah - 28081
8 Ah - 28083

Ladegerät*
2,4 A - 28085
4,0 A - 28086



Einstellen der Lichtintensität
50%, 100%



LED-BAUSTRAHLER



*Batterie und Ladegerät nicht enthalten

Nr.	spezifikation
28065	



360° Schwenkkopfverstellung



**SHARE
20V**

- tuner
DAB+ / FM / BT
- Leistung
2x 15 W
- Stromspannung
20 V
- Wasserschutz
IP54
- FM Antenne



USB zum Aufladen



Leistung **SHARE
20V**



Farbbildschirm

AUX im
Wagenheber
3,5 mm

**SHARE
20V**
Li-ion
technology

Zubehör

Batterie*

2 Ah - 28080

4 Ah - 28081

8 Ah - 28083



Ladegerät*

2,4 A - 28085

4,0 A - 28086



RADIO AKU DAB+ / FM / BT

- Stereo
- DAB+ / FM
- externer Eingang BluetoothV5.0 / AUX 3,5 mm Klinkenanschluss
- Beständigkeit gegen das Eindringen von Wasser IP54
- 30 voreingestellte Sender (30 for DAB / 30 for FM)
- USB zum Aufladen
- 2.4" Farbbildschirm
- Leistung 2x 15 W
- 20 V / 1,3 A
- 230 V Netzadapter

*Batterie und Ladegerät nicht enthalten

Stereo-Lautsprecher



Stromversorgung - 230V-Adapter



SHARE
20V



LADEGERÄT 20 V | 2,4 A

Nr.	spezifikation
28085	220 – 240 V, 50 – 60 Hz, 70 W



SHARE
20V



LADEGERÄT 20 V | 4,0 A

Nr.	spezifikation
28086	*220 – 240 V, 50 – 60 Hz, 105 W



SHARE *Li-ion technology*
20V



Batterieladeanzeige



BATTERIE 20 V | 2,0 Ah

20V	2,0 Ah	Li-ion	KG 0,4
-----	--------	--------	--------

Nr.	spezifikation
28080	



SHARE *Li-ion technology*
20V



Batterieladeanzeige



BATTERIE 20 V | 4,0 Ah

20V	4,0 Ah	Li-ion	KG 0,7
-----	--------	--------	--------

Nr.	spezifikation
28081	



SHARE *Li-ion technology*
20V



Batterieladeanzeige



BATTERIE 20 V | 8,0 Ah

20V	8,0 Ah	Li-ion	KG 1,0
-----	--------	--------	--------

Nr.	spezifikation
28083	



NEW

SHARE
20V *Li-ion*
technology

28080



28085



ERMÄSSIGT
PREIS

FESTA
POWER X TOOLS

KABELLOSES SET MIT TASCHENSET 2+3

28080 - Akkus für Akkugeräte FESTA SHARE20V 2,0 Ah
28085 - Ladegerät FESTA SHARE20V 2,4 A

Nr.	spezifikation
28090	



SHARE
20V *Li-ion*
technology

28004
Seite 6



28025
Seite 9



37330



28030
Seite 12



BRUSHLESS

ERMÄSSIGT
PREIS
+ KOSTENLOSE
TASCHE

FESTA
POWER X TOOLS

KABELLOSES SET MIT TASCHENSET 3+3

28004 - Akku-Bohrmaschine mit Hammer FESTA SHARE20V
28025 - Akku-Bohrhammer FESTA SDS+ SHARE20V
28030 - Akku-Winkelschleifer FESTA „BRUSHLESS“ SHARE20V 125 mm
28080 - Akkus für Akkugeräte FESTA SHARE20V 2,0 Ah
28081 - Akkus für Akkugeräte FESTA SHARE20V 4,0 Ah
28086 - Ladegerät FESTA SHARE20V 4,0 A

28080
Seite 18



28081
Seite 18



28086
Seite 18



Nr.	spezifikation
28102	



BRUSHLESS **SHARE**
20V *Li-ion*
technology

28002
Seite 5



37330



28030
Seite 12



ERMÄSSIGT
PREIS
+ KOSTENLOSE
TASCHE

FESTA
POWER X TOOLS

KABELLOSES SET MIT TASCHENSET 2+3

28002 - Akku-Bohrmaschine mit Hammer FESTA SHARE20V
28030 - Akku-Winkelschleifer FESTA „BRUSHLESS“ SHARE20V 125 mm
28080 - Akkus für Akkugeräte FESTA SHARE20V 2,0 Ah
28081 - Akkus für Akkugeräte FESTA SHARE20V 4,0 Ah
28086 - Ladegerät FESTA SHARE20V 4,0 A

28080
Seite 18



28081
Seite 18



28086
Seite 18



Nr.	spezifikation
28103	



SHARE
20V *Li-ion*
technology

28004
Seite 6

28032
Seite 12

28055
Seite 15

28035
Seite 14

37330

28040
Seite 13

ERMÄSSIGT
PREIS
+KOSTENLOSE
TASCHE

FESTA
POWER X TOOLS

KABELLOSES SET MIT TASCHENSET 5+3

- 28004 - Akku-Bohrmaschine mit Hammer FESTA SHARE20V
- 28032 - Akku-Winkelschleifer FESTA SHARE20V 115 mm
- 28035 - Handkreissäge Akku FESTA SHARE20V 165 mm/d 16 mm
- 28040 - Exzentrerschleifer Akku FESTA SHARE20V 125 mm 8 otv.
- 28055 - Metallsäge Akku FESTA SHARE20V
- 28080 - Akkus für Akkugeräte FESTA SHARE20V 2,0 Ah
- 28081 - Akkus für Akkugeräte FESTA SHARE20V 4,0 Ah
- 28086 - Ladegerät FESTA SHARE20V 4,0 A



28080
Seite 18



28081
Seite 18



28086
Seite 18



Nr. spezifikation

28101



1

SHARE
20V *Li-ion*
technology

BRUSHLESS

28002
Seite 5

28030
Seite 12

28040
Seite 13

BRUSHLESS

28055
Seite 15

37330

28035
Seite 14

ERMÄSSIGT
PREIS
+KOSTENLOSE
TASCHE

FESTA
POWER X TOOLS

KABELLOSES SET MIT TASCHENSET 5+3

- 28002 - Akku-Bohrmaschine mit Hammer FESTA SHARE20V
- 28030 - Akku-Winkelschleifer FESTA „BRUSHLESS“ SHARE20V 125 mm
- 28035 - Handkreissäge Akku FESTA SHARE20V 165 mm/d 16 mm
- 28040 - Exzentrerschleifer Akku FESTA SHARE20V 125 mm 8 otv.
- 28055 - Metallsäge Akku FESTA SHARE20V
- 28080 - Akkus für Akkugeräte FESTA SHARE20V 2,0 Ah
- 28081 - Akkus für Akkugeräte FESTA SHARE20V 4,0 Ah
- 28086 - Ladegerät FESTA SHARE20V 4,0 A

28080
Seite 18



28081
Seite 18



28086
Seite 18



Nr. spezifikation

















28104



1

BRUSHLESS

Das Werkzeug wird von einem bürstenlosen Gleichstrommotor angetrieben

Drehmoment	
Geschwindigkeit	
wählbare Richtung der Drehung	
Futter	
Bohren, Schlagbohren, Schrauben	
Schlagzahl pro Minute	
Bohren, Schrauben	
Masse mit/ohne Akku	
Methode der Befestigung	
Methode der Befestigung	
Methode der Befestigung	
Scheibenexzentrizität	
Bedienung des Gerätes für rechte und linke Hand	
erfüllt diesen Standard	
Lichtstrom	
Richtungswinkel des Lichts	
maximale Zündfrequenz	

**SHARE
20V**

Das Tool ist kompatibel mit beiden Akkus

	geeignete Nagelarten
	geeignete Schnallenarten
	Schleifrad mit Löchern
	maximaler Raddurchmesser
	Raddurchmesser
	maximale Schnittstärke Material: Holz
	maximale Schnittstärke Material: Stahl
	Voroszillationseinstellung
	Sägeaufsatz
	Anzahl der Messerhübe
	Möglichkeit der Abschrägung Schnitt
	Schnellspanner des Sägeblattes
	Anzahl Sägeschwingungen
	LED-Beleuchtung
	Batteriekapazität
	Batterie
	Ladezeit Batterie

NEW

stufenlose
Drehzahlregelung
520 min⁻¹

BPM / Wirkung
0 - 4100 / 12 J

Leistung
1500 W

Spannsystem
SDS MAX



MAX ø Beton - ø 40 mm



Tiefenmesser

Schwingungsreduktion
System

Ergonomischer
gummierter
Griff für einen
bequemen
und sicheren Halt



Staubdichte Abdeckung

SDS MAX
Aufnahme



Zusätzlicher Handgriff



3.0m

FESTA
POWER X TOOLS

**SCHLAGBOHRER
SDS MAX**

Das Set enthält:

- Schlagbohrer
- seitlicher Griff
- Tiefenmesser
- Staubdichte Abdeckung
- Schlüssel
- Plastikbehälter
- Ersatzkohlebürsten
- Zubehör SDS MAX:

ø 16 x 280 mm
| 18 x 320 mm

Ersatzkohlenstoffe
2 Stk

- 28229



230V ~ 50Hz	1500W	4100 bpm	520min ⁻¹	12J	SDS MAX	3m RUBBER	6.8 kg	MAX ø40mm Concrete	
----------------	-------	-------------	----------------------	-----	------------	--------------	-----------	-----------------------	--

Nr. 28221
spezifikation

FESTA
POWER X TOOLS

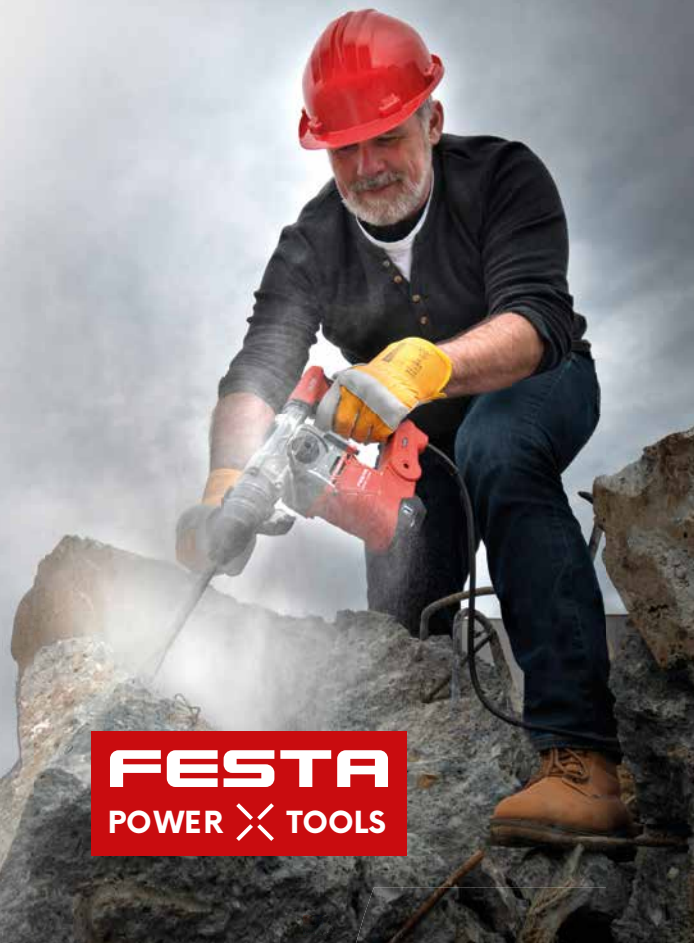

stufenlose
Drehzahlregelung
0 - 850 min⁻¹

BPM / Wirkung
0 - 4500 / 6 J

Leistung
1500 W

Spannsystem
SDS+



MAX Ø
Beton - ø 32 mm
Metalle - ø 13 mm
Holz - ø 40 mm



Tiefenmesser

Schwingungsreduktion
System

Ergonomischer
gummierter
Griff für einen
bequemen
und sicheren Halt

SDS+
Aufnahme

Zusätzlicher Handgriff



2.0m

FESTA
POWER X TOOLS

SCHLAGBOHRER

- Das Set enthält:
- Schlagbohrer
 - seitlicher Griff
 - Tiefenmesser
 - Schlüssel
 - Plastikbehälter
 - Ersatzkohlebürsten
 - Zubehör SDS+:

- ⚡ ø 8, 10, 12 x 160 mm
- 🔧 20 x 250 mm
- 🔧 14 x 250 mm



230V ~ 50Hz	1500W	0-4500 bpm	0-850 min ⁻¹	6J	SDS+	2m RUBBER	5.0 KG
----------------	-------	---------------	----------------------------	----	------	--------------	-----------

Ersatzkohlenstoffe
2 Stk

- 28228



stufenlose
Drehzahlregelung
0 - 1350 min⁻¹

BPM / Wirkung
0 - 5500 / 2,8 J

Leistung
800 W

Spannsystem
SDS+
ø 2 - 13 mm



MAX ø Beton - ø 26 mm
Metalle - ø 13 mm
Holz - ø 30 mm

SDS+ Aufnahme

Schnellspannfutter

Umschaltung
Drehrichtung

Tiefenmesser



Ergonomischer
gummierter
Griff für einen
bequemen
und sicheren Halt

seitlicher Griff

2.0m

SDS+

ø 2 - 13 mm

FESTA
POWER X TOOLS

SCHLAGBOHRER

Das Set enthält:

- Schlagbohrer
- seitlicher Griff
- Tiefenmesser
- Futter ø 2 - 13 mm
- Plastikbehälter
- Vaseline
- Ersatzkohlebürsten
- Zubehör SDS+:

ø 6, 8, 10 x 160 mm

20 x 250 mm

14 x 250 mm

230V
~ 50Hz

800W



0-1350min⁻¹

2.8J

SDS+

2m
RUBBER

3.2

Ersatzkohlenstoffe
2 Stk - 28223



Nr. spezifikation

28220

stufenlose
Drehzahlregelung
0 - 4500 min⁻¹

Gewicht
4,3 kg

Leistung
1400 W

max.
Sägeblatt

Durchmesser / Aufnahme
max ø 185 mm / ø 20 mm



max. 63 mm



max. 45°



Ergonomischer
gummierter
Griff für einen
bequemen
und sicheren Halt



Spanabsaugungø
35 mm

2.0m

Längsschnittanschlag
(Seitenführung)
6 - 120 mm



22316

FESTA
POWER X TOOLS

KREISSÄGE

- Das Set enthält:
- Kreissäge
 - Seitenführung
 - Schlüssel
 - Ersatzkohlebürsten
 - Sägeblatt ø 185 x 2,3/1,3 x 20 mm 24T (22316)

1400W	230V ~ 50Hz	4500 min⁻¹	ø 20 1 mm MAX 185mm	90° 63mm	45° 42mm	KG 4.3
--------------	-----------------------	------------------------------	---------------------------	-------------	-------------	-------------------------

Ersatzkohlenstoffe
2 Stk - 28233



Nr. spezifikation
28230

Drehzahl
6600 min⁻¹

Gewicht
5,8 kg

Leistung
2400 W

Aufnahme
M14
max ø 230 mm



Ergonomischer gummierter Griff für einen bequemen und sicheren Halt

SOFT START

sanfter Motorstart



Schutzvorrichtung



FESTA
POWER X TOOLS

WINKELSCHLEIFER

- Das Set enthält:
- Winkelschleifer
 - Schutzvorrichtung
 - seitlicher Griff
 - Schlüssel
 - Ersatzkohlebürsten

2400W	230V ~ 50Hz	6600 min⁻¹ SOFT START	M14	max ø 230mm	2.0m RUBBER	5.8 KG	
--------------	-----------------------	--	------------	--------------------	-----------------------	------------------	--

Ersatzkohlenstoffe - 28218
2 Stk



Nr. 28215 spezifikation

Drehzahl
11000 min⁻¹

Gewicht
2 kg

Leistung
900 W

Werkzeugaufnahme
M14
max ø 125 mm

seitlicher Griff



SOFT START
sanfter Motorstart

Schutzschalter



3,0m

Schutzvorrichtung

FESTA
POWER X TOOLS

WINKELSCHLEIFER

- Das Set enthält:
- Winkelschleifer
 - Schutzvorrichtung
 - seitlicher Griff
 - Schlüssel
 - Ersatzkohlebürsten



900W	230V ~ 50Hz	11000min⁻¹	M14	max ø 125mm	2.0m RUBBER	KG 2.0		Ersatzkohlenstoffe - 28213	
-------------	-----------------------	------------------------------	------------	--------------------	-----------------------	-------------------------	--	-----------------------------------	--

Nr. 28210 spezifikation

8

FESTA
POWER X TOOLS

ERSATZKOHLEBÜRSTEN

2x



Nr.	spezifikations	
28229	für 28221	1
28228	für 28225	1
28223	für 28220	1
28233	für 28230	1
28213	für 28210	1
28218	für 28215	1



SDS-ADAPTER MAX FÜR SDS +

SDS MAX → SDS+		
Nr.	Spezifikation	
20744		1



SDS + ADAPTER

SDS+		
Nr.	Spezifikation	
20745		1



FESTA

ADAPTER SDS + BIT 1/4"

SDS+ → 1/4"		
Nr.	Spezifikation	
20743	75 mm	20



FESTA

SPANNFUTTER

1/2"		
Nr.	Spezifikation	
20960	1-13 mm + 2 klíče, 1/2 - 20 UNF	3
20966	náhradní klíček	25



FESTA

SCHNELLSPANNFUTTER

1/2"		
Nr.	Spezifikation	
20965	1,5 - 13 mm 1/2' - 20 UNF	1



SCHNELLSPANNFUTTER

1/2"		
Nr.	Spezifikation	
20961	1,5 - 13 mm 1/2' - 20 UNF	1



BOHRAUFSATZ 90°

Nr.	Spezifikation	
20365	Ø 1 - 10 mm	10



SCHNELLSPANNFUTTER FÜR AKKU

1/4"		
Nr.	Spezifikation	
20963	Ø 1 - 6 mm	10



max Ø 70 mm



FESTA

STAUBABSAUGER

Nr.	Spezifikation	
28267	max. 70 mm	1

FÜHRUNG FÜR BOHRER UND BOHRKRONEN

Nr.	Spezifikation	
20379	Ø 4, 5, 6, 7, 8, 10, 12 mm	10

TECHNISCH SPEZIFIKATIONEN



PRODUKT KATALOG NUMMER	28000	28001	28002	28003	28004
Name	Akkubohrer mit Hammer	Akkubohrer mit Hammer	Akkubohrer mit Hammer	Akkubohrer mit Hammer	Akkubohrer mit Hammer
Revolutionieren ohne Last	I.0-550 min ⁻¹ II.0-2000 min ⁻¹	I.0-550 min ⁻¹ II.0-2000 min ⁻¹	I.0-550 min ⁻¹ II.0-2000 min ⁻¹	I.0-500 min ⁻¹ II.0-1800 min ⁻¹	I.0-500 min ⁻¹ II.0-1800 min ⁻¹
Anzahl der Treffer	I.0-8800min ⁻¹ II.0-32000min ⁻¹	I.0-8800min ⁻¹ II.0-32000min ⁻¹	I.0-8800min ⁻¹ II.0-32000min ⁻¹	0-19200 min ⁻¹	0-19200 min ⁻¹
Anzahl der Schläge					
Drehmoment	80 Nm	80 Nm	80 Nm	45 Nm	45 Nm
Max. Batteriespannung	20V	20V	20V	20V	20V
Anzahl der Drehmomentstufen	20+1+1	20+1+1	20+1+1	19+1+1	19+1+1
Spannkopf	2-13 mm	2-13 mm	2-13 mm	2-13 mm	2-13 mm
Gewicht ohne Batterie	1,4kg	1,4kg	1,4kg	1,3kg	1,3kg
Abdeckung	IPX0	IPX0	IPX0	IPX0	IPX0
Schalldruckpegel Ungewissheit K	LpA=97,04dB(A) K=5dB(A)	LpA=97,04dB(A) K=5dB(A)	LpA=97,04dB(A) K=5dB(A)	LpA=79dB(A) K=5dB(A)	LpA=79dB(A) K=5dB(A)
Schallleistungspegel Ungewissheit K	LwA=86,04dB(A) K=5dB(A)	LwA=86,04dB(A) K=5dB(A)	LwA=86,04dB(A) K=5dB(A)	LwA=90dB(A) K=5dB(A)	LwA=90dB(A) K=5dB(A)
Vibration ohne Hämmern ins Metall	$\alpha_{h,D}=3,9m/s^2$ K=1,5m/s ²	$\alpha_{h,D}=3,9m/s^2$ K=1,5m/s ²	$\alpha_{h,D}=3,9m/s^2$ K=1,5m/s ²	$\alpha_{h,D}=2,4m/s^2$ K=1,5m/s ²	$\alpha_{h,D}=2,4m/s^2$ K=1,5m/s ²
Vibration ohne Hämmern in Beton	$\alpha_{h,ID}=11,4m/s^2$ K=1,5m/s ²	$\alpha_{h,ID}=11,4m/s^2$ K=1,5m/s ²	$\alpha_{h,ID}=11,4m/s^2$ K=1,5m/s ²	$\alpha_{h,ID}=7,5m/s^2$ K=1,5m/s ²	$\alpha_{h,ID}=7,5m/s^2$ K=1,5m/s ²
Maximale Schwingung, Unsicherheit K					
Kampfruppe					
Bohrdurchmesser					
Vibration in den Beton -HauptHandgriff					
Schwingungen im Beton - Zusätzlicher Handgriff					
Packungsinhalt	bohren, 2.4 A Ladegerät, Batterie 2.0 Ah, 4.0 Ah Batterie, Zusätzlicher Handgriff, Koffer	bohren, Ladegerät 2.4 A, Batterie 2.0 Ah, Zusätzlicher Handgriff, Koffer	bohren	bohren, 2.4 A Ladegerät, 2x 2.0 Ah Batterien, 6x bit, Träger, 6x bohren, Koffer	bohren



28005	28006	28007	28008	28021	28025
Akkuschrauber bohren	Akkuschrauber bohren	Akkuschrauber bohren	Akkuschrauber	Akku-Bohrschrauber	Akku-Bohrhammer
I.0-350 min ⁻¹ II.0-1300 min ⁻¹	I.0-350 min ⁻¹ II.0-1300 min ⁻¹	I.0-350 min ⁻¹ II.0-1300 min ⁻¹	200 min ⁻¹	0-2000 min ⁻¹	I.0-300 min ⁻¹ II.0-1000 min ⁻¹
					0-5000bpm
				0-3000bpm	
28 Nm	28 Nm	20 Nm	3 Nm	150 Nm	
20V	20V	12V	3.6V	20V	20V
19+1	19+1	19+1	6+1		
1-10mm	1-10mm	1-10mm	1/4" hexagon	1/4" hexagon	SDS+
0,9kg	0,9kg	*1kg	*0,4kg	1,2kg	1,7kg
IPX0	IPX0	IPX0	IPX0	IPX0	IPX0
LpA=69dB(A) K=5dB(A)	LpA=69dB(A) K=5dB(A)	LpA=78dB(A) K=5dB(A)	LpA=58dB(A) K=3dB(A)	LpA=92dB(A) K=3dB(A)	LpA=82,98dB(A) K=3dB(A)
LwA=80dB(A) K=5dB(A)	LwA=80dB(A) K=5dB(A)	LwA=67dB(A) K=5dB(A)	LwA=69dB(A) K=3dB(A)	LwA=103dB(A) K=3dB(A)	LwA=93,98dB(A) K=3dB(A)
$\alpha_{h,D} < 1,9m/s^2$ K=1,5m/s ²	$\alpha_{h,D} < 1,9m/s^2$ K=1,5m/s ²	$\alpha_{h,D} = 2,1m/s^2$ K=1,5m/s ²			
$\alpha_{h,D} = 10,1m/s^2$ K=1,5m/s ²	$\alpha_{h,D} = 10,1m/s^2$ K=1,5m/s ²	$\alpha_{h,D} = 7,5m/s^2$ K=1,5m/s ²			
			$\alpha_h < 2,5m/s^2$ K=1,5m/s ²	$\alpha_{h,D} = 15,9m/s^2$ K=1,5m/s ²	
					1,2J
					stahl: 10mm concrete: 20mm holz: 20mm
					$\alpha_{h,(HD)} = 5,582m/s^2$ K=1,5m/s ²
					$\alpha_{h,(HD)} = 5,523m/s^2$ K=1,5m/s ²
bohren, 2.4 A Ladegerät, 2x 2.0 Ah Batterien, 6x bit, Träger, 6x bohren, Koffer	bohren	bohren, 2.4 A Ladegerät, 2x 1.5 Ah Batterien, 6x bits, Träger, 6x bohren, Koffer	screwdriver, Ladegerät 0.5 A, 1.5 Ah Batterie, 5x bit	tightener	Bohrhammer, Zusätzlicher Handgriff, Tiefenanschlag

* Gewicht ist inklusive Batterie angegeben

TECHNISCH SPEZIFIKATIONEN



PRODUKT KATALOG NUMMER	28030	28032	28035	28040
Name	Akku-Winkelschleifer	Akku-Winkelschleifer	Akku-Handkreissäge	Exzentrerschleifer
No-Load-Revolutionieren	8500 min ⁻¹	8000 min ⁻¹	3650 min ⁻¹	10000 min ⁻¹
Anzahl der Schwingungen ohne Last				
Nach vorne				
Anzahl der Vorschwinggrade				
Anzahl der Blätter des Sägeblattes				
Maximales Schnittprofil				
Maximaler Raddurchmesser	125 mm	115 mm		
Stützscheibe				125 mm
8 Sauglöcher auf dem Kreis				65 mm
Exzentrizität des Rades				5 mm
Größe des Spindelgewindes	M14	M14		
Maximale Dicke des geschnittenen Materials	15 mm	15 mm		
max. Batteriespannung	20V	20V	20V	20V
Einstellbarer Schnittwinkel			0-45°	
In einem Winkel von 45 ° schneiden			35 mm	
In einem Winkel von 90 ° schneiden			50 mm	
Oszillationswinkel				
Abmessung der Delta-Schleifbasis				
Vibration Revolutionieren Kontrolle				
Anbringen des Sägeblattes				
Hub des Sägeblattes				
Größe Grundplatte			28 cm x 13,3 cm	
Gewicht ohne Batterie	1,6kg	1,6kg	2,7kg	1kg
Raddurchmesser			165 mm	
Dicke des Radkörpers			1,4 mm ± 5% mm	
Dicke SK der Messerklinge			2,0 ± 5% mm	
Schnittbreite			2,3 ± 5% mm	
Durchmesser der Radbohrung nach dem Spannen			16 mm	
Anzahl der Scheibenzähne			24	
Abdeckung	IPX0	IPX0	IPX0	IPX0
Art Nägel, Höhe x Breite x Dicke				
Schnallen-Spanne x Höhe x Breite x Dicke				
max. Länge der Nägel / Clips in weiche Matten.				
max. Länge der Nägel / Clips in Hartmatt.				
Durchschnitt / max. Schussfrequenz				
Betriebszeit (4 AH Akku, voll aufgeladen)				
Nail / staple magazine capacity				
Schalldruckpegel Ungewissheit K	LpA=87,1dB(A) K=3dB(A)	LpA=76,67dB(A) K=3dB(A)	LpA=84dB(A) K=3dB(A)	LpA=76dB(A) K=3dB(A)
Schalleistungspegel Ungewissheit K	LwA=98,1dB(A) K=3dB(A)	LwA=87,67dB(A) K=3dB(A)	LwA=95dB(A) K=3dB(A)	LwA=87dB(A) K=3dB(A)
Vibration when grinding the surface	$\alpha_{h,AG}=8,363m/s^2$ K=1,5m/s ²	$\alpha_{h,AG}=5,324m/s^2$ K=1,5m/s ²		
Vibration for cutting the board				
Vibration for sheet metal cutting				
Vibration for cutting Holzen frames				
Maximale Schwingung, Unsicherheit K			$\alpha_h < 2,5m/s^2$ K=1,5m/s ²	$\alpha_h = 9,5m/s^2$ K=1,5m/s ²
Packungsinhalt	Schleifer, Radabdeckung, Zusätzlicher Handgriff, Schraubenschlüssel	Schleifer, Radabdeckung, Zusätzlicher Handgriff, Schraubenschlüssel	sah, Tiefenanschlag, Sägeblatt	Schleifer, Staubbeutel



28045	28050	28055	28070
Akku-Schleifer multifunktional	Akku Stichsäge	Akku-Reciprosäge	Akku-Nagler und Tacker
5000-15000 min ⁻¹		0-3000 min ⁻¹	
		1°	
	3+0		
	0-2400 min ⁻¹		
	Stahl: 6mm, Holz: 80mm	Holz: 100 mm, Stahl: 5 mm, Aluminium / Kupfer: 20 mm	
20V		20V	20V
	Schrägschnitt max. 45 °		
3°			
90 mm			
JA			
universal		universal	
		20 mm	
1kg	1,8kg	1,7kg	2,7kg
IPX0	IPX0	IPX0	IPX0
			F, 20-50mm x 1,2mm x 1,0 mm
			6,0mm x 19-40mm x 1,2mm x 1,0mm
			50 mm
			30 mm
			60/100 min ⁻¹
			1 Stunde
			100 Stücke
LpA=78dB(A) K=3dB(A)	LpA=88,1dB(A) K=5dB(A)	LpA=87,33dB(A) K=5dB(A)	LpA=79,9dB(A) K=3dB(A)
LwA=89dB(A) K=3dB(A)	LwA=99,1dB(A) K=5dB(A)	LwA=98,33dB(A) K=5dB(A)	LwA=90,9dB(A) K=3dB(A)
	$\alpha_{h,B}=3,3m/s^2$ $K=1,5m/s^2$ $\alpha_{h,M}=4m/s^2$ $K=1,5m/s^2$	$\alpha_{h,B}=21,10m/s^2$ $K=1,5m/s^2$	
		$\alpha_{h,WB}=21,98m/s^2$ $K=1,5m/s^2$	
$\alpha_h=2,8m/s^2$ $K=1,5m/s^2$			$\alpha_h=1,39m/s^2$ $K=1,5m/s^2$
Mühle, Zubehör (Säge, Schaber, Träger), 3x Schleifpapier P80	Säge, Führungsschiene, Saugaufsatz, 2x Sägeblatt	Säge, 2x Sägeblatt	Nagler / Tacker, 200x Nägel, 200x Klammern

TECHNISCH SPEZIFIKATIONEN



PRODUKT KATALOG NUMMER	28075	36328	36329	28060	28076
Name	Luftkompressor	Fliesenvibration Nivelliermaschine	Fliesenvibration Nivelliermaschine	Akku Kartuschenpistole	Radio AKU DAB+ / FM / BT
manometer	psi; bar; kgf/cm ² ; kPa				
max. Druck	120 psi / 8,2 bar				
Schlauch	Ø 10,5 x 600 mm				
Saugnapf		Ø 123 mm	Ø 123 mm		
Saugleistung		60 kg	60 kg		
Vibration		12 Stufen 3500 - 8500 r/min	12 Stufen 3500 - 8500 r/min		
Drehmoment				6500 N	
einstellbarer Vorschub				0 - 8,7 mm/s	
Fassungsvermögen				310 ml	
Tuner					DAB+ / FM
Externer Eingang					Bluetooth 5.0, AUX 3,5 mm Klinkenanschluss
Leistung					2 x 15 W
Display					2,4" Farbbildschirm
Stromversorgung					adapter 230 V, Batterie Li-ion FESTA share 20 V
Voreingestellte Sender					30 (DAB+), 30 (FM)
Wasserschutz					IPX54
Gewicht		3 kg	3 kg	1,7 kg	1,3kg
Stromspannung	20 V	20 V	20 V	20 V	20 V
Das Set enthält	Kompressor, Auto Ladeadapter, 3x Aufblasadapter	Fliesenrüttler, Batterie 2,0 Ah, Ladegerät, Koffer	Fliesenrüttler, Koffer	Kartuschenpistole	Radio, Adapter 230 V



PRODUKT KATALOG NUMMER	28221	28225	28220	28230	28210	28215
Name	Schlagbohrer SDS MAX	Schlagbohrer SDS+	Schlagbohrer	Kreissäge	Winkelschleifer	Winkelschleifer
Leistung	1 500 W	1 500 W	800 W	1 400 W	900 W	2 400 W
Leerlaufgeschwindigkeit	0 - 520 min-1	0 - 850 min-1	0 - 1 350 min-1	0 - 4 500 min-1	0 - 11 000 min-1	0 - 6 600 min-1
Anzahl der Treffer	0 - 4 100	0 - 4 500	0 - 5 500			
Kampftruppe	12 J	6 J	2,8 J			
Spannkopf/Schaft	SDS MAX	SDS+	SDS+ Aufnahme 2 - 13 mm	20 mm	M14 / 22,2 mm	M14 / 22,2 mm
Einstellbarer Schnittwinkel				0 - 45°		
Im 45°-Winkel schneiden				42 mm		
Im 90°-Winkel schneiden				63 mm		
Maximaler Raddurchmesser				185 mm	125 mm	230 mm
Gewicht	6,8 kg	5 kg	3,2 kg	4,3 kg	2 kg	5,8 kg
Länge des Netzkabels material	3 m Gummi	2 m Gummi	2 m Gummi	2 m Plastik	2 m Gummi	2 m Gummi
Packungsinhalt	Schlagbohrer, seitlicher Griff, Tiefenmesser, Schlüssel, Plastikbehälter, Ersatzkohlebürsten, Zubehör SDS MAX: ⚡ ∅ 16 x 280 mm 18 x 320 mm	Schlagbohrer, seitlicher Griff, Tiefenmesser, Schlüssel, Plastikbehälter, Ersatzkohlebürsten, Zubehör SDS+: ⚡ ∅ 8, 10, 12 x 160 mm ▼ 20 x 250 mm 14 x 250 mm	Schlagbohrer seitlicher Griff Tiefenmesser Futter ∅ 2 - 13 mm Plastikbehälter Vaseline Ersatzkohlebürsten Zubehör SDS+: ⚡ ∅ 6, 8, 10 x 160 mm ▼ 20 x 250 mm 14 x 250 mm	Kreissäge, Seitenführung, Schlüssel, Ersatzkohlebürsten, Sägeblatt, ∅ 185 x 2,3 / 1,3 x 20 mm 24T	Winkelschleifer, Schutzvorrichtung, seitlicher Griff, Schlüssel, Ersatzkohlebürsten	Winkelschleifer, Schutzvorrichtung, seitlicher Griff, Schlüssel, Ersatzkohlebürsten

NEW

Drehzahl
1000 - 1850 min⁻¹

Länge
110 - 180 cm

Leistung
750 W

Werkzeug-
aufnahme
Ø 225 mm



Ergonomischer
gummierter Griff für
einen bequemen
und sicheren Halt



TROCKENBAUSCHLEIFER

230V ~ 50Hz	750W	1000-1850min ⁻¹	Ø 225mm	110-180 cm
LED	4m	DRYWALL		



Nr. 28240 spezifikation

1

NEW



FESTA
POWER X TOOLS

STAUBSAUGER 30L

230 V ~50 Hz | 1600 W | MAX 2000W | 82dB | IPX4 | 3m | 5m

30L | WET DRY | AUTO ON-OFF | AUTOMATIC FILTER CLEANING | HEPA

Nr.	spezifikation	
28345		1
28346	HEPA-Filter	1

NEW



WEST BERG

STAUBSAUGER 30L

230 V ~50 Hz | 1200 W | 3m | 5m | SEMI-AUTOMATIC FILTER CLEANING

30L | WET DRY | AUTO ON-OFF | SEMI-AUTOMATIC FILTER CLEANING

Nr.	spezifikation	
28340		1
28342	HEPA-Filter	1

FESTA
 POWER X TOOLS

**ELEKTRISCHES RÜHRWERK
 FÜR BAUSTOFFE ZWEI QUIRLLEN**

Anschlussleistung	1800 W
Spannung/Frequenz	230 V / 50 Hz
Geschwindigkeitsstufen	2
1. Gang (Leerlaufdrehzahl)	0 - 450 ot./min.
2. Gang (Leerlaufdrehzahl)	0 - 790 ot./min.
Überlastungsschutz	Ja
Durchmesser des Rührkorbs	100 mm
Rührerlänge	570 mm
Gewicht	5,6 kg

Zn **CE**

Nr.	spezifikation	
35311	Rührwerk	1
35318	Ersatzkohle	1
35319	Ersatzrührer - Paar (L+R)	1

FESTA
 POWER X TOOLS

ELEKTRISCHES MISCHWERK FÜR BAUSTOFFE 1600 W

Anschlussleistung	1600 W
Spannung/Frequenz	230 V / 50 Hz
Geschwindigkeitsstufen	2
1. Gang (Leerlaufdrehzahl)	0 - 480 ot./min.
2. Gang (Leerlaufdrehzahl)	0 - 800 ot./min.
Überlastungsschutz	Ja
Rührergewinde	M 14
Durchmesser des Rührkorbs	140 mm
Rührerlänge	600 mm
Gewicht	4,7 kg

M14 **Zn** **CE**

Nr.	spezifikation	
35310		1
35317	Ersatzkohle	1

FESTA
 POWER X TOOLS

ELEKTRISCHES MISCHWERK FÜR BAUSTOFFE 850 W

Anschlussleistung	850 W
Spannung/Frequenz	230 V / 50 Hz
Geschwindigkeitsstufen	1
1. Gang (Leerlaufdrehzahl)	0 - 500 ot./min.
2. Gang (Leerlaufdrehzahl)	-
Überlastungsschutz	Ja
Rührergewinde	M 14
Durchmesser des Rührkorbs	120 mm
Rührerlänge	600 mm
Gewicht	3,7 kg

M14 **Zn** **CE**

Nr.	spezifikation	
35300		1
35316	Ersatzkohle	1



NEW

WEST BERG

ELEKTRISCHES MISCHWERK FÜR BAUSTOFFE 1600 W

Anschlussleistung	1600 W
Spannung/Frequenz	230 V / 50 Hz
Geschwindigkeitsstufen	2
1. Gang (Leerlaufdrehzahl)	180 - 400 ot./min.
2. Gang (Leerlaufdrehzahl)	300 - 700 ot./min.
Überlastungsschutz	Ja
Rührergewinde	M 14
Durchmesser des Rührkorbs	140 mm
Rührerlänge	600 mm
Gewicht	5,4 kg

M14	Zn	CE	
Nr.	spezifikation		
35305			1
35315	Ersatzkohle		1



NEW



FESTA
POWER X TOOLS

HOCHDRUCK-REINIGER

230 V ~50 Hz	1800 W	IPX5	MAX 7 l/min	MAX 140 bar	MAX 50°C	5m	AUTO STOP	7,8 kg
------------------------	---------------	-------------	--------------------	--------------------	-----------------	-----------	------------------	---------------

Nr.	Spezifikation	
45271		1



FESTA

HOCHDRUCK-REINIGER

230 V ~50 Hz	1500 W	MAX 120 bar	MAX 6 l/min	IPX5	5m	AUTO STOP
------------------------	---------------	--------------------	--------------------	-------------	-----------	------------------

Nr.	Spezifikation	
45270	Hochdruckreiniger	1

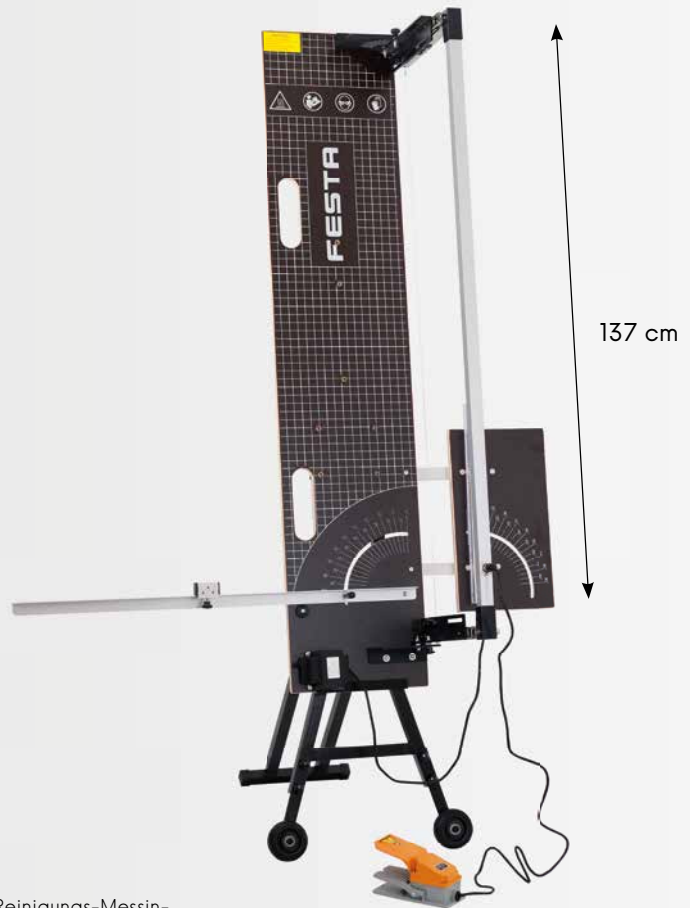
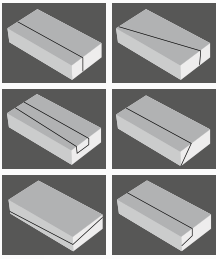

STYROPORDRAHTSCHNEIDER

- Spannung/Frequenz: 230 V/50 Hz
- Leistungsaufnahme: 200 W
- Schnittlänge: 137 cm
- Schnitthöhe: 35 cm
- Schutzart: IP44
- Schnittwinkel: 0° - 90°

· Ausstattung: Ständer, Fußschalter, Gerüsthalter, 2x Ni-Cr-Schneiddraht, Reinigungs-Messingbürste, Werkzeug und Befestigungsmaterial, Kunststoffbox mit Rädern



Nr. Spezifikation

35348



1

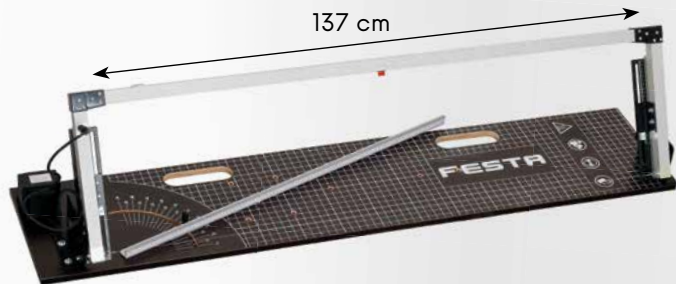
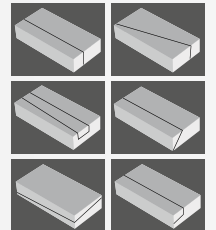
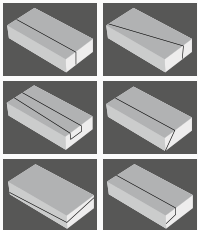

STYROPORDRAHTSCHNEIDER

- Spannung/Frequenz: 230 V / 50 Hz
- Leistungsaufnahme: 200 W
- Schnittlänge: 137 cm
- Schnitthöhe: 35 cm
- Schutzart: IP44
- Schnittwinkel: 0° - 90°



Nr. Spezifikation

35345



1



STYROPORDRAHTSCHNEIDER

- Spannung/Frequenz: 230 V / 50 Hz
- Leistungsaufnahme: 160 W
- Schnittlänge: 117 cm
- Schnitthöhe: 35 cm
- Schutzart: IP44
- Schnittwinkel: 0° - 90°



Nr. Spezifikation

35330



1



FESTA

STYROPORDRAHTSCHNEIDER

- Spannung/Frequenz: 230 V / 50 Hz
- Leistungsaufnahme: 160 W
- Schnittlänge: 117 cm
- Schnitthöhe: 52 cm
- Schutzart: IP44
- Schnittwinkel: 0° - 90°



· Ausstattung: Ni-Cr-Schneidedraht, Reinigungsbürste aus Messing, Inbus

Nr.	Spezifikation	
35344		1



FESTA

FUSSSCHALTER FÜR STYROPORSCHNEIDER

· für 35330, 35345, 35348



Nr.	Spezifikation	
35334		1



FESTA

STAND FÜR STYROPORSCHNEIDER

· für 35330, 35345, 35348



Nr.	Spezifikation	
35336		1



FESTA

ERSATZFEDER FÜR STYROPORSCHNEIDER

· für 35330, 35345, 35348



Nr.	Spezifikation	
35332		1



FESTA

ERSATZ TRAFO FÜR STYROPORSCHNEIDER

· für 35330, 35345, 35348



- | | |
|--------------------|--------------|
| Spannung/Frequenz: | 230 V / 50Hz |
| Ausgabe: | 36 V / 5 A |
| Leistungsaufnahme: | 200 W |



Nr.	Spezifikation	
35347		1



FESTA

GERÜSTHALTER FÜR STYROPORSCHNEIDER

· für 35330, 35345, 35348



Nr.	Spezifikation	
35333		1



ERSATZ-SCHNEIDEDRAHT Cr-Ni FÜR STYROPORSCHNEIDER



Nr.	Spezifikation	
35331	für Styroporschneider 117 cm	1
35346	für Styroporschneider 137 cm	1



Li-ion
technology

FESTA
POWER X TOOLS

KABELLOSER STYROPORSCHNEIDER

- Akku: 36 V, 1,5Ah Li-ion
- Leistung: 180 W
- Temperatur: max 350 C°
- Klingenlänge: 20 cm
- Ausstattung: 2 Akkus, Ladegerät, Klinge, Messing-Reinigungsbürste, Inbus



Nr.	Spezifikation	
35323	Elektrischer Styroporschneider	1
35328	Ersatzklinge für Styroporschneider 14 cm	1
35329	Ersatzklinge für Styroporschneider 25 cm	1



FESTA
POWER X TOOLS

ELEKTRISCHER STYROPORSCHNEIDER

- Spannung / Frequenz: 230 V/50 Hz
- Leistungsaufnahme: 250 W
- Temperatur: 50-600 C°
- Klingenlänge: 25 cm
- Netzleitungslänge: 3 m



· Ausrüstung: Reinigungsbürste aus Messing, Inbus, Messer 25 cm, Koffer

Nr.	Spezifikation	
35326	Elektrischer Styroporschneider	1
35328	Ersatzklinge für Styroporschneider 14 cm	1
35329	Ersatzklinge für Styroporschneider 25 cm	1

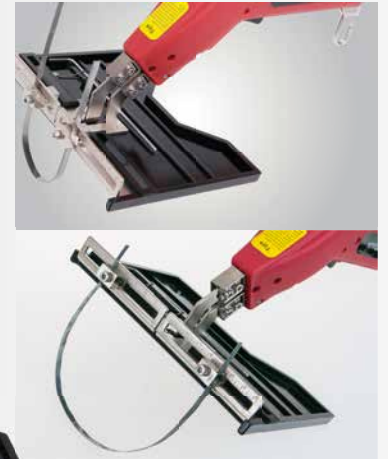

**FÜHRUNGSSCHIENE
FÜR STYROPORSCHNEIDER**
· für 35323, 35326



Nr.	Spezifikation	
35327	Führungsschiene	1
35335	Ersatzmesser - 30 cm	1

FESTA
POWER X TOOLS

ELEKTRISCHER STYROPORSCHNEIDER



· Temperaturregelung

Nr.	Spezifikation	
35325	220 W	1





FESTA

**SCHWEISSINVERTER
WIG/MMA 160 A**

Spannung/Frequenz:	230 V / 50 Hz
Leerlaufspannung:	55 V
Regelbereich der Schweißströme	10 - 160 A
Elektroden Durchmesser:	1,5 - 4,0 mm
Arbeitszyklus:	TIG- 160 A / 60%, MMA- 140 A / 60%
Schutzart:	IP 21
Schweißverfahren:	TIG/MMA
Abmessungen:	405 x 165 x 270 mm
Technologien:	Anti-stick, Arc-force, Hot start, Lift TIG
Gewicht:	6 kg



Nr.	Spezifikation
70040	Schweißinverter TIG/MMA 160A



FESTA

FESTA

**SELBSTDIMMENDER
SCHWEISSHELM**

Sichtfeldgröße:	98 x 80 mm
Dimmgeschwindigkeit des Filters:	1/25 000 s
Filterverdunklung:	DIN 5-8 / 9-13
UV/IR -Schutz:	DIN 16
Optische Klasse:	1 1 1 2
Anzahl Sensoren:	4
Spannungsversorgung:	Solarzelle + austauschbare CR2450-Batterie
Betriebsart:	Schweißen, Schleifen



LCD display



Nr.	Spezifikation
70064	aktiv
70066	Ersatzabdeckung aus Plexiglas





FESTA

SELBSTDIMMENDER SCHWEISSHELM - CARBON



Nr.	Spezifikation	Icon
70063	aktiv	4



SELBSTDIMMENDER HELM



Nr.	Spezifikation	Icon
70060	aktiv	4



SCHWEISSHELM



Nr.	Spezifikation	Icon
70061		4



ERSATZDECKGLAS FÜR DEN SCHWEISSHELM

2x

Nr.	Spezifikation	Icon
70065	113 x 80 mm	20



SCHWEISSBRILLE



Nr.	Spezifikation	Icon
70062		1

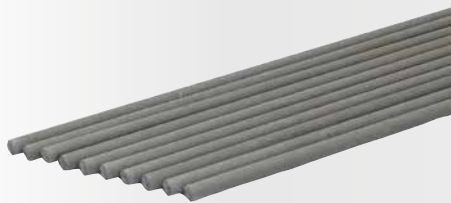

ER 117 RUTIL-ELEKTRODE

· zertifiziert

Nr.	Spezifikation	Menge	Icon
70021	Ø 2,0 x 300 mm	10 St.	1
70020	Ø 2,0 x 300 mm	2,5 kg	8
70026	Ø 2,5 x 300 mm	10 St.	1
70025	Ø 2,5 x 300 mm	2,5 kg	8
70033	Ø 3,2 x 350 mm	10 St.	1
70032	Ø 3,2 x 350 mm	5 kg	4



BASISCHE ELEKTRODE

· zertifiziert

Nr.	Spezifikation	Menge	Icon
70030	Ø 2,0 x 300 mm	2,5 kg	1
70031	Ø 2,0 x 300 mm	5 kg	1
70035	Ø 2,5 x 300 mm	2,5 kg	8
70036	Ø 2,5 x 300 mm	10 St.	1
70037	Ø 3,2 x 350 mm	5 kg	5



SCHWEISSHAMMER



Nr.	Spezifikation	Icon
19115	320 g	1



ELEKTRODENHALTER



Nr.	Spezifikation	Icon
70070	300 A	1



ERDUNGSZANGE



Nr.	Spezifikation	Icon
70075	300 A	1



FESTA

WINKELMAGNET



Nr.	Spezifikation	Tragfähigkeit	
70096	150 x 130 x 30 mm · 45°, 90°, 135°	25 kg	10

WINKELMAGNET



Nr.	Spezifikation	Tragfähigkeit	
70090	85 x 85 mm · 45°, 90°	9 kg	10



WINKELMAGNET



Nr.	Spezifikation	Tragfähigkeit	
70093	95 x 64 mm · 30°, 45°, 60°, 75°, 90°	9 kg	10
70094	120 x 90 mm · 30°, 45°, 60°, 75°, 90°	18 kg	10
70095	137 x 110 mm · 30°, 45°, 60°, 75°, 90°	27 kg	10

WINKELMAGNET



Nr.	Spezifikation	Tragfähigkeit	
70091	95 x 109 x 25 mm · 45°, 90°, 135°	13 kg	10
70092	130 x 150 x 32 mm · 45°, 90°, 135°	22 kg	5



FESTA
POWER X TOOLS

POLYFUSIONSSCHWEISSER VON KUNSTSTOFFFROHREN

- Spannung / Frequenz: 230 V / 50 Hz
- Leistungsaufnahme: 750 / 1500 W
- Temperatur: 0-300 C°
- Aufsätze: Ø 20,25,32,40,50,63 mm
- Gewicht: 1,6 kg



· im Lieferumfang enthalten: Maßband, Wasserwaage, Schraubendreher, Inbusschlüssel, Rohrschere, 6x Schweißaufsatz, Ständer, Blechboffer

Nr.	
17182	1

FESTA
POWER X TOOLS

SPITZEN-POLYFUSIONSSCHWEISSGERÄT FÜR KUNSTSTOFFFROHRE

- Spannung / Frequenz: 230 V / 50 Hz
- Leistungsaufnahme: 800 / 1000 W
- Temperatur: 0-300 C°
- Aufsätze: Ø 16, 20, 25, 32 mm
- Gewicht: 1 kg



· im Lieferumfang enthalten: Inbusschlüssel, 4x Schweißaufsatz, Ständer, Blechetui

Nr.	
17183	1

FESTA

KOMPRESSOR 6 L - ÖLFREI



Spannung/Frequenz:	230 V / 50Hz
Anschlusswert:	1,2 kW (1,5HP)
Volumen des Behälters:	6 l
Max Druck:	8 Bar
Drehzahl:	3900 min.
Saugleistung:	180 l/min.
Füllleistung:	116 l/min.
Gewicht:	10 kg



Nr.		
35360		1



KOMPRESSOR 24 L - ÖLFREI



Leistungsbereich:	1100 W
Spannungsversorgung:	230 V / 50Hz
Lauf ohne Last:	2850 min ⁻¹
Arbeitsdruck:	8 bar
Freie Luftzufuhr:	160 l / min
Typ:	ohne Öl
Magazinkapazität:	24 L
Gewicht:	23 kg

Nr.	Spezifikation	
35361	1,1 kW, 24 l	1



KOMPRESSOR 24 L



Leistungsbereich:	1500 W
Spannungsversorgung:	230 V / 50Hz
Lauf ohne Last:	2850 min ⁻¹
Arbeitsdruck:	8 bar
Freie Luftzufuhr:	200 l / min
Typ:	mit Öl
Magazinkapazität:	24 L
Gewicht:	24 kg

Nr.	Spezifikation	
35362	1,5 kW, 24 l	1



500 ml

FESTA

SPRITZPISTOLE

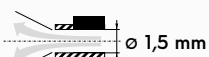

Nr.	Spezifikation	
48020	obere	1



600 ml

FESTA

SPRITZPISTOLE

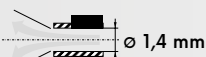

Nr.	Spezifikation	
48021	obere	1
48047	Ersatzdüse Ø 1,7 mm	1



1000 ml

FESTA

SPRITZPISTOLE



Nr.	Spezifikation	
48022	obere	1
48046	Ersatzdüse Ø 1,5 mm	1

FESTA
SPRITZPISTOLE



FARB- UND PUTZSPRITZPISTOLE

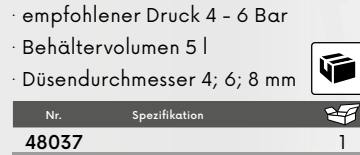

FESTA
AUSBLASPISTOLE MIT ADAPTERN

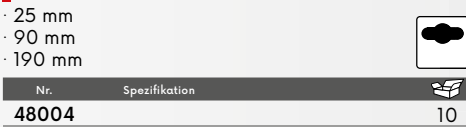

FESTA
BLASPISTOLE



FESTA
BLASPISTOLE



FESTA
BLASPISTOLE

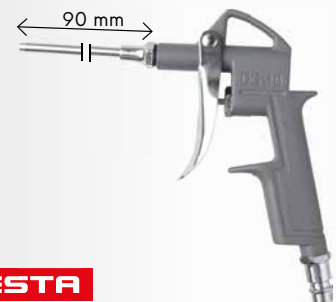

FESTA
SPRITZPISTOLE

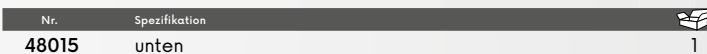

FESTA
BODEN- UND HOHLRAUMPISTOLE





FESTA

REIFENFÜLLER MIT DIGITALANZEIGE

- 0 - 10 bar
- LCD Anzeige
- bar, kPa, Psi, kgf/cm²

2x AAA

Nr.	Spezifikation	
48011	0 - 10 bar	10



FESTA

BLASPISTOLE MIT MANOMETER

Nr.	Spezifikation	
48010		1



FESTA

KOMPRESSOR-SET

5x

- 1. Spritzpistole mit unterem Behälter
- 2. Blaspistole mit Nanometer
- 3. Spritzpistole mit oberem Behälter
- 4. Blaspistole
- 5. Schlauch mit Schnellkupplungen

Nr.	Spezifikation	
48001		1



FESTA

KOMPRESSOR SET

3x

- 1. Blaspistole mit Nanometer
- 2. Blaspistole
- 3. Schlauch mit Schnellkupplungen

Nr.	Spezifikation	
48002		1

NEW

KOMPRESSOR-ADAPTER

8x

Nr.	Spezifikation	
48013		1



FESTA

SCHLAUCH MIT SCHNELLKUPPLUNGEN

Nr.	Spezifikation	
48043	5 m 8 atm ø 10 mm	1



FESTA

SCHLAUCH MIT SCHNELLKUPPLUNGEN

Nr.	Spezifikation	
48040	5 m 8 atm ø 8 mm	1
48041	10 m 8 atm ø 8 mm	1
48042	15 m 8 atm ø 8 mm	1



FESTA

DRUCST.CHLAUCH MIT SCHNELLKUPPLUNGEN
· max. 20 Bar

Nr.	Spezifikation	
48031	5 m ø 9/15 mm	1
48032	10 m ø 9/15 mm	1
48033	15 m ø 9/15 mm	1
48034	20 m ø 9/15 mm	1

FESTA

FILTER

· maximaler Druck 10 bar



Nr.	Spezifikation	
48008	G 1/4'	1

FESTA

DRUCKREGLER MIT MANOMETER

· Arbeitsdruck 0 - 10 bar



Nr.	Spezifikation	
48009	G 1/4'	1

FESTA

ERSATZDÜSE

· passend für 48021



Nr.	Spezifikation	
48047	Düse Ø 1,7 mm	1

FESTA

ERSATZDÜSE

· passend für 48022



Nr.	Spezifikation	
48046	Düse Ø 1,5 mm	1

GRÖSSENTABELLE FÜR WHITWORTH-ROHRGEWINDE

G - GEWINDEGRÖSSE IN ZOLL	MAXIMALER AUSSENGEWINDEDURCHMESSER IN MM
1/8	9,728
1/4	13,157
3/8	16,662
1/2	20,955
3/4	26,441
1	33,249

SCHNELLKUPPLUNG

Nr.	Spezifikation	
48075	1/4' außen	10
48076	3/8' außen	10
48077	1/2' außen	10
48095	1/4' innen	10
48096	3/8' innen	10
48097	1/2' innen	10

VERSCHRAUBUNGEN MIT AUSSENGEWINDE

Nr.	Spezifikation	
48050	Kupplung 1/4' außen x 1/4' außen	10
48051	Reduktion 1/4' außen x 3/8' außen	10

REDUKTION

Nr.	Spezifikation	
48054	3/8' außen x 1/4' innen	10
48055	1/2' außen x 3/8' innen	10
48056	Reduktion 3/8' außen x 1/2' innen	10
48057	Reduktion 1/4' außen x 3/8' innen	10

ADAPTER SCHNELLKUPPLUNG

Nr.	Spezifikation	
48080	1/4' außen	10
48081	3/8' außen	10
48090	3/8' innen	10
48091	1/4' innen	10

ADAPTER SCHNELLKUPPLUNG / SCHLAUCHNIPPEL

Nr.	Spezifikation	
48085	1/4' - 6 mm	10
48086	3/8' - 9 mm	10
48087	1/2' - 13 mm	10

SCHLAUCHNIPPEL

Nr.	Spezifikation	
48060	Ø 6 mm - 1/8' außen	10
48061	Ø 6 mm - 1/4' außen	10
48062	Ø 6 mm - 3/8' außen	10
48063	Ø 9 mm - 1/4' außen	10
48064	Ø 9 mm - 3/8' außen	10
48065	Ø 13 mm - 1/4' außen	10
48066	Ø 13 mm - 3/8' außen	10
48067	Ø 6 mm - 3/8' innen	10
48068	Ø 9 mm - 3/8' innen	10
48093	Ø 6 mm - 1/4' innen	10
48094	Ø 9 mm - 1/4' innen	10

AUSSENGESCHNELLKUPPLUNG / SCHLAUCHNIPPEL

Nr.	Spezifikation	
48070	1/4' - 6 mm	10
48071	3/8' - 9 mm	10
48072	1/2' - 13 mm	10

- digitale Anzeige



FESTA
POWER X TOOLS

**HEISSLUFTPISTOLE
MIT TEMPERATURREGELUNG**

Spannung / Frequenz	230V / 50Hz
Leistung	2000W
Schalterposition	0 - I (350°C) - II (550°C)
Zubehör	Edelstahlaufsätze - 4 St.

FESTA
POWER X TOOLS

**HEISSLUFTPISTOLE MIT TEMPERATUR- UND
LUFTSTROMREGELUNG**

Spannung / Frequenz	230V / 50Hz
Leistung	2000W
Schalterposition	0 - I (50°C) - II (50 - 600°C)
Luftstrom	120 - 500 l/min.
Zubehör	Edelstahlaufsätze - 4 St.



Nr.	Spezifikation	
35320	2000 W	1



Nr.	Spezifikation	
35322	2000 W	1

NEW



NEW



**WEST
BERG**
LÖTKOLBEN

230V
~ 50Hz **175W**



Nr.	Spezifikation	
28275		1
28278	Lötkolbenspitze 3 St.	1

**WEST
BERG**
LÖTKOLBEN

230V
~ 50Hz **60W**



Nr.	Spezifikation	
28280		1
28282	Lötkolbenspitze 2 St.	1



FESTA
POWER X TOOLS

**HEISSKLEBEPISTOLE
KABELLOS**

- Ø HeißklebesticSt. 11,2 mm

230V
~ 50Hz

80W



Nr. Spezifikation

89975

20

NEW



FESTA
POWER X TOOLS

HEISSKLEBEPISTOLE

- Ø HeißklebesticSt. 7,2 mm

230V
~ 50Hz

12W



Nr. Spezifikation

89775

1



HEISSKLEBEPISTOLE

- Ø HeißklebesticSt. 7,2 mm

230V
~ 50Hz

15W



Nr. Spezifikation

89970

25



HEISSKLEBEPISTOLE

- Ø HeißklebesticSt. 11,2 mm

230V
~ 50Hz

60W



Nr. Spezifikation

89973

20



HEISSKLEBESTICST. - KLAR

Nr.	Ø des Heißklebesticks	Dauer		
89980	7,2 mm	100 mm	12 St.	100
89988	7,2 mm	100 mm	1 kg	25



HEISSKLEBESTICST. - KLAR

Nr.	Ø des Heißklebesticks	Dauer		
89985	11,2 mm	200 mm	10 St.	50
89987	11,2 mm	200 mm	1 kg	25



HEISSKLEBESTICST. - BUNT

Nr.	Ø des Heißklebesticks	Dauer		
89989	7,2 mm	100 mm	12 St.	100
89990	11,2 mm	200 mm	10 St.	50



ELEKTRISCHER HEIZKÖRPER

Spannung	230V ~50Hz
Leistung	3300W
Stromlast	14.5A
Leistungseinstellung	30/1650/3300W
Temperaturbereich	5-40°C
Schutzart	IP24
Abmessungen	27 x 25.5 x 40cm
Gewicht	4.8 kg



- schnelle und effiziente Beheizung von Kellern, WerSt.tätten, Geschäften, Festzelten, Gewächshäusern usw.
- verbraucht keinen Sauerstoff
- sicherer Betrieb, stufenlose Leistungsregelung, Raumthermostat, Ventilator
- Edelstahl-Heizelement
- Einsatz im Sommer zur Belüftung ohne Heizung
- niedriger Lärmpegel
- hochwertige Verarbeitung, Materialien, robuste Stahlkonstruktion, einfache und sichere Handhabung, lange Lebensdauer



Nr.	Spezifikation
35833	3,3 kW



1

GASHEIZUNG

Gas	G30-I3B/P
Gasdruck	0.7bar
Nennspannung	230V 50Hz
Motorleistung	25W
maximaler Gasverbrauch	1.11 Kg/h
maximale Wärmeleistung	15KW
maximales Volumen an Heißluft	300m3/h

- schnelles und effizientes Heizen bei Bauarbeiten, in WerSt.tätten usw.
- verbraucht Sauerstoff!
- direkte Lufterwärmung mit Zwangsumwälzung - schnelle Wärmeentwicklung
- sicherer Betrieb, stufenlose Leistungsregelung
- Thermostat und Sicherheitsventil gegen Überhitzung und Gasaustritt
- einschließlich Zubehör - Regler und Gasversorgungsschlauch
- hochwertige Verarbeitung, Materialien, robuste Stahlkonstruktion, einfache und sichere Handhabung, lange Lebensdauer



Nr.	Spezifikation
35845	15 kW



1

GASHEIZUNG

Gas	g30-i3b/p
Gasdruck	1.5bar
Nennspannung	230v 50hz
Motorleistung	70w
maximaler Gasverbrauch	2.2kg/h
maximale Wärmeleistung	30kw
maximales Volumen an Heißluft	750m3/h

- schnelles und effizientes Heizen bei Bauarbeiten, in WerSt.tätten usw.
- verbraucht Sauerstoff!
- direkte Lufterwärmung mit Zwangsumwälzung - schnelle Wärmeentwicklung
- sicherer Betrieb, stufenlose Leistungsregelung
- Thermostat und Sicherheitsventil gegen Überhitzung und Gasaustritt
- einschließlich Zubehör - Regler und Gasversorgungsschlauch
- hochwertige Verarbeitung, Materialien, robuste Stahlkonstruktion, einfache und sichere Handhabung, lange Lebensdauer



Nr.	Spezifikation
35850	30 kW



1



FESTA

LED-BAULEUCHE



Nr.	Spezifikation	
37611		1



FESTA

LED-BAULEUCHE

· max. Höhe 180 cm

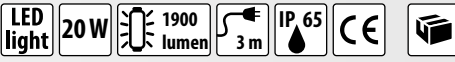

Nr.	Spezifikation	
37615	20 W	1
37616	2 x 20 W	1



NEW



FESTA
INDUSTRY

VERLÄNGERUNGSKABEL MIT TROMMEL

- rubber - IP44
- H07RN-F3G - 2,5mm²
- Ausgestattet mit Thermosicherung
- 16 A max. / 3680 W max.
- 4 Steckdosen

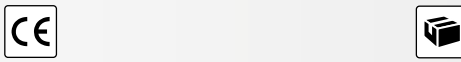

Nr.	Spezifikation	
37740	Länge 25 m, 2,5 mm ²	2
37741	Länge 50 m, 2,5 mm ²	2

NEW



FESTA
INDUSTRY

VERLÄNGERUNGSKABEL MIT TROMMEL

- rubber - IP44
- H05RR-F3G - 1,5mm²
- Ausgestattet mit Thermosicherung
- 16 A max. / 3680 W max.
- 4 Steckdosen

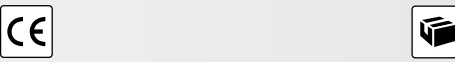

Nr.	Spezifikation	
37750	Länge 25 m, 1,5 mm ²	2
37751	Länge 50 m, 1,5 mm ²	2



FESTA

VERLÄNGERUNGSKABEL MIT TROMMEL

- IP20
- H05VV - F 3G 1,5mm²
- Ausgestattet mit Thermosicherung
- Leistungsaufnahme im aufgewickelten Zustand: max. 1000 W
- Leistungsaufnahme im ausgewickelten Zustand: max. 3000 W
- 4 Steckdosen



Nr.	Spezifikation	
37760	Länge 25 m, 1,5 mm ²	2
37761	Länge 50 m, 1,5 mm ²	2

FESTA
INDUSTRY

VERLÄNGERUNGSKABEL

- rubber - IP44
- H07RN-F3G - 1,5mm²
- 16 A max. / 3680 W max.



Nr.	Spezifikation	
37744	Länge 5 m, 1,5 mm ²	8
37745	Länge 10 m, 1,5 mm ²	4
37746	Länge 20 m, 1,5 mm ²	8
37747	Länge 30 m, 1,5 mm ²	8

NEW

FESTA

VERLÄNGERUNGSKABEL

- IP20
- H05VV-F3G - 1,5mm²
- 16 A max. / 3680 W max.



Nr.	Spezifikation	
37730	Länge 10 m, 1,5 mm ²	8
37731	Länge 20 m, 1,5 mm ²	4
37732	NEW Länge 30 m, 1,5 mm ²	8
37733	NEW Länge 40 m, 1,5 mm ²	4





BOHRER, SCHNEIDUND
SCHLEIFWERKZEUGE 54 - 93



FESTA

BOHRER IN METALL GESCHLIFFEN HSS-G KOBALT 5%

Co 5%, W 6%
Mo 5%, Cr 4%, V 4%

HSS **DIN 338** **135°**

INOX **1400 MPa**



Nr.	Spezifikation		Nr.	Spezifikation		Nr.	Spezifikation	
22510	Ø 1,00 mm	1	22548	Ø 4,80 mm	1	22590	Ø 9,00 mm	1
22515	Ø 1,50 mm	1	22550	Ø 5,00 mm	1	22595	Ø 9,50 mm	1
22520	Ø 2,00 mm	1	22555	Ø 5,50 mm	1	22600	Ø 10,00 mm	1
22525	Ø 2,50 mm	1	22560	Ø 6,00 mm	1	22602	Ø 10,20 mm	1
22530	Ø 3,00 mm	1	22565	Ø 6,50 mm	1	22605	Ø 10,50 mm	1
22532	Ø 3,20 mm	1	22568	Ø 6,80 mm	1	22610	Ø 11,00 mm	1
22535	Ø 3,50 mm	1	22570	Ø 7,00 mm	1	22615	Ø 11,50 mm	1
22540	Ø 4,00 mm	1	22575	Ø 7,50 mm	1	22620	Ø 12,00 mm	1
22542	Ø 4,20 mm	1	22580	Ø 8,00 mm	1	22625	Ø 12,50 mm	1
22545	Ø 4,50 mm	1	22585	Ø 8,50 mm	1	22630	Ø 13,00 mm	1

FESTA

BOHRER IN METALL GESCHLIFFEN HSS-G W 9%

W 9%, Mo 3%
Cr 4%, V 1%

HSS **DIN 338**

INOX **1100 MPa**



Nr.	Spezifikation		Nr.	Spezifikation		Nr.	Spezifikation		Nr.	Spezifikation	
19530	Ø 1,00 mm	10	19579	Ø 5,90 mm	5	19612	Ø 9,20 mm	5	19639	Ø 11,90 mm	3
19535	Ø 1,50 mm	10	19580	Ø 6,00 mm	5	19613	Ø 9,30 mm	5	19640	Ø 12,00 mm	3
19536	Ø 1,60 mm	10	19585	Ø 6,50 mm	5	19614	Ø 9,40 mm	5	19641	Ø 12,10 mm	3
19537	Ø 1,70 mm	10	19586	Ø 6,60 mm	5	19615	Ø 9,50 mm	3	19642	Ø 12,20 mm	3
19538	Ø 1,80 mm	10	19587	Ø 6,70 mm	5	19616	Ø 9,60 mm	3	19643	Ø 12,30 mm	3
19539	Ø 1,90 mm	10	19588	Ø 6,80 mm	5	19617	Ø 9,70 mm	3	19644	Ø 12,40 mm	3
19540	Ø 2,00 mm	10	19589	Ø 6,90 mm	5	19618	Ø 9,80 mm	3	19645	Ø 12,50 mm	3
19543	Ø 2,30 mm	10	19590	Ø 7,00 mm	5	19619	Ø 9,90 mm	3	19646	Ø 12,60 mm	1
19544	Ø 2,40 mm	10	19591	Ø 7,10 mm	5	19620	Ø 10,00 mm	3	19647	Ø 12,70 mm	1
19545	Ø 2,50 mm	10	19593	Ø 7,30 mm	5	19621	Ø 10,10 mm	3	19648	Ø 12,80 mm	1
19550	Ø 3,00 mm	10	19594	Ø 7,40 mm	5	19622	Ø 10,20 mm	3	19649	Ø 12,90 mm	1
19552	Ø 3,20 mm	10	19595	Ø 7,50 mm	5	19623	Ø 10,30 mm	3	19650	Ø 13,00 mm	1
19554	Ø 3,40 mm	10	19596	Ø 7,60 mm	5	19624	Ø 10,40 mm	3	19651	Ø 13,20 mm R13	1
19555	Ø 3,50 mm	10	19597	Ø 7,70 mm	5	19625	Ø 10,50 mm	3	19652	Ø 13,50 mm R13	1
19557	Ø 3,70 mm	10	19598	Ø 7,80 mm	5	19626	Ø 10,60 mm	3	19653	Ø 14,00 mm R13	1
19559	Ø 3,90 mm	10	19599	Ø 7,90 mm	5	19627	Ø 10,70 mm	3	19654	Ø 14,50 mm R13	1
19560	Ø 4,00 mm	10	19600	Ø 8,00 mm	5	19628	Ø 10,80 mm	3	19655	Ø 15,00 mm R13	1
19562	Ø 4,20 mm	10	19601	Ø 8,10 mm	5	19629	Ø 10,90 mm	3	19656	Ø 15,50 mm R13	1
19564	Ø 4,40 mm	10	19603	Ø 8,30 mm	5	19630	Ø 11,00 mm	3	19657	Ø 16,00 mm R13	1
19565	Ø 4,50 mm	10	19604	Ø 8,40 mm	5	19631	Ø 11,10 mm	3	19658	Ø 16,50 mm R13	1
19567	Ø 4,70 mm	10	19605	Ø 8,50 mm	5	19632	Ø 11,20 mm	3	19659	Ø 17,00 mm R13	1
19568	Ø 4,80 mm	10	19606	Ø 8,60 mm	5	19633	Ø 11,30 mm	3	19660	Ø 17,50 mm R13	1
19570	Ø 5,00 mm	5	19607	Ø 8,70 mm	5	19634	Ø 11,40 mm	3	19661	Ø 18,00 mm R13	1
19574	Ø 5,40 mm	5	19608	Ø 8,80 mm	5	19635	Ø 11,50 mm	3	19662	Ø 18,50 mm R13	1
19575	Ø 5,50 mm	5	19609	Ø 8,90 mm	5	19636	Ø 11,60 mm	3	19663	Ø 19,00 mm R13	1
19576	Ø 5,60 mm	5	19610	Ø 9,00 mm	5	19637	Ø 11,70 mm	3	19664	Ø 19,50 mm R13	1
19577	Ø 5,70 mm	5	19611	Ø 9,10 mm	5	19638	Ø 11,80 mm	3	19665	Ø 20,00 mm R13	1
19578	Ø 5,80 mm	5									

FESTA

BOX MIT GESCHLIFFENEN BOHRERN IN METALL HSS-G W 9%

W 9%, Mo 3%
Cr 4%, V 1%

HSS **DIN 338**

INOX **1100 MPa**

Nr.	Spezifikation	
19669		1
90191	ohne Bohrer	1



Nr.	Set-Inhalt	Nr.	Set-Inhalt
19530	Ø 1,00 mm 20x	19585	Ø 6,50 mm 15x
19535	Ø 1,50 mm 20x	19590	Ø 7,00 mm 15x
19540	Ø 2,00 mm 20x	19595	Ø 7,50 mm 15x
19545	Ø 2,50 mm 20x	19600	Ø 8,00 mm 15x
19550	Ø 3,00 mm 20x	19605	Ø 8,50 mm 15x
19552	Ø 3,20 mm 20x	19610	Ø 9,00 mm 15x
19555	Ø 3,50 mm 20x	19615	Ø 9,50 mm 15x
19558	Ø 3,80 mm 20x	19620	Ø 10,00 mm 15x
19560	Ø 4,00 mm 30x	19625	Ø 10,50 mm 6x
19562	Ø 4,20 mm 20x	19630	Ø 11,00 mm 6x
19565	Ø 4,50 mm 20x	19635	Ø 11,50 mm 6x
19568	Ø 4,80 mm 20x	19640	Ø 12,00 mm 6x
19570	Ø 5,00 mm 15x	19645	Ø 12,50 mm 6x
19575	Ø 5,50 mm 15x	19650	Ø 13,00 mm 6x
19580	Ø 6,00 mm 30x		

FESTA

BOHRER IN METALL GESCHLIFFEN

W 4%, Mo 3%
Cr 4%, V 1%

HSS

DIN
338



ALU

900
MPa



MOQ

Nr.	Spezifikation		Nr.	Spezifikation		Nr.	Spezifikation		Nr.	Spezifikation	
19670	Ø 0,6 mm	10	19703	Ø 4,0 mm	10	19736	Ø 7,3 mm	10	19769	Ø 10,6 mm	5
19671	Ø 0,8 mm	10	19704	Ø 4,1 mm	10	19737	Ø 7,4 mm	10	19770	Ø 10,7 mm	5
19672	Ø 0,9 mm	10	19705	Ø 4,2 mm	10	19738	Ø 7,5 mm	10	19771	Ø 10,8 mm	5
19673	Ø 1,0 mm	10	19706	Ø 4,3 mm	10	19739	Ø 7,6 mm	10	19772	Ø 11,0 mm	5
19674	Ø 1,1 mm	10	19707	Ø 4,4 mm	10	19740	Ø 7,7 mm	10	19773	Ø 11,2 mm	5
19675	Ø 1,2 mm	10	19708	Ø 4,5 mm	10	19741	Ø 7,8 mm	10	19774	Ø 11,3 mm	5
19676	Ø 1,3 mm	10	19709	Ø 4,6 mm	10	19742	Ø 7,9 mm	10	19775	Ø 11,4 mm	5
19677	Ø 1,4 mm	10	19710	Ø 4,7 mm	10	19743	Ø 8,0 mm	10	19776	Ø 11,5 mm	5
19678	Ø 1,5 mm	10	19711	Ø 4,8 mm	10	19744	Ø 8,1 mm	10	19777	Ø 11,6 mm	5
19679	Ø 1,6 mm	10	19712	Ø 4,9 mm	10	19745	Ø 8,2 mm	10	19778	Ø 11,7 mm	5
19680	Ø 1,7 mm	10	19713	Ø 5,0 mm	10	19746	Ø 8,3 mm	10	19779	Ø 11,8 mm	5
19681	Ø 1,8 mm	10	19714	Ø 5,1 mm	10	19747	Ø 8,4 mm	10	19780	Ø 11,9 mm	5
19682	Ø 1,9 mm	10	19715	Ø 5,2 mm	10	19748	Ø 8,5 mm	10	19781	Ø 12,0 mm	5
19683	Ø 2,0 mm	10	19716	Ø 5,3 mm	10	19749	Ø 8,6 mm	5	19782	Ø 12,2 mm	5
19684	Ø 2,1 mm	10	19717	Ø 5,4 mm	10	19750	Ø 8,7 mm	5	19783	Ø 12,5 mm	5
19685	Ø 2,2 mm	10	19718	Ø 5,5 mm	10	19751	Ø 8,8 mm	5	19784	Ø 12,8 mm	5
19686	Ø 2,3 mm	10	19719	Ø 5,6 mm	10	19752	Ø 8,9 mm	5	19785	Ø 12,9 mm	5
19687	Ø 2,4 mm	10	19720	Ø 5,7 mm	10	19753	Ø 9,0 mm	5	19786	Ø 13,0 mm	5
19688	Ø 2,5 mm	10	19721	Ø 5,8 mm	10	19754	Ø 9,1 mm	5	19787	Ø 13,2 mm R13	5
19689	Ø 2,6 mm	10	19722	Ø 5,9 mm	10	19755	Ø 9,2 mm	5	19788	Ø 13,5 mm R13	5
19690	Ø 2,7 mm	10	19723	Ø 6,0 mm	10	19756	Ø 9,3 mm	5	19789	Ø 14,0 mm R13	5
19691	Ø 2,8 mm	10	19724	Ø 6,1 mm	10	19757	Ø 9,4 mm	5	19790	Ø 14,5 mm R13	5
19692	Ø 2,9 mm	10	19725	Ø 6,2 mm	10	19758	Ø 9,5 mm	5	19791	Ø 15,0 mm R13	5
19693	Ø 3,0 mm	10	19726	Ø 6,3 mm	10	19759	Ø 9,6 mm	5	19792	Ø 15,5 mm R13	5
19694	Ø 3,1 mm	10	19727	Ø 6,4 mm	10	19760	Ø 9,7 mm	5	19793	Ø 16,0 mm R13	5
19695	Ø 3,2 mm	10	19728	Ø 6,5 mm	10	19761	Ø 9,8 mm	5	19794	Ø 16,5 mm R13	5
19696	Ø 3,3 mm	10	19729	Ø 6,6 mm	10	19762	Ø 9,9 mm	5	19795	Ø 17,0 mm R13	5
19697	Ø 3,4 mm	10	19730	Ø 6,7 mm	10	19763	Ø 10,0 mm	5	19796	Ø 17,5 mm R13	5
19698	Ø 3,5 mm	10	19731	Ø 6,8 mm	10	19764	Ø 10,1 mm	5	19797	Ø 18,0 mm R13	5
19699	Ø 3,6 mm	10	19732	Ø 6,9 mm	10	19765	Ø 10,2 mm	5	19798	Ø 18,5 mm R13	5
19700	Ø 3,7 mm	10	19733	Ø 7,0 mm	10	19766	Ø 10,3 mm	5	19799	Ø 19,0 mm R13	5
19701	Ø 3,8 mm	10	19734	Ø 7,1 mm	10	19767	Ø 10,4 mm	5	19800	Ø 19,5 mm R13	5
19702	Ø 3,9 mm	10	19735	Ø 7,2 mm	10	19768	Ø 10,5 mm	5	19801	Ø 20,0 mm R13	5

FESTA

BOX MIT GESCHLIFFENEN BOHRERN IN METALL HSS 4341

W 4%, Mo 3%
Cr 4%, V 1%

HSS

DIN
338



ALU

900
MPa



Nr.	Spezifikation	
19802		1
90192	ohne Bohrer	1

Nr.	Set-inhalt	Nr.	Set-inhalt
19673	Ø 1,00 mm 20x	19728	Ø 6,50 mm 20x
19678	Ø 1,50 mm 20x	19733	Ø 7,00 mm 10x
19683	Ø 2,00 mm 20x	19738	Ø 7,50 mm 10x
19688	Ø 2,50 mm 20x	19743	Ø 8,00 mm 10x
19693	Ø 3,00 mm 30x	19748	Ø 8,50 mm 10x
19695	Ø 3,20 mm 30x	19753	Ø 9,00 mm 10x
19698	Ø 3,50 mm 30x	19758	Ø 9,50 mm 10x
19701	Ø 3,80 mm 30x	19763	Ø 10,00 mm 10x
19703	Ø 4,00 mm 30x	19768	Ø 10,50 mm 10x
19705	Ø 4,20 mm 30x	19772	Ø 11,00 mm 10x
19708	Ø 4,50 mm 30x	19776	Ø 11,50 mm 10x
19711	Ø 4,80 mm 30x	19781	Ø 12,00 mm 10x
19713	Ø 5,00 mm 20x	19783	Ø 12,50 mm 10x
19718	Ø 5,50 mm 20x	19786	Ø 13,00 mm 5x
19723	Ø 6,00 mm 20x		

FESTA

BOHRER IN METALL, VERLÄNGERT

W 4%, Mo 3%
Cr 4%, V 1%

HSS

DIN
340



ALU



MOQ

Nr.	Spezifikation		Nr.	Spezifikation		Nr.	Spezifikation	
20220	Ø 2,0 mm x 85 mm	1	20245	Ø 4,5 mm x 126 mm	1	20280	Ø 8,0 mm x 165 mm	1
20225	Ø 2,5 mm x 95 mm	1	20250	Ø 5,0 mm x 132 mm	1	20290	Ø 9,0 mm x 175 mm	1
20230	Ø 3,0 mm x 100 mm	1	20255	Ø 5,5 mm x 139 mm	1	20296	Ø 10,0 mm x 184 mm	1
20235	Ø 3,5 mm x 110 mm	1	20260	Ø 6,0 mm x 139 mm	1			
20240	Ø 4,0 mm x 119 mm	1	20270	Ø 7,0 mm x 156 mm	1			

TIN-BOHRER IN METALL

Titanoberfläche für erhöhte Leistung und Haltbarkeit

TiN HSS DIN 338



Nr.	Spezifikation	
20400	Ø 1,0 mm	1
20401	Ø 1,5 mm	1
20402	Ø 2,0 mm	1
20403	Ø 2,5 mm	1
20404	Ø 3,0 mm	1
20405	Ø 3,2 mm	1
20406	Ø 3,5 mm	1
20407	Ø 3,8 mm	1
20408	Ø 4,0 mm	1
20409	Ø 4,2 mm	1
20410	Ø 4,5 mm	1

Nr.	Spezifikation	
20411	Ø 4,8 mm	1
20412	Ø 5,0 mm	1
20413	Ø 5,5 mm	1
20414	Ø 6,0 mm	1
20415	Ø 6,5 mm	1
20416	Ø 6,8 mm	1
20417	Ø 7,0 mm	1
20418	Ø 7,5 mm	1
20419	Ø 8,0 mm	1
20420	Ø 8,5 mm	1
20421	Ø 9,0 mm	1

Nr.	Spezifikation	
20422	Ø 9,5 mm	1
20423	Ø 10,0 mm	1
20424	Ø 10,2 mm	1
20425	Ø 10,5 mm	1
20426	Ø 11,0 mm	1
20427	Ø 11,5 mm	1
20428	Ø 12,0 mm	1
20429	Ø 12,5 mm	1
20430	Ø 13,0 mm	1

METALLBOHRER

HSS DIN 338

ALU



Nr.	Spezifikation	
19841	Ø 4,1 mm 5 ks	10
19842	Ø 4,2 mm 5 ks	10
19845	Ø 4,5 mm 5 ks	10
19885	Ø 8,5 mm 1 ks	10
19895	Ø 9,5 mm 1 ks	10



FESTA

SCHLEIFBOHRER FÜR METALL

W 9%, Mo 3% Cr 4%, V 1% HSS DIN 338

13x



Nr.	Spezifikation	
20333	Ø 1,5 - 6,5 mm	20



FESTA

SCHLEIFBOHRER FÜR METALL

W 9%, Mo 3% Cr 4%, V 1% HSS DIN 338

19x



Nr.	Spezifikation	
20334	Ø 1,0 - 10,0 mm	20



FESTA

SCHLEIFBOHRER FÜR METALL

W 9%, Mo 3% Cr 4%, V 1% HSS DIN 338

25x



Nr.	Spezifikation	
20335	Ø 1,0 - 13,0 mm	5



FESTA

METALLBOHRER

W 4%, Mo 3% Cr 4%, V 1% HSS DIN 338

13x



Nr.	Spezifikation	
20336	Ø 1,5 - 6,5 mm	1



FESTA

METALLBOHRER

W 4%, Mo 3% Cr 4%, V 1% HSS DIN 338

19x



Nr.	Spezifikation	
20337	Ø 1,0 - 10,0 mm	20



FESTA

METALLBOHRER

W 4%, Mo 3% Cr 4%, V 1% HSS DIN 338

25x



Nr.	Spezifikation	
20338	Ø 1,0 - 13,0 mm	10

FESTA

BOHRER-SET

TiN



9x

Nr.	Spezifikation
20317	Ø 5-6-8 mm



20



FESTA

BOHRER MIT SECHSKANTSCHAFT

1/4" HSS



7x

Nr.	Spezifikation
20316	Ø 1,5-2-3-4-5-5,5-6 mm



20



METALLBOHRER

HSS DIN 338



19x

Nr.	Spezifikation
20305	Ø 1,0 - 13,0 mm

25



METALLBOHRER

HSS DIN 338



25x

Nr.	Spezifikation
20311	Ø 1,0 - 13,0 mm

10



METALLBOHRER

HSS DIN 338



13x

Nr.	Spezifikation
20300	Ø 1,5 - 6,5 mm

50



METALLBOHRER

HSS DIN 338



19x

Nr.	Spezifikation
20310	Ø 1 - 13 mm

10



BOHRER UND BIT SET

- Holzbohrer Ø 3 · 4 · 5 · 6 · 8 mm
- Metallbohrer Ø 1 · 1,5 · 2 · 2,5 · 3 · 3,5 · 4 · 4,5 · 5 · 5,5 · 6 · 7 · 8 · 10 mm
- Steinbohrer Ø 4 · 5 · 6 · 8 · 10 mm
- flacher Holzbohrer Ø 16 · 22 · 25 mm
- Lochsäge Ø 32 · 38 · 44 · 54 mm
- Tiefenstopps Ø 6 · 8 · 10 mm
- Körner
- Bohrerdurchmesser-Messlehre

- Bit 25 mm
 - ⊖ S 3 · 4 · 4 · 5 · 5 · 6 · 6 · 7
 - ⊕ PH 0 · 0 · 1 · 1 · 2 · 2 · 2 · 3 · 3
 - ⊗ PZ 0 · 0 · 1 · 1 · 2 · 2 · 2 · 3 · 3
 - H 2 · 2,5 · 3 · 3,5 · 4 · 5 · 6
 - ⊗ T 10 · 15 · 20 · 25 · 27 · 30 · 40

- Bit 50 mm
 - ⊖ S 4 · 5 · 6 · 6
 - ⊕ PH 1 · 2 · 2 · 3
 - ⊗ PZ 1 · 2 · 2 · 3
- Adapter
 - 4 · 5 · 6 · 7 · 8 · 9 · 10 · 13 mm
- Entgrater
- Bithalter



METALLBOHRER

HSS DIN 338



19x

100x

Nr.	Spezifikation	Nr.	Spezifikation
20340		20315	Ø 1 - 10 mm

METALLBOHRER

TiN HSS DIN 338



19x



METALLBOHRER

HSS DIN 338



19x



Nr.	Spezifikation	Nr.	Spezifikation
20320	Ø 1 - 10 x 0,5 mm	20321	Ø 1 - 10 x 0,5 mm



BOHRERSPITZER

Nr.	Spezifikation
20380	für Ø 3,5 - 10 mm

FESTA BIMETALL RINGKRONE



Nr.	Spezifikation
24419	Ø 19 mm
24420	Ø 20 mm
24422	Ø 22 mm
24425	Ø 25 mm
24429	Ø 29 mm
24432	Ø 32 mm
24435	Ø 35 mm
24437	Ø 37 mm
24444	Ø 44 mm
24451	Ø 51 mm
24457	Ø 57 mm
24464	Ø 64 mm
24468	NEW Ø 68 mm
24476	Ø 76 mm
24483	Ø 83 mm



FESTA

MITNEHMER FÜR RINGKRONEN

Nr.	Spezifikation
24410	für Kronen 14 - 30 mm



FESTA

MITNEHMER FÜR RINGKRONEN

Nr.	Spezifikation
24411	für Kronen 32 - 152 mm



FESTA

BOHRER FÜR MITNEHMER FÜR RINGKRONEN

Nr.	Spezifikation
24412	pro 24410, 24411



FESTA

BIMETALL-RINGKRONEN SET

HSS



9x

Nr.	Spezifikation
24750	Ø 19, 22, 29, 38, 44, 57 mm



10

FESTA

BIMETALL-RINGKRONEN SET

HSS



13x

Nr.	Spezifikation
24751	Ø 19, 22, 29, 35, 38, 44, 51, 57, 64 mm



10



FESTA

TIN-STUFENBOHRER

TiN

HSS



Nr.	Spezifikation
20489	Ø 4 - 12 mm 9 Grad 20
20490	Ø 4 - 20 mm 9 Grad 10
20491	Ø 5 - 35 mm 13 Grad 10
20492	Ø 7 - 40,5 mm 13 Grad 5



FESTA

TIN-STUFENBOHRER-SET

TiN

HSS



3x

Nr.	Spezifikation
20495	Ø 4 - 12, 4 - 20, 4 - 32 mm



1

STUFENBOHRER

HSS



Nr.	Spezifikation
20487	Ø 4 - 20 mm 9 Grad 10
20488	Ø 5 - 35 mm 13 Grad 10
20494	Ø 4 - 32 mm 15 Grad 10
20493	Ø 7 - 40,5 mm 13 Grad 1



STUFENBOHRER-SET

HSS



3x

Nr.	Spezifikation
20496	Ø 4 - 12, 4 - 20, 4 - 32 mm



1



FESTA

ABZIEHER FÜR GEBOGENE SCHRAUBEN - SET

- Ø 4 mm Ø 11 mm
- Ø 4,5 mm Ø 15 mm
- Ø 6,5 mm Ø 19 mm
- Ø 7,5 mm Ø 24 mm

8x



Nr.	Spezifikation	
20387		5



FESTA

ABZIEHER FÜR GEBOGENE SCHRAUBEN - SET

- Ø 4 mm
- Ø 4,5 mm
- Ø 6 mm
- Ø 7,5 mm
- Ø 11 mm

5x



Nr.	Spezifikation	
20386		10



ABZIEHER FÜR GEBOGENE SCHRAUBEN - SET

- Ø 4 mm
- Ø 4,5 mm
- Ø 6 mm
- Ø 7,5 mm
- Ø 11 mm

5x



Nr.	Spezifikation	
20385		10



RATSCHEN-DREHKREUZ FÜR GEWINDEBOHRER

Nr.	Spezifikation	
20397	M3 - M8	10



FESTA

GEWINDEÖSENHALTER

DIN 225

Nr.	Spezifikation	
20396	25 x 9 mm	10



FESTA

VERSTELLBARES DREHKREUZ

DIN 1814

Nr.	Spezifikation	
20394	M5 - M20	10
20395	1 - 1/2; M3 - M12	10



FESTA

GEWINDEBOHRER UND GEWINDEÖSEN SET

32x



Nr.	Spezifikation	
20391	M 3, 4, 5, 6, 8, 10, 12 mm	1



FESTA

GEWINDEBOHRER-SET

21x



Nr.	Spezifikation	
20390	M 3, 4, 5, 6, 8, 10, 12 mm	1

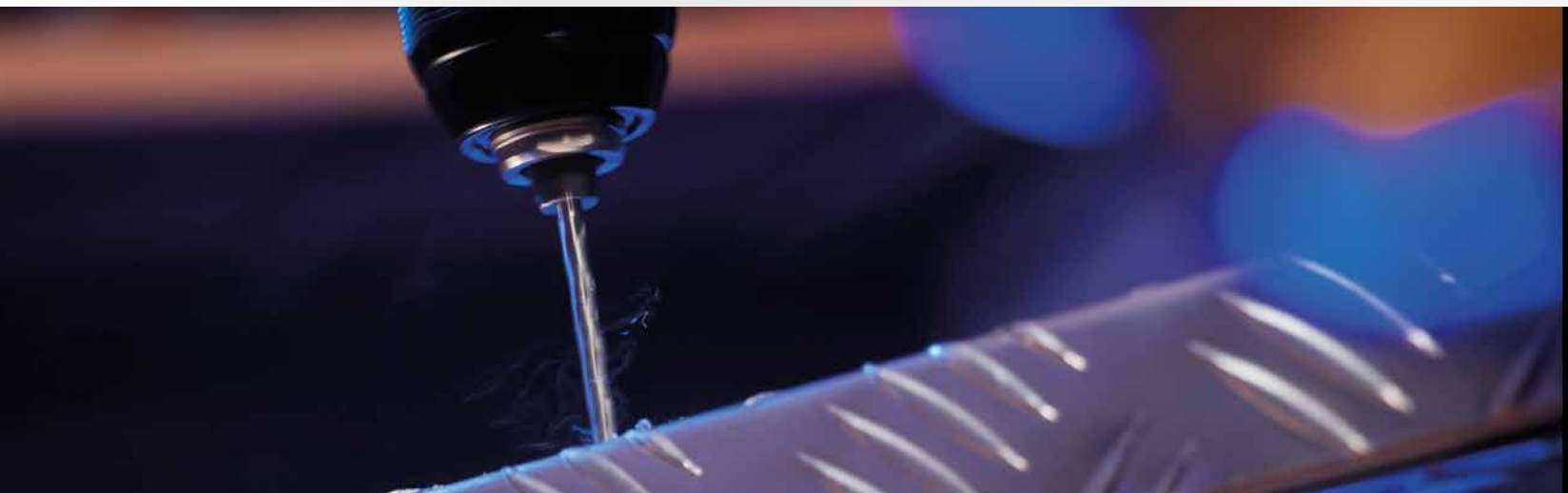

NEW

FESTA

FORSTNER-BOHRER

Nr.	Spezifikation	
21531	Ø 15 mm	1
21532	Ø 20 mm	1
21533	Ø 25 mm	1
21534	Ø 30 mm	1
21535	Ø 35 mm	1
21536	Ø 40 mm	1



FESTA

FESTA

SCHLANGENBOHRER INS HOLZ

Nr.	Spezifikation	
20980	Ø 6 x 230 mm	1
20957	Ø 6 x 300 mm	1
20981	Ø 8 x 230 mm	1
20958	Ø 8 x 300 mm	1
20982	Ø 10 x 230 mm	1
20896	Ø 10 x 300 mm	1
20913	Ø 10 x 450 mm	1
20983	Ø 12 x 230 mm	1
20897	Ø 12 x 300 mm	1
20915	Ø 12 x 450 mm	1
20920	Ø 12 x 600 mm	1
20898	Ø 14 x 300 mm	1
20916	Ø 14 x 450 mm	1
20921	Ø 14 x 600 mm	1

Nr.	Spezifikation	
20984	Ø 16 x 230 mm	1
20899	Ø 16 x 300 mm	1
20917	Ø 16 x 450 mm	1
20922	Ø 16 x 600 mm	1
20918	Ø 18 x 450 mm	1
20923	Ø 18 x 600 mm	1
20919	Ø 20 x 450 mm	1
20924	Ø 20 x 600 mm	1
20724	Ø 22 x 450 mm	1
20725	Ø 24 x 450 mm	1
20726	Ø 26 x 450 mm	1
20727	Ø 28 x 450 mm	1
20728	Ø 30 x 450 mm	1



FESTA

SCHLANGENBOHRER INS HOLZ SET

Nr.	Spezifikation	
20911	Ø 8, 10, 12, 14, 16 x 460 mm	10



FESTA

SCHLANGENBOHRER INS HOLZ - SET

Nr.	Spezifikation	
20912	Ø 6, 8, 10, 12, 16, 20 x 230 mm	10



HOLZBOHRER

Nr.	Spezifikation	
20729	Ø 6 x 400 mm	1
20731	Ø 8 x 400 mm	1
20736	Ø 8 x 600 mm	1
20730	Ø 10 x 400 mm	1
20737	Ø 10 x 600 mm	1

Nr.	Spezifikation	
20732	Ø 12 x 400 mm	1
20738	Ø 12 x 600 mm	1
20733	Ø 14 x 400 mm	1
20739	Ø 14 x 600 mm	1

Nr.	Spezifikation	
20734	Ø 16 x 400 mm	1
20740	Ø 16 x 600 mm	1
20735	Ø 18 x 400 mm	1
20741	Ø 18 x 600 mm	1



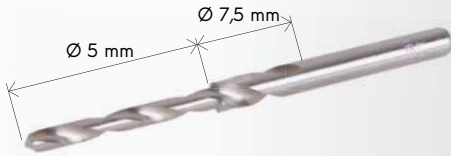

FESTA

**KONFIRMATBOHRER
GESCHLIFFEN**

HSS

Nr.	Spezifikation	
20210	Ø 7,5, 5 mm	1



HOLZBOHRER



Nr.	Spezifikation	
21440	Ø 4 x 75 mm	1
21441	Ø 5 x 85 mm	1
21442	Ø 6 x 90 mm	1
21443	Ø 7 x 105 mm	1
21444	Ø 8 x 115 mm	1
21445	Ø 9 x 120 mm	1
21446	Ø 10 x 120 mm	1



FRÄSBOHRER

HSS TiN



Nr.	Spezifikation	
20460	Ø 6 mm	50



**HOLZBOHRER
- SET**



Nr.	Spezifikation	
20910	8 Stck Ø 3, 4, 5, 6, 7, 8, 9, 10 mm	10
20905	5 Stck Ø 4, 5, 6, 8, 10 mm	10



ASTFÄNGER - SET



Nr.	Spezifikation	
21530	Ø 15, 20, 25, 30, 35 mm Ø 8 mm	20



**FRÄS-
BOHRER
- SET**

HSS TiN



Nr.	Spezifikation	
20450	Ø 3, 4, 5, 6, 6.5, 8 mm	20

SPITZBOHRER INS HOLZ - SET



6x

Nr.	Spezifikation	
20901	Ø 10, 12, 16, 18, 20, 25 mm	20



BOHRER - SET

HOBBY

4x

Nr.	Spezifikation	
20381	Ø 2, 3, 4, 5 mm	20





FESTA

KREISSÄGEN

- Ø 19 mm
- Ø 22 mm
- Ø 25 mm
- Ø 35 mm
- Ø 44 mm
- Ø 51 mm
- Ø 60 mm
- Ø 67 mm
- Ø 76 mm
- Ø 82 mm
- inbus
- 2x Kopf



12x



Nr.	Spezifikation	
24712	6 tpi	20



FESTA

KREISSÄGEN

- Ø 64 mm
- Ø 76 mm
- Ø 89 mm
- Ø 102 mm
- Ø 127 mm
- inbus
- Kopf



8x



Nr.	Spezifikation	
24706	6 tpi	20



FESTA

RINGFÖRMIGE KRONE EINSTELLBAR

Ø 19 - 127 mm



Nr.	Spezifikation	
24415	Ø 19 - 127 mm	max. hĺoubka 29 mm

FESTA

KREISSÄGE FÜR HOLZ UND GIPSKARTON



Nr.	Spezifikation	
24715	1' Ø 67 mm	6 tpi
24713	1' Ø 73 mm	6 tpi
24714	1' Ø 102 mm	6 tpi
24720	1' Ø 152 mm	6 tpi



KREISSÄGEN - SET

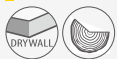

Nr.	Spezifikation	
24721	1' Ø 26, 32, 38, 45, 50, 56, 63 mm	10
24722	2' Ø 26, 32, 38, 45, 50, 56, 63 mm	10

KREISSCHNEIDER, EINSTELLBAR



Nr.	Spezifikation	
24716	Ø 30 - 120 mm	5

FESTA

ZYLINDER RASPEL

M14

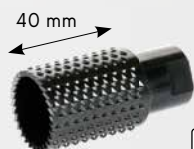

Nr.	Spezifikation	
21807	Ø 30 mm / 60 mm	1

FESTA

KUGELRASPEL

M14



Nr.	Spezifikation	
21808	Ø 30 mm / 105 mm	10



ROTATIONS-RASPEL

5x



Nr.	Spezifikation	
21541		25



RUNDSCHLEIFER

5x

Nr.	Spezifikation	
21540	Ø 3 mm, 6 mm	12

AUFSÄTZE FÜR DIREKTSCHLEIFER

190x



Nr.	Spezifikation	
24755		5



AUFSÄTZE FÜR DIREKTSCHLEIFER

150x

Nr.	Spezifikation	
24756		10



FORMSCHNEIDER FÜR HOLZ



5x



Nr.	Spezifikation	
21450	Ø 8 mm	10



FORMSCHNEIDER FÜR HOLZ



12x

Nr.	Spezifikation	
21451	Ø 8 mm	10



FORMSCHNEIDER FÜR HOLZ



24x

Nr.	Spezifikation	
21452	Ø 8 mm	1



FORMSCHNEIDER FÜR HOLZ



35x

Nr.	Spezifikation	
21453	Ø 8 mm	1



FORMSCHNEIDER FÜR HOLZ



59x

Nr.	Spezifikation	
21454	Ø 8 mm	1



FESTA

WIDIA-SCHLAGBOHRER

DIN 8039



· zweischneidiger Bohrer



Nr.	Spezifikation	A mm	B mm	
20673	Ø 3 mm	60	30	100
20674	Ø 4 mm	75	40	100
20675	Ø 5 mm	85	50	100
20676	Ø 6 mm	100	60	100
20677	Ø 6 mm	200	160	50
20685	Ø 6 mm	300	260	50
20678	Ø 8 mm	120	75	50
20686	Ø 8 mm	200	155	50

Nr.	Spezifikation	A mm	B mm	
20687	Ø 8 mm	300	255	25
20688	Ø 8 mm	400	340	25
20680	Ø 10 mm	120	70	50
20690	Ø 10 mm	200	150	50
20691	Ø 10 mm	300	250	25
20692	Ø 10 mm	400	340	25
20682	Ø 12 mm	150	100	50
20694	Ø 12 mm	300	250	25

Nr.	Spezifikation	A mm	B mm	
20696	Ø 12 mm	400	340	25
20684	Ø 14 mm	150	90	25
	Reduktion Ø 10 mm			
20697	Ø 14 mm	300	240	5
	Reduktion Ø 10 mm			
20698	Ø 14 mm	400	340	15
	Reduktion Ø 10 mm			

FESTA

WIDIA-SCHLAGBOHRER SDS+

SDS+



· zweischneidiger Bohrer



Nr.	Spezifikation	A mm	B mm	
20855	Ø 14 mm	160	75	

Nr.	Spezifikation	A mm	B mm	
				25

Nr.	Spezifikation	A mm	B mm	
				25

FESTA

WIDIA-SCHLAGBOHRER SDS+

SDS+

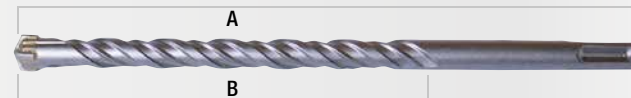

· vierschneidiger Bohrer mit erhöhter Leistung und Haltbarkeit



Nr.	Spezifikation	A mm	B mm	
20748	Ø 6 mm	110	40	50
20749	Ø 6 mm	160	90	50
20750	Ø 6 mm	210	140	50
20751	Ø 6 mm	260	190	50
20861	Ø 6,5 mm	230	160	50
20862	Ø 6,5 mm	300	230	50
20752	Ø 8 mm	110	40	50
20753	Ø 8 mm	160	90	50
20754	Ø 8 mm	210	140	50
20755	Ø 8 mm	260	190	50
20825	Ø 8 mm	350	280	50
20756	Ø 10 mm	160	90	50
20757	Ø 10 mm	210	140	50
20758	Ø 10 mm	260	190	50
20759	Ø 10 mm	350	280	50
20760	Ø 10 mm	450	380	50
20761	Ø 10 mm	600	530	50
20762	Ø 10 mm	1000	930	50
20764	Ø 12 mm	160	80	50
20765	Ø 12 mm	210	130	50
20766	Ø 12 mm	260	180	50
20767	Ø 12 mm	350	270	50

Nr.	Spezifikation	A mm	B mm	
20768	Ø 12 mm	460	380	50
20769	Ø 12 mm	600	520	25
20770	Ø 12 mm	1000	920	25
20771	Ø 14 mm	160	80	25
20772	Ø 14 mm	260	180	25
20773	Ø 14 mm	350	270	25
20774	Ø 14 mm	460	380	25
20775	Ø 14 mm	600	520	25
20776	Ø 14 mm	1000	920	30
20777	Ø 16 mm	160	80	25
20778	Ø 16 mm	210	130	25
20779	Ø 16 mm	260	180	25
20780	Ø 16 mm	350	270	25
20781	Ø 16 mm	460	380	25
20782	Ø 16 mm	600	520	30
20783	Ø 16 mm	1000	920	25
20784	Ø 18 mm	260	180	25
20785	Ø 18 mm	450	370	25
20786	Ø 18 mm	600	520	32
20787	Ø 18 mm	1000	920	20
20788	Ø 20 mm	450	370	20
20789	Ø 20 mm	600	520	20

Nr.	Spezifikation	A mm	B mm	
20790	Ø 20 mm	800	720	25
20791	Ø 20 mm	1000	920	10
20792	Ø 22 mm	450	365	20
20793	Ø 22 mm	600	520	20
20794	Ø 22 mm	800	715	20
20795	Ø 22 mm	1000	920	10
20796	Ø 24 mm	450	365	10
20797	Ø 24 mm	600	520	20
20798	Ø 24 mm	800	715	10
20799	Ø 24 mm	1000	920	10
20870	Ø 26 mm	450	370	10
20871	Ø 26 mm	650	570	20
20872	Ø 26 mm	800	720	10
20873	Ø 26 mm	1000	920	10
20874	Ø 28 mm	450	365	10
20875	Ø 28 mm	600	565	20
20876	Ø 28 mm	800	715	10
20877	Ø 28 mm	1000	915	10
20878	Ø 30 mm	450	365	10
20879	Ø 30 mm	600	565	20
20880	Ø 30 mm	800	715	10
20881	Ø 30 mm	1000	915	10

FESTA

WIDIA-SCHLAGBOHRER SDS MAX

SDS MAX

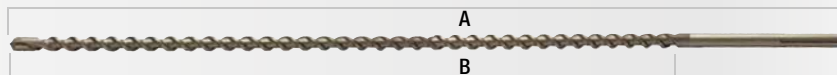

· vierschneidiger Bohrer mit erhöhter Leistung und Haltbarkeit



Nr.	Spezifikation	A mm	B mm	
20508	Ø 16 mm	550	395	5
20510	Ø 18 mm	550	395	5
20520	Ø 18 mm	800	650	5
20511	Ø 20 mm	550	395	5
20521	Ø 20 mm	800	650	5

Nr.	Spezifikation	A mm	B mm	
20512	Ø 22 mm	550	395	5
20522	Ø 22 mm	800	650	5
20513	Ø 24 mm	550	395	5
20523	Ø 24 mm	800	650	5
20514	Ø 28 mm	550	395	5

Nr.	Spezifikation	A mm	B mm	
20524	Ø 28 mm	800	650	5
20515	Ø 30 mm	550	395	5
20525	Ø 30 mm	800	650	5
20516	Ø 40 mm	550	395	2
20526	Ø 40 mm	800	650	1

**MAUERBOHRER-SET
SDS+**

5x SDS+



Nr.	Spezifikation		
20890	Ø 5, 6, 8, 10, 12 mm	160 mm	25

**PRÄSENTATIONS-
STÄNDER**

Nr.	Spezifikation	
20999		1

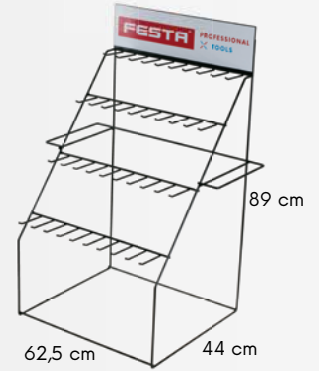

**MAUERBOHRER-SET
SDS+**

6x SDS+



Nr.	Spezifikation		
20891	Ø 5, 6, 8 mm Ø 8, 10, 12 mm	110 mm 160 mm	25

**MAUERBOHRER
SET**

6x DIN 8039



Nr.	Spezifikation	
20895	Ø 5, 6, 8, 10, 12 mm	25

**MAUERBOHRER
SET**



Nr.	Spezifikation	
20805	5 Stck Ø 4 - 10 mm	10
20820	8 Stck Ø 3 - 10 mm	10



MEISSEL-SET

SDS+

4x



Nr.	Spezifikation	
20954	250 mm	1

**MEISSEL UND
BOHRER SDS+**

- 2 x Spitzseisen
- 3 x Meißel
- 12 x Bohrer

17x SDS+



Nr.	Spezifikation	
20952		1

MEISSEL UND BOHRER SDS+

- 1 x Spitzseisen 250 mm
- 1 x Nutenstanzmaschine 22 x 250 mm
- 1 x Flach 20 x 250 mm

- Ø 5 x 110 mm
- Ø 6 x 110 mm
- Ø 8 x 160 mm
- Ø 10 x 160 mm
- Ø 12 x 160 mm
- Ø 14 x 210 mm
- Ø 16 x 210 mm
- Ø 18 x 310 mm
- Ø 20 x 450 mm

12x SDS+



Nr.	Spezifikation	
20950		5

FLACHMEISSEL SDS +

SDS+



Nr.	Spezifikation	
20996	250 x 100 mm	1



NEW



FESTA
MEISSEL

SDS+

Nr.	Spezifikation	
20997	445 x 130 mm	1

NEW



FESTA
MEISSEL

SDS MAX

Nr.	Spezifikation	
20932	450 x 100 mm	1

FESTA

FLACHMEISSEL, GEBOGEN 15°

SDS+

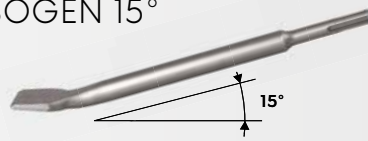

Nr.	Spezifikation	
20936	40 x 250 mm	5

FESTA

MEISSEL

SDS+



Nr.	Spezifikation	
20948	20 x 250 mm	25
20990	20 x 400 mm	25
20949	40 x 250 mm	25
20991	40 x 400 mm	25

FESTA

MEISSEL

SDS MAX



Nr.	Spezifikation	
20940	25 x 280 mm	5
20941	40 x 280 mm	5
20942	75 x 280 mm	5
20943	25 x 400 mm	5
20944	40 x 400 mm	5
20945	25 x 600 mm	5
20946	50 x 600 mm	5

FESTA

SPITZEISEN

SDS+



Nr.	Spezifikation	
20947	250 mm	25
20992	400 mm	25

FESTA

SPITZEISEN

SDS MAX



Nr.	Spezifikation	
20937	∅ 18 x 280 mm	5
20938	∅ 18 x 400 mm	5
20939	∅ 18 x 600 mm	2

FESTA

RINGKRONE MIT SK-SCHEIBEN

SDS+



Nr.	Spezifikation	
24719	∅ 67 mm	1
24717	∅ 73 mm	1
24723	∅ 80 mm	1
24718	∅ 100 mm	1
24757	∅ 115 mm	1
24758	∅ 125 mm	1
24759	∅ 150 mm	1

- Kronen können mit den Schäften 24730, 24731 und 24732 verwendet werden

FESTA

NUTENSTANZMASCHINE

SDS+



Nr.	Spezifikation	
20956	22 x 250 mm	25

FESTA

EINSPANNSCHAFT FÜR RINGKRONEN

SDS MAX



Nr.	Spezifikation	
24730	180 mm	1

FESTA

EINSPANNSCHAFT FÜR RINGKRONEN

SDS+



Nr.	Spezifikation	
24731	300 mm	1
24732		1



FESTA

KARBID-RINGKRONEN - SET



6x



Nr.	Spezifikation	
24745	Ø 33, 53, 67, 73 mm + Mitnehmer, Bohrer	1



FESTA

KARBID-RINGKRONEN - SET



8x

Nr.	Spezifikation	
24747	Ø 33, 53, 67, 73, 83 mm Mitnehmer, Bohrer, Feile	1

FESTA

KARBID RINGKRUNE

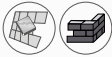

Nr.	Spezifikation	
24735	Ø 33 mm	1
24736	Ø 43 mm	1
24737	Ø 53 mm	1
24738	Ø 67 mm	1
24739	Ø 73 mm	1
24740	Ø 83 mm	1
24741	Ø 103 mm	1



FESTA

KARBID RINGKRUNE SET

3x



Nr.	Spezifikation	
24746	Ø 103 mm + Mitnehmer, Bohrer	1



FESTA

BOHRER FÜR RINGKRONEN



Nr.	Spezifikation	
24749		50



FESTA

MITNEHMER FÜR RINGKRONEN



Nr.	Spezifikation	
24748	Ø 33 - 83 mm	10
24743	Ø 33 - 103 mm	10



FESTA

KARBID-BOHRKRONE

· zum Bohren in Glas und Keramik
· erforderliche Kühlung



Nr.	Spezifikation	
24770	Ø 4 mm	1
24771	Ø 6 mm	1
24772	Ø 8 mm	1
24773	Ø 10 mm	1
24774	Ø 12 mm	1



VERSTELLBARER KREISSCHNEIDER MIT ABDECKUNG

Nr.	Spezifikation	
24726	Ø 20-95mm	1

KREISSCHNEIDER, EINSTELLBAR

Nr.	Spezifikation	
24725	Ø 20-95mm	10



FESTA

FEILE FÜR FLIESEN UND PFLASTER



Nr.	Spezifikation	
22200	160 mm	20



FESTA

FLACHFEILE FÜR FLIESEN, PFLASTER UND MAUERWERK

· zum Schleifen von Ziegeln vor dem Einsetzen der Wandverankerung



Nr.	Spezifikation	
22201	200 mm doppelte Rauheit	20





DIAMANT-LOCHSÄGE SATZ

- Ø 6 mm
- Ø 8 mm
- Ø 10 mm
- Ø 12 mm
- Ø 20 mm
- Ø 28 mm
- Ø 35 mm
- Ø 45 mm
- Ø 55 mm
- Ø 68 mm

Trenn-/Schleifscheibe Ø 125 mm x 2,0 mm Ø 22,2 mm
 Trennscheibe Ø 125 mm x 1,2 mm Ø 22,2 mm
 Diamant-Schleifkegel Ø 0 - 50 mm
 Diamant-Schleifschwammblock 90 x 55 mm P60

13x M14

- Keramikfliesen und Pflaster
- Marmor
- Granit

· Es ist keine Kühlung mit Wasser erforderlich



Nr.	Spezifikation	
24652		1



DIAMANT-LOCHSÄGE

M14

- Keramikfliesen und Pflaster
- Marmor
- Granit

· Es ist keine Kühlung mit Wasser erforderlich



Nr.	Spezifikation	
24620	Ø 6 mm	M14
24621	Ø 8 mm	M14
24622	Ø 10 mm	M14
24623	Ø 12 mm	M14
24624	Ø 14 mm	M14
24627	Ø 20 mm	M14
24630	Ø 28 mm	M14
24633	Ø 35 mm	M14
24636	Ø 45 mm	M14
24638	Ø 55 mm	M14
24640	Ø 68 mm	M14
24642	NEW Ø 72 mm	M14
24643	Ø 75 mm	M14



DIAMANT-LOCHSÄGE SATZ

- Ø 6 mm
- Ø 8 mm
- Ø 10 mm
- Ø 20 mm
- Ø 35 mm
- Ø 45 mm
- Ø 55 mm
- Ø 68 mm

8x M14

- Keramikfliesen und Pflaster
- Marmor
- Granit

· Es ist keine Kühlung mit Wasser erforderlich



Nr.	Spezifikation	
24651		1



DIAMANT SCHLEIFSTIFT

M14

- Keramikfliesen und Pflaster
- Marmor
- Granit

· Es ist keine Kühlung mit Wasser erforderlich



Nr.	Spezifikation	
24795	Ø 20 / 50 mm	1
24797	Ø 6 / 50 mm	1
24799	Ø 10 / 50 mm	1



DIAMANT SCHLEIFKEGEL

M14

- Keramikfliesen und Pflaster
- Marmor
- Granit

· Es ist keine Kühlung mit Wasser erforderlich



Nr.	Spezifikation	
24775	NEW Ø 2 - 35 mm	1
24777	Ø 2 - 75 mm	1
24778	Ø 2 - 50 mm	1





DIAMANT-RINGKRON



M14

- Keramikverkleidungen
- Marmor
- Granit

Verwendung ohne Wasserkühlung



Nr.	Spezifikation	1
24779	Ø 20 - 48 mm	1



DIAMANT SCHLEIFKRONE



NEW

M14

- Keramikverkleidungen
- Marmor
- Granit

Verwendung ohne Wasserkühlung



Nr.	Spezifikation	1
24663	Ø 50 mm	1



DIAMANT-RINGKRUNE



M14

- Keramikverkleidungen
- Marmor
- Granit

Verwendung ohne Wasserkühlung



Nr.	Spezifikation	üchyt	1	Nr.	Spezifikation	üchyt	1
24760	Ø 6 mm	M14	1	24766	Ø 35 mm	M14	1
24761	Ø 8 mm	M14	1	24776	Ø 40 mm	M14	1
24762	Ø 10 mm	M14	1	24767	Ø 45 mm	M14	1
24763	Ø 12 mm	M14	1	24791	Ø 50 mm	M14	1
24764	Ø 14 mm	M14	1	24768	Ø 53 mm	M14	1
24670	Ø 16 mm	M14	1	24792	Ø 60 mm	M14	1
24671	Ø 18 mm	M14	1	24793	Ø 65 mm	M14	1
24790	Ø 20 mm	M14	1	24769	Ø 68 mm	M14	1
24672	Ø 22 mm	M14	1	24794	Ø 75 mm	M14	1
24673	Ø 25 mm	M14	1	24796	Ø 83 mm	M14	1
24765	Ø 28 mm	M14	1	24677	Ø102 mm	M14	1
24674	Ø 30 mm	M14	1	24676	Ø 110 mm	M14	1
24675	Ø 32 mm	M14	1	24678	Ø125 mm	M14	1



DIAMANT SCHLEIFKRONE



NEW

M14

- Keramikverkleidungen
- Marmor
- Granit

Verwendung ohne Wasserkühlung



Nr.	Spezifikation	1
24661	Ø 50 mm	1



DIAMANT-RINGKRUNE, SET



- Ø 8 mm
- Ø 10 mm
- Ø 14 mm
- Ø 22 mm
- Ø 32 mm
- Ø 40 mm
- Ø 68 mm

7x M14

- Keramikverkleidungen
- Marmor
- Granit

Verwendung ohne Wasserkühlung



Nr.	Spezifikation	1
24650		1



DIAMANT-RINGKRUNE

- Keramikverkleidungen
- Marmor
- Granit



Nr.	Spezifikation	1
24700	Ø 6 mm	1
24701	Ø 8 mm	1
24702	Ø 10 mm	1
24703	Ø 12 mm	1
24704	Ø 14 mm	1
24705	Ø 20 mm	1



FESTA

KÜHLENDES WACHS
FÜR
DIAMANT-LOCHSÄGE



Nr.	Spezifikation	
24710	30 ml	1

FESTA

DIAMANT-
RINGKRONE
SET



6x

- Keramikverkleidungen
- Marmor
- Granit

Nr.	Spezifikation	
24798	Ø 6, 8, 10, 12, 14, 20 mm	1



FESTA

DIAMANT-
TRENNSCHEIBE

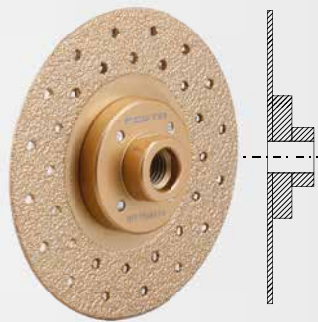

M14

- Keramikverkleidungen
- Marmor
- Granit

- Verwendung ohne Wasserkühlung

Nr.	Spezifikation	
24655	Ø 115 mm M14	1

FESTA

DIAMANT-
TRENNSCHEIBE

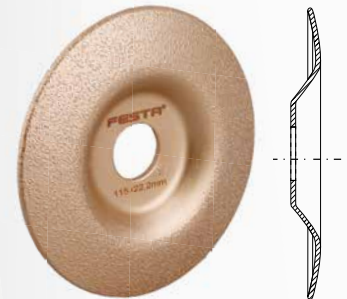

- Keramikverkleidungen
- Marmor
- Granit

- Verwendung ohne Wasserkühlung

Nr.	Spezifikation	
24658	Ø 115 mm Ø 22,2 mm	1

FESTA

BOHRER FÜR GLAS
UND KERAMIK

TiN 1/4"

- Keramikfliesen und Pfaster
- Marmor
- Granit

Nr.	Spezifikation	
24780	Ø 4 mm	40
24781	Ø 5 mm	40
24782	Ø 6 mm	40
24783	Ø 8 mm	40
24784	Ø 10 mm	40
24785	Ø 12 mm	40
24786	Ø 14 mm	1
24787	Ø 16 mm	1
24788	Ø 18 mm	1
24789	Ø 20 mm	1



FESTA

BOHRER FÜR GLAS
UND KERAMIK, SET

- Ø 4 mm
- Ø 5 mm
- Ø 6 mm
- Ø 8 mm
- Ø 10 mm

5x

- Keramikfliesen und Pfaster
- Marmor
- Granit

- Es ist keine Kühlung mit Wasser erforderlich

Nr.	Spezifikation	
24734		1





DIAMANT SCHNEID-/SCHLEIFSCHEIBE

- Keramikfliesen und Pflaster
- Marmor
- Granit

Es ist keine Kühlung mit Wasser erforderlich



Nr.	Spezifikation		
21230	Ø 115 mm x 1,8 mm	Ø 22,2 mm	1
21231	Ø 125 mm x 2,0 mm	Ø 22,2 mm	1



DIAMANT-TRENNSCHEIBE TURBO EXTREM

- verstärkter Beton
- Keramikfliesen und Pflaster
- Marmor
- Granit

Es ist keine Kühlung mit Wasser erforderlich

Nr.	Spezifikation		
21205	Ø 125 mm x 2,0 mm	Ø 22,2 mm	1
21209	Ø 230 mm x 2,6 mm	Ø 22,2 mm	1



DIAMANT-TRENNSCHEIBE

- Keramikfliesen und Pflaster
- Marmor
- Granit

Es ist keine Kühlung mit Wasser erforderlich



Nr.	Spezifikation		
21234 NEW	Ø 115 mm x 1,2 x 8 mm	Ø 22,2 mm	1
21235	Ø 125 mm x 1,2 x 8 mm	Ø 22,2 mm	1
21238 NEW	Ø 200 mm x 1,6 x 11 mm	Ø 25,4 mm	1



DIAMANTSCHLEIFSCHEIBE

- Keramikfliesen und Pflaster
- Marmor
- Granit

Es ist keine Kühlung mit Wasser erforderlich

Nr.	Spezifikation		
21200	Ø 115 mm 1,4 mm	Ø 22,2 mm	1
21201	Ø 125 mm 1,4 mm	Ø 22,2 mm	1
21204	Ø 200 mm 1,8 mm	Ø 25,4 mm	1
21203	Ø 230 mm 1,8 mm	Ø 22,2 mm	1



FESTA

VOLLDIAMANTSCHLEIBE



Nr.	Spezifikation	
21311	Ø 115 mm Ø 22,2 mm	1
21312	Ø 125 mm Ø 22,2 mm	1
21315	Ø 150 mm Ø 22,2 mm	1
21318	Ø 180 mm Ø 22,2 mm	1
21323	Ø 230 mm Ø 22,2 mm	1
21324	Ø 300 mm Ø 25,4 mm	1
21327	Ø 350 mm Ø 25,4 mm	1
21326	Ø 400 mm Ø 25,4 mm	1



FESTA

TURBO-DIAMANTSCHLEIBE



Nr.	Spezifikation	
21411	Ø 115 mm Ø 22,2 mm	1
21412	Ø 125 mm Ø 22,2 mm	1
21415	Ø 150 mm Ø 22,2 mm	1
21418	Ø 180 mm Ø 22,2 mm	1
21423	Ø 230 mm Ø 22,2 mm	1
21424	Ø 300 mm Ø 25,4 mm	1



FESTA

VOLLE DIAMANTSCHLEIBE



Nr.	Spezifikation	
21210	Ø 110 mm Ø 22,2 mm	1
21211	Ø 115 mm Ø 22,2 mm	1
21212	Ø 125 mm Ø 22,2 mm	1
21215	Ø 150 mm Ø 22,2 mm	1
21218	Ø 180 mm Ø 22,2 mm	1
21219	Ø 180 mm Ø 25,4 mm	1
21220	Ø 200 mm Ø 25,4 mm	1
21223	Ø 230 mm Ø 22,2 mm	1
21224	Ø 300 mm Ø 25,4 mm	1



FESTA INDUSTRY

DIAMANTTRENNSCHEIBE, UNIVERSSELL



Nr.	Spezifikation	
21301	Ø 125 mm Ø 22,2 mm 1,5 mm	1
21303	Ø 230 mm Ø 22,2 mm 1,8 mm	1



FESTA

DIAMANT-SEGMENTSCHLEIBE, DOPPELT



Nr.	Spezifikation	
21195	Ø 125 x 22,2 mm	1

6 mm

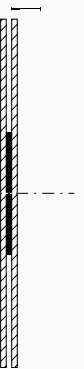

VOLLE DIAMANTSCHLEIBE



Nr.	Spezifikation	
21010	Ø 110 mm Ø 22,2 mm	1
21011	Ø 115 mm Ø 22,2 mm	1
21012	Ø 125 mm Ø 22,2 mm	1
21015	Ø 150 mm Ø 22,2 mm	1
21018	Ø 180 mm Ø 22,2 mm	1
21023	Ø 230 mm Ø 22,2 mm	1



VOLLDIAMANTSCHLEIBE



Nr.	Spezifikation	
21110	Ø 110 mm Ø 22,2 mm	1
21111	Ø 115 mm Ø 22,2 mm	1
21112	Ø 125 mm Ø 22,2 mm	1
21115	Ø 150 mm Ø 22,2 mm	1
21118	Ø 180 mm Ø 22,2 mm	1
21123	Ø 230 mm Ø 22,2 mm	1



TURBO-DIAMANTSCHLEIBE



Nr.	Spezifikation	
21130	Ø 110 mm Ø 22,2 mm	1
21135	Ø 115 mm Ø 22,2 mm	1
21140	Ø 125 mm Ø 22,2 mm	1
21150	Ø 150 mm Ø 22,2 mm	1
21180	Ø 180 mm Ø 22,2 mm	1
21190	Ø 230 mm Ø 22,2 mm	1



FESTA
DIAMANT
-SCHLEIFSCHEIBE



Nr.	Spezifikation		
21435	Ø 115 mm	Ø 22,2 mm	1
21436	Ø 125 mm	Ø 22,2 mm	1
21437	Ø 150 mm	Ø 22,2 mm	1



FESTA
DIAMANT
SCHLEIFSCHEIBE,
DOPPELT



Nr.	Spezifikation		
21430	Ø 115 mm	Ø 22,2 mm	1
21431	Ø 125 mm	Ø 22,2 mm	1
21432	Ø 150 mm	Ø 22,2 mm	1



FESTA
TURBO
-DIAMANT
SCHLEIFSCHEIBE



Nr.	Spezifikation		
21425	Ø 100 mm	Ø 22,2 mm	1
21426	Ø 115 mm	Ø 22,2 mm	1
21427	Ø 125 mm	Ø 22,2 mm	1
21428	Ø 150 mm	Ø 22,2 mm	1



FESTA
INDUSTRY
TRENNSCHEIBE
FÜR METALL



Nr.	Spezifikation		
22258	Ø 115 mm	Ø 22,2 mm x 0,8 mm	25
22260	Ø 115 mm	Ø 22,2 mm x 1 mm	25
22263	Ø 115 mm	Ø 22,2 mm x 1,6 mm	25
22264	Ø 115 mm	Ø 22,2 mm x 2 mm	25
22259	Ø 125 mm	Ø 22,2 mm x 0,8 mm	25
22266	Ø 125 mm	Ø 22,2 mm x 1 mm	25
22269	Ø 125 mm	Ø 22,2 mm x 1,6 mm	25
22270	Ø 125 mm	Ø 22,2 mm x 2 mm	25
22273	Ø 150 mm	Ø 22,2 mm x 1,6 mm	25
22274	Ø 150 mm	Ø 22,2 mm x 2 mm	25
22275	Ø 150 mm	Ø 22,2 mm x 2,5 mm	25
22277	Ø 180 mm	Ø 22,2 mm x 2 mm	25
22280	Ø 230 mm	Ø 22,2 mm x 2 mm	25
22281	Ø 230 mm	Ø 22,2 mm x 2,5 mm	25



FESTA
INDUSTRY
TRENNSCHEIBE
FÜR ALUMINIUM



Nr.	Spezifikation		
22285	Ø 115 mm	Ø 22,2 mm x 1 mm	1
22286	Ø 125 mm	Ø 22,2 mm x 1 mm	1



FESTA
INDUSTRY
TRENNSCHEIBE
FÜR STEIN



Nr.	Spezifikation		
22294	Ø 230 mm	Ø 22,2 mm x 3 mm	1

FESTA

TRENNSCHEIBE FÜR METALL



Nr.	Spezifikation	
22211	Ø 115 mm Ø 22,2 mm x 1 mm	INOX 50
22212	Ø 115 mm Ø 22,2 mm x 1,2 mm	INOX 50
22225	Ø 125 mm Ø 22,2 mm x 1 mm	INOX 50
22217	Ø 125 mm Ø 22,2 mm x 1,2 mm	INOX 50

FESTA

TRENNSCHEIBE FÜR METALL

10x



Nr.	Spezifikation	
22228	Ø 115 mm Ø 22,2 mm x 1 mm	INOX 1
22229	Ø 125 mm Ø 22,2 mm x 1,2 mm	INOX 1

FESTA

TRENNSCHEIBE FÜR METALL



Nr.	Spezifikation	
22251	Ø 115 mm Ø 22,2 mm x 1,6 mm	50
22215	Ø 115 mm Ø 22,2 mm x 2 mm	50
22216	Ø 115 mm Ø 22,2 mm x 2,5 mm	50
22252	Ø 125 mm Ø 22,2 mm x 1,6 mm	25
22218	Ø 125 mm Ø 22,2 mm x 2,5 mm	25
22219	Ø 150 mm Ø 22,2 mm x 1,2 mm	25
22253	Ø 150 mm Ø 22,2 mm x 1,6 mm	50
22220	Ø 150 mm Ø 22,2 mm x 2,5 mm	50
22254	Ø 180 mm Ø 22,2 mm x 1,6 mm	50
22222	Ø 180 mm Ø 22,2 mm x 2,5 mm	25
22255	Ø 230 mm Ø 22,2 mm x 1,6 mm	25
22224	Ø 230 mm Ø 22,2 mm x 2,5 mm	25

FESTA

TRENNSCHEIBE FÜR METALL



Nr.	Spezifikation	
22240	Ø 115 mm Ø 22,2 mm x 6,4 mm	25
22242	Ø 125 mm Ø 22,2 mm x 6,4 mm	25
22244	Ø 150 mm Ø 22,2 mm x 6,4 mm	25
22246	Ø 180 mm Ø 22,2 mm x 6,4 mm	25
22248	Ø 230 mm Ø 22,2 mm x 6,4 mm	25

FESTA

DIAMANTTRENNSCHEIBE FÜR METALL



Nr.	Spezifikation	
21306	Ø 125 mm Ø 22,2 mm 1,3 mm	1
21308	Ø 230 mm Ø 22,2 mm 1,8 mm	1

FESTA

TRENNSCHEIBE FÜR STEIN



Nr.	Spezifikation	
22230	Ø 115 mm Ø 22,2 mm x 2,5 mm	50
22232	Ø 125 mm Ø 22,2 mm x 2,5 mm	50
22234	Ø 150 mm Ø 22,2 mm x 2,5 mm	25
22236	Ø 180 mm Ø 22,2 mm x 2,5 mm	25
22238	Ø 230 mm Ø 22,2 mm x 2,5 mm	25

FESTA

KARBIDTRENNSCHEIBE, UNIVERSSELL



Nr.	Spezifikation	
21192	Ø 125 mm Ø 22,2 mm	1
21194	Ø 230 mm Ø 22,2 mm	1

FESTA
RASPELRAD

20 mm

Nr. Spezifikation
21806 Ø 125 mm Ø 22,2 mm 10

FESTA
RASPELSCHIBE MITTELGROB



Nr. Spezifikation
21802 Ø 125 mm Ø 22,2 mm 3 mm 10

FESTA
RASPELSCHIBE MITTELGROB



Nr. Spezifikation
21801 Ø 125 mm Ø 22,2 mm 3 mm 10

FESTA
SAGE / SPATCH DISC



Nr. Spezifikation
21803 Ø 125 mm Ø 22,2 mm 1

FESTA
RASPELSCHIBE

NEW



Nr. Spezifikation
21805 Ø 125 mm Ø 22,2 mm 1

FESTA
HOLZSCHEIBE MIT LÖCHERN

Schleifscheibe zum Schleifen von Holz geeignet



Nr. Spezifikation
21800 Ø 125 mm Ø 22,2 mm 1

FESTA
ZYLINDER RASPEL

M14



40 mm

Nr. Spezifikation
21807 Ø 30 mm / 60 mm 1

FESTA
KUGELRASPEL

M14



65 mm

Nr. Spezifikation
21808 Ø 30 mm / 105 mm 10

FESTA
TRENNSCHEIBE



Ø 125 x 22,2 mm
10000 RPM
15000 RPM
MAX 167 m/s

Nr. Spezifikation
21804 Ø 125 mm Ø 22,2 mm 14T 1

NEW



**HOLZ-
TRENN-
SCHEIBE**



Nr.	Spezifikation		
21809	Ø 125 mm x 4T	Ø 22,2 mm	1

NEW

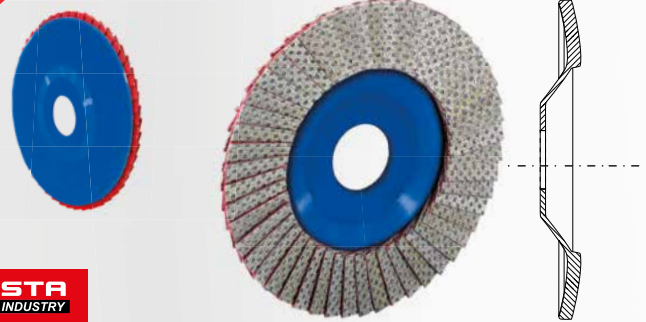

**FESTA
INDUSTRY**

**DIAMANT
FÄCHERSCHLEIFSCHEIBE**



- Keramikfliesen und -pflaster
- Marmor
- Granit



· Es ist keine Kühlung mit Wasser erforderlich

Nr.	Spezifikation			
24647	Ø 115 mm	Ø 22,2 mm	● P60	1
24648	Ø 115 mm	Ø 22,2 mm	● P120	1
24649	Ø 115 mm	Ø 22,2 mm	● P200	1

NEW



FESTA

**LAMELLEN-
SCHEIBE**



INOX

Nr.	Spezifikation	h grubost	
21760	Ø 125 mm Ø 22,2 mm	P40	10
21761	Ø 125 mm Ø 22,2 mm	P60	10
21762	Ø 125 mm Ø 22,2 mm	P80	10
21763	Ø 125 mm Ø 22,2 mm	P100	10
21764	Ø 125 mm Ø 22,2 mm	P120	10

FESTA

LAMELLENSCHEIBE

· Schleifscheibe geeignet zum Schleifen von Edelstahl



INOX

Nr.	Spezifikation	Grobheit	
22140	Ø 115 mm Ø 22,2 mm	P40	5
22141	Ø 115 mm Ø 22,2 mm	P60	5
22142	Ø 115 mm Ø 22,2 mm	P80	5
22143	Ø 115 mm Ø 22,2 mm	P100	5
22145	Ø 125 mm Ø 22,2 mm	P40	5
22146	Ø 125 mm Ø 22,2 mm	P60	5
22147	Ø 125 mm Ø 22,2 mm	P80	5
22148	Ø 125 mm Ø 22,2 mm	P100	5
22150	Ø 150 mm Ø 22,2 mm	P40	5
22151	Ø 150 mm Ø 22,2 mm	P60	5
22155	Ø 150 mm Ø 22,2 mm	P80	5
22156	Ø 150 mm Ø 22,2 mm	P100	5

LAMELLENSCHEIBE



Nr.	Spezifikation	Grobheit	
21780	Ø 115 mm Ø 22,2 mm	P40	10
21781	Ø 115 mm Ø 22,2 mm	P60	10
21782	Ø 115 mm Ø 22,2 m	P80	10
21783	Ø 115 mm Ø 22,2 mm	P100	10
21784	Ø 115 mm Ø 22,2 mm	P120	10
21786	Ø 125 mm Ø 22,2 mm	P40	10
21787	Ø 125 mm Ø 22,2 mm	P60	10
21788	Ø 125 mm Ø 22,2 mm	P80	10
21789	Ø 125 mm Ø 22,2 mm	P100	10
21790	Ø 125 mm Ø 22,2 mm	P120	10
21792	Ø 150 mm Ø 22,2 mm	P40	10
21793	Ø 150 mm Ø 22,2 mm	P60	10
21794	Ø 150 mm Ø 22,2 mm	P80	10
21795	Ø 150 mm Ø 22,2 mm	P100	10
21796	Ø 150 mm Ø 22,2 mm	P120	10

**UNIVERSAL-
SCHLEIFSCHEIBE**



NYLON
NORTON SAINT-GOBAIN
MADE IN EU **oSa**



Nr.	Spezifikation	
21798	Ø 125 mm Ø 22,2 mm	1

FESTA



FESTA
SCHALENBÜRSTE, GEWELLT
· vermessingt

M14

Nr.	Spezifikation	draht	
21900	Ø 100 mm M14	s 0,3	60
21902	Ø 125 mm M14	s 0,3	42



FESTA
SCHALENBÜRSTE, GEWELLT
· vermessingt

M14

Nr.	Spezifikation	draht	
22001	Ø 100 mm M14	s 0,3	60
21901	Ø 125 mm M14	s 0,3	42



FESTA
SCHALENBÜRSTE, GEWELLT
· aus Messing

M14

Nr.	Spezifikation	draht	
21920	Ø 100 mm M14	s 0,3	60



FESTA
TOPFBÜRSTE, GEWELLT
· vermessingt

M14

Nr.	Spezifikation	draht	
21903	Ø 65 mm M14	s 0,3	60
22002	Ø 75 mm M14	s 0,3	80
21904	Ø 85 mm M14	s 0,3	60
22003	Ø 100 mm M14	s 0,3	36
21905	Ø 125 mm M14	s 0,3	24
21906	Ø 150 mm M14	s 0,3	12



FESTA
TOPFBÜRSTE, GEWELLT
· aus Messing

M14

Nr.	Spezifikation	draht	
21925	Ø 75 mm M14	0,3 mm	80
21926	Ø 100 mm M14	0,3 mm	36



FESTA
RINGBÜRSTE, GEWELLT
· vermessingt
· Reduzierringe

M14

Nr.	Spezifikation	draht	
22007	Ø 100 mm Ø 20 mm	s 0,3	60
22008	Ø 125 mm Ø 20 mm	s 0,3	42
22009	Ø 150 mm Ø 32,2 mm	s 0,3	32
22010	Ø 175 mm Ø 32,2 mm	s 0,3	20
22011	Ø 200 mm Ø 32,2 mm	s 0,3	20



FESTA
TOPFBÜRSTE, ZÖPFE - EDELSTAHL
· patentiert

INOX M14

Nr.	Spezifikation	draht	
22037	Ø 65 mm M14	s 0,5	60
22038	Ø 80 mm M14	s 0,5	24



FESTA
TOPFBÜRSTE, ZÖPFE
· patentiert

M14

Nr.	Spezifikation	draht	
22004	Ø 65 mm M14	s 0,3	60
22005	Ø 75 mm M14	s 0,3	24
22006	Ø 100 mm M14	s 0,3	24
21907	Ø 125 mm M14	s 0,3	24
21908	Ø 150 mm M14	s 0,3	12



FESTA
RADIALE BÜRSTE, ZÖPFE
· patentiert

M14

Nr.	Spezifikation	draht	počet copů	
21911	Ø 100 mm M14	s 0,5	30	60
21912	Ø 115 mm M14	s 0,5	32	42
21913	Ø 125 mm M14	s 0,5	36	42
21914	Ø 150 mm M14	s 0,5	40	32



FESTA

RADIALE BÜRSTE, ZÖPFE

patentiert

M14



Nr.	Spezifikation	draht	
22012	Ø 100 mm M14	s 0,5	60
22013	Ø 115 mm M14	s 0,5	42
22014	Ø 125 mm M14	s 0,5	42
22015	Ø 150 mm M14	s 0,5	32
22016	Ø 178 mm M14	s 0,5	20



FESTA

RADIALE BÜRSTE, ZÖPFE

patentiert

INOX M14



Nr.	Spezifikation	draht	
22039	Ø 100 mm M14	s 0,5	60
22040	Ø 125 mm M14	s 0,5	42



FESTA

SCHALENBÜRSTE, ZÖPFE

patentiert

M14



Nr.	Spezifikation	draht	
22017	Ø 100 mm M14	s 0,5	60
21909	Ø 115 mm M14	s 0,5	42
21910	Ø 125 mm M14	s 0,5	42



FESTA

RINGBÜRSTE, ZÖPFE, SCHAFT

patentiert



Nr.	Spezifikation	draht	
22023	Ø 75 mm	s 0,5	10



FESTA

TOPFBÜRSTE, ZÖPFE, SCHAFT

patentiert



Nr.	Spezifikation	draht	
22024	Ø 75 mm	s 0,5	12



FESTA

SCHALENBÜRSTE, ZÖPFE, SCHAFT

patentiert



Nr.	Spezifikation	draht	
22025	Ø 75 mm	s 0,5	12

NEW



FESTA

RADIALE BÜRSTE, ZÖPFE



Nr.	Spezifikation	draht	
21950	Ø 200 mm 25,4 mm		1



FESTA

TOPFBÜRSTE, GEWELT, VERMESSINGT

vermessingt



Nr.	Spezifikation	draht	
22030	Ø 65 mm	s 0,3	12
22031	Ø 75 mm	s 0,3	12



FESTA

RINGBÜRSTE, GEWELT, VERMESSINGT

vermessingt



Nr.	Spezifikation	draht	
22026	Ø 50 mm	s 0,3	15
22027	Ø 63 mm	s 0,3	15
22028	Ø 75 mm	s 0,3	10
22029	Ø 100 mm	s 0,3	15



FESTA

ENDBÜRSTE, GEWELT, SCHAFT



Nr.	Spezifikation	draht	
22058	Ø 12 mm	s 0,3	25
22059	Ø 25 mm	s 0,3	25



FESTA

ENDBÜRSTE, GEWELT, VERMESSINGT

vermessingt



Nr.	Spezifikation	draht	
22018	Ø 12 mm	s 0,3	15
22019	Ø 17 mm	s 0,3	15
22020	Ø 25 mm	s 0,3	25



FESTA

ENDBÜRSTE, ZÖPFE, SCHAFT

patentiert



Nr.	Spezifikation	draht	
22021	Ø 19 mm	s 0,5	30
22022	Ø 22 mm	s 0,5	25



FESTA

TOPFBÜRSTE, GEWELLT, AUS NYLON

Nr.	Spezifikation	draht	
21940	Ø 75 mm M14	1,2 mm	1
21941	Ø 100 mm M14	1,2 mm	1



FESTA

RINGBÜRSTE, AUS NYLON

Nr.	Spezifikation	draht	
21930	Ø 125 mm M14	1,2 mm	10
21931	Ø 150 mm M14	1,2 mm	15

Ø 6 mm



FESTA

RINGBÜRSTE, AUS NYLON, SCHAFT

Nr.	Spezifikation	draht	
22032	Ø 100 mm	1,2 mm	12

Ø 6 mm



FESTA

RINGBÜRSTE, AUS NYLON, SCHAFT

Nr.	Spezifikation	draht	
21935	Ø 50 mm	1,2 mm	1
21936	Ø 75 mm	1,2 mm	1
21937	Ø 100 mm	1,2 mm	1



Ø 6 mm

NYLONSCHEIBE, SCHAFT

Nr.	Spezifikation	
22088	Ø 65 mm	9
22090	Ø 100 mm	5



NYLONBÜRSTE

Nr.	Spezifikation	
22083	Ø 115 mm Ø 22,2 mm	10
22084	Ø 125 mm Ø 22,2 mm	10
22085	Ø 150 mm Ø 22,2 mm	10



NYLONSCHEIBE

Nr.	Spezifikation	
22095	Ø 178 mm	1

NEW

FESTA

DIAMANT-SCHLEIFSCHEIBE MIT KLETTVERSCHLUSS

- Keramikfliesen
- Glas
- Marmor
- Granit



· mitnehmer 22043

Nr.	Spezifikation	Grobheit	
24665	Ø 100 mm	● P60	10
24666	Ø 100 mm	● P120	10
24667	Ø 100 mm	● P200	10

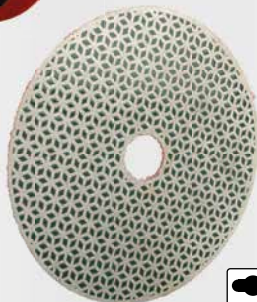

FESTA

DIAMANT-POLIERSCHEIBE Ø 100 MM, MIT KLETTVERSCHLUSS

- Keramikfliesen
- Glas
- Marmor
- Granit



· mitnehmer 22043

Nr.	Grobheit	
22701	50	1
22702	100	1
22703	200	1
22704	400	1
22705	800	1
22706	1500	1
22707	3000	1





POLIERSCHEIBE, LAMM

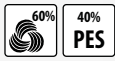

Nr.	Spezifikation	Spezifikation	
22065	Ø 125 mm	mit Klettverschluss	20
22066	Ø 150 mm	mit Klettverschluss	20

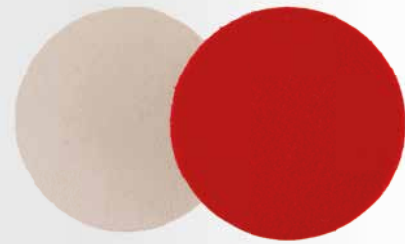

POLIERFILZ MIT KLETTVERSCHLUSS



Nr.	Spezifikation	
22070	Ø 115 mm	20
22071	Ø 125 mm mit Klettverschluss	20
22072	Ø 150 mm	20

FESTA

SCHLEIFPAPIER MITNEHMER MIT KLETTVERSCHLUSS

- M14 | Ø 8 mm
- EVA 10 mm

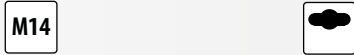

Nr.	Spezifikation	
22062	Ø 115 mm	25
22063	Ø 125 mm	25
22064	Ø 150 mm	10



FESTA

MITNEHMER FÜR FIBER-ROLLE



Nr.	Spezifikation	
22073	Ø 125 mm, M14	1
22074	Ø 150 mm, M14	1



FESTA

MITNEHMER VON DIAMANTPOLIERSCHEIBEN

- für Winkelschleifer
- für 24665-24667, 22701-22707

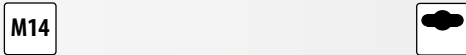

Nr.	Spezifikation	
22043	Ø 100 mm mit Klettverschluss	1



SCHLEIFPAPIER MITNEHMER

- für Winkelschleifer

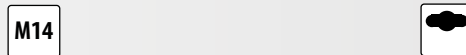

Nr.	Spezifikation	
22044	Ø 125 mm M14 mit Klettverschluss	15
22060	Ø 150 mm M14 mit Klettverschluss	6



ADAPTER



Nr.	Spezifikation	
22087		1



SCHLEIFSCHEIBE, AUS NYLON



Nr.	Spezifikation	
22091	Ø 50 mm P240	1
22092	Ø 75 mm P240	1
22093	Ø 100 mm P240	1

GELENKIGER SCHLEIFPAPIER MITNEHMER

Nr.	Spezifikation	
22061	Ø 125 mm mit Klettverschluss	6

SCHLEIFPAPIER-MITNEHMER

Nr.	Spezifikation	
22041	Ø 125 mm Schraubbefestigung	11
22042	Ø 125 mm mit Klettverschluss	11

FESTA

FIBERSCHEIBE - Ø 125 MM



Nr.	Grobheit	
22160	P40	1
22161	P60	1
22162	P80	1
22163	P100	1
22164	P120	1



FESTA

FIBERSCHEIBE - Ø 150 MM



Nr.	Grobheit	
22167	P80	1



FESTA

SCHLEIFPAPIER Ø 125 MM, MIT KLETTVERSCHLUSS

3x

Nr.	Grobheit	
22045	P40	1
22046	P60	1
22047	P80	1
22048	P100	1
22049	P120	1
22050	P150	1
22051	P180	1
22052	P220	1

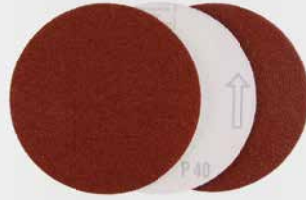

FESTA

SCHLEIFPAPIER Ø 150 MM, MIT KLETTVERSCHLUSS

3x

Nr.	Grobheit	
22053	P40	1
22054	P60	1
22055	P80	1
22056	P100	1
22057	P120	1

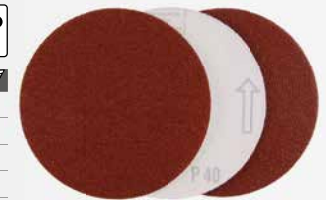

FESTA

VIBRATIONSAUSSCHNITT 94 X 94 X 94 MM

Nr.	Grobheit	
21831	P60	1
21832	P80	1
21834	P120	1

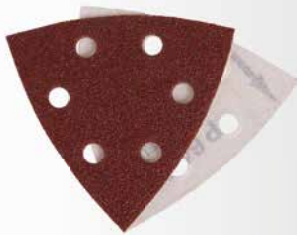

SCHLEIFPAPIER MIT KLETTVERSCHLUSS - 125 MM

Nr.	Grobheit	
22096	P40	20
22097	P60	20
22098	P80	20
22099	P120	20



FESTA

ENDLOSES SCHLEIFBAND - 75 X 533 MM

Nr.	Grobheit	
21810	P40	20
21811	P60	20
21812	P80	20
21813	P100	20
21814	P120	20



SCHLEIFPAPIER 93 X 230 MM

5x

Nr.	Grobheit	Lochanzahl	
21740	P40	8	20
21741	P60	8	20
21742	P80	8	20
21743	P100	8	20
21744	P120	8	20



SCHLEIFPAPIER 115 X 280 MM

5x

Nr.	Grobheit	Lochanzahl	
21750	P40	10	20
21751	P60	10	20
21752	P80	10	20
21753	P100	10	20
21754	P120	10	20



SCHLEIFLEINEN 230 X 280 MM

10x

Nr.	Grobheit	
21732	P40	1
21734	P60	1
21735	P80	1
21736	P100	1
21737	P120	1

SCHLEIFPAPIER, WASSERFEST 230 X 280 MM

10x

Nr.	Grobheit	
21701	P60	1
21702	P80	1
21703	P100	1
21704	P120	1
21705	P150	1
21706	P180	1
21709	P240	1

SCHLEIFPAPIER 230 X 280 MM

10x

Nr.	Grobheit	
21715	P40	1
21716	P60	1
21717	P80	1
21718	P100	1
21719	P120	1
21720	P150	1
21721	P180	1
21724	P240	1



NEW



FESTA

HALTER
DES SCHLEIFPAPIERS

· Ø 150 mm



Nr.	Spezifikation	
22119		1

FESTA

HALTER
DES SCHLEIFPAPIERS

· schnellspannend
· Buchenholzgriff



Nr.	Spezifikation	
22067	170 x 70 mm	10

HALTER
DES SCHLEIFPAPIERS



Nr.	Spezifikation	
22075	210 x 105 mm	100
22076	160 x 85 mm	100

HALTER
DES SCHLEIFPAPIERS



Nr.	Spezifikation	
22077	125 x 68 mm	10

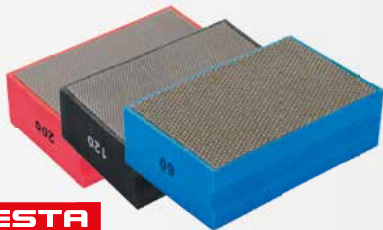

FESTA

DIAMANTSCHLEIFSWAMM

- 90 x 55 x 25 mm
- Keramikverkleidungen
- Glas
- Marmor
- Granit



Nr.	Grobheit	
22115	P60	10
22116	P120	10
22117	P200	10

SCHLEIFLAMELLENSCHEIBE
AM SCHAFT

Nr.	Grobheit	Spezifikation	
21850	P40		1
21851	P60		1
21852	P80	20 x 20, Ø 6 mm	1
21853	P100		1
21854	P120		1
21855	P40		1
21856	P60		1
21857	P80	30x30, Ø 6mm	1
21858	P100		1
21859	P120		1
21860	P40		1
21861	P60		1
21862	P80	60x30, Ø 6mm	1
21863	P100		1
21864	P120		1



FESTA

SCHLEIFSWAMM 100 X 70 X 28 MM,
ABGESCHRÄGT



Nr.	Grobheit	
22106	P 60	10
22107	P 80	10
22108	P 100	10
22109	P 120	10



FESTA

SCHLEIFSWAMM
100 X 70 X 25 MM



Nr.	Grobheit	
22100	P60	20
22101	P80	20
22102	P100	20
22103	P120	20
22104	P180	20
22105	P220	20



FESTA

SCHLEIFSWAMM
120 X 95 X 10 MM



Nr.	Grobheit	
22110	P80	20
22111	P120	20
22112	P180	20
22113	P220	20

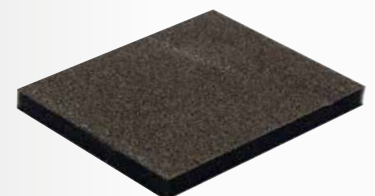

FESTA



Nr.	Spezifikation	Anzahl der Zähne	
Ø 115 mm			
22300	Ø 115 x 22 mm	40	1
Ø 125 mm			
22301	Ø 125 x 22 mm	40	1
Ø 140 mm			
22302	Ø 140 x 20 mm	24	1
22303	Ø 140 x 20 mm	30	1
Ø 150 mm			
22305	Ø 150 x 20 mm	24	1
Ø 160 mm			
22307	Ø 160 x 20 mm	18	1
22309	Ø 160 x 20 mm	24	1
22310	Ø 160 x 20 mm	30	1
22311	Ø 160 x 20 mm	36	1
22312	Ø 160 x 20 mm	48	1
22313	Ø 160 x 20 mm	60	1
Ø 165 mm			
22314	Ø 165 x 20 mm	24	1
Ø 180 mm			
22315	Ø 180 x 30 mm	24	1
22317	Ø 180 x 30 mm	50	1
22318	Ø 180 x 20 mm	50	1
Ø 185 mm			
22316	Ø 185 x 20 mm	24	1
Ø 190 mm			
22319	Ø 190 x 20 mm	40	1
22320	Ø 190 x 30 mm	40	1
Ø 200 mm			
22322	Ø 200 x 30 mm	24	1
22324	Ø 200 x 30 mm	40	1
22326	Ø 200 x 30 mm	60	1
Ø 205 mm			
22328	Ø 205 x 30 mm	40	1
22329	Ø 205 x 30 mm	60	1
Ø 210 mm			
22332	Ø 210 x 30 mm	40	1
22333	Ø 210 x 30 mm	60	1
Ø 250 mm			
22335	Ø 250 x 30 mm	40	1
22337	Ø 250 x 30 mm	60	1
Ø 300 mm			
22340	Ø 300 x 30 mm	40	1
22343	Ø 300 x 30 mm	60	1
22345	Ø 300 x 30 mm	96	1
Ø 350 mm			
22350	Ø 350 x 30 mm	40	1
22351	Ø 350 x 30 mm	54	1
Ø 400 mm			
22355	Ø 400 x 30 mm	40	1
22357	Ø 400 x 30 mm	60	1
Ø 500 mm			
22365	Ø 500 x 30 mm	60	1
Ø 600 mm			
22370	Ø 600 x 30 mm	60	1



FESTA

SÄGEBLATT FÜR HOLZ MIT SK-SCHEIBEN

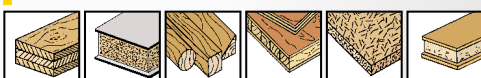

REDUZIERRING

Nr.	Spezifikation	
22399	Ø 20 16 mm	1
22398	Ø 30 25 mm	1

FESTA

ZUBEHÖRSET FÜR OSZILLIERENDE MULTIFUNKTIONSWERKZEUGE

für 28045



4x

3x BI-METAL



1x SK5

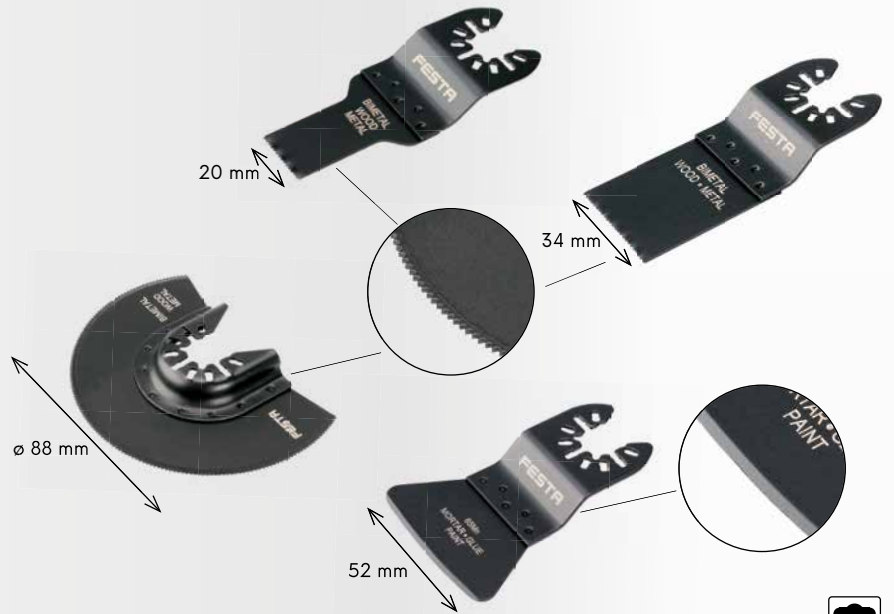

Nr. Spezifikation

24322

6

FESTA

ZUBEHÖRSET FÜR OSZILLIERENDE MULTIFUNKTIONSWERKZEUGE

für 28045



4x

3x HARTMETALL



1x

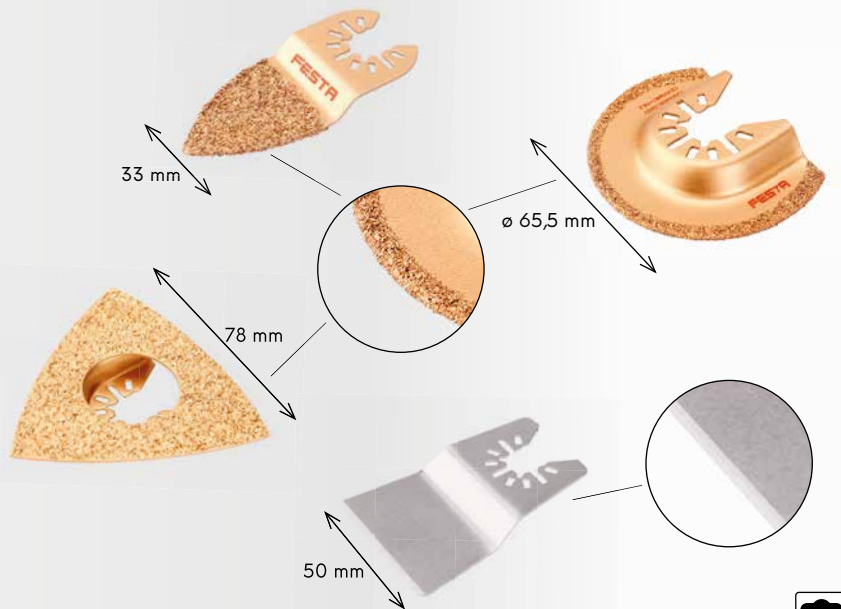

Nr. Spezifikation

24321

6

ZUBEHÖRSET FÜR OSZILLIERENDE MULTIFUNKTIONSWERKZEUGE

für 28045



HCS 3x

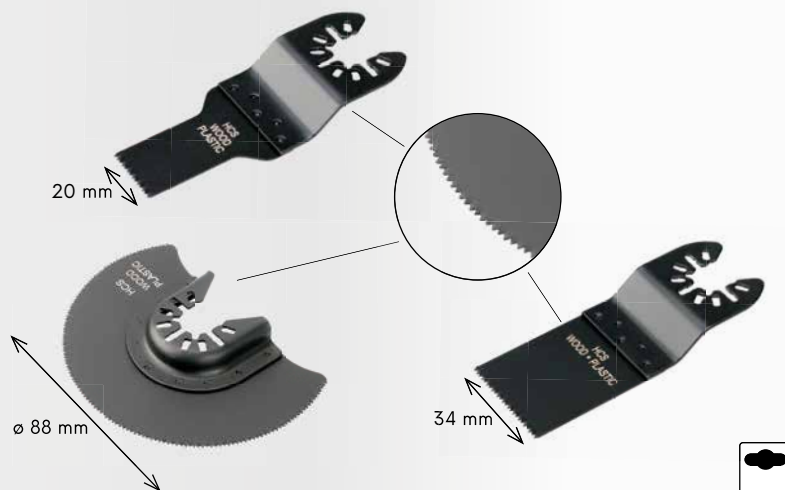

Nr. Spezifikation

24320

6

PROFI-GERADSÄGEN
HERGESTELLT IN DEUTSCHLAND MIT LASERBRENNTHEKNOLOGIE



HSS-GERADSÄGE - BEFESTIGUNG AEG, BOSCH, FESTO, MAKITA, METABO

	24060	50mm/1mm	0,7 mm/ 36TPI	31007	5 Stck	10	
	24061	50mm/1mm	1,2 mm/ 21TPI	31012	5 Stck	10	
	24062	50mm/1mm	2,0 mm/ 13TPI	31020	5 Stck	10	
	24063	75mm/1mm	3,0 mm/ 8TPI	31030	5 Stck	10	
	24064	100mm/1mm	1,2 mm/ 21TPI	31112	5 Stck	10	
	24065	100mm/1,3mm	2,0 mm/ 13TPI	31112	5 Stck	10	
	24066	75mm/1,45mm	2,0 mm/ 13TPI	31220	5 Stck	10	
	24067	120mm/1,3mm	1,8 - 2,4 mm/ 10 - 14 TPI	31220	5 Stck	10	
	24068	75mm/1,45mm	2,5 mm/ 10 TPI	32225	5 Stck	10	
	24069	75mm/1,45mm	4 mm/ 6 TPI	32240	5 Stck	10	
	24070	75mm/1,3mm	4 mm/ 6 TPI	32340	5 Stck	10	
	24071	75mm/1,3mm	4 mm/ 6 TPI	32440	5 Stck	10	
	24072	75mm/1,45mm	2,5 mm/ 10 TPI	32625	5 Stck	10	
	24073	85mm/1,45mm	3 mm/ 8 TPI	32730	5 Stck	10	
	24074	85mm/1,45mm	4 mm/ 6 TPI	32730	5 Stck	10	
	32825	75mm/1,45mm	2,5 1,2 mm/10 21 TPI	32825	5 Stck	10	
	24076	75mm/1,7mm	4 mm 6 TPI	32940	5 Stck	10	
	24077	120mm/1,3mm	4 mm 6 TPI	32040	5 Stck	10	
	24078	105mm/1,45mm	4 mm 6 TPI	34040	5 Stck	10	
	24055	55mm	Karbid		5 Stck	1	

HSS-GERADSÄGE - BEFESTIGUNG BLACK & DECKER, FERM

	24080	50mm 1,0 mm	1,2 21 TPI	11012	5 Stck	10	
	24081	75mm 1,0 mm	3,0 8 TPI	11030	5 Stck	10	
	24082	75mm 1,45 mm	2,5 10 TPI	12225	5 Stck	10	
	24083	75mm 1,45 mm	4 6 TPI	12240	5 Stck	10	
	24084	75mm 1,3 mm	4 6 TPI	12340	5 Stck	10	
	24085	50mm 1,0 mm	2,0 13 TPI	12420	5 Stck	10	
	24086	75mm 1,3 mm	4,0 6 TP	12440	5 Stck	10	
	24087	75mm 1,45 mm	2,5 10 TPI	12625	5 Stck	10	

	Weichstahl (mit niedrigem Kohlenstoff- gehalt)		Stahlblech		Edelstahl		laminierte Bretter
	NE-Metalle		Hartholz und Weichholz		Spannplatte		Kunststoffe
	Sperrholz		Lattensperholz		Holz mit Nägel		
	Sandwichmaterialien		Pflaster und Fliesen		Alu		

GRADSÄGEN- STÄNDER

- Montage des Ständers - 24060 · 5 Stck
- 24080 · 5 Stck
- 24061 · 5 Stck
- 24062 · 5 Stck
- 24081 · 5 Stck
- 24063 · 5 Stck
- 24066 · 5 Stck
- 24067 · 5 Stck
- 24082 · 5 Stck
- 24068 · 5 Stck
- 24083 · 5 Stck
- 24069 · 5 Stck
- 24084 · 5 Stck
- 24070 · 5 Stck
- 24086 · 5 Stck
- 24071 · 5 Stck
- 24087 · 5 Stck
- 24072 · 5 Stck
- 24073 · 5 Stck
- 24074 · 5 Stck
- 24075 · 5 Stck
- 24076 · 5 Stck



GRADSÄGEN-SET



5x

Nr.	Spezifikation	
24045	Set	50

Nr.	Spezifikation	
24099	64 x 50 cm - leer	1
24098	64 x 50 cm - montiert	1

FESTA

SÄGEBLATT

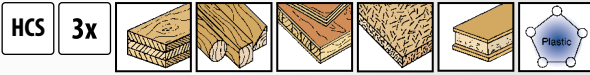

Nr. 24301 Spezifikation 150 x 19 x 1,3 mm TPI 6



1

FESTA

SÄGEBLATT

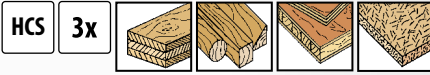

Nr. 24302 Spezifikation 225 x 19 x 1,3 mm TPI 3



1

FESTA

SÄGEBLATT

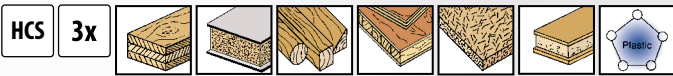

Nr. 24303 Spezifikation 200 x 19 x 1,3 mm TPI 6 - 10



1

FESTA

SÄGEBLATT

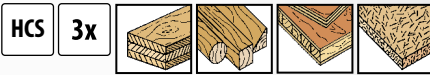

Nr. 24304 Spezifikation 240 x 19 x 1,5 mm TPI 5



1

FESTA

SÄGEBLATT

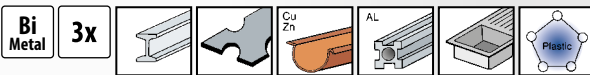

Nr. 24305 Spezifikation 150 x 19 x 1 mm TPI 24

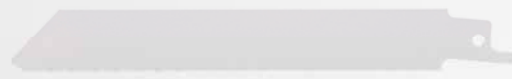

1

FESTA

SÄGEBLATT

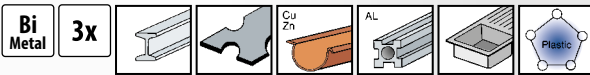

Nr. 24306 Spezifikation 150 x 19 x 1 mm TPI 9



1

FESTA

SÄGEBLATT



Nr. 24308 Spezifikation 225 x 19 x 1 mm TPI 10 - 14

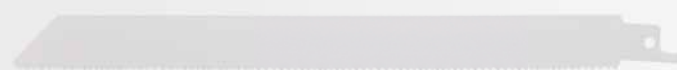

1

FESTA

SÄGEBLATT



Nr. 24310 Spezifikation 150 x 22 x 1,6 mm TPI 9



1

FESTA

SÄGEBLATT



Nr.	Spezifikation	
24313	225 x 22 x 1,6 mm TPI 6	1

FESTA

HSS-METALL-SÄGE

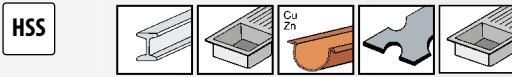

Nr.	Spezifikation	
24050	203 x 19 x 1 mm TPI 10 - 14	25

FESTA

SÄGEBLATT

· SK zuby, dlouhá životnost

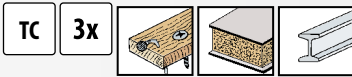

Nr.	Spezifikation	
24312	225 x 19 x 1,3 mm TPI 6 - 9	1

FESTA

SÄGEBLATT



Nr.	Spezifikation	
24315	305 x 50 x 1,5 mm	1
24316	455 x 50 x 1,5 mm	25

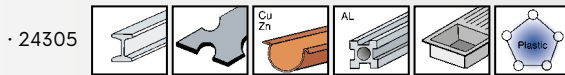
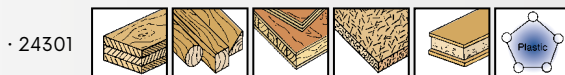

FESTA

SÄGEBLÄTTER-SET



Nr.	Spezifikation	
24314		1



FESTA

GRIF FÜR SÄGEBLÄTTER

· Griff + 2x Sägeblatt für Säbelsägeblätter



Nr.	Spezifikation	
24325		1





FESTA
INDUSTRY



SÄGEBLATT

· gehärtete Zähne



Nr.	Spezifikation	
24185	533 mm	1
24186	610 mm	1
24187	760 mm	1
24188	800 mm	1
24189	914 mm	1

FESTA

SÄGEBLATT

· gehärtete Zähne



Nr.	Spezifikation	
24169	350 mm	10
24167	450 mm	10
24166	533 mm	10
24163	610 mm	10
24164	760 mm	10
24168	800 mm	10
24165	914 mm	10



SÄGEBLATT



Nr.	Spezifikation	
24195	Teilung 3 mm 300 mm	1
24196	Teilung 4 mm 300 mm Kegeltzahn	1
24197	Teilung 5 mm 300 mm gehärteter Zahn	1
24192	Fleischersägeblatt 450 mm	1

SÄGEBLATT



Nr.	Spezifikation	
24160	Teilung 3 mm 300 mm	20
24161	Teilung 4 mm 300 mm	20
24162	Teilung 5 mm 300 mm	50

SÄGEBLATT

10x



Nr.	Spezifikation	
24108	6 mm 150 mm	1

SCHNEIDSAITE



Nr.	Spezifikation	
24120	300 mm	50



FESTA

BIMETALL-SÄGEBLATT

· 8 % COBALT



Nr.	Spezifikation	
24180	300 mm	125

FESTA

SÄGEBLATT



Nr.	Spezifikation	
24109	12,5 mm 300 mm für Metall	144
24118	25 mm 300 mm für Metall beidseitig	72
24119	25 mm 300 mm für Metall und Holz	72





96

MASSBÄNDER



101

FALTMETER



104

LINEALE UND
WINKELMESSER

106

WASSERWAAGEN UND
LATTEN

112

LASERMESSGERÄT



116

BLEISTIFTE UND MARKER



120

SPRAYS



122

ABBRECHMESSER



137

SCHWEISSER, SCHNEIDER,
ZANGEN FÜR PVC-ROHRE

140

SCHRAUBENDREHER



146

BITS



154

GOLA-SETS UND
RATSCHEN

159

KÖPFE, AUFSÄTZE,
ADAPTER

164

SCHLÜSSEL



169

ZANGE



179

BLECHSCHERE,
TECHNISCHE SCHERE

182

NIETZANGE



188

FEILE UND RASPEL



190

SÄGEN FÜR HOLZ, METALL
UND ANDERE

195

HÄMMER UND KLÖPPEL



203

KLEMMEN

94 - 205



KOMELON®

· HOCHPRÄZISE QUALITÄTSMESSGERÄTE

- II. Präzisionsklasse gemäß ČSN 251104, EEC 755345
- Die Nylon-Oberfläche des DURA NY Coat™-Bandes garantiert eine zehnfach höhere Abriebfestigkeit der Skala

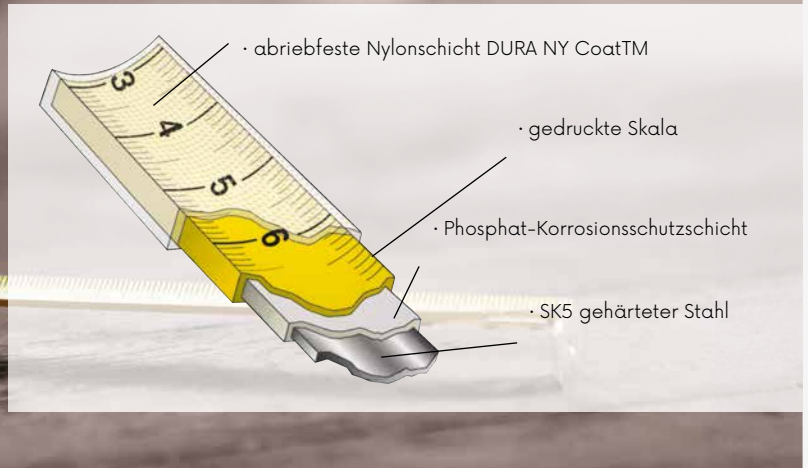

· Abriebfeste Schicht aus Nylon DURA NY Coat™



· Abriebfeste Schicht aus Nylon DURA NY Coat™



· Abriebfeste Schicht aus Nylon DURA NY Coat™

KOMELON® ROLLMASSBAND



Nr.	Spezifikation	
10002	2 m · 16 mm	10
10003	3 m · 16 mm	10
10005	5 m · 19 mm	10
10008	8 m · 25 mm	10

KOMELON® ROLLMASSBAND



Nr.	Spezifikation	
10025	5 m · 25 mm	10

KOMELON® ROLLMASSBAND

- automatische Bremse
- rutschhemmende Gummibeschichtung

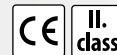

Nr.	Spezifikation	
10033	3 m · 16 mm	6
10035	5 m · 19 mm	6



KOMELON® ROLLMASSBAND



Nr.	Spezifikation	
10043	3 m · 16 mm	30
10045	5 m · 19 mm	30
10048	8 m · 25 mm	12



KOMELON® STAHLBAND



Nr.	Spezifikation	
10110	10 m · 10 mm	6
10120	20 m · 10 mm	6
10130	30 m · 10 mm	6



KOMELON® GLASFASERBAND



Nr.	Spezifikation	
10330	10 m · 13 mm	6
10332	20 m · 13 mm	6
10334	30 m · 13 mm	6
10336	50 m · 13 mm	6



KOMELON®
GLASFASERBAND



Nr.	Spezifikation	
10430	30 m · 13 mm	1
10450	50 m · 13 mm	1
10490	100 m · 13 mm	1



· Beispielfoto

MASSBANDSTÄNDER

Nr.	Spezifikation	
10998		1

KOMELON®
MASSBANDSTÄNDER

· Montage des Ständers 10996

- 10003 · 5 ks
- 10005 · 4 ks
- 10008 · 1 ks
- 10033 · 2 ks
- 10035 · 3 ks
- 10045 · 2 ks
- 10025 · 3 ks
- 10110 · 1 ks
- 10120 · 1 ks
- 10130 · 1 ks
- 10430 · 1 ks
- 10330 · 1 ks
- 10332 · 1 ks
- 10334 · 1 ks
- 10336 · 1 ks



· Beispielfoto

Nr.	Spezifikation	
10999	Massbandständer	1
10996	Verkaufsständer für Maßbänder, gefüllt	1



· Informationen zum Massband



- A** · 5m · Massbandlänge
- B** · · Präzisionsklasse
- C** · · CE-Konformitätserklärung
- D** · · Baujahr
- E** · · Nummer der akkreditierten Prüfstelle, das Zertifikat ausstellt
- F** · · Hersteller
- G** · · Spezialbehandlung des Bandes
- H** · · die Temperatur, bei der der Test durchgeführt wurde durchgeführt

FESTA



FESTA

ROLLMASSBAND

- Skala mit großen Zahlen
- rutschhemmende Gummibeschichtung
- Nylonschicht



Nr.	Spezifikation	
11353	3 m · 19 mm	12
11355	5 m · 19 mm	12
11356	5 m · 25 mm	12
11358	8 m · 25 mm	6
11360	10 m · 25 mm	6



FESTA

ROLLMASSBAND

- Nylonschicht
- ABS-Gehäuse
- Metallclip, verchromt
- automatische Bremse
- rutschhemmende PTE-Gummibeschichtung
- Befestigungsschleufe



Nr.	Spezifikation	
11343	3 m · 16 mm	6
11345	5 m · 19 mm	6
11347	7,5 m · 25 mm	6



FESTA

MASSBAND - MAGNET

- 3 x Bremse
- Magnethaken
- Abbremsen
- rutschhemmende Gummibeschichtung

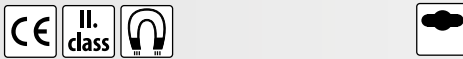

Nr.	Spezifikation	
11323	3 m · 19 mm	10
11325	5 m · 25 mm	10
11327	7,5 m · 25 mm	6



FESTA

MAGNETIC ROLLMASSBAND

- Magnethaken
- rutschhemmende Gummibeschichtung
- fluoreszierendes Band
- Skala mit großen Zahlen

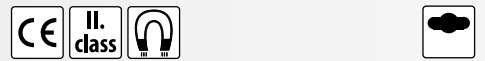

Nr.	Spezifikation	
11102	2 m · 16 mm	10
11103	3 m · 16 mm	10
11105	5 m · 19 mm	12
11106	5 m · 25 mm	12
11107	7,5 m · 25 mm	10
11110	10 m · 25 mm	6



FESTA

ROLLMASSBAND

- Skala mit großen Zahlen



Nr.	Spezifikation	
11226	2 m · 16 mm	10
11239	3 m · 19 mm	10
11259	5 m · 19 mm	12
11260	7,5 m · 25 mm	6



FESTA

ROLLMASSBAND

- automatische Bremse
- rutschhemmende Gummibeschichtung

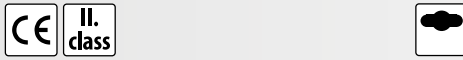

Nr.	Spezifikation	
11333	3 m · 16 mm	12
11335	5 m · 19 mm	12
11337	7,5 m · 25 mm	6
11338	10 m · 25 mm	6



FESTA

COMPACT - ROLLMASSBAND

- kleine Größe des Massbandes
- Nylonschicht

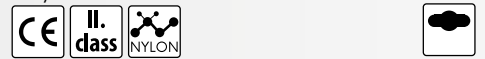

Nr.	Spezifikation	
11220	3 m · 16 mm	12
11221	5 m · 19 mm	12



Johnney®

ROLLMASSBAND

· matte Oberfläche des Bandes

II. class



Nr.	Spezifikation	
11002	2 m · 13 mm	12
11003	3 m · 13 mm	12
11005	5 m · 13 mm	12
11006	5 m · 19 mm	12
11007	7,5 m · 19 mm	12
11008	10 m · 25 mm	12



METR SVINOVACÍ - ERGO

· Abbremsen
· rutschhemmende Gummibeschichtung



Nr.	Spezifikation	
11082	2 m · 16 mm	12
11083	3 m · 16 mm	12
11085	5 m · 19 mm	12



ROLLMASSBAND

· metrische und Zoll-Skalierung
· rutschhemmende Gummibeschichtung



Nr.	Spezifikation	
11416	5 m · 19 mm	10



ROLLMASSBAND

· Abbremsen



Nr.	Spezifikation	
11200	2 m · 13 mm	24
11201	2 m · 16 mm	24
11202	2 m · 19 mm	24
11204	3 m · 13 mm	24
11205	3 m · 16 mm	24
11206	3 m · 19 mm	24
11207	5 m · 19 mm	12
11208	5 m · 25 mm	12
11209	7,5 m · 25 mm	12
11210	10 m · 25 mm	12

MASSBAND MIT NAMEN, 3M · 16 MM

CE II. class

Č.p.	jméno na metru	Č.p.	jméno na metru	Č.p.	jméno na metru	Č.p.	jméno na metru
13500	JIŘÍ	13509	MIROSLAV	13518	VÁCLAV	13527	MISTR
13501	PETR	13510	BIG BOSS	13519	JAKUB	13528	ONDŘEJ
13502	JOSEF	13511	ZDENĚK	13520	LUKÁŠ	13529	MAREK
13503	TOMÁŠ	13512	MICHAL	13521	2X MĚŘ	13530	STANISLAV
13504	JAN	13513	MILAN	13522	LADISLAV	13531	BOREC
13505	MARTIN	13514	KAREL	13523	DAVID	13532	TATÍNEK
13506	JAROSLAV	13515	VLADIMÍR	13524	ROMAN	13533	ANTONÍN
13507	FRANTIŠEK	13516	DĚDEČEK	13525	ŠIKULA	13534	ALEŠ
13508	PAVEL	13517	MŮJ METR	13526	RADEK		



10



FESTA

MASSBAND AUS STAHL

· Öse

CE II. class



Nr.	Spezifikation	
12010	10 m · 10 mm	1
12020	20 m · 10 mm	1
12030	30 m · 10 mm	1
12050	50 m · 10 mm	6



FESTA

GLASFASERBAND

· Öse

CE II. class



Nr.	Spezifikation	
12110	10 m · 13 mm	6
12120	20 m · 13 mm	1
12130	30 m · 13 mm	1
12150	50 m · 13 mm	1



FESTA

STAHLBAND

· Öse + Haken

CE II. class



Nr.	Spezifikation	
12220	20 m · 10 mm	6
12230	30 m · 10 mm	6
12250	50 m · 10 mm	6



FESTA

STAHLBAND

· Öse



Nr.	Spezifikation	
12433	30 m · 12,5 mm	20
12435	50 m · 12,5 mm	10



MESSRAD

- Beständig, leicht und kompakt
- Der Zähler addiert beim Vorwärtsbewegen und subtrahiert beim Rückwärtsbewegen
- Eingebaute Beleuchtung für Nacharbeit, 2 AAA-Batterien im Handgriff
- mit Etui



Nr.	Spezifikation	
15989	max. 10 km	2



FESTA

TELESKOPISCHE MESSSTANGE

· mit Etui

Nr.	Spezifikation	
15983	0,7 - 3 m	10
15985	1,1 - 5 m	10
15988	1,6 - 8 m	5



METALL-, MESS-, FLACH-, SELBSTKLEBEBAND



Nr.	Spezifikation	
11311	1 m · 12,5 mm	30
11312	2 m · 12,5 mm	30
11313	3 m · 16 mm	30
11314	5 m · 19 mm	30



MASSBAND ANHÄNGER

Nr.	Spezifikation	
11420	1 m · 6 mm orange	24



FESTA

MASSBAND ANHÄNGER

- Skala mit großen Zahlen
- Eigenschaften eines vollwertigen Massbandes



Nr.	Spezifikation	
11410	2 m · 16 mm 6 Farben	12



MASSBAND ANHÄNGER

Nr.	Spezifikation	
11444	1 m · 6 mm weiß	20



MASSBAND ANHÄNGER

Nr.	Spezifikation	
11425	1 m · 6 mm	25



LIBELLE - ANHÄNGER

Nr.	Spezifikation	
11445		100

FALTMETER



Nr.	Spezifikation	
13010	1 m · weiß	20
13020	2 m · weiß	10
13021	1 m · gelb	20
13022	2 m · gelb	10
13023	2 m · weiß - gelb	10

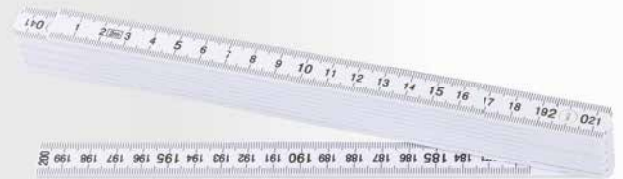
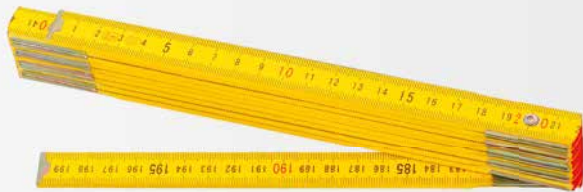
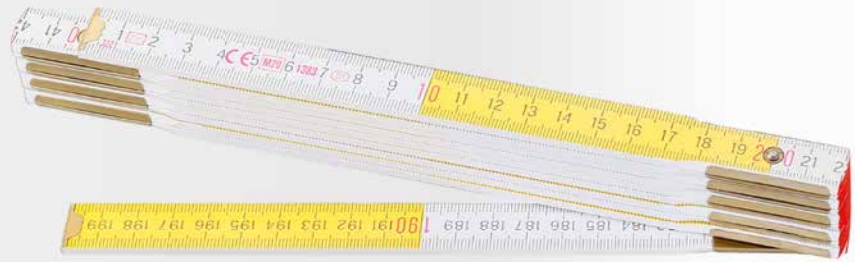

FALTMETER



Nr.	Spezifikation	
13111	1 m · gelb	10
13120	2 m · gelb	5

FALTMETER



Nr.	Spezifikation	
13211	1 m	1
13220	2 m	1



FALTMETER MIT NAMEN



Nr.	Name auf dem Maßband	Nr.	Name auf dem Maßband		
13401	JIRÍ	13426	DANIEL	10	
13402	JAN	13427	ANTONÍN		
13403	PETR	13428	VOJTĚCH	13451	JANA
13404	JOSEF	13429	FILIP	13452	EVA
13405	PAVEL	13430	ADAM	13453	PETRA
13406	MARTIN	13431	MILOSLAV	13454	MAJKA
13407	JAROSLAV	13432	MATĚJ	13455	HANA
13408	TOMÁŠ	13433	ALEŠ	13456	ANNA
13409	MIROSLAV	13434	JAROMÍR	13457	LENKA
13410	ZDENĚK	13435	LIBOR	13458	KATKA
13411	FRANTIŠEK	13436	DOMINIK	13459	LUCIE
13412	VÁCLAV	13437	PATRIK	13460	ALENA
13413	MICHAL	13438	VLASTIMIL	13461	VERONIKA
13414	MILAN	13439	JINDŘICH	13462	MARTINA
13415	KAREL	13440	MILOŠ	13463	JITKA
13416	JAKUB	13441	JÁN	13464	BIG BOSS
13417	LUKÁŠ	13442	PETER	13465	2 x MĚŘ
13418	DAVID	13443	ONDREJ	13466	TATÍNEK
13419	VLADIMÍR	13444	JOZEF	13467	DĚDEČEK
13420	LADISLAV	13445	PAVOL	13468	ŠIKULA
13421	ONDŘEJ	13446	L'UBOMÍR	13469	MISTR
13422	ROMAN	13447	KAROL	13470	MACHR
13423	STANISLAV	13448	RADOSLAV	13471	BOREC
13424	MAREK	13449	VOJTĚCH	13472	UŽ JE MŮJ
13425	RADEK	13450	ZDENKO	13473	MŮJ METR

FALTMETERSTÄNDER

· Montage des Ständers 13399

- 13401 · 15 ks
- 13402 · 15 ks
- 13403 · 15 ks
- 13404 · 15 ks
- 13405 · 15 ks
- 13406 · 15 ks
- 13412 · 15 ks
- 13413 · 15 ks
- 13414 · 15 ks
- 13415 · 15 ks
- 13416 · 15 ks
- 13417 · 15 ks
- 13418 · 15 ks
- 13419 · 15 ks
- 13420 · 15 ks
- 13421 · 10 ks
- 13422 · 10 ks
- 13423 · 10 ks
- 13424 · 10 ks
- 13425 · 10 ks
- 13426 · 10 ks
- 13427 · 10 ks
- 13428 · 10 ks
- 13429 · 10 ks
- 13430 · 10 ks
- 13431 · 10 ks
- 13432 · 10 ks
- 13433 · 10 ks
- 13434 · 10 ks
- 13435 · 10 ks
- 13436 · 10 ks
- 13437 · 10 ks
- 13438 · 10 ks
- 13439 · 10 ks
- 13440 · 10 ks



Nr.	Spezifikation	
13399	Ständer montiert	1
13400	Ständer ohne Meter	1



FESTA

MESSSCHIEBER, DIGITAL



INOX	Nr.	Spezifikation	10
	14007	150 0,01 mm	10
	14008	200 0,01 mm	10
	14009	300 0,01 mm	10



MESSSCHIEBER, DIGITAL, FIBERGLASS



· Genauigkeit 0,2 mm, Auflösung 0,1 mm

	Nr.	Spezifikation	10
	14013	150 0,2 mm	10

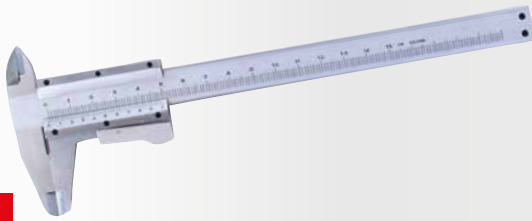

FESTA

MESSSCHIEBER



INOX	Nr.	Spezifikation	10
	14004	150 0,02 mm	10

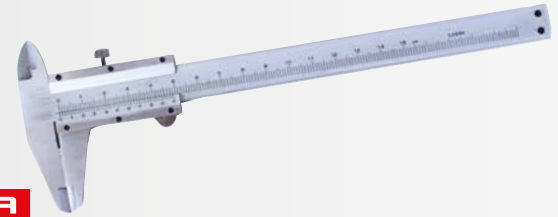

FESTA

MESSSCHIEBER



INOX	Nr.	Spezifikation	10
	14001	150 0,02 mm	10
	14002	200 0,02 mm	10
	14003	300 0,02 mm	10



FESTA

MIKROMETER



	Nr.	Spezifikation	10
	14040	0 - 0,25 0,01 mm	10
	14045	25 - 50 0,01 mm	10



MESSSCHIEBER

HOBBY

PLASTIC	Nr.	Spezifikation	50
	14006	150 mm	50



FESTA

MESSUHR



INOX	Nr.	Spezifikation	10
	14035	0 - 10mm 0,01 mm	10



FUGENLEHREN

· 20 Blätter



	Nr.	Spezifikation	10
	14080	0,05 - 1 mm	10



ZEICHNUNGSZIRKEL



	Nr.	Spezifikation	10
	13285	200 mm	10



FESTA

REISSNADEL



	Nr.	Spezifikation	50
	13281	150 mm	50



FESTA

REISSNADEL



	Nr.	Spezifikation	50
	13282	200 mm	50

FESTA

MASSTAB MIT HANDGRIFF

ALU



Nr.	Spezifikation	
14030	600 mm	6

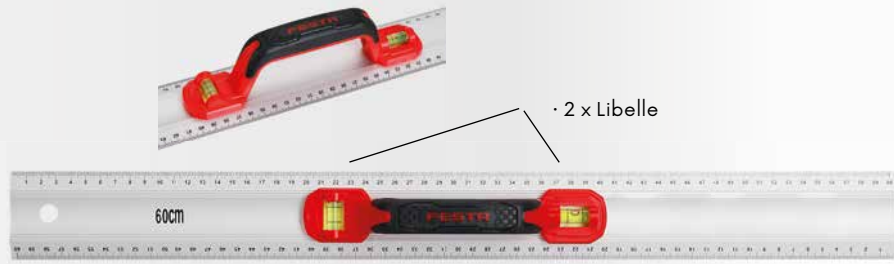

FESTA

MASSTAB AUS ALUMINIUM

ALU



Nr.	Spezifikation	
14015	400 mm	48
14017	600 mm	50
14019	1000 mm	40



FESTA

MASSTAB AUS STAHL

INOX



Nr.	Spezifikation	
14010	300 mm	10
14011	600 mm	10
14012	1000 mm	10

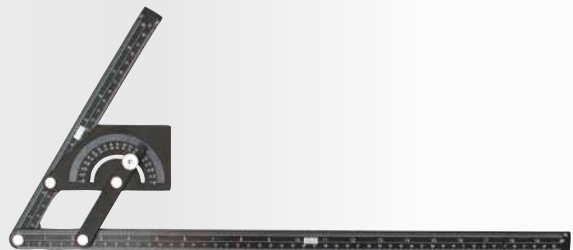
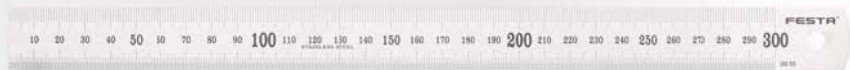

FESTA

WINKELMESSER MIT DREHBAREM ARM

· mit Etui

Nr.	Spezifikation	
14060	0° - 180° · 150 x 200 mm	10
14070	0° - 180° · 300 x 500 mm	5

WINKELMESSER

HOBBY

Nr.	Spezifikation	
14075	0° - 180° · 230 x 500 mm	30



MEHRZWECK-MASSTAB

Nr.	Spezifikation
14077	



10

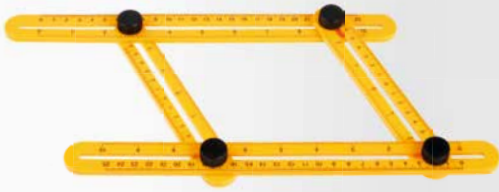

MEHRZWECK-MASSSTAB



Nr.	Spezifikation	
14480	250 x 120 mm	1



VORLAGE ZUM KOPIEREN VON FORMEN



Nr.	Spezifikation	
14090	125 x 30 mm	1
14091	250 x 30 mm	1

FESTA

MULTIFUNKTIONSQUADRAT 3D



Nr.	Spezifikation	
14418		10



FESTA

MULTIFUNKTIONALER TISCHLERWINKEL



Nr.	Spezifikation	
14420	180 mm	10
14421	300 mm	10

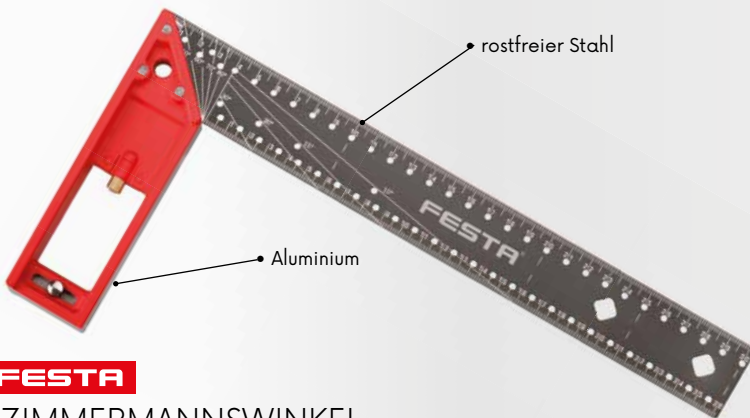

FESTA

ZIMMERMANNSWINKEL



Nr.	Spezifikation	
14415	300 mm	6
14417	400 mm	6



FESTA

MAURERWINKEL

ALU



Nr.	Spezifikation	
14445	600 x 600 mm	1
14446	1200 x 1200 mm	1



FESTA

WINKELSTÜCK

ALU



Nr.	Spezifikation	
14450	190 x 355 mm	6
14451	200 x 405 mm	6

FESTA

ZIMMERMANNSWINKEL



Nr.	Spezifikation	
14220	200 x 125 mm	10
14225	250 x 135 mm	10
14230	300 x 135 mm	10
14235	350 x 190 mm	10
14240	400 x 190 mm	10
14250	500 x 210 mm	10

FESTA

ZIMMERMANNSWINKEL



Nr.	Spezifikation	
14350	500 x 235 mm	10
14360	600 x 300 mm	10
14370	700 x 300 mm	10
14380	800 x 320 mm	10
14399	1000 x 360 mm	10



WINKELSTÜCK

Nr.	Spezifikation	
14410	300 x 200 mm	50
14411	600 x 400 mm	36

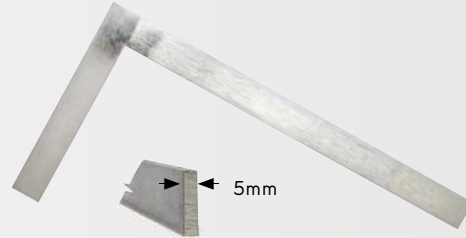

FLACHWINKEL

Zn

Nr.	Spezifikation	
14471	150 x 100 mm	25
14472	250 x 125 mm	25
14473	400 x 200 mm	30
14474	600 x 300 mm	25

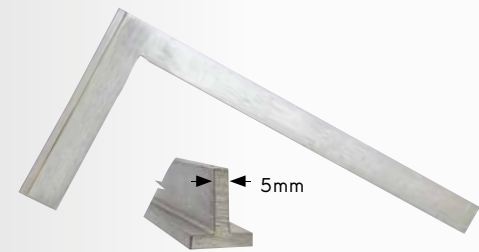

ANSCHALGWINKEL

Zn

Nr.	Spezifikation	
14490	100 x 50 mm	10
14491	150 x 75 mm	10
14492	250 x 125 mm	10
14493	400 x 200 mm	10
14494	600 x 300 mm	10



MAURERWINKEL

Nr.	Spezifikation	
14455	300 x 200 mm	50
14456	500 x 250 mm	50
14457	700 x 300 mm	40
14458	1000 x 450 mm	30



ZIMMERMANNSWINKEL

ALU HOBBY

Nr.	Spezifikation	
14425	250 x 130 mm	12
14430	300 x 130 mm	12
14435	350 x 156 mm	12
14440	400 x 156 mm	12



GEHRUNGSMASS AUS HOLZ



Nr.	Spezifikation	
14025	255 x 285 mm	1

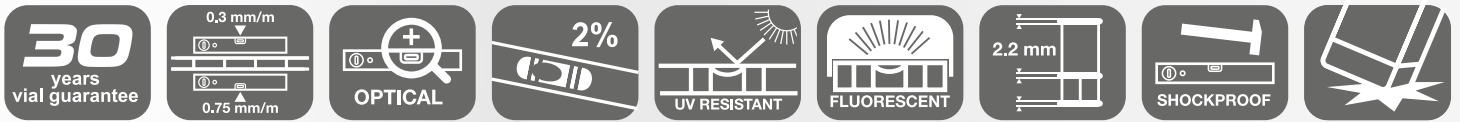

Jedes Stück wird elektronisch geprüft und hat eine eigene Registrierungsnummer, der Hersteller besitzt das ISO 9001-Zertifikat



HORIZONT.

MASTER - WASSERWAAGE, 2 LIBELLEN

ALU			
Nr.	Spezifikation		
15033	60 cm		10



HORIZONT.

MASTER - WASSERWAAGE, 3 LIBELLEN

ALU			
Nr.	Spezifikation		
15034	80 cm		10
15035	100 cm		10



HORIZONT.

MASTER - WASSERWAAGE, 3 LIBELLEN, MIT GRIFFEN

ALU			
Nr.	Spezifikation		
15036	120 cm		10
15037	150 cm		10
15039	200 cm		10

HORIZONT®

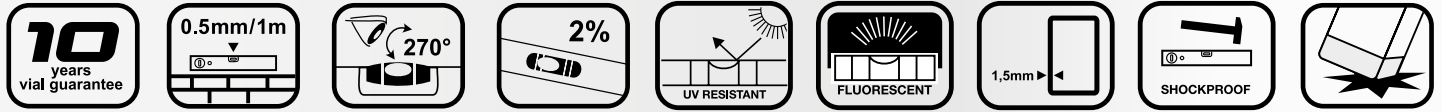

Jedes Stück wird elektronisch geprüft und hat eine eigene Registrierungsnummer, der Hersteller besitzt das ISO 9001-Zertifikat

HORIZONT®

WASSERWAAGE, 2 LIBELLEN



Nr.	Spezifikation	
15003	30 cm	30
15004	40 cm	30
15005	50 cm	30
15006	60 cm	30
15008	80 cm	30
15010	100 cm	30
15012	120 cm	10
15015	150 cm	10
15018	180 cm	10
15020	200 cm	10



HORIZONT®

WASSERWAAGE, 3 LIBELLEN



Nr.	Spezifikation	
15103	30 cm	30
15104	40 cm	30
15105	50 cm	30
15106	60 cm	30
15108	80 cm	30
15110	100 cm	30
15112	120 cm	10
15115	150 cm	10
15118	180 cm	10
15120	200 cm	10



HORIZONT®

WASSERWAAGE, 2 LIBELLEN + MAGNET



Nr.	Spezifikation	
15204	40 cm	30
15205	50 cm	30
15206	60 cm	30
15208	80 cm	30
15210	100 cm	30
15212	120 cm	10
15215	150 cm	10
15218	180 cm	10
15220	200 cm	10



HORIZONT®

WASSERWAAGE SCHRÄG,, 4 LIBELLEN



Nr.	Spezifikation	
15230	80 cm	10



HORIZONT

WASSERWAAGE MIT NEIGUNG, 1 LIBELLE

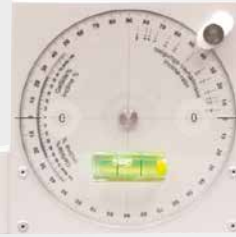

Nr.	Spezifikation	
15235	60 cm	1



HORIZONT

ABZIEHLATTE - OHNE LIBELLEN

ALU

Nr.	Spezifikation	
15310	100 cm	10
15315	150 cm	10
15318	180 cm	10
15320	200 cm	10
15325	250 cm	10
15330	300 cm	10
15335	350 cm	10
15340	400 cm	10



HORIZONT

ABZIEHLATTE - 1 LIBELLE

ALU

Nr.	Spezifikation	
15415	150 cm	10
15418	180 cm	10
15420	200 cm	10
15425	250 cm	10
15430	300 cm	10



HORIZONT

ABZIEHLATTE - 2 LIBELLEN

ALU

Nr.	Spezifikation	
15510	100 cm	10
15515	150 cm	10
15518	180 cm	10
15520	200 cm	10
15525	250 cm	10
15530	300 cm	10
15535	350 cm	10
15540	400 cm	5



HORIZONT

ABZIEHLATTE - 2 GRIFFE, OHNE LIBELLE

ALU

Nr.	Spezifikation	
15615	150 cm	10
15620	200 cm	10
15625	250 cm	10
15630	300 cm	10



HORIZONT.

ABZIEHLATTE - 2 GRIFFE, 2 LIBELLEN

ALU

Nr.	Spezifikation	
15710	100 cm	10
15715	150 cm	10
15720	200 cm	10
15725	250 cm	10
15730	300 cm	10
15735	350 cm	10
15740	400 cm	5



HORIZONT.

ABZIEHLATTE - 1 TRAPEZPROFIL

TRAPEZ

- Das Trapezprofil wird für feinere Oberflächenanpassungen verwendet
- geeignet für Stuckateure und Fassadenarbeiter
- geeignet für Dünnschichtputze

ALU

Nr.	Spezifikation	
15810	100 cm	10
15812	120 cm	10
15815	150 cm	10
15818	180 cm	10
15820	200 cm	10
15825	250 cm	10
15830	300 cm	10



HORIZONT.

ABZIEHLATTE - 1 H-PROFIL

PROFIL "h"

- Das "h"-Profil wird für feinere Oberflächenanpassungen verwendet
- geeignet für Stuckateure und Fassadenarbeiter
- geeignet zum Stuckieren von Deckenputzen

ALU

Nr.	Spezifikation	
15850	100 cm	10
15853	150 cm	10
15855	180 cm	10
15860	200 cm	10
15870	250 cm	10
15880	300 cm	10

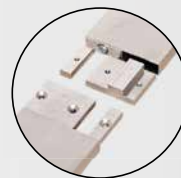

NEW

HORIZONT.

KUPPLUNG FÜR ABZIEHLATTE HORIZONT

Nr.

Spezifikation



15301



HORIZONT.

EINSTELLBARE ABZIEHLATTE



Nr.	Spezifikation	
15893	65 - 100 cm	1
15894	95 - 150 cm	1
15895	145 - 235 cm	1

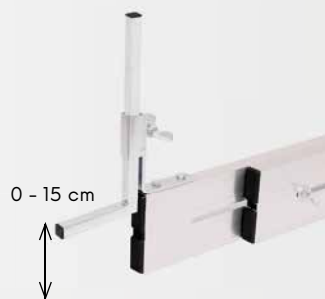

HORIZONT.

MAURERWINKEL

ALU

Nr.	Spezifikation	
14485	800 x 1200 mm	1
14486	1000 x 1500 mm	1



HORIZONT.
WASSERWAAGEN-
STÄNDER

· Montage des Ständers
15998

- 15003 · 5 ks
- 15004 · 5 ks
- 15005 · 5 ks
- 15006 · 5 ks
- 15008 · 5 ks
- 15010 · 5 ks
- 15012 · 5 ks
- 15015 · 3 ks
- 15018 · 3 ks
- 15020 · 3 ks
- 15108 · 3 ks
- 15206 · 3 ks
- 15210 · 3 ks

Nr.	Spezifikation	
15999	85 x 210 x 50 cm	1
15998	85 x 210 x 50 cm montiert	1

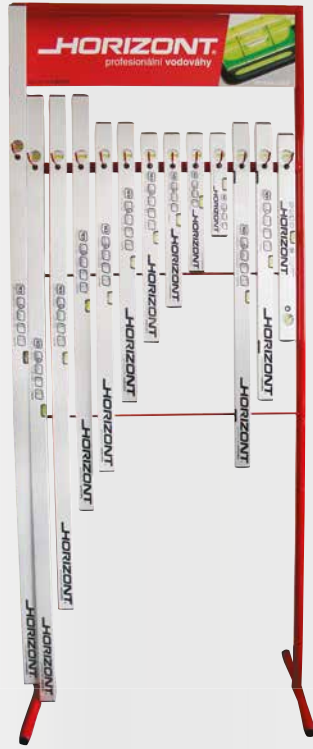

HORIZONT.
WASSERWAAGEN- UND
LATTENSTÄNDER

· Montage des Ständers
15996

- 15004 · 5 ks
- 15005 · 5 ks
- 15006 · 5 ks
- 15008 · 5 ks
- 15010 · 5 ks
- 15012 · 5 ks
- 15015 · 5 ks
- 15018 · 5 ks
- 15020 · 5 ks
- 15315 · 2 ks
- 15320 · 2 ks
- 15325 · 3 ks
- 15515 · 2 ks
- 15520 · 2 ks
- 15525 · 3 ks

Nr.	Spezifikation	
15997	55 x 75 x 40 cm	1
15996	55 x 75 x 40 cm montiert	1

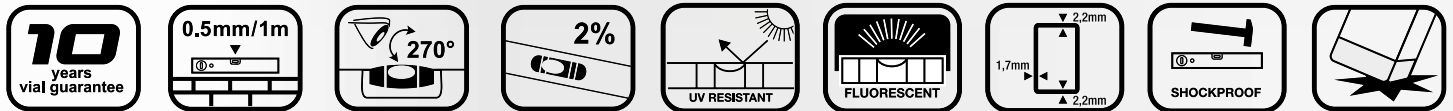

NEW

FESTA

WASSERWAAGE
3 LIBELLEN



Nr.	Spezifikation	
15754	400 mm	1
15756	600 mm	1
15758	800 mm	1
15760	1000 mm	1
15762	1200 mm	1
15768	1800 mm	1
15770	2000 mm	1



NIVELA

WASSERWAAGE NIVELLE - 2 LIBELLEN

- Genauigkeit 0,5 mm | 1 m (in Grundstellung)
- UV-stabile Flüssigkeit der Libelle
- Stoßfeste Endkappen
- Grundprofi Istärke 2,4 mm



Nr.	Spezifikation	
15904	40 cm	30
15906	60 cm	30
15908	80 cm	30
15910	100 cm	30
15912	120 cm	20
15915	150 cm	10
15920	200 cm	20



WASSERWAAGE - 3 LIBELLEN

ALU HOBBY

Nr.	Spezifikation	
15954	40 cm	60
15956	60 cm	60
15958	80 cm	60
15960	100 cm	30
15962	120 cm	30
15965	150 cm	30
15970	200 cm	30



WASSERWAAGE AN EINER SCHNUR



Nr.	Spezifikation	
15981		1



WASSERWAAGE MIT MAGNET, 3 LIBELLEN



Nr.	Spezifikation	
15980	230 mm	1

SÄULEN WASSERWAAGE

3 Libellen, Magnete, Befestigungsband



Nr.	Spezifikation	
26028		12

SCHLAUCH-WASSERWAAGE



Nr.	Spezifikation	
15992	Glasrohre - Schlauch 10 m	1
15993	Glasrohre - Schlauch 15 m	1
15990	Glasrohre	50
15991	Kunststoffrohre	50



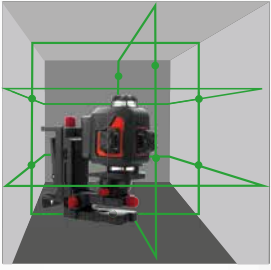

NEW

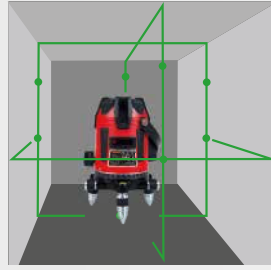

NEW



FESTA

LASER ALL LINE GRÜN 4 X 360°

- 2x horizontale Ebene + 2x vertikale Ebene (grüner Strahl)
- Selbstnivellierungsbereich $\pm 4^\circ$
- Genauigkeit: 0,2 mm/m
- im Innenbereich 30 m, mit Laser-Empfänger bis zu 50 m
- Pulsmodus – empfohlener Zubehöreffänger 26209
- Lieferumfang: Transportkoffer, Fernbedienung, Laserziel, Li-Ionen-Akku 5200 mAh, Profi-Halterung, Mini-Stativ, Ladegerät

$\pm 4^\circ$	max. 50 m	± 0.2 mm/m	II. class	515 nm
1/4"	5/8"	IP54	Li-Ion 3.7V 5.2Ah	

Nr. 26205

Spezifikation



1



FESTA

GRÜNER KREUZLASER

- 1x horizontale Ebene + 4x vertikale Ebene (grüner Strahl) + 1x Punkt
- Selbstnivellierungsbereich $\pm 3^\circ$
- Genauigkeit: 0,2 mm/m
- im Innenbereich 20 m, mit Laser-Empfänger bis zu 50 m
- Pulsmodus – empfohlener Zubehöreffänger 26209
- Lieferumfang: Transportkoffer, Laserzielscheibe, Li-Ionen-Akku 5200 mAh, Profi-Halterung, Mini-Stativ, Ladegerät

$\pm 3^\circ$	max. 50 m	± 0.2 mm/m	II. class	515 nm
5/8"	IP54	Li-Ion 3.7V 5.2Ah		

Nr. 26203

Spezifikation



1





FESTA

LASER ALL LINE GRÜN 3 X 360°

- 1x horizontale Ebene + 2x vertikale Ebene (grüner Strahl)
- Selbstnivellierbereich $\pm 4^\circ$
- Genauigkeit: 0,2 mm/m
- im Innenbereich 30 m, mit einem Laserempfänger bis zu 50 m
- Impulsmodus – empfohlener Zubehörempfänger 26209
- Lieferumfang: Tragetasche, 4 x AA-Alkalibatterien, Laserzielscheibe, Schutzbrille, Li-Ionen-Akku 2600 mAh, professioneller Halter, Ladegerät, Li-Ionen-Akkuhalter

$\pm 4^\circ$	INDOOR 30 m OUTDOOR 50 m	± 0.2 mm/m	II. class	515 nm
IP54	5/8"	1/4"	4x AA	Li-Ion 7,4V 2,6Ah



Nr. Spezifikation

26204

1



FESTA

GRÜNER KREUZLASER

- 1x horizontale Ebene + 1x vertikale Ebene (grüner Strahl)
- Selbstnivellierbereich $\pm 3^\circ$
- Genauigkeit: 0,2 mm/m
- im Innenbereich 20 m, mit einem Laserempfänger bis zu 50 m
- Impulsmodus – empfohlener Zubehörempfänger 26209
- Lieferumfang: Tragetasche, 2 x AA-Alkalibatterien, Halterung

$\pm 3^\circ$	INDOOR 20 m OUTDOOR 50 m	± 0.2 mm/m	II. class	515 nm
IP54	1/4"	2x AA		

Nr. Spezifikation

26201

1

FESTA

DISTANZMESSER

- Messbereich 0,05 - 50 m
- Messgenauigkeit ± 2 mm, Maßeinheit mm/in/ft
- Kontinuierliche Messung, Flächenmessung, Volumenmessung, Längenberechnung durch Dritte nach Satz des Pythagoras, LCD FSTN, Addition/Subtraktion, max./min. Messung
- maximaler Speicher für 100 Werte, vierzeiliges FSTNS-LCD-Display mit Hintergrundbeleuchtung,
- Laserwellenlänge 630 - 670 nm, Arbeitstemperatur 0 - 40°C
- Abmessungen 112 x 50 x 25 mm, Gewicht 90 g
- Lieferumfang: Tragetasche, 2 x AAA-Alkalibatterien

max 50 m	± 2 mm	m in ft	630 670 nm
IP54	2x AAA		

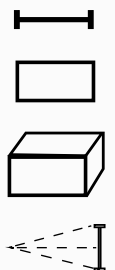

Nr. Spezifikation

26211

1



1/4" + 5/8"



60 - 150 cm

FESTA

LASEREMPFÄNGER

- bei Lasern mit Pulsbetrieb zur Reichweitenverlängerung auf bis zu 50 m
- Lieferumfang: 9 V Batterie, Halter für 26201, 26203, 26204, 26205

max 50m	±1.5mm 10m	5 kHz	IP54	1x 9V
----------------	-------------------	--------------	-------------	--------------



STATIV

ALU



Nr.	Spezifikation	
26209	dosah: 50 m	1

Nr.	Spezifikation	
26219	60 - 150 cm 1/4" + 5/8"	1

FESTA

DIGITALER NEIGUNGSMESSER

- 0° - 360°
- Genauigkeit ±0,1°
- Auflösung 0,1°
- automatische Abschaltfunktion
- HOLD-Funktion zum Feshalten des Messwertes
- beleuchtetes Display
- Spezifikation 60x60x25 mm
- Batterie 1xAAA



· Gehäuse

· magnetische Unterseite

84.5°	LCD DISPLAY	1x AAA	0-50°C	82g
--------------	--------------------	---------------	---------------	------------



Nr.	Spezifikation	
26218		1



FESTA

DIGITALER WINKELMESSER

200 mm	mm inch	LCD DISPLAY	0°-360°
0.05°	+/- 0.2°	MANUAL LOCKING	1x CR2032 3V



FESTA

WASSERWAAGE MIT DIGITALEM WINKELMESSER

- LCD-Display
- Messbereich 0° - 225°
- Auflösung 0,1°
- Genauigkeit ± 0,3

ALU	044.8°	LCD DISPLAY	3V LITHIUM
------------	---------------	--------------------	-------------------



Nr.	Spezifikation	
26216	300 mm	1

FESTA

MULTIMETER

- DC Spannungsmessung: 200 mV - 300 V
- AC Spannungsmessung: 200 mV - 300 V
- DC Strommessung: 2000 A - 10 A
- Widerstandsmessung: 200 - 2 M
- Batteriecheck: 1.5V, 9V
- Anzeige für niedrigen Batteriestand
- Überspannungsschutz

- IEC61010
- CATIII 300V
- GS Zertifiziert
- Stromversorgung: 9 V Batterie (6F22)
- Maße: 70x128x28 mm
- Gewicht: 137 g (Mit Batterie)
- Zubehör: Testkabel



Nr.	Spezifikation
18429	1

FESTA

SPANNUNGSPRÜFER

- AC / DC - 6 V, 12 V, 24 V, 50 V, 120 V, 230 V, 400 V
- Beständigkeit gegen das Eindringen von Wasser IP54
- Polarität
- CAT III 400 V



Nr.	Spezifikation
18428	1

Laserliner®

LUXTEST-MASTER

Professionelles Lichtintensitätsmessgerät

- Messung der Beleuchtungsstärke an Arbeitsplätzen, in Büros, öffentlichen Gebäuden und in der Industrie
- empfindliche Fotodioden mit Cosinus-Korrektur für Weitwinkel-Lichtmessung
- relative Messfunktion für Referenzmessung und Vergleich
- Spitzenfunktion zur Erfassung schneller Änderungen des Beleuchtungsniveaus.
- Funktion der automatischen Wertspeicherung.
- automatische und manuelle Bereichsumschaltung
- Reset-Funktion
- Messung der Messgröße: lux (lm |m2), Fußkerzen (lm |ft2)
- Min. | max. Anzeige
- 1 | 4" Gewinde für Stativbefestigung



Nr.	Spezifikation
	Messbereich: 20 Lux ... 200000 Lux
26520	Präzision: ± 3% (Referenzwert 2854 K)
	Erlaubte Winkelabweichung: ± 2% (30°), ± 6% (60°)



Spezifikation
Anlieferung mit: Batterie, Transportkoffer

Laserliner®

AIRFLOWTEST-MASTER

Professionelles Anemometer zur Messung des Luftstroms, des Volumenstroms und der Windgeschwindigkeit

- integrierter Sensor zur Messung von Umgebungstemperatur, relativer Luftfeuchtigkeit und Taupunkt
- USB-Schnittstelle zum Speichern von Messdaten
- pc software
- großes Laufrad: 65 mm.
- Min. | max. Anzeige.
- 1 | 4"-Gewinde zum Anschluss an ein Stativ für Langzeitmessungen
- beleuchtetes, übersichtliches Display mit permanent sichtbaren Werten von Umgebungstemperatur und relativer Luftfeuchtigkeit



Nr.	Spezifikation
	Durchfluss: 0.80...30 m s ± 2%
26521	Umgebungstemperatur: -10...60°C ± 1.5°C
	Rel. Luftfeuchtigkeit: 20%...80% ± 3%
	Luftstrom: 0...99990 CMM



NAHRÁVÁNÍ DAT NA PC

Spezifikation
Anlieferung mit: PC-Software, USB-Kabel, Akku, Transportkoffer





FESTA

ZIMMERMANN'SBLEISTIFT HB



MOQ 12

Nr.	Spezifikation	MOQ
13270	HB · 180 mm	96
13271	HB · 180 mm · Set 3 St.	32
13265	HB · 250 mm	96



FESTA

ZIMMERMANN'SBLEISTIFT HB



MOQ 50



Nr.	Spezifikation	MOQ
13269	HB · 180 mm	50
13266	HB · 250 mm	50



FESTA

ZIMMERMANN'SBLEISTIFT HB



MOQ 12

Nr.	Spezifikation	MOQ
13272	HB · 250 mm	96
13264	HB · 250 mm · ohne Druck	96



FESTA

ZIMMERMANN'SBLEISTIFT HB



MOQ 50



Nr.	Spezifikation	MOQ
13268	250 mm	50



FESTA

HB-DREIECKBLEISTIFT



MOQ 12

Nr.	Spezifikation	MOQ
13278	250 mm	96



FESTA

6H-BLEISTIFT

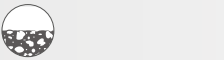

MOQ 12

Nr.	Spezifikation	MOQ
13275	6H · 250 mm	96



FESTA

BLEISTIFT FÜR GLAS UND KERAMIK



MOQ 12

Nr.	Spezifikation	MOQ
13273	175 mm Rotstift - Glas, Keramik	144



FESTA

BLEISTIFT MIT BUNTER MINE

Nr.	Spezifikation	MOQ
13274	175 mm, rot - blau	96



ZIMMERMANN'SBLEISTIFT HB



MOQ
12

Nr.	Spezifikation	
13280	180 mm	96



BLEISTIFT MIT ROTER MINE

MOQ
12

Nr.	Spezifikation	
13276	175 mm	144



· Schmirgel

BLEISTIFTSPITZER



Nr.	Spezifikation	
13261		12



FESTA

HB-TIEFMARKER

· Ersatzminen 13263, 13267



Nr.	Spezifikation	
13288		20



FESTA

HB-TIEFMARKER

· Ersatzminen 13263, 13267



Nr.	Spezifikation	
13262	150 mm	20



FESTA

HB-BLEISTIFT MIT AUSTAUSCHBARER MINE



Nr.	Spezifikation	
13279	HB-Bleistift + austauschbare Mine	24
13284	Ersatzminen 5 St.	20

FESTA

ERSATZMINEN FÜR HB-TIEFMARKER

· für 13262, 13288



Nr.	Spezifikation	
13267	2x gelb 2x rot 2x blau	1

FESTA

ERSATZMINEN FÜR HB-TIEFMARKER

· für 13262, 13288



Nr.	Spezifikation	
13263	6x schwarz	20





PERMANENTMARKER



Nr.	Spezifikation	
13200	weiß	1
13201	schwarz	1
13202	rot	1



PERMANENTMARKER



- extra starke Spitze
- zum Markieren auch auf fettigen und feuchten Oberflächen



Nr.	Spezifikation	
13216	rot	12
13217	schwarz	12
13218	blau	12
13219	grün	12



PERMANENTMARKER



- 2 Typen von Markerspitzen
- zum Markieren auch auf fettigen und feuchten Oberflächen



Nr.	Spezifikation	
13227	weiß	ALU-Gehäuse 40
13222	weiß	PVC-Gehäuse 12
13228	rot	ALU-Gehäuse 40
13229	schwarz	ALU-Gehäuse 40
13230	blau	ALU-Gehäuse 12
13231	grün	ALU-Gehäuse 12



PERMANENTMARKER



Nr.	Spezifikation	
13214	weiß	12
13225	rot	12
13226	schwarz	12
13223	blau	12
13224	grün	12



PERMANENTMARKER



Nr.	Spezifikation	
13235	rot	12
13236	schwarz	12
13237	blau	12
13238	grün	12



FESTA

PERMANENTMARKER,
TIEFMARKER



Nr.	Spezifikation	
13246	● schwarz	1
13247	● rot	1
13248	○ weiß	1



PERMANENTMARKER,
BEIDSEITIG

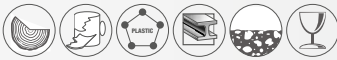

MOQ
12



Nr.	Spezifikation	
13206	○ weiß	12



PERMANENTMARKER,
BEIDSEITIG



MOQ
12



Nr.	Spezifikation	
13212	schwarz	12



PERMANENTMARKER,
BEIDSEITIG



MOQ
12



Nr.	Spezifikation	
13207	● rot	12
13208	● blau	12



PERMANENTMARKER, MINI



· Markerlänge 9 cm



MOQ
72



Nr.	Spezifikation	
13205	● ● ● ● ●	72



FESTA

**MARKER UNIVERSAL
SET 5 ST.**

· Ø 13 x 110 mm

5x



Nr.	Spezifikation	
13240	5 Farben	20
13241	● rot	20
13242	● schwarz	20

Nr.	Spezifikation	
13243	● gelb	20
13244	● grün	20
13245	○ weiß	20



**MOBILER HALTER
FÜR SOPPEC-SPRAY**

· für Sprays Trackmarker und Fluo



Nr.	Spezifikation	
13296		1



**WACHSBLEISTIFT
SET 6 ST.**

6x



Nr.	Spezifikation	
13277	● ● ● ● ● ●	88



WEISSE KREIDE

12x



Nr.	Spezifikation	
13260	12 x 12 x 80 mm	46



MOBILER PISTOLENHALTER FÜR SOPPEC-SPRAY

· für Sprays Trackmarker und Fluo



Nr.	Spezifikation	
13295		1



FLUORESZENZSPRAY TRACKMARKER 500ML

- Hohe Sichtbarkeit – fluoreszierendes Pigment
- Sicherheitsverschluss
- Schnelltrocknend 10 Min.
- 3 Monate Haltbarkeit
- Anwendung – Beton, Asphalt, Gras, Kies, Sand, Stein, Holz



Nr.	Spezifikation	
13250	gelb	12
13251	rot	12
13252	orange	12
13253	grün	12
13254	rosa	12
13249	blau	12



FLUORESZENZSPRAY MARK 6M FLUO 500 ML

- Hohe Sichtbarkeit – fluoreszierendes Pigment
- Sicherheitsverschluss
- Schnelltrocknend 10 Min.
- Haltbarkeit 6 Monate
- Anwendung – Beton, Asphalt, Gras, Kies, Sand, Stein, Holz, Glas



Nr.	Spezifikation	
13360	gelb	12
13361	rot	12
13362	orange	12
13363	grün	12
13364	rosa	12
13365	weiß	12



FLUORESZENZSPRAY FLUO 500ML

- Hohe Sichtbarkeit – fluoreszierendes Pigment
- Sicherheitsverschluss
- Schnelltrocknend 10 Min.
- Haltbarkeit 12 Monate
- Anwendung – Beton, Asphalt, Gras, Kies, Sand, Stein, Holz, Glas



Nr.	Spezifikation	
13350	gelb	12
13351	rot	12
13352	orange	12
13353	grün	12
13354	rosa	12
13355	weiß	12



FLUORESZENZSPRAY IDEAL 500ML

- Hohe Sichtbarkeit – fluoreszierendes Pigment
- Sicherheitsverschluss
- Schnelltrocknend 10 Min.
- Haltbarkeit 12 Monate
- Anwendung – Beton, Asphalt, Gras, Kies, Sand, Stein, Holz



Nr.	Spezifikation	
13255	gelb	12
13256	rot	12
13257	orange	12
13258	grün	12
13259	rosa	12



KDS®

Messer der japanischen Firma KDS

- hervorragende Ergonomie des Griffs
- hohe Leistung und Lebensdauer der Schneidkanten
- die besten verwendeten Schneidkantenmaterialien
- geringer Schnittwiderstand für leichtes Schneiden



KDS® ABBRECHMESSER



Nr.	Spezifikation	Stückzahl
16002	LC405 18 mm grün	25
16011	LB10 Ersatzklingen	10



KDS® ABBRECHMESSER



Nr.	Spezifikation	Stückzahl
16003	G11 18 mm + 2 klingen	10
16012	GB10 Ersatzklingen	10



KDS® ABBRECHMESSER



Nr.	Spezifikation	Stückzahl
16019	L19 18 mm + 2 klingen	10
16011	LB10 Ersatzklingen	10
16012	GB10 Ersatzklingen	10



KDS® ABBRECHMESSER



Nr.	Spezifikation	Stückzahl
16004	H11 25 mm	10
16013	HB10 Ersatzklingen	10



KDS® ABBRECHMESSER



Nr.	Spezifikation	Stückzahl
16005	S14 9 mm + 2 klingen	10
16010	SB10 Ersatzklingen	10



KDS® SKALPELL



Nr.	Spezifikation	Stückzahl
16006	D12 + 16 klingen	10

KDS® ERSATZKLINGE KDS



Nr.	Spezifikation	Stückzahl
16010	SB10 9 0,38 mm	13 segmente 20
16011	LB10 18 0,5 mm	15 segmente 20
16012	GB10 18 0,6 mm	15 segmente 20
16013	HB10 25 0,7 mm	7 segmente 10



KDS® ERSATZKLINGE KDS

- Sonderlegierung
- doppeltes Schleifen
- erhöhte Lebensdauer
- geringer Schneidwiderstand
- der ein leichtes Schneiden erlaubt



Nr.	Spezifikation	Stückzahl
16016	LB10B 18 0,5 mm	8 segmente 20
16017	HB10B 25 0,7 mm	7 segmente 10



KDS® STÄNDER FÜR ABBRECHMESSER

Nr.	Spezifikation	Stückzahl
16999	Werbbeständer	1
16998	montierter Werbbeständer	1



• Beispielfoto

- Montage des Ständers 16998 : 16001 · 5 Stck
- 16003 · 5 Stck
- 16004 · 3 Stck
- 16005 · 3 Stck
- 16006 · 2 Stck
- 16008 · 3 Stck
- 16010 · 4 Stck
- 16012 · 4 Stck
- 16013 · 1 Stck
- 16016 · 4 Stck
- 16018 · 4 Stck
- 16019 · 4 Stck
- 16020 · 4 Stck



FESTA



Klingenbrechsystem



FESTA
INDUSTRY

ABBRECHMESSER

· Anti-Rutsch-Gummibeschichtung



Nr.	Spezifikation	
16099	18 mm	12

FESTA[®]



FESTA[®]

**ABBRECHMESSER
MIT KERAMIKKLINGE**

· 3x schärfer als eine Stahlklinge
· 10x längere Lebensdauer
· hitzebeständig, nicht leitfähig, nicht magnetisch



Nr.	Spezifikation	
16131	18 mm	10
16066	Ersatzklinge 18 mm, 5 Stck	10

FESTA[®]

ABBRECHMESSER



Nr.	Spezifikation	
16110	L11 18 mm + 1 Klinge	12

FESTA[®]

ABBRECHMESSER



Nr.	Spezifikation	
16100	L12 18 mm + 1 Klinge	12

FESTA[®]

ABBRECHMESSER



Nr.	Spezifikation	
16105	L17 18 mm + 1 Klinge	12

FESTA[®]

ABBRECHMESSER



Nr.	Spezifikation	
16125	L4 9 mm	24
16120	L8 18 mm	24

FESTA[®]

ABBRECHMESSER



Nr.	Spezifikation	
16115	L10 9 mm	24



FESTA
ABBRECHMESSER

Nr.	Spezifikation	
16150	18 mm	24
16151	18 mm ohne FESTA-Logo	20



FESTA
ABBRECHMESSER

Nr.	Spezifikation	
16136	18 mm	1



FESTA
ABBRECHMESSER

Nr.	Spezifikation	
16137	25 mm	1



FESTA
ABBRECHMESSER
· rutschhemmende Gummibeschichtung

Nr.	Spezifikation	
16090	18 mm	12



FESTA
ABBRECHMESSER
· rutschhemmende Gummibeschichtung

Nr.	Spezifikation	
16091	25 mm	6



FESTA
ABBRECHMESSER
· rutschhemmende Gummibeschichtung

Nr.	Spezifikation	
16145	L25 18 mm	12



FESTA
ABBRECHMESSER
· rutschhemmende Gummibeschichtung

Nr.	Spezifikation	
16144	L24 18 mm	12



ABBRECHMESSER

Nr.	Spezifikation	
16143	18 mm	12



ABBRECHMESSER

Nr.	Spezifikation	
16142	18 mm	12



ABBRECHMESSER

Nr.	Spezifikation	
16025	18 mm	12



FESTA
ABBRECHMESSER

Nr.	Spezifikation	
16029	18 mm	25



FESTA
ABBRECHMESSER
· rutschhemmende Gummibeschichtung

Nr.	Spezifikation	
16146	18 mm	12



FESTA

ABBRECHMESSER

· rutschhemmende Gummibeschichtung



Nr.	Spezifikation	
16147	25 mm	12



FESTA

ABBRECHMESSER

· rutschhemmende Gummibeschichtung



Nr.	Spezifikation	
16130	L18 18 mm + 5 klingen	12



FESTA

ABBRECHMESSER

· rutschhemmende Gummibeschichtung



Nr.	Spezifikation	
16135	L20 25 mm + 5 klingen	6



FESTA

ABBRECHMESSER

· rutschhemmende Gummibeschichtung



Nr.	Spezifikation	
16140	L22 18 mm	12



FESTA

ABBRECHMESSER

· rutschhemmende Gummibeschichtung



Nr.	Spezifikation	
16034	25 mm	12



FESTA

ABBRECHMESSER



Nr.	Spezifikation	
16085	9 mm	24



FESTA

ABBRECHMESSER



Nr.	Spezifikation	
16086	18 mm	24



SICHERHEITSMESSER

Nr.	Spezifikation	
16044		20



SICHERHEITSMESSER

· samozatahovací klinge

Nr.	Spezifikation	
16057	135 mm	12



FESTA

SICHERHEITSMESSER



Nr.	Spezifikation	
16058		6
16074	Ersatzklinge 10 Stck	1

16074



NEW



FESTA

KLAPPMESSER

+2 SK4



Nr.	Spezifikation	
16039		6
16087	Ersatzklinge	1



FESTA

TURBO-MESSER

+5 ALU



Nr.	Spezifikation	
16037	+ 5 klingen	6



FESTA

KLAPPMESSER

+5 ALU



Nr.	Spezifikation	
16023	Klappmesser + 5 klingen	12
16071	Ersatzklinge 10 Stck	10



FESTA

KLAPPMESSER, KLINGEN-SET

ALU

Nr.	Spezifikation	
16095	25 klingen	1

SKALPELLEN-SET

22x



Nr.	Spezifikation	
16282		24



SKALPELLEN-SET

13x



Nr.	Spezifikation	
16281		10



FESTA

MESSER MIT ARRETIERUNG

rutschhemmende Gummibeschichtung

ALU +2



Nr.	Spezifikation	
16035	+ 2 klingen	12



FESTA

MESSER MIT ARRETIERUNG

ALU +3



Nr.	Spezifikation	
16033	NP 110 + 3 klingen	5



MESSER MIT ARRETIERUNG

ALU			
Nr.	Spezifikation		
16032	NP 109	48	



MESSER MIT ARRETIERUNG

ALU			
Nr.	Spezifikation		
16031	NS 107 B	24	



MESSER

ALU			
Nr.	Spezifikation		
16030	NS 107	24	



ABBRECHMESSER

ALU			
Nr.	Spezifikation		
16046	18 mm	12	



ABBRECHMESSER

ALU			
Nr.	Spezifikation		
16028	S 201 18 mm	24	



ABBRECHMESSER

ALU			
Nr.	Spezifikation		
16026	P 205 18 mm	30	



ABBRECHMESSER

HOBBY			
Nr.	Spezifikation		
16021	P 201 9 mm	60	



ABBRECHMESSER

HOBBY			
Nr.	Spezifikation		
16024	P 204 18 mm	60	



ABBRECHMESSER

HOBBY			
Nr.	Spezifikation		
16141	18 mm	24	

MOQ 24

rutschhemmende Gummibeschichtung



MESSER-SET

HOBBY	12x		
Nr.	Spezifikation		
16053	9 mm	12	
16055	18 mm	12	



MESSER-SET

HOBBY	3x		
Nr.	Spezifikation		
16043		24	



MESSER FÜR FUSSBODENBELÄGE

für Teppiche und Fussbodenbeläge

Nr.	Spezifikation	
16036	45 mm	12



HAKENMESSER

für Teppiche und Fussbodenbeläge

Nr.	Spezifikation	
16041		12



50 mm

KRATZEISEN

ALU		
Nr.	Spezifikation	
16059	50 mm	10
16082	Ersatzklinge	1



100 mm

KRATZEISEN

zur Verwendung mit 18-mm-Klingen für Abbrechmesser

ALU

Nr.	Spezifikation	
16054	100 mm	1



100 mm

KRATZEISEN

Nr.	Spezifikation	
16052	48 cm Länge	6
16070	klinge	25



38 mm

FESTA

GUMMIERTER SCHABER

protiskluzové pogumování

Nr.	Spezifikation	
16049		12
16069	Ersatzklinge	1



60 mm

KRATZEISEN

Nr.	Spezifikation	
16051		24



55 mm

KRATZEISEN

Nr.	Spezifikation	
16050		24



SET ZUM AUFTRAGEN UND ENTFERNEN VON SILIKON

3x

Nr.	Spezifikation	
16042		12





FESTA
ERSATZKLINGE

- 7 Segmente
- 3x längere Lebensdauer
- doppeltes Schleifen
- geringer Schneidwiderstand

SK2 10x



Nr.	Spezifikation	
16064	25 0,7 mm	20



FESTA
ERSATZKLINGE

- 8 Segmente
- 3x längere Lebensdauer
- doppeltes Schleifen
- geringer Schneidwiderstand

SK2 10x



Nr.	Spezifikation	
16062	18 0,7 mm	10



FESTA
ERSATZKLINGE

- 15 Segmente
- 3x längere Lebensdauer
- doppeltes Schleifen
- geringer Schneidwiderstand

SK2 10x



Nr.	Spezifikation	
16063	18 0,7 mm	10



FESTA
ERSATZKLINGE, KERAMISCH

- 8 Segmente
- 3x schärfer als eine Stahl Klinge
- 10x längere Lebensdauer
- Hitzebeständig, nicht leitfähig, nicht magnetisch

5x



Nr.	Spezifikation	
16066	18 0,6 mm	10



ERSATZKLINGE

- 8 Segmente
- doppeltes Schleifen

10x



Nr.	Spezifikation	
16078	18 0,5 mm	25



ERSATZKLINGE

- 8 Segmente
- doppeltes Schleifen

10x



Nr.	Spezifikation	
16077	18 0,6 mm	25



ERSATZKLINGE

- 7 Segmente

10x



Nr.	Spezifikation	
16068	25 0,6 mm	20



ERSATZKLINGE

- 8 Segmente

10x



Nr.	Spezifikation	
16065	18 0,5 mm	60



ERSATZKLINGE

- 15 Segmente

10x



Nr.	Spezifikation	
16081	18 0,5 mm	60



ERSATZKLINGE

- 4 Segmente

10x



Nr.	Spezifikation	
16067	18 0,5 mm	10



ERSATZKLINGE 30°

- 7 Segmente

10x



Nr.	Spezifikation	
16061	9 0,4 mm	60



ERSATZKLINGE

- 13 Segmente

10x



Nr.	Spezifikation	
16060	9 0,45 mm	10



FESTA
ERSATZKLINGE

10x



Nr.	Spezifikation	
16072	R 004	10



FESTA
ERSATZKLINGE

10x



Nr.	Spezifikation	
16075	R 003	10



ERSATZKLINGE

10x

Nr.	Spezifikation	
16071	R 001	60

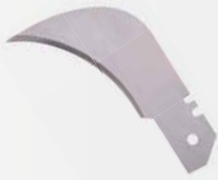

ERSATZKLINGE

5x

Nr.	Spezifikation	
16083	18 mm	50



ERSATZKLINGE

10x

Nr.	Spezifikation	
16073	R 002	60



ERSATZKLINGE

5x

Nr.	Spezifikation	
16084	18 mm	50

FESTA

ERSATZKLINGE

für 16058

10x

Nr.	Spezifikation	
16074		1



ERSATZKLINGE

für 34315

Nr.	Spezifikation	
34316		1



ERSATZKLINGE FÜR SCHABER

für 16052

Nr.	Spezifikation	
16070	100 mm	25



FESTA

MESSER FÜR MINERALWOLLE

Nr.	Spezifikation	
16198	44,5 33 cm	12



FESTA

ISOLATIONSMESSER

für Mineralwolle, Styropor

Nr.	Spezifikation	
16199	48 35 cm	10



FESTA

MACHETE

TEFLON

Nr.	Spezifikation	
45069	490 mm	6



FESTA

MACHETE

TEFLON

Nr.	Spezifikation	
44950	490 mm	4



MACHETE AUS EDELSTAHL

INOX

Nr.	Spezifikation	
45083	430 mm	12
45084	600 mm	6



MACHETE

Griff aus Eschenholz

Nr.	Spezifikation	
45081	510 mm	36
45082	710 mm	36



FESTA

JAGDMESSER

- Nylon-Griff
- Klinge mit Teflon-Oberfläche
- Etui mit Sicherung und Clip



INOX	TEFLON	NYLON	Nr.	Spezifikation	
			16234	21 10 cm	10



FESTA

JAGDMESSER



INOX	TEFLON	Nr.	Spezifikation	
		16229	23 10 cm	12



FESTA

ZIMMERMANNSMEISSEL, MULTIFUNKTIONELL

- verstärkte Klinge



INOX	Nr.	Spezifikation	
	16231	20 8 cm	12



TECHNISCHES MESSER

- verstärkte Klinge

INOX	Nr.	Spezifikation	
	16230	21 10 cm	12



FESTA

MESSER FÜR FUSSBODENBELÄGE, GEBOGEN

Nr.	Spezifikation	
16225	20 8,5 cm	12



FESTA

ELEKTRIKERMESSER

- verstärkte Klinge

INOX	Nr.	Spezifikation	
	16212	15 3,2 cm	12



FESTA

ABISOLIERMESSER

Nr.	Spezifikation	
16201	Ø 8 - 27 mm	10



FESTA

ELEKTRIKERMESSER

INOX	Nr.	Spezifikation	
	16211	20 8,5 cm	10



FESTA

ELEKTRIKERMESSER

INOX	Nr.	Spezifikation	
	16210	20,5 9 cm	10



FESTA

OKULATIONSMESSER



INOX	Nr.	Spezifikation	24
	16219	19 11 cm	



FESTA

PFROPFMESSER



INOX	Nr.	Spezifikation	24
	16218	18,5 10,5 cm	



FESTA

VEREDELUNGSMESSER



INOX	Nr.	Spezifikation	24
	16220	18,5 11 cm	



FESTA

KLAPPMESSER



INOX	Nr.	Spezifikation	24
	16235	17,5 8,5 cm	



FESTA

KLAPPMESSER



INOX	Nr.	Spezifikation	24
	16221	21 12 cm	



FESTA

KLAPPMESSER



INOX	Nr.	Spezifikation	24
	16236	22,5 10 cm	



FESTA

KLAPPMESSER



INOX	Nr.	Spezifikation	1
	16209	14,5 5,5 cm	



FESTA

KLAPPMESSER



INOX	Nr.	Spezifikation	24
	16222	20 12 cm	



FESTA

KLAPPMESSER



INOX	ALU	Nr.	Spezifikation	24
		16223	18,5 10,5 cm	



FESTA

MEHRZWECK-KLAPPMESSER

· 10 Funktionen

INOX	Nr.	Spezifikation	24
	16228	27 10,5 cm	



FESTA

MEHRZWECK-KLAPPMESSER

· 10 Funktionen

INOX	Nr.	Spezifikation	24
	16226	17,5 7 cm	



MEHRZWECK-KLAPPMESSER

· 10 Funktionen

INOX	Nr.	Spezifikation	24
	16224	17,5 7 cm	



ZUSAMMENKLAPPBARES JAGDMESSER

· 10 Funktionen

INOX	Nr.	Spezifikation	24
	16227	20,5 10 cm	



FESTA

MULTIFUNKTIONSZANGE

· 9 Funktionen
· Gehäuse

CrV	Nr.	Spezifikation	12
	16232		



NEW

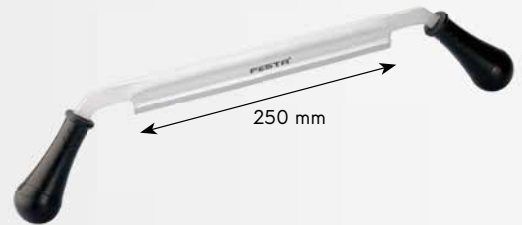

FESTA

ZUGMESSER

CrV	Nr.	Spezifikation	1
	24132	250/490 mm	



DOPPELHOBEL

	Nr.	Spezifikation	1
	19510	220 x 65 x 130 mm, messer 48 mm	



SCHLICHTHOBEL

	Nr.	Spezifikation	1
	19515	200 x 55 x 130 mm, messer 39 mm	



SIMSHOBEL

	Nr.	Spezifikation	1
	19520	225 x 27 x 155 mm, messer 27 mm	



FESTA

MEISSEL

CrV

Nr.	Spezifikation	
19490	6 mm 290 mm	6
19491	8 mm 290 mm	6
19492	10 mm 290 mm	6
19493	12 mm 290 mm	6
19494	14 mm 290 mm	6
19495	16 mm 290 mm	6



FESTA

ZIMMERMANNSMEISSEL,
MULTIFUNKTIONELL

INOX

Nr.	Spezifikation	
16231	20 80 mm	12



FESTA

MEISSEL-SET MIT SCHÄRFER

CrV

5x

Nr.	Spezifikation	
19451	6 mm 10 mm 15 mm 20 mm 25 mm	10



FESTA

STECHBEITELSATZ

CrV

4x

Nr.	Spezifikation	
19457	6 mm 12 mm 19 mm 25 mm	10



STECHBEITELSATZ

4x

Nr.	Spezifikation	
19455	8 mm 12 mm 19 mm 25 mm	30

FESTA



FESTA

DREHMESSEL-SET

CrV

8x

Nr.	Spezifikation	
19458	365 125mm	1



STECHBEITELSATZ

4x

Nr.	Spezifikation	
19450	8 mm 12 mm 19 mm 25 mm	20



SCHNITZERMEISSEL-SET

12x CrV

Nr.	Spezifikation	
19459		5

FESTA

SCHÄRFER FÜR MESSER UND SCHERE 16V1



	30° Anvil	
	45° Anvil	
	50° Anvil	
	23° Bypass	
	35° Bypass	
	65° Bypass	
	Deburr Tool	



Nr. Spezifikation
45073



SCHLEIFSTEIN, OVAL

Nr. Spezifikation
45370 250 x 33 x 18 mm 20

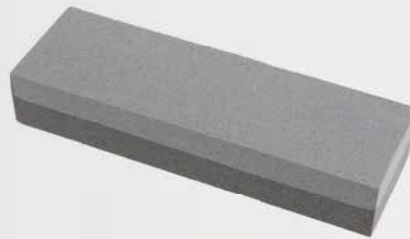

SCHLEIFSTEIN

Nr. Spezifikation
45045 150 x 50 x 30 mm 1



SENSENSCHLEIFSTEIN

Nr. Spezifikation
45046 205 x 15 mm 100



MESSER- UND SCHERENSCHÄRFER

Nr. Spezifikation
16991 20



MESSER- UND SCHERENSCHÄRFER

Nr. Spezifikation
16990 Ø 50 mm 1



MESSER- UND SCHERENSCHÄRFER

Nr. Spezifikation
45048 20



MESSER- UND SCHERENSCHÄRFER 6 IN 1

Nr. Spezifikation
45068 10





FESTA
POWER X TOOLS

**POLYFUSIONSSCHWEISSER
VON KUNSTSTOFFFROHREN**

- Spannung / Frequenz: 230 V / 50 Hz
- Leistungsaufnahme: 750 / 1500 W
- Temperatur: 0-300 C°
- Aufsätze: Ø 20,25,32,40,50,63 mm
- Gewicht: 1,6 kg



· im Lieferumfang enthalten: Maßband, Wasserwaage, Schraubendreher, Inbusschlüssel, Rohrschere, 6x Schweißaufsatz, Ständer, Blechkoffer



Nr.	Spezifikation	Icon
17182		1

FESTA
POWER X TOOLS

**SPITZEN-POLYFUSIONSSCHWEISSGERÄT
FÜR KUNSTSTOFFFROHRE**

- Spannung / Frequenz: 230 V / 50 Hz
- Leistungsaufnahme: 800 / 1000 W
- Temperatur: 0-300 C°
- Aufsätze: Ø 16, 20, 25, 32 mm
- Gewicht: 1 kg



· im Lieferumfang enthalten: Inbusschlüssel, 4x Schweißaufsatz, Ständer, Blechkoffer



Nr.	Spezifikation	Icon
17183		1

FESTA

ZANGE FÜR PVC-ROHRE

Ø max.
42 mm



Nr.	Spezifikation	Icon
17027		10
16315	Ersatzklinge	1

**ERSATZKLINGE
FÜR ZANGEN**
für Zange 17027



Nr.	Spezifikation	Icon
16315		1



FESTA



FESTA

**ZANGE FÜR
PVC-ROHRE**

Ø max.
32 mm



Nr.	Spezifikation	Icon
17037		12

**ZANGE FÜR
PVC-ROHRE**

Ø max.
42 mm



Nr.	Spezifikation	Icon
17026		6

NEW

FESTA

ROHRSCHEIDER

INOX ALU

ALU Cu PVC



Nr.	Spezifikation	
16305	Ø 22 mm	10
16306	Ø 15 mm	10
16307	NEW Ø 28 mm	10



NEW

FESTA

ROHRSCHEIDER

PLASTIC INOX

PVC

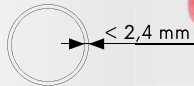

Nr.	Spezifikation	
16308	Ø 20 - 50 mm	10

FESTA

ROHRSCHEIDER

Ø 15 mm
Ø 22 mm
Ø 28 mm

3x INOX ALU

ALU Cu PVC



Nr.	Spezifikation	
16309		1



FESTA

DÜNNWANDROHR-ABSCHNEIDER



3-22 mm



Nr.	Spezifikation	Icon
16301		10
16311	Ersatzrad	1

FESTA

DÜNNWANDROHR-ABSCHNEIDER



6-64 mm



Nr.	Spezifikation	Icon
16304		6
16312	Ersatzrad	1

DÜNNWANDROHR-ABSCHNEIDER



3-32 mm



Nr.	Spezifikation	Icon
16303		10
16311	Ersatzrad	1

DÜNNWANDROHR-ABSCHNEIDER



3-32 mm



Nr.	Spezifikation	Icon
16300		10
16310	Ersatzrad	1

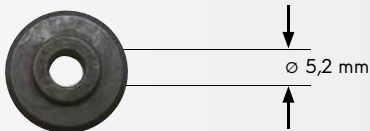

ERSATZRAD FÜR PVC-ROHRSCHEIDER



Nr.	Spezifikation	Icon
16310	Ø 17,5 mm x 6 m für 16300	1
16311	Ø 18,0 mm x 4,5 mm für 16303, 16301	1
16312	Ø 27,5 mm x 6 mm für 16304	1

FESTA

SCHERE FÜR PVC-LEISTEN UND ROHRE

Leisten, Rohre, Profile

5x Ø 17 mm Ø 20 mm Ø 27 mm



Nr.	Spezifikation	Icon
17050	60 250 mm	8

NEW

FESTA

ROHRENTGRATER



6-38 mm ALU



Nr.	Spezifikation	Icon
16319	Ø 6 - 38 mm	1

FESTA

ENTGRATMASCHINE



1/4"



Nr.	Spezifikation	Icon
16321		1

ROHRENTGRATER



6-32 mm



Nr.	Spezifikation	Icon
16320		1

FESTA

ENTGRATFRÄSER, MANUELL HSS



HSS Ø 25 mm 90°



Nr.	Spezifikation	Icon
20360		10

ENTGRATMASCHINE



Nr.	Spezifikation	Icon
20361		1



SCHLITZSCHRAUBENZIEHER



Nr.	Spezifikation	
18113	3 x 75 mm	12
18114	4 x 100mm	12
18115	5,5 x 125 mm	12
18116	6,5 x 150 mm	12
18118	8 x 175 mm	6
18120	10 x 200 mm	6



SCHRAUBENDREHER FLACH, KURZ

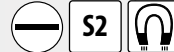

Nr.	Spezifikation	
18124	5,5 x 38 mm	12
18125	6,5 x 38 mm	12



SCHRAUBENDREHER PHILIPS



Nr.	Spezifikation	
18210	0 x 75 mm	12
18211	1 x 75 mm	12
18212	2 x 100 mm	12



SCHRAUBENDREHER PHILIPS, KURZ

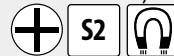

Nr.	Spezifikation	
18215	1 x 38 mm	12
18216	2 x 38 mm	12



SCHRAUBENDREHER POZIDRIVE



Nr.	Spezifikation	
18310	0 x 75 mm	12
18311	1 x 100 mm	12
18312	2 x 100 mm	12
18313	3 x 150 mm	6



SCHRAUBENDREHER POZIDRIVE, KURZ

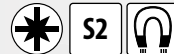

Nr.	Spezifikation	
18321	1 x 38 mm	12
18322	2 x 38 mm	12



SCHRAUBENDREHER TORX



Nr.	Spezifikation	
18350	T6	12
18351	T7	12
18352	T8	12
18353	T9	12
18354	T10	12
18355	T15	12
18356	T20	12
18357	T25	12
18358	T27	12
18359	T30	12
18360	T40	6



SCHRAUBENDREHER FÜR BITS + 7 BITS



Nr.	Spezifikation	
18425		10

- ⊖ S 5 - 6 mm
- ⊕ PH 1 · 2 · 3
- ⊗ T 15 · 20

NEW



SCHRAUBENDREHER UND BITS SET

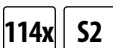

Nr.	Spezifikation	
18434		1

- schraubendreher für bits
- schraubendreher für mini-bits
- schraubendreher ⊖ 3x75, 5x75, 5x100, 6x100, 6x150, 8x150
- ⊕ 0x75, 1x75, 1x100, 2x100, 2x150
- ⊗ T10x75, T15x75
- ⊖ VDE 2.5x75mm, 4.0x100mm
- ⊖ Elektroprüfgerät
- ⊖ 2.5x40, 3.0x40mm
- ⊕ 00x40mm, 0x40mm,
- ⊗ T6x40mm, T7x40mm
- inbusschlüssel
- 1/16", 5/64", 3/32", 1/8", 5/32", 3/16", 7/32", 1/4"
- 1.5, 2.0, 2.5, 3.0, 4.0, 5.0, 5.5, 6.0mm
- kopf
- 6mm, 7mm, 8mm, 9mm, 10mm, 11mm
- bits
- ⊖ SL 3mm, 4mm, 4.5mm, 5mm, 5.5mm, 6mm, 7mm, 8mm
- ⊕ PH0, PH0, PH1, PH1, PH2, PH2, PH3, PH3
- ⊗ PZ0, PZ0, PZ1, PZ1, PZ2, PZ2, PZ3, PZ3,
- ⊗ T6, T8, T10, T15, T20, T25, T27, T30, T35, T40
- H1.5, H2.5, H3.0, H3.5, H4.0, H4.5, H5.0, H5.5, H6, H8
- ⊖ S0, S1, S2, S3
- mini-bits
- ⊖ SL 1.5mm, 2.0mm, 2.5mm, 3.0mm, 4.0mm
- ⊕ PH000, PH00, PH0, PH1
- ⊗ T4, T5, T6, T7, T8, T9, T10, T15, T20
- H0.7, H0.9



SCHRAUBENDREHER-SET

- ⊖ S 3x75 · 5x100 · 6,5x150 mm
- ⊕ PH 0 · 1 · 2 · 3



Nr. Spezifikation
18402 6



SCHRAUBENDREHER-SET

- ⊖ S 3x75 · 5x100 · 6x150 mm
- ⊕ PH 0 · 1 · 2



Nr. Spezifikation
18403 6



SCHRAUBENDREHER-SET

- ⊖ S 6,5x38 · 5,5x75 · 6,5x100 · 8x150 mm
2,5x50 · 3x50 mm
- ⊕ PH 2x38 · 1x75 · 2x100 · 3x150 mm
0x50 · 00x50 mm
- ⊛ T 5x50 · 6x50 · 7x50 · 8x50 · 9x50 · 10x50 mm



Nr. Spezifikation
18424 6



SCHRAUBENDREHER-SET

- ⊖ S 3x75 · 5x100 · 6,5x150 mm
- ⊛ PZ 0 · 1 · 2



Nr. Spezifikation
18404 6



TORX SCHRAUBENDREHER-SET

- ⊛ T 10 · 15 · 20 · 25 · 30



Nr. Spezifikation
18340 6



SCHRAUBENDREHER UND BITS SET.

- ⊖ S 3 x 75 · 4x100 · 5,5x125 · 6,5 x 150 mm
- ⊕ PH 1 x 100 · 2 x 100 mm
- adapter 1/4"

- Bits:
- ⊖ S 4 · 5 · 6 · 7
 - ⊕ PH 1 · 2 · 3
 - ⊛ PZ 1 · 2 · 3
 - ⊛ T 10 · 15 · 20 · 25 · 30
 - H 2 · 3 · 4 · 5 · 6



Nr. Spezifikation
18422 27 St. 6





VDE SCHRAUBENDREHER ELEKTRO FLACH



Nr.	Spezifikation		
18088	3 x 75 mm	S2	12
18089	4 x 100 mm	CrV	12
18090	5,5 x 125 mm	CrV	12
18091	6,5 x 150 mm	CrV	12
18092	8 x 175 mm	CrV	12



VDE SCHRAUBENDREHER ELEKTRO PHILIPS



Nr.	Spezifikation		
18080	PH 0 x 60 mm	S2	12
18081	PH 1 x 80 mm	CrV	12
18082	PH 2 x 100 mm	CrV	12
18083	PH 3 x 150 mm	CrV	12

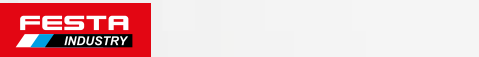

VDE SCHRAUBENDREHER ELEKTRO POZIDRIVE



Nr.	Spezifikation		
18084	PZ 0 x 60 mm	S2	12
18085	PZ 1 x 80 mm	CrV	12
18086	PZ 2 x 100 mm	CrV	12
18087	PZ 3 x 150 mm	CrV	12



SCHLAGSCHRAUBENDREHER, FLACH



Nr.	Spezifikation		
18062	5,5 x 100 mm		12
18063	7 x 125 mm		6
18064	8 x 150 mm		8
18065	10 x 175 mm		6
18066	10 x 200 mm		6
18067	10 x 250 mm		6



PHILIPS-SCHLAGSCHRAUBENDREHER



Nr.	Spezifikation		
18070	PH 1 x 80 mm		8
18071	PH 2 x 100 mm		12
18072	PH 3 x 150 mm		6



SCHLAGSCHRAUBENDREHER POZIDRIVE



Nr.	Spezifikation		
18075	PZ 1 x 80 mm		12
18076	PZ 2 x 100 mm		12
18077	PZ 3 x 150 mm		6



SCHLAGSCHRAUBENDREHER

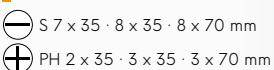

Nr.	Spezifikation		
18411			1



SCHLAGSCHRAUBENDREHER SET

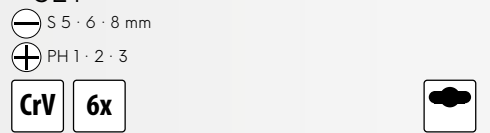
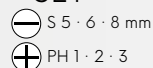

Nr.	Spezifikation		
18423			10



FESTA

SCHLITZSCHRAUBENZIEHER



Nr.	Spezifikation	
18101	3 x 75 mm	10
18102	4 x 100 mm	10
18103	5,5 x 100 mm	10
18104	5,5 x 125 mm	10
18105	6,5 x 100 mm	10
18106	6,5 x 125 mm	10
18107	8 x 160 mm	10
18108	10 x 160 mm	10



FESTA

SCHRAUBENDREHER UND BITS SET

- ⊖ S 3x75 · 4x75 · 6x100 · 8x150 mm
- ⊕ PH 1x75 · 2x100 mm
- adapter 1/4"

- Bits:
- ⊖ S 4 · 5 · 6 · 7 mm
 - ⊕ PH 1 · 2 · 3
 - ⊗ PZ 1 · 2 · 3
 - ⊛ T 10 · 15 · 20
 - ↔ ⊠ adapter



Nr.	Spezifikation	
18418		10



FESTA

SCHRAUBENDREHER PHILIPS



Nr.	Spezifikation	
18201	0 x 75 mm	10
18202	1 x 75 mm	10
18203	2 x 100 mm	10
18204	3 x 150 mm	10



FESTA

SCHRAUBENDREHER POZIDRIVE



Nr.	Spezifikation	
18301	0 x 75 mm	10
18302	1 x 75 mm	10
18303	2 x 100 mm	10
18304	3 x 150 mm	10



FESTA

SCHRAUBENDREHER FÜR BITS



Nr.	Spezifikation	
18110		12



FESTA

SCHRAUBENDREHER-SET

- ⊖ S 3x60 · 4x75 · 6x100 · 6x125 mm
- ⊕ PH 0x60 · 1x75 · 2x100 mm



Nr.	Spezifikation	
18400		10



FESTA

STECKSCHLÜSSEL
SCHRAUBENDREHER

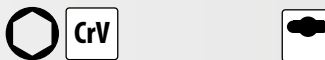

Nr.	Spezifikation	
18455	6 mm	12
18456	7 mm	12
18460	13 mm	12



FESTA

FLEXI-SCHRAUBENDREHER FÜR BITS

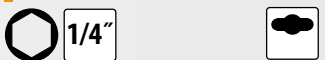

Nr.	Spezifikation	
18451		12



FESTA

SCHRAUBENDREHER-SET

- ⊖ S 3x60 · 6x100 · 6x125 mm
- ⊕ PH 1x75 · 2x100 mm



Nr.	Spezifikation	
18401		1

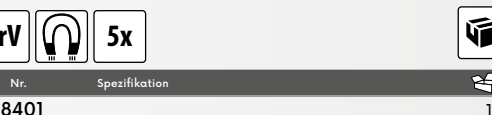

FESTA

FLEXI-SCHRAUBENDREHER
FÜR SCHLAUCHSCHELLEN

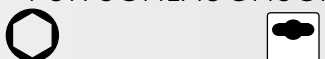

Nr.	Spezifikation	
18450	7 mm	6





SCHRAUBENDREHER FÜR BITS MIT RATSCH

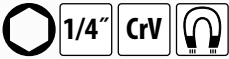

Nr. Spezifikation
18433 6



T-SCHRAUBENDREHER FÜR BITS MIT RATSCH

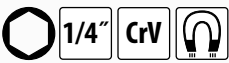

Nr. Spezifikation
18608 6



T-SCHRAUBENDREHER + 20 AUFSÄTZE

- S 3 · 4 · 5 · 6 · 8 mm
- PH 0 · 1 · 2 · 3
- adapter + 5 · 6 · 7 · 8 · 9 · 10 · 11 · 12 · 13 mm



Nr. Spezifikation
18420 5



SCHRAUBENDREHER MIT MINI-BITS

- S 1.5 · 2 · 2.5 · 3 · 3.5 mm
- PH 000 · 00 · 0 · 1
- PZ 0 · 1
- T 5 · 6 · 7 · 8 · 9 · 10 · 15 · 20
- H 0.9 · 1.3 · 2.0 · 2.5 · 3.0 · 4.0



Nr. Spezifikation
18431 6



RATSCHENSCHRAUBENDREHER MIT BITS

- 1/4" S 3 · 4 · 5 · 6 · 7 · 5 L
- PH 1 · 2 · 3 · 1 L · 2 L
- PZ 1 · 2 · 3 · 1 L · 2 L
- H 2 · 2.5 · 3 · 4 · 5 · 6
- T 10 · 15 · 20 · 25 · 27 · 30
- SQ 0 · 1 · 2 · 3
- 1/4" 5 · 6 · 7 · 8 · 9 · 10 · 11 · 12 · 13 mm



Nr. Spezifikation
18419 6



MINI-SCHRAUBENDREHE SET

- S 1,5x50 · 2x50 · 2,5x50 mm
- PH 000x50 · 00x50 · 0x50 mm



Nr. Spezifikation
18416 6



TORX-MINI-SCHRAUBENDREHER-SET

- T 4 · 5 · 6 · 7 · 8 · 9 · 10x50 mm



Nr. Spezifikation
18417 6



MINI-ELEKTRO-SCHRAUBENDREHER-SET

- S 2,4 · 3,0 mm
- PH 0 · 1
- T 6 · 8

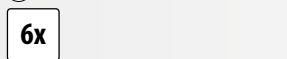

Nr. Spezifikation
18415 10



NEW



FESTO
ELEKTROPRÜFGERÄT

· AC - 110 V, 250 V



Nr.	Spezifikation	
18427		24

ELEKTROPRÜFGERÄT

DIN VDE 0680
73/23 EEC



Nr.	Spezifikation	
18426	0 - 250 V	1

FESTO
ÖFFNER



Nr.	Spezifikation	
18437		5

UHRMACHER-SCHRAUBENDREHER

⊖ S 1,4 · 2,0 · 2,4 · 3,0 mm

⊕ PH 0 · 1



6x HOBBY



Nr.	Spezifikation	
18408		10



GEWINKELTER
BITAUFSATZ 90°



Nr.	Spezifikation	
18910		25

BIT-RATSCH



Nr.	Spezifikation	
18435	93 mm	1



UHRMACHER-SCHRAUBENDREHER

⊖ S 1,0 · 1,2 · 1,4 · 1,8 · 2,4 · 3,0 mm

⊕ PH 00 · 0 · 1



11x HOBBY



Nr.	Spezifikation	
18409		48



BIT TORSION PH - 50 MM

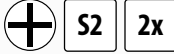

Nr.	Spezifikation	
18715	PH1 x 50 mm	1
18716	PH2 x 50 mm	1
18717	PH3 x 50 mm	1



BIT TORSION PZ - 50 MM



Nr.	Spezifikation	
18710	PZ1 x 50 mm	1
18711	PZ2 x 50 mm	1
18712	PZ3 x 50 mm	1



BIT TORSION T - 50 MM

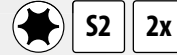

Nr.	Spezifikation	
18720	T10 x 50 mm	1
18721	T15 x 50 mm	1
18722	T20 x 50 mm	1
18723	T25 x 50 mm	1
18724	T30 x 50 mm	1
18725	T40 x 50 mm	1



BIT TORSION

- ⊕ PH 2 · 2
- ⊕ PZ 2
- ⊕ T 15 · 15 · 20 · 20 · 25 · 30 · 40

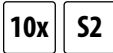

Nr.	Spezifikation	
18432		1



bits - Profi-Schraubensätze aus hochlegiertem Stahl S2

Produktionstechnologie

Kreuz- und Flachschaubensätze werden durch eine spezielle Präzisionsschmiedetechnik hergestellt. Dies ermöglicht eine hohe Formgenauigkeit bei gleichzeitig erhöhter Festigkeit im Vergleich zu bis zu 20 % bei bearbeiteten Bits. Nach dem Schmieden werden die Bits gehärtet, um eine optimale Härte und Hartnäckigkeit zu erreichen.

TiN-Schicht

die auf der Oberfläche der Schraubendreher Spitze aufgetragene Titannitridschicht maximiert die Oberflächenhärte, die Abriebfestigkeit und die Reibungseigenschaften, um ein Herausrutschen aus dem Biss zu verhindern.

Diamantkörner

an der Oberfläche der Spitze, sie „beißen“ sich buchstäblich in den Kopf der Schraube oder des Bolzens und halten den Bit im Eingriff für eine maximale Drehmomentübertragung. Sie sind die beste Garantie, im Eingriff zu bleiben. Am häufigsten wird der Schraubensatz beschädigt, wenn er aus dem Eingriff herausrutscht. Das Drehmoment wird dann auf die kleinste Fläche übertragen, die sich verformt.

Anti-Rutsch-Rillen

auf den Arbeitsflächen von geschmiedeten Schraubenspitzen sind sie ein weiterer sehr wirksamer Schutz gegen das Herausrutschen der Spitze aus dem Eingriff.

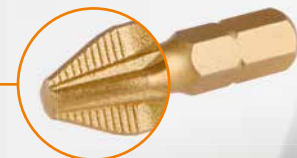



FESTA INDUSTRY

BIT PH

2x

Nr.	Spezifikation	
18632A	PH2 x 25 mm	1
18633A	PH3 x 25 mm	1

FESTA INDUSTRY

BIT PZ

2x **S2**

Nr.	Spezifikation	
18636A	PZ1 x 25 mm	1
18637A	PZ2 x 25 mm	1
18638A	PZ3 x 25 mm	1

FESTA INDUSTRY

BIT T

2x **S2**

Nr.	Spezifikation	
18827A	T20 x 25 mm	1
18828A	T25 x 25 mm	1
18830A	T30 x 25 mm	1
18831A	T40 x 25 mm	1

FESTA INDUSTRY

BIT PH DIAMANT

S2 **TiN** **DIN 3128**

MOQ 5

Nr.	Spezifikation	
18770	PH1 x 25 mm	5
18771	PH2 x 25 mm	5
18772	PH3 x 25 mm	5

FESTA INDUSTRY

BIT PZ DIAMANT

S2 **TiN** **DIN 3128**

MOQ 5

Nr.	Spezifikation	
18775	PZ1 x 25 mm	5
18776	PZ2 x 25 mm	5
18777	PZ3 x 25 mm	5

FESTA INDUSTRY

BIT S

S2

MOQ 5

Nr.	Spezifikation	
18620	S 3 x 25 mm	5
18621	S 4 x 25 mm	5
18623	S 5 x 25 mm	5
18625	S 6 x 25 mm	5
18627	S 7 x 25 mm	5
18628	S 8 x 25 mm	5

FESTA INDUSTRY

BIT PH

S2

MOQ 5

Nr.	Spezifikation	
18630	PH0 x 25 mm	5
18631	PH1 x 25 mm	5
18632	PH2 x 25 mm	5
18633	PH3 x 25 mm	5
18634	PH4 x 25 mm	5

FESTA INDUSTRY

BIT PZ

S2

MOQ 5

Nr.	Spezifikation	
18635	PZ0 x 25 mm	5
18636	PZ1 x 25 mm	5
18637	PZ2 x 25 mm	5
18638	PZ3 x 25 mm	5
18639	PZ4 x 25 mm	5

FESTA INDUSTRY

BIT PH

S2

MOQ 25

Nr.	Spezifikation	
18685	PH2 x 25 mm	25

FESTA INDUSTRY

BIT PZ

S2

MOQ 25

Nr.	Spezifikation	
18680	PZ2 x 25 mm	25

FESTA INDUSTRY

BIT PH

S2

MOQ 10

Nr.	Spezifikation	
18640	PH1 x 70 mm	10
18641	PH2 x 70 mm	10

FESTA INDUSTRY

BIT PZ

S2

MOQ 10

Nr.	Spezifikation	
18645	PZ1 x 70 mm	10
18646	PZ2 x 70 mm	10

FESTA INDUSTRY

BIT PH

S2 **TiN**

MOQ 5

Nr.	Spezifikation	
18760	PH0 x 25 mm	5
18761	PH1 x 25 mm	5
18762	PH2 x 25 mm	5
18763	PH3 x 25 mm	5
18764	PH4 x 25 mm	1

FESTA INDUSTRY

BIT PZ

S2 **TiN**

MOQ 5

Nr.	Spezifikation	
18765	PZ0 x 25 mm	5
18766	PZ1 x 25 mm	5
18767	PZ2 x 25 mm	5
18768	PZ3 x 25 mm	5
18769	PZ4 x 25 mm	5

FESTA INDUSTRY

BIT S

S2 **TiN**

MOQ 5

Nr.	Spezifikation	
18750	S 3 x 25 mm	5
18751	S 4 x 25 mm	5
18753	S 5 x 25 mm	5
18755	S 6 x 25 mm	5



BIT H



Nr.	Spezifikation	
18800	H 1,5 x 25 mm	5
18801	H 2,0 x 25 mm	5
18802	H 2,5 x 25 mm	5
18803	H 3,0 x 25 mm	5
18804	H 4,0 x 25 mm	5
18805	H 5,0 x 25 mm	5
18806	H 5,5 x 25 mm	5
18807	H 6,0 x 25 mm	5



BIT TTA



Nr.	Spezifikation	
18835	TTa 5 x 25 mm	10
18836	TTa 6 x 25 mm	5
18837	TTa 7 x 25 mm	5
18838	TTa 8 x 25 mm	5
18839	TTa 9 x 25 mm	5
18840	TTa 10 x 25 mm	5
18841	TTa 15 x 25 mm	5
18842	TTa 20 x 25 mm	5
18843	TTa 25 x 25 mm	5
18844	TTa 27 x 25 mm	5
18845	TTa 30 x 25 mm	5
18846	TTa 40 x 25 mm	5
18847	TTa 45 x 25 mm	5



BIT T



Nr.	Spezifikation	
18820	T5 x 25 mm	5
18821	T6 x 25 mm	5
18822	T7 x 25 mm	5
18823	T8 x 25 mm	5
18824	T9 x 25 mm	5
18825	T10 x 25 mm	5
18826	T15 x 25 mm	5
18827	T20 x 25 mm	5
18828	T25 x 25 mm	5
18829	T27 x 25 mm	5
18830	T30 x 25 mm	5
18831	T40 x 25 mm	5
18832	T45 x 25 mm	5



BIT HTA



Nr.	Spezifikation	
18810	HTa 1,5 x 25 mm	5
18811	HTa 2,0 x 25 mm	5
18812	HTa 2,5 x 25 mm	5
18813	HTa 3,0 x 25 mm	5
18814	HTa 4,0 x 25 mm	5
18815	HTa 5,0 x 25 mm	5
18816	HTa 5,5 x 25 mm	5
18817	HTa 6,0 x 25 mm	5



BIT SQ



Nr.	Spezifikation	
18850	SQ 0 x 25 mm	5
18851	SQ 1 x 25 mm	5
18852	SQ 2 x 25 mm	5
18853	SQ 3 x 25 mm	5



BIT T



Č.p.	specifikace	
17980	T30 x 35 mm	3
17981	T40 x 35 mm	3
17982	T45 x 35 mm	3
17983	T50 x 35 mm	3



BIT SD

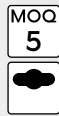
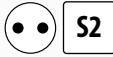

Nr.	Spezifikation	
18855	SD 6 x 25 mm	5
18856	SD 8 x 25 mm	5



BIT T



Nr.	Spezifikation	
17970	T20 x 75 mm	3
17971	T25 x 75 mm	3
17972	T30 x 75 mm	3
17973	T40 x 75 mm	3

Nr.	Spezifikation	
17974	T45 x 75 mm	3
17975	T50 x 75 mm	3
17976	T55 x 75 mm	3



BIT TS

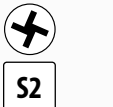

Nr.	Spezifikation	
18864	TS 4 x 25 mm	5
18865	TS 6 x 25 mm	5



BIT



Nr.	Spezifikation	
18866	5/32 x 25 mm	5
18867	3/16 x 25 mm	5



BIT TW



Nr.	Spezifikation	
18860	TW 1 x 25 mm	5
18861	TW 2 x 25 mm	5
18862	TW 3 x 25 mm	5
18863	TW 4 x 25 mm	5



BIT XZN



Nr.	Spezifikation	
18870	M4 x 25 mm	5
18871	M5 x 25 mm	5
18872	M6 x 25 mm	5
18873	M8 x 25 mm	5
18874	M10 x 25 mm	5



BIT



Nr.	Spezifikation	
18868	25 mm	5



BIT

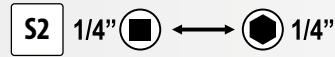

Nr.	Spezifikation	
18869	50 mm	5



FESTA
INDUSTRY

GIPSKARTON-BIT



Nr.	Spezifikation	
18795	PH 2 x 25 mm	24



FESTA
INDUSTRY

GIPSKARTON-BIT



Nr.	Spezifikation	
18796	PH 2 x 55 mm	24



FESTA
INDUSTRY

RATSCHENADAPTER
1/4" - BIT

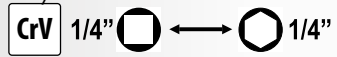

MOQ
5



Nr.	Spezifikation	
18619		5



FESTA
INDUSTRY

BITAUFSATZ



MOQ
5



Nr.	Spezifikation	
18600	1/4' x 60 mm	5



FESTA
INDUSTRY

BITAUFSATZ



Nr.	Spezifikation	
18601	1/4' x 60 mm	5



FESTA
INDUSTRY

BITAUFSATZ



MOQ
5



Nr.	Spezifikation	
18602	1/4' x 60 mm	5



FESTA
INDUSTRY

BITAUFSATZ



Nr.	Spezifikation	
18797	1/4' x 60 mm	1



FESTA
INDUSTRY

BITAUFSATZ



Nr.	Spezifikation	
18798	1/4' x 60 mm	1



FESTA
INDUSTRY

BITAUFSATZ



Nr.	Spezifikation	
18799	1/4' x 60 mm	1



FESTA
INDUSTRY

BITAUFSATZ



Č.p.	Specifikace	
18605	150 mm	25



FESTA

ADAPTER SDS + ZU BIT 1/4"



Č.p.	Specifikace	
20743	75 mm	1



BITAUFSATZ
MIT FÜHRUNG

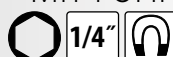

Nr.	Spezifikation	
18607	80 mm	25

FESTA

BITAUFSATZ



Nr.	Spezifikation	
18609	90mm	25



25

WEST BERG

**ADAPTER
BIT 1/4" - SDS +**

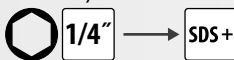

Nr.	Spezifikation	
20742		1



1

**FESTA
INDUSTRY**

**BIT- UND
ADAPTER-SET**

- 10x ⊕ 18630 PH0
- 10x ⊕ 18631 PH1
- 10x ⊕ 18632 PH2
- 10x ⊕ 18633 PH3
- 10x ⊕ 18635 PZ0
- 10x ⊕ 18636 PZ1
- 10x ⊕ 18637 PZ2
- 10x ⊕ 18638 PZ3
- 10x ⊕ 18761 PH1 TiN
- 10x ⊕ 18762 PH2 TiN
- 10x ⊕ 18763 PH3 TiN
- 10x ⊕ 18766 PZ1 TiN
- 10x ⊕ 18767 PZ2 TiN
- 10x ⊕ 18768 PZ3 TiN
- 10x ⊕ 18770 PH1 DIAMANT
- 10x ⊕ 18771 PH2 DIAMANT
- 10x ⊕ 18775 PZ1 DIAMANT
- 10x ⊕ 18776 PZ2 DIAMANT
- 10x ⊙ 18814 4,0HTa
- 10x ⊙ 18815 5,0HTa
- 10x ⊕ 18842 20TTa
- 10x ⊕ 18845 30TTa
- 10x ⊕ 18795 PH2 für Gipskarton
- 5x 18612 Adapter 1/4" 8mm
- 5x 18613 Adapter 1/4" 10mm
- 5x 18600 Magnetaufsatz 1/4" 60mm
- 5x 18601 magnetischer Schnellspannaufsatz 1/4" 60 mm
- 5x 18602 magnetischer Aufsatz, mit Anschlag 1/4" 65 mm

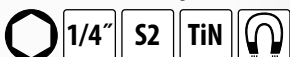

Nr.	Spezifikation	
18993		1



**FESTA
INDUSTRY**

BIT-SET

- 10x ⊕ 18631 PH1
- 10x ⊕ 18632 PH2
- 10x ⊕ 18633 PH3
- 10x ⊕ 18636 PZ1
- 10x ⊕ 18637 PZ2
- 10x ⊕ 18638 PZ3
- 10x ⊕ 18761 PH1 TiN
- 10x ⊕ 18762 PH2 TiN
- 10x ⊕ 18763 PH3 TiN
- 10x ⊕ 18766 PZ1 TiN
- 10x ⊕ 18767 PZ2 TiN
- 10x ⊕ 18768 PZ3 TiN
- 10x ⊙ 18804 H 4
- 10x ⊙ 18805 H 5
- 10x ⊙ 18825 T 10
- 10x ⊙ 18826 T 15
- 10x ⊙ 18827 T 20
- 10x ⊙ 18828 T 25
- 10x ⊙ 18830 T 30
- 10x ⊙ 18831 T 40

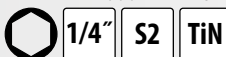

Nr.	Spezifikation	
18994		1



**FESTA
INDUSTRY**

ADAPTER

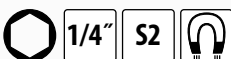

Nr.	Spezifikation	
18610	6 mm	5
18611	7 mm	5
18612	8 mm	5



Nr.	Spezifikation	
18613	10 mm	5
18614	12 mm	5
18615	13 mm	5

**FESTA
INDUSTRY**

ADAPTER

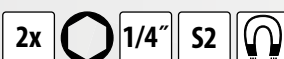

Nr.	Spezifikation	
18610A	6 mm	5
18611A	7 mm	5
18612A	8 mm	5



Nr.	Spezifikation	
18613A	10 mm	5
18614A	12 mm	5
18615A	13 mm	5

FESTA

**ADAPTER
SET**

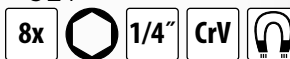

Nr.	Spezifikation	
18618	6, 7, 8, 9, 10, 11, 12, 13 mm	12



12





FESTA

BIT-SATZ

- 25 mm S 3 · 4 · 5 · 6
- PH 0 · 1 · 2 · 3
- PZ 0 · 1 · 2 · 3
- H 3 · 4 · 5 · 6
- T 10 · 15 · 20 · 25 · 27 · 30 · 40
- TTa 10 · 15 · 20 · 25 · 27 · 30 · 40

Bithalter

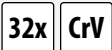

Nr.	Spezifikation
18908	1



FESTA

BIT-SATZ

- S 3 · 4 · 5 · 6
- PH 1 · 2 · 3
- PZ 1 · 2 · 3
- H 3 · 4 · 5 · 6
- T 10 · 15 · 20 · 25 · 27 · 30 · 40
- TTa 10 · 15 · 20 · 25 · 27 · 30 · 40

· magnetischer Bit-Schnellspannaufsatz

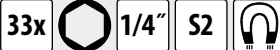

Nr.	Spezifikation
18905	10



FESTA

BIT-SATZ

- S 4 · 5 · 6
- PH 1 · 2 · 3
- PZ 1 · 2 · 3
- H 3 · 4 · 5 · 6
- T 10 · 15 · 20 · 25 · 27 · 30 · 40
- TTa 10 · 15 · 20 · 25 · 27 · 30 · 40

· magnetischer Bit-Schnellspannaufsatz

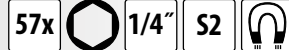

Nr.	Spezifikation
18906	6

FESTA

BIT-SATZ

- HTa 2 · 2.5 · 3 · 4 · 5 · 6
5/32" · 9/64" · 1/8"
7/64" · 3/32" · 5/64"
- SD 4 · 6 · 8 · 10
- TS 6 · 8 · 10
- TW 1 · 2 · 3 · 4
- TTa 8 · 10 · 15 · 20 · 25 · 27 · 30 · 35 · 40

· magnetischer Bitaufsatz

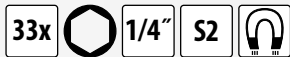

Nr.	Spezifikation
18900	10

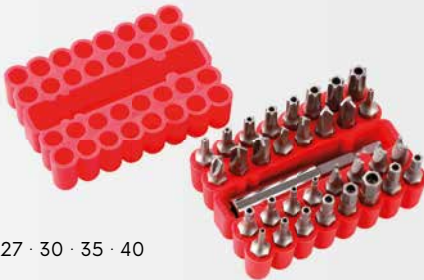

FESTA

BIT-SATZ

- S 3 · 4 · 4.5 · 5 · 5.5 · 6 · 6.5 · 7 · 8
- PH 0 · 1 · 2 · 3
- PZ 0 · 1 · 2 · 3
- Q 0 · 1 · 2 · 3
- T 8 · 10 · 15 · 20 · 25 · 27 · 30 · 40 · 45
- TTa 8 · 10 · 15 · 20 · 25 · 27 · 30 · 35 · 40
- H 1.5 · 2 · 2.5 · 3 · 4 · 5 · 5.5 · 6 · 8 mm
1/16" · 5/64" · 3/32" · 7/64" · 1/8" · 9/64"
5/32" · 3/16" · 7/32" · 1/4"
- HTa 2 · 2.5 · 3 · 4 · 5 · 6 mm
5/64" · 3/32" · 7/64" · 1/8" · 9/64" · 5/32"
- SD 4 · 6 · 8 · 10
- TS 6 · 8 · 10
- TW 1 · 2 · 3 · 4
- 2-wing 1 · 2 · 3
- ZN 5 · 6 · 8

magnetischer Bitaufsatz.

· „Y“ Aufsatz

1/4" DR Schraubendreheraufsatz

1/4" Bit Adapter: 25 mm, 50 mm



Nr.	Spezifikation
18909	24

FESTA

BIT-SATZ

- S 3 · 4 · 5 · 6 · 7
- PH 0 · 1 · 2 · 3
- PZ 1 · 2 · 3
- H 2 · 2.5 · 3 · 4 · 5 · 6
- T 10 · 15 · 20 · 25 · 30 · 40

· magnetischer Bitaufsatz

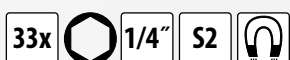

Nr.	Spezifikation
18901	10



BIT-SET

- ⊖ S 4 · 5 · 6 · 7
- ⊕ PH 1 · 2 · 3
- ✱ PZ 1 · 2 · 3
- H 4 · 5 · 6
- ⊛ T 10 · 15 · 20 · 25
- SQ 1 · 2 · 3

20x S2



BIT-SET

- ⊖ S 4 · 5 · 6 · 7
- ⊕ PH 1 · 2 · 3
- ✱ PZ 1 · 2 · 3

10x CrV TiN



BIT-SET

- ⊖ S 3 · 5 · 7
 - ⊕ PH 1 · 2 · 3
- magnetischer Bitaufsatz

7x



HOBBY



Nr.	Spezifikation	10
18907		

Nr.	Spezifikation	10
18440		

Nr.	Spezifikation	20
18430		



BITS UND AUFSÄTZE IM SET

- ⊖ S 3 · 3,5 · 4 · 5,5
- ⊕ PH 0 · 1 · 2 · 3
- ✱ PZ 0 · 1 · 2 · 3
- H 3 · 4
- ⊛ T 10 · 15 · 20 · 25 · 27 · 30
- 1/4" 4 · 4,5 · 5 · 5,5 · 6 · 7 · 8 · 9 · 10 · 11 · 13

1/4"-Schraubendreheraufsatz
magnetischer Bitaufsatz.

CrV 1/4"

40x



Nr.	Spezifikation	10
18915		

WERKZEUGSATZ

- ⊖ S 5 · 6 mm
- ⊕ PH 1 · 2
- H 3 · 4 · 5 · 6
- ⊛ T 15 · 20 · 25 · 30
- 1/4" 4 · 5 · 6 · 7 · 8 · 9 · 10 · 12 · 13 mm

75 mm 1/4"
 1/4" ↔ 1/4"

1/4" CrV

23x



Nr.	Spezifikation	10
18421		



- 1/2", 1/4"
- 1/4" · 4-5-6-7-8-9mm
- 1/2" · 10-12-13-14-17-19mm
- 1/4" · 4-4.5-5-5.5-6-7-8-9-10-11-12-13-14mm
- 1/2" · 12-13-14-15-16-17-18-19-20-21-22-24mm
- 1/2", 1/4"
- 1/4" 1/4"
- 1/4" · 150mm
- 1/2" · 254mm
- 1/2", 1/4"
- 1/2" · 16-21mm
- 1/4" · 150mm
- 1/2" · E10-E12-E14-E16-E18-E20-E22-E24
- 1/4" S 3 · 4 · 5 · 6
- 1/4" PH 0 · 1 · 2
- 1/4" PZ 0 · 1 · 2
- 1/4"
- 1/4" · S 4 · 5,5 · 6,5
- 1/4" PH 1 · 2 · 3
- 1/4" PZ 2 · 3
- 1/4" H 3 · 4 · 5 · 6
- 1/4" T 8 · 10 · 15 · 20 · 25
- 1/4" TTa 10 · 15 · 20 · 25 · 40
- 2 · 2,5 · 3 · 4 · 5 · 6 · 7 · 8 · 10mm
- 8-9-10-11-12-13-14-15-16-17-18-19mm
- S 4x100 · 6,5x150
- PH 2x100 · 3x150
- 180mm
- 160mm
- 160mm
- 250mm
- 300g

FESTA

WERKZEUGSATZ

122x CrV S2 1/4" 1/2" 72T

Nr. 17238 Spezifikation 122 St.



1



WERKZEUGSATZ

- 160 mm
- 160 mm
- 300 g
- 1/4" 45T
- 4 · 5 · 6 · 7 · 8 · 9 · 10 · 11 · 12 · 13 mm
- 1/4" 75 mm
- 1,5 · 2 · 2,5 · 3 · 4 · 5 · 6 · 8 · 10 mm
- S 3 · 4 · 5 · 6 mm
- PH 0 · 1 · 2 · 3
- PZ 0 · 1 · 2 · 3
- T 10 · 15 · 20 · 25
- H 3 · 4 · 5 · 6
- S 5x100 mm
- PH 1x100 · 2x100 mm
- S 2,5x50 mm
- PH 00x50 · 0x50 mm
- AC 100-250 V
- 200 mm max. 22 mm
- 10x11 · 12x13 · 14x15 · 16x17 mm
- 18 mm
- 2 m 13 mm

WERKZEUGSATZ

- 120mm
- 125mm
- 115mm
- 150mm max. 19mm
- 9mm
-
-
-
-
-
-
- 1/4" 160mm
- 5 · 6 · 7 · 8 · 9 · 10 · 11 mm
- 1/4"
- 1/4"
- S 4 · 6 mm
- PH 1 · 2 · 3
- PZ 1 · 2
- H 4 · 5 · 6

WERKZEUGSATZ

- 1/4" 5 · 6 · 7 · 8 · 9 · 10 · 11 · 12 mm
- 1/4"
- 1/4"
- AC 230 V
- PH 0, SL 3
- 9x 1,5-10 mm
- 160 mm
- S 3 · 4 · 5 · 6 mm
- PH 0 · 1 · 2 · 3
- H 4 · 5
-
- PH 2x100, S 6x100
- 18 mm
- 1 m
- 300 g

60x



35x



39x



Nr. 17259 Spezifikation

5

Nr. 17260 Spezifikation

10

Nr. 17247 Spezifikation

10

FESTA

10 years
garantie



- Industrie- und Dienstleistungsanwendungen
- Hochwertiger Chrom-Vanadium-Stahl
- Ratsche mit 72 geschliffenen Zähnen für präzises Arbeiten
- Alle Komponenten entsprechen der DIN-Norm
- Gerändelte Köpfe für besseren Halt
- Robuster Koffer mit Metallschlössern und Metallscharnieren



FESTA

GOLA-SET

- 1/2", 1/4", 3/8"
- 1/4" · 4-5-6-7-8-9-10mm
- 3/8" · 10-11-12-13-14-15mm
- 1/2" · 16-17-18-19-22mm
- 1/4" · 4-4.5-5-5.5-6-7-8-9-10-11-12-13-14mm
- 3/8" · 10-11-12-13-14-15-16-17-18-19mm
- 1/2" · 10-11-12-13-14-15-16-17-18-19-20-21-22-24-27-30-32mm
- 1/4" · E4-E5-E6-E7-E8
- 3/8" · E10-E11-E12-E14-E16-E18
- 1/2" · E20-E24
- 1/2" · 24x
- 1/4" · 20x
- 1/4" · 30x
- 1/4" · 50 mm, 100 mm
- 1/2" · 125 mm, 250 mm
- 3/8" · 150 mm
- 1/2" · 16-21mm
- 3/8" · 18mm
- 1/2", 1/4", 3/8" bit holder
- 1/2", 1/4", 3/8"
- 1/4" · 150mm
- 1/4" · 115mm
- Inbus 7X

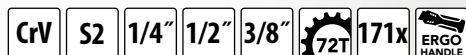

10 years
garantie



Nr. 17237 Spezifikation 2



FESTA

GOLA-SET

- 1/2" · 72T
- 1/2" · 125 mm
- 1/2" · 10-11-12-13-14-15-17-19-22-24 mm

10 years guarantee



Č.p. specifikace 17245 15



FESTA

GOLA-SET

- 1/2" · 72T
- 1/2" · 125 mm
- 1/2" · 10-11-12-13-14-15-17-19-22-24 mm

10 years guarantee



Č.p. specifikace 17229 8



FESTA

GOLA-SET

- 1/2" · 72 T
- 1/2" · 75, 125 mm
- 1/2"
- 1/2" · 10-11-12-13-14-15-16-17-18-19-22-24 mm
- 1/2" · 17mm, 19mm
- 3 way adapter
- 16mm, 21mm

10 years guarantee



Č.p. specifikace 17230 4



FESTA

GOLA-SET

- 1/4" · 72 T
- 1/4" · 50, 100 mm
- 1/4"
- 1/4" · 4-5-5,5-6-7-8-10-11-12-13 mm
- 1/4" · 6-7-8-10-12-13 mm
- 3 way adapter
- 4 x
- 11x
- 1x

10 years guarantee

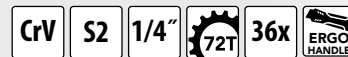

Č.p. specifikace 17231 10



FESTA

GOLA-SET

- 1/4"
- 1/4"
- 1/4" · 4-4,5-5-5,5-6-7-8-9-10-11-12-13-14 mm
- 1/4" · 50 mm, 100 mm
- 1/4"
- 1/4"
- 21 x
- 1/4"
- L 1/4"

10 years guarantee



Č.p. specifikace 17233 10



FESTA

GOLA-SET

- 1/2", 1/4" · 72T
- 1/4"
- 16 mm, 21 mm
- 1/4" · 10-11-12-13-14-15-16-17-18-19-20-21-22-23-24-27 mm
- 1/4" · 100 mm
- 1/2" · 125 mm, 250 mm
- 1/2"
- 1x
- 1/4" · 4-5-5,5-6-7-8-10-11-12-13 mm
- 33 x



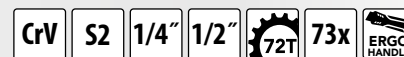







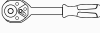
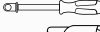



10 years guarantee



Č.p. specifikace 17234 4

FESTA

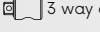
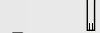
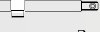
GOLA-SET

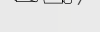
-  1/2", 1/4" · 72T
-  1/4"
-  16 mm, 21 mm
-  1/4" · 4 -4,5-5-5,5-6-7-8-9-10-11-12-13-14 mm
-  1/2" · 10-11-12-13-14-15-16-17-18-19-20-21-22-23-24-27-30-32 mm
-  1/4" · 6-7-8-9-10-11-12-13 mm
-  1/2" · 14-15-17-19 mm
-  1/4" · 50 mm, 100 mm
-  1/2" · 125 mm, 250 mm
-  1/4"
-  5/16" bit holder
-  17x
-  15x
-  3 way adapter
-  3 x
-  1/4"
-  L 1/4"
-  1/2", 1/4"

CrV S2 1/4" 1/2" 72T 94x ERGO HANDLE













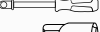

10 years guarantee

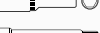

Č.p.	specifikace
17235	4

FESTA

GOLA-SET

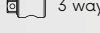
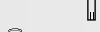
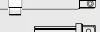
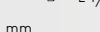
-  1/2", 1/4" · 72T
-  150 mm
-  16 mm, 21 mm
-  1/4" · 4 -4,5-5-5,5-6-7-8-9-10-11-12-13-14 mm
-  1/2" · 10-11-12-13-14-15-16-17-18-19-20-21-22-24-27-30-32 mm
-  1/4" · 6-7-8-9-10-11-12-13 mm
-  1/2" · 14-15-17-19-22 mm
-  1/4" · 50 mm, 100 mm
-  1/2" · 125 mm, 250 mm
-  E · 4-5-6-7-8-10-11-12-14-16-18-20-24-27-30-32 mm
-  1/2", 1/4"
-  5/16" bit holder
-  18 x
-  17 x
-  3 way adapter
-  4 x
-  1/4"
-  L 1/4"

CrV S2 1/4" 1/2" 72T 110x ERGO HANDLE



















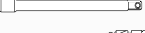







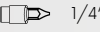

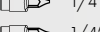
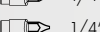
10 years guarantee

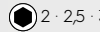

Č.p.	specifikace
17236	4

FESTA

WERKZEUGSATZ

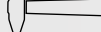
-  1/2", 1/4"
-  1/4" · 4-5-6-7-8-9mm
-  1/2" · 10-12-13-14-17-19mm
-  1/4" · 4-4,5-5-5,5-6-7-8-9-10-11-12-13-14mm
-  1/2" · 12-13-14-15-16-17-18-19-20-21-22-24mm
-  1/2", 1/4"
-  1/4" · 150mm
-  1/2" · 254mm
-  1/2", 1/4"
-  1/2" · 16-21mm
-  1/4" · 150mm
-  1/2" · E10-E12-E14-E16-E18-E20-E22-E24
-  1/4" · S 3 · 4 · 5 · 6
-  1/4" · PH 0 · 1 · 2
-  1/4" · PZ 0 · 1 · 2
-  1/4" · S 4 · 5,5 · 6,5
-  1/4" · PH 1 · 2 · 3
-  1/4" · PZ 2 · 3
-  1/4" · H 3 · 4 · 5 · 6
-  1/4" · T 8 · 10 · 15 · 20 · 25
-  1/4" · TTα 10 · 15 · 20 · 25 · 40
-  2 · 2,5 · 3 · 4 · 5 · 6 · 7 · 8 · 10mm
-  8-9-10-11-12-13-14-15-16-17-18-19mm
-  S 4x100 · 6,5x150
-  PH 2x100 · 3x150
-  180mm
-  160mm
-  160mm
-  250mm
-  300g

CrV S2 1/4" 1/2" 72T 122x ERGO HANDLE



Č.p.	specifikace
17238	122 ks 1



FESTA



FESTA



- Der Griff ist aus Chromvanadium-Stahl höchster Qualität gefertigt
- Ratsche mit 72 geschliffenen Zähnen für präzises Arbeiten
- Hochwertiger, ergonomischer Zwei-Komponenten-Griff aus weichem TPE-Gummi
- QUICK RELEASE SYSTEM für einfachen und schnellen Wechsel der Köpfe



FESTA

RATSCHEN



Č.p.	specifikace	délka	
17297	1/4"	155 mm	6
17298	3/8"	210 mm	5
17299	1/2"	255 mm	4

FESTA

RATSCHEN



Č.p.	specifikace	délka	
17240	1/4"	155 mm	10
17241	3/8"	200 mm	10
17242	1/2"	250 mm	5

FESTA

RATSCHEN



Č.p.	specifikace	délka	
17294	1/4"	155 mm	6
17295	3/8"	205 mm	10
17296	1/2"	255 mm	4

FESTA

DREHRATSCHEN 1/4"



Č.p.	specifikace	
17292	1/4"	1

RATSCHEN

HOBBY



Č.p.	specifikace	
17243	1/4" 43T	25
17244	1/2" 39T	25

FESTA

SCHRAUBENDREHER FÜR KÖPFE

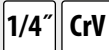

Č.p.	specifikace	
18603	1/4" 150 mm	10



FESTA
KOPF 1/4"



Č.p.	specifikace	
17820	4 mm • 25 mm	10
17821	4,5 mm • 25 mm	10
17822	5 mm • 25 mm	10
17823	5,5 mm • 25 mm	10
17824	6 mm • 25 mm	10
17825	7 mm • 25 mm	10
17826	8 mm • 25 mm	10
17827	9 mm • 25 mm	10
17828	10 mm • 25 mm	10
17829	11 mm • 25 mm	10
17830	12 mm • 25 mm	10
17831	13 mm • 25 mm	10
17832	14 mm • 25 mm	10



FESTA
KOPF 1/2"

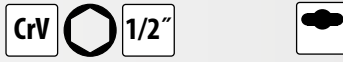

Č.p.	specifikace	
17308	8 mm • 38 mm	10
17309	9 mm • 38 mm	10
17310	10 mm • 38 mm	10
17311	11 mm • 38 mm	10
17312	12 mm • 38 mm	10
17313	13 mm • 38 mm	10
17314	14 mm • 38 mm	10
17315	15 mm • 38 mm	10
17316	16 mm • 38 mm	10
17317	17 mm • 38 mm	10
17318	18 mm • 38 mm	10
17319	19 mm • 38 mm	10
17320	20 mm • 38 mm	10
17321	21 mm • 38 mm	10
17322	22 mm • 38 mm	10
17324	24 mm • 38 mm	10
17327	27 mm • 42 mm	20
17330	30 mm • 42 mm	25
17332	32 mm • 42 mm	20
17333	34 mm • 42 mm	20
17334	36 mm • 42 mm	20



FESTA
KOPF 3/4"

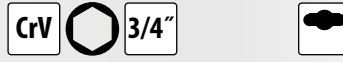

Č.p.	specifikace	
17835	17 mm • 48 mm	10
17836	18 mm • 48 mm	10
17837	19 mm • 48 mm	10
17838	21 mm • 48 mm	10
17839	22 mm • 48 mm	10
17840	24 mm • 48 mm	10
17841	26 mm • 48 mm	10
17842	27 mm • 52 mm	10
17843	28 mm • 52 mm	10
17844	30 mm • 52 mm	10
17845	32 mm • 52 mm	10
17846	33 mm • 55 mm	10
17847	36 mm • 60 mm	10
17848	38 mm • 60 mm	10
17849	41 mm • 65 mm	10
17850	46 mm • 65 mm	10
17851	50 mm • 70 mm	10
17852	55 mm • 75 mm	10
17853	60 mm • 78 mm	10
17854	65 mm • 82 mm	10
17855	70 mm • 82 mm	10
17856	75 mm • 88 mm	10



FESTA
MULTILOCK
KOPF 1/2"

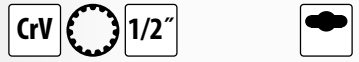

Č.p.	specifikace	
17910	8 mm • 38 mm	10
17914	12 mm • 38 mm	10
17916	14 mm • 38 mm	10
17922	21 mm • 38 mm	10
17924	24 mm • 38 mm	10
17926	30 mm • 38 mm	10



FESTA
VERLÄNGERTER
KOPF 1/4"



Č.p.	specifikace	
17860	4 mm • 50 mm	10
17861	5 mm • 50 mm	10
17862	6 mm • 50 mm	10
17863	7 mm • 50 mm	10
17864	8 mm • 50 mm	10
17865	9 mm • 50 mm	10
17866	10 mm • 50 mm	10
17867	11 mm • 50 mm	10
17868	12 mm • 50 mm	10
17869	13 mm • 50 mm	10
17870	14 mm • 50 mm	10



FESTA
VERLÄNGERTER
KOPF 1/2"



Č.p.	specifikace	
17871	10 mm • 70 mm	10
17872	11 mm • 70 mm	10
17873	12 mm • 70 mm	10
17874	13 mm • 70 mm	10
17875	14 mm • 70 mm	10
17876	15 mm • 70 mm	10
17877	16 mm • 70 mm	10
17878	17 mm • 70 mm	10
17879	18 mm • 70 mm	10
17880	19 mm • 70 mm	10
17881	20 mm • 70 mm	10
17882	21 mm • 70 mm	10
17883	22 mm • 70 mm	10
17884	23 mm • 70 mm	10
17885	24 mm • 70 mm	10
17886	25 mm • 70 mm	10
17887	26 mm • 70 mm	10
17888	27 mm • 70 mm	10
17889	28 mm • 70 mm	10
17890	30 mm • 70 mm	10
17891	32 mm • 70 mm	10
17892	34 mm • 70 mm	10



FESTA
TORX
KOPF 1/2"



Č.p.	specifikace	
17943	E22	10
17944	E24	10



FESTA
TORX
KOPF 1/4"

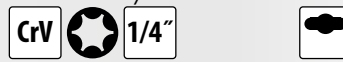

Č.p.	specifikace	
17930	E4	10
17934	E8	10
17935	E10	10



FESTA
MULTILOCK
KOPF 1/4"



Č.p.	specifikace	
17895	4 mm • 25 mm	10
17896	4,5 mm • 25 mm	10
17897	5 mm • 25 mm	10
17898	5,5 mm • 25 mm	10
17904	11 mm • 25 mm	10
17905	12 mm • 25 mm	10
17907	14 mm • 25 mm	10





FESTA

1/4"-SCHRAUBEN-DREHERAUFSATZ

CrV	S2	—	1/4"	
Č.p.	specifikace			
18920	S 4 mm	10		
18921	S 5,5 mm	10		
18922	S 7 mm	10		



FESTA

1/4"-SCHRAUBEN-DREHERAUFSATZ

CrV	S2	+	1/4"	
Č.p.	specifikace			
18925	PH 1	10		
18926	PH 2	10		
18927	PH 3	10		



FESTA

1/4"-SCHRAUBEN-DREHERAUFSATZ

CrV	S2	✳	1/4"	
Č.p.	specifikace			
18928	PZ 0	10		
18929	PZ 1	10		
18930	PZ 2	10		
18931	PZ 3	10		



FESTA

1/2"-SCHRAUBEN-DREHERAUFSATZ

CrV	S2	★	1/2"	
Č.p.	specifikace			
18954	T 10	10		
18955	T 15	10		
18956	T 20	10		
18960	T 40	10		
18961	T 45	10		
18963	T 55	10		



FESTA

1/4"-SCHRAUBEN-DREHERAUFSATZ

CrV	S2	★	1/4"	
Č.p.	specifikace			
18948	T 5	10		
18950	T 8	10		
18951	T 10	10		



FESTA

1/4"-SCHRAUBEN-DREHERAUFSATZ

CrV	S2	⬡	1/4"	
Č.p.	specifikace			
18934	3 mm	10		
18939	8 mm	10		



FESTA

1/2"-SCHRAUBEN-DREHERAUFSATZ

CrV	S2	⬡	1/2"	
Č.p.	specifikace			
18971	M 16	10		



FESTA

REITER AUF EINEM „T“-STRAHL

CrV		
Č.p.	specifikace	
17420	1/4"	1
17421	1/2"	1
17422	3/4"	1



FESTA

ADAPTER

CrV		
Č.p.	specifikace	
17410	A - 1/4" B - 3/8"	10
17411	A - 3/8" B - 1/4"	10
17412	A - 3/8" B - 1/2"	10
17413	A - 1/2" B - 3/8"	10
17414	A - 1/2" B - 3/4"	10
17415	A - 3/4" B - 1/2"	10
17416	A - 1/4" B - 1/2"	10



FESTA

VERLÄNGERUNG-STÜCK

CrV		
Č.p.	specifikace	
17390	1/4" • 50 mm	1
17391	1/4" • 100 mm	1
17392	1/4" • 150 mm	1
17393	1/2" • 75 mm	1
17394	1/2" • 125 mm	1
17395	1/2" • 250 mm	1
17396	3/4" • 100 mm	1
17397	3/4" • 200 mm	1
17398	3/4" • 400 mm	1



FESTA

KARDAN

CrV		
Č.p.	specifikace	
17405	1/4" • 39 mm	10
17406	1/2" • 71 mm	10
17407	3/4" • 105 mm	10

FESTA

"T"-STRAHL

CrV		
Č.p.	specifikace	
17382	1/4" • 115 mm	1
17383	3/8" • 190 mm	1
17384	1/2" • 250 mm	1
17385	3/4" • 460 mm	1
17386	1" • 640 mm	1



FESTA

"T" AUFSATZ VERLÄNGERT MIT GELENK

CrV		
Č.p.	specifikace	
17401	1/4" • 250 mm	1
17402	1/2" • 400 mm	1





FESTA

GELENST.TRAHL - RUCK

CrV

Nr.	Spezifikation	
17380	1/2" • 350 mm	1
17381	3/4" • 500 mm	1



FESTA

GRIFF GEBOGE

CrV 1/2"

Nr.	Spezifikation	
17427	1/2" • 60 x 320 mm	1



FESTA

FLEXIBLER AUFSATZ

CrV 1/4"

Nr.	Spezifikation	
17400	1/4" • 150 mm	1

Stahlberg

RATSCHENADAPTER
1/4" - BIT

CrV

1/4" ↔ 1/4"

Nr.	Spezifikation	
18619		5



MOQ 5



UNIVERSALKOPF

CrV 1/2"

Nr.	Spezifikation	
17812	10 - 19 mm	1



1/4"



3/8"



UNIVERSALKOPF

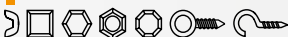

CrV 3/8"

Nr.	Spezifikation	
17810	für Schrauben 7 - 19mm - 52mm x ø26mm	1



1/4"



1/2"



UNIVERSALKOPF

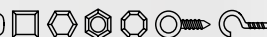

CrV 1/2"

Nr.	Spezifikation	
17811	für Schrauben 11 - 32mm - 83mm x ø43mm	5

DRIVELOCK-STECKKOPF-SET

4-5-5,5-6-7-8-9-10-11-12-13 mm

CrV 1/4" 12x

Č.p.	specifikace	
17250		10



TORX-STECKKOPF-SET

1/4" • 5-6-7-8-10

1/2" • 12-14-16-18

CrV 1/2" 1/4" 9x

Č.p.	specifikace	
17255		4



CrV 1/4" 3x

Nr.	Spezifikation	
18604	1/4", 3/8", 1/2"	10

FESTA

SCHRAUBENSCHLÜSSEL
FÜR HEIZKÖRPERMONTAGE

CrV 1/2"

Nr.	Spezifikation	
17455	für Ratsche 1/2"	10



NEW



FESTA

**T-TORX+INBUS
SCHLÜSSEL - SET**

- H 2.5 · 3 · 4 · 5 · 6 · 8 · 10 mm
- ★ T 10 · 15 · 20 · 25 · 30 · 40 · 45

14x CrV



Nr.	Spezifikation	
18501		1

FESTA

**T-
INBUSSCHLÜSSEL
SET**

- 2 mm
- 2,5 mm
- 3 mm
- 4 mm
- 5 mm
- 6 mm
- 7 mm
- 8 mm
- 10 mm

9x **CrV**



Nr.	Spezifikation	
18494		6



FESTA

**T - TORX-
SCHLÜSSEL**

★ CrV



Nr.	Spezifikation		Nr.	Spezifikation	
17350	T 7	10	17357	T 27	10
17351	T 8	10	17359	T 40	10
17352	T 9	10	17361	T 50	10
17353	T 10	10			

FESTA

**T-TORX-
SCHLÜSSEL -
SET**

- T 10
- T 15
- T 20
- T 25
- T 27
- T 30
- T 40
- T 45
- T 50

9x **CrV**



Nr.	Spezifikation	
18495		6



FESTA

**INBUSSCHLÜSSEL
STANDARD**

DIN 911 **CrV**



Č.p.	specifikace	
18567	27 mm 100 x 250 mm	1
18572	32 mm 125 x 315 mm	1

FESTA

**INBUSSCHLÜSSEL
VERLÄNGERT**

CrV



Č.p.	specifikace	
18510	1,5 mm 14 x 74 mm	1
18511	2 mm 16 x 81 mm	1
18512	2,5 mm 18 x 88 mm	1
18513	3 mm 23 x 108 mm	1
18514	4 mm 24 x 107 mm	1
18515	5 mm 23 x 118 mm	1
18516	6 mm 32 x 135 mm	1
18518	8 mm 36 x 153 mm	1
18519	9 mm 38 x 155 mm	1
18520	10 mm 40 x 168 mm	1
18521	11 mm 40 x 230 mm	1
18522	12 mm 45 x 237 mm	1
18523	13 mm 45 x 260 mm	1
18524	14 mm 55 x 265 mm	1
18527	17 mm 60 x 298 mm	1

FESTA

**INBUSSCHLÜSSEL MIT
KOPFSTÜCK VERLÄNGERT**

CrV



Č.p.	specifikace	
18575	1,5 mm 15 x 75 mm	1
18576	2 mm 17 x 81 mm	1
18577	2,5 mm 18 x 87 mm	1
18578	3 mm 20 x 96 mm	1
18579	4 mm 24 x 107 mm	1
18580	5 mm 30 x 120 mm	1
18581	6 mm 33 x 136 mm	1
18582	7 mm 34 x 144 mm	1
18583	8 mm 36 x 153 mm	1
18584	9 mm 38 x 155 mm	1
18585	10 mm 40 x 168 mm	1
18587	12 mm 45 x 237 mm	1
18588	13 mm 45 x 210 mm	1
18589	14 mm 55 x 265 mm	1
18593	17 mm 60 x 298 mm	1

FESTA

TORX-SCHLÜSSEL

★ CrV



Č.p.	specifikace	
18476	T45	1

FESTA

SET
INBUSSCHLÜSSEL

- H 1,5 mm
- H 2 mm
- H 2,5 mm
- H 3 mm
- H 4 mm
- H 5 mm
- H 6 mm
- H 8 mm
- H 10 mm



Nr. Spezifikation
18496



5

FESTA

SET INBUSSCHLÜSSEL
MIT KOPFSTÜCK

- H 1,5 mm
- H 2 mm
- H 2,5 mm
- H 3 mm
- H 4 mm
- H 5 mm
- H 6 mm
- H 8 mm
- H 10 mm



Nr. Spezifikation
18500



5

FESTA

SET INBUSSCHLÜSSEL
VERLÄNGERT

- H 1,5 mm
- H 2 mm
- H 2,5 mm
- H 3 mm
- H 4 mm
- H 5 mm
- H 6 mm
- H 8 mm
- H 10 mm



Nr. Spezifikation
18490



5

FESTA

SET INBUSSCHLÜSSEL
MIT KOPFSTÜCK

- H 1,5 mm
- H 2 mm
- H 2,5 mm
- H 3 mm
- H 4 mm
- H 5 mm
- H 6 mm
- H 8 mm
- H 10 mm



Nr. Spezifikation
18498



5

FESTA

SET INBUSSCHLÜSSEL
MIT KOPFSTÜCK

- 1/16"
- 5/64"
- 3/32"
- 1/8"
- 5/32"
- 3/16"
- 1/4"
- 5/16"
- 3/8"



Nr. Spezifikation
18493



6

FESTA

TORX-SCHLÜSSEL-SET

- T 10 mm
- T 15 mm
- T 20 mm
- T 25 mm
- T 27 mm
- T 30 mm
- T 40 mm
- T 45 mm
- T 50 mm



Nr. Spezifikation
18497



5

FESTA

SET INBUSSCHLÜSSEL MIT
KOPFSTÜCK - VERLÄNGERT

- H 1,5 mm
- H 2 mm
- H 2,5 mm
- H 3 mm
- H 4 mm
- H 5 mm
- H 6 mm
- H 8 mm
- H 10 mm



Nr. Spezifikation
18492



10

FESTA

TORX-SCHLÜSSEL-SET
VERLÄNGERT

- T 10 mm
- T 15 mm
- T 20 mm
- T 25 mm
- T 27 mm
- T 30 mm
- T 40 mm
- T 45 mm
- T 50 mm



Nr. Spezifikation
18491



5

FESTA

SET
INBUSSCHLÜSSEL



Nr. Spezifikation
18508 1,5 · 2 · 2,5 · 3 · 4 · 5 · 6 mm



1

SET
INBUSSCHLÜSSEL



Nr. Spezifikation
18499 2 · 2,5 · 3 · 4 · 5 · 6 · 8 · 10 mm



1

FESTA

DOPPELSEITIGER MAULSCHLÜSSEL

CrV DIN 3110



Nr.	Spezifikation	
17550	6 x 7 mm	10
17551	8 x 9 mm	10
17552	8 x 10 mm	10
17553	10 x 11 mm	10
17590	10 x 13 mm	10
17554	12 x 13 mm	10
17555	14 x 15 mm	10
17556	13 x 16 mm	10
17557	13 x 17 mm	10
17591	14 x 17 mm	10
17558	16 x 17 mm	10
17559	17 x 19 mm	10
17560	18 x 19 mm	10

Nr.	Spezifikation	
17592	19 x 22 mm	10
17593	19 x 24 mm	10
17561	20 x 22 mm	10
17569	21 x 23 mm	10
17548	22 x 24 mm	10
17562	24 x 27 mm	10
17549	24 x 30 mm	10
17563	30 x 32 mm	10
17564	30 x 34 mm	10
17565	32 x 36 mm	10
17566	36 x 41 mm	10
17567	46 x 50 mm	10
17568	50 x 55 mm	3

FESTA

SCHLÜSSEL FLACHÖSE

CrV DIN 3113



Nr.	Spezifikation	
17487	6 mm	10
17570	7 mm	10
17571	8 mm	10
17572	9 mm	10
17573	10 mm	10
17574	11 mm	10
17575	12 mm	10
17576	13 mm	10
17577	14 mm	10
17578	15 mm	10
17579	16 mm	10
17580	17 mm	10
17581	18 mm	10
17582	19 mm	10
17488	20 mm	10

Nr.	Spezifikation	
17489	21 mm	10
17583	22 mm	10
17490	23 mm	10
17584	24 mm	10
17491	25 mm	10
17492	26 mm	10
17585	27 mm	10
17493	28 mm	10
17494	29 mm	10
17586	30 mm	10
17587	32 mm	10
17495	33 mm	10
17496	34 mm	10
17589	36 mm	10

FESTA

SCHLÜSSEL RATSCHENSCHLÜSSEL ARTIKULIERT

CrV 72T



Nr.	Spezifikation	
17628	8 mm	10
17622	10 mm	10
17623	13 mm	10
17624	14 mm	10
17629	15 mm	10
17630	16 mm	5

Nr.	Spezifikation	
17625	17 mm	10
17631	18 mm	10
17626	19 mm	10
17632	21 mm	5
17633	22 mm	5

FESTA

SCHLÜSSEL RATSCHENSCHLÜSSEL

CrV 72T



Nr.	Spezifikation	
17660	6 mm	10
17676	7 mm	10
17661	8 mm	10
17662	9 mm	10
17663	10 mm	10
17664	11 mm	10
17665	12 mm	10
17666	13 mm	10
17667	14 mm	10
17668	15 mm	10

Nr.	Spezifikation	
17669	16 mm	10
17670	17 mm	10
17671	18 mm	10
17672	19 mm	10
17674	21 mm	5
17675	22 mm	5
17677	24 mm	5
17678	27 mm	5
17679	30 mm	5
17683	32 mm	5

FESTA

SCHLÜSSEL DOPPELSEITIGER MAULSCHLÜSSEL

DIN 895



Nr.	Spezifikation	
17460	6 x 7 mm	10
17461	8 x 9 mm	10
17462	8 x 10 mm	10
17463	10 x 11 mm	10
17481	10 x 13 mm	10
17464	12 x 13 mm	10
17465	14 x 15 mm	10
17467	13 x 17 mm	10
17482	14 x 17 mm	10
17468	16 x 17 mm	10

Nr.	Spezifikation	
17469	17 x 19 mm	10
17470	18 x 19 mm	10
17483	19 x 22 mm	10
17484	19 x 24 mm	10
17471	20 x 22 mm	10
17472	24 x 27 mm	10
17486	21 x 23 mm	10
17480	28 x 30 mm	10
17473	30 x 32 mm	10
17485	36 x 41 mm	10

FESTA

SCHLÜSSEL RINGSCHLÜSSEL GEBOGEN

CrV DIN 838



Nr.	Spezifikation	
17605	6 x 7 mm	10
17606	8 x 9 mm	10
17607	8 x 10 mm	10
17608	10 x 11 mm	10
17609	12 x 13 mm	10
17611	13 x 16 mm	10
17612	13 x 17 mm	10

Nr.	Spezifikation	
17610	14 x 15 mm	10
17613	16 x 17 mm	10
17614	18 x 19 mm	10
17615	20 x 22 mm	10
17616	24 x 27 mm	10
17617	30 x 32 mm	10

FESTA

DOPPELSEITIGER MAULSCHLÜSSEL

CrV DIN 3110



Nr.	Spezifikation	
17761	14 x 15 mm	10
17769	20 x 22 mm	10

FESTA

SCHLÜSSEL FLACHÖSE

CrV DIN 3113



Nr.	Spezifikation	
17788	14 mm	10
17795	21 mm	10
17806	33 mm	10

FESTA

**SCHLÜSSEL
RATSCHENSCHLÜSSEL**

8-9-10-11-12-13-14-15-16-17-18-19 mm



Nr.	Spezifikation	
17619		1



NEW

FESTA

SCHLÜSSEL, UNIVERSALSCHLÜSSEL

Cr-Mo



Nr.	Spezifikation	
17685	12-13-14-15-16-17-18-19 mm	1

12-13-14-15 mm



16-17-18-19 mm

FESTA

SCHLÜSSEL VERSTELLBAR

CrV



Nr.	Umfang	Dauer	
17197	0 - 29 mm	200 mm	1
17198	0 - 33 mm	250 mm	1
17199	0 - 38 mm	300 mm	1



SCHLÜSSEL VERSTELLBAR

Nr.	Umfang	Dauer	
17200	0 - 24 mm	200 mm	6
17201	0 - 30 mm	250 mm	6
17202	0 - 34 mm	300 mm	6



FESTA



FESTA

**SCHLÜSSEL MAULSCHLÜSSEL
DOPPELSEITIG - SET**

CrV

DIN 3110



Nr.	Spezifikation	
17506	6 St. · 6 x 7, 8 x 9, 10 x 11, 12 x 13, 14 x 15, 16 x 17	1
17508	8 St. · 6 x 7, 8 x 9, 10 x 11, 12 x 13, 14 x 15, 16 x 17, 18 x 19, 20 x 22	1



FESTA

**SCHLÜSSEL
FLACHÖSE - SET**

CrV

DIN 3113



Nr.	Spezifikation	
17526	6 St. · 10 x 10, 11 x 11, 13 x 13, 14 x 14, 16 x 16, 17 x 17	1
17528	8 St. · 8 x 8, 10 x 10, 11 x 11, 13 x 13, 14 x 14, 16 x 16, 17 x 17, 19 x 19	1



FESTA

**SCHLÜSSEL RINGSCHLÜSSEL
GEBOGEN - SET**

8x

CrV

DIN 838



Nr.	Spezifikation	
17539	6 x 7, 8 x 9, 10 x 11, 12 x 13, 14 x 15, 16 x 17, 18 x 19, 20 x 22	1



FESTA

SCHLÜSSEL FLACHÖSE - SET

CrV

DIN 3113



Nr.	Spezifikation	
17532	12 St. · 8 x 8, 9 x 9, 10 x 10, 11 x 11, 13 x 13, 14 x 14, 16 x 16, 17 x 17, 18 x 18, 19 x 19, 21 x 21, 22 x 22	10
17533	18 St. · 6 x 6, 7 x 7, 8 x 8, 9 x 9, 10 x 10, 11 x 11, 12 x 12, 13 x 13, 14 x 14, 15 x 15, 16 x 16, 17 x 17, 18 x 18, 19 x 19, 20 x 20, 21 x 21, 22 x 22, 24 x 24	1
17534	25 St. · 6 x 6, 7 x 7, 8 x 8, 9 x 9, 10 x 10, 11 x 11, 12 x 12, 13 x 13, 14 x 14, 15 x 15, 16 x 16, 17 x 17, 18 x 18, 19 x 19, 20 x 20, 21 x 21, 22 x 22, 23 x 23, 24 x 24, 25 x 25, 26 x 26, 27 x 27, 28 x 28, 30 x 30, 32 x 32	4

FESTA

SCHLÜSSEL MAULSCHLÜSSEL DOPPELSEITIG - SET

CrV DIN 3110

12x



Nr.	Spezifikation	
17512	6 x 7, 8 x 9, 10 x 11, 12 x 13, 14 x 15, 16 x 17, 18 x 19, 20 x 22, 21 x 23, 24 x 27, 25 x 28, 30 x 32	1

FESTA

SCHLÜSSEL MAULSCHLÜSSEL - SET DIN 895

DIN 895



Nr.	Spezifikation	
17475	8 St. · 6 x 7, 8 x 9, 10 x 11, 12 x 13, 14 x 15, 16 x 17, 18 x 19, 20 x 22	5
17476	12 St. · 6 x 7, 8 x 9, 10 x 11, 12 x 13, 14 x 15, 16 x 17, 18 x 19, 20 x 22, 21 x 23, 24 x 27, 28 x 30, 30 x 32	3



SCHLÜSSEL FÜR WINKELSCHLEIFER



Nr.	Spezifikation	
20967	200 mm	15

FESTA

SCHLÜSSEL RATSCHENSCHLÜSSEL - SET

CrV

72T

7x



Nr.	Spezifikation	
17620	8, 10, 12, 13, 14, 17, 19	5

FESTA

SCHLÜSSEL RATSCHENSCHLÜSSEL, ARTIKULIERT - SET

CrV

72T

7x



Nr.	Spezifikation	
17621	10, 12, 13, 14, 15, 17, 19	5

FESTA

SCHLÜSSEL ROHRSCHLÜSSEL SET

CrV

7x



Nr.	Spezifikation	
17501	6 x 7, 8 x 9, 10 x 11, 12 x 13, 14 x 15, 16 x 17, 18 x 19	20
17640	Hebel für Rohrschlüssel · 135 mm	50

FESTA

ROHRSCHLÜSSEL

CrV



Nr.	Spezifikation		Nr.	Spezifikation	
17650	6 x 7 mm	10	17655	16 x 17 mm	10
17651	8 x 9 mm	10	17645	16 x 18 mm	10
17642	8 x 10 mm	10	17653	16 x 21 mm	10
17652	10 x 11 mm	10	17656	18 x 19 mm	10
17643	12 x 13 mm	10	17657	19 x 22 mm	10
17654	14 x 15 mm	10	17659	22 x 24 mm	10
17644	14 x 17 mm	10	17658	24 x 27 mm	10



SCHLÜSSEL FÜR WINKELSCHLEIFER



Nr.	Spezifikation	
20968	200 mm	1

FESTA

GERÜST-BAURATSCHEN



Nr.	Spezifikation	
17452	19 x 22 mm	2



FESTA

GERÜST-BAURATSCHEN

Nr.	Spezifikation	
17451	18 mm	10
17450	19 mm	10



FESTA

SCHLÜSSEL DREHMOMENTSCHLÜSSEL

Nr.	Spezifikation	
17203	1/4" 5 - 25 Nm	1
17204	1/2" 19 - 110 Nm	1
17205	1/2" 42 - 210 Nm	1
17206	3/4" 140 - 700 Nm	1



FESTA

made by **HENITON**

RADKÖPFE

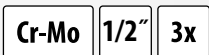

Č.p.	specifikace	
17338	21 mm	5



RADSCHLÜSSEL



Nr.	Spezifikation	
17600	17, 19, 22 mm, 13/16"	16

RADSCHLÜSSEL



Nr.	Spezifikation	
17601	17, 19, 21 mm	20

SCHLÜSSEL TELESKOP-RADMUTTERNSCHLÜSSEL



Nr.	Spezifikation	
17603	17 x 19 mm, 21 x 23 mm	20

SCHLÜSSEL STECKSCHLÜSSEL ARTIKULIERT



Nr.	Spezifikation	
17261	16 mm	1
17262	21 mm	1

FESTA

SCHLÜSSEL
HAKEN-SCHLÜSSEL

CrV



Nr.	Spezifikation		
17680	19 - 51 mm	165 mm	5
17681	32 - 76 mm	216 mm	5
17682	51 - 121 mm	267 mm	5

LAGERABZIEHER
- DOPPELARMIG



Nr.	max. Durchmesser	Tiefe	
23734	Ø 100 mm	50-95 mm	1
23735	Ø 150 mm	100-150 mm	1
23736	Ø 200 mm	110-190 mm	1

LAGERABZIEHER
- DREIARMIG



Nr.	max. Durchmesser	Tiefe	
23730	Ø 100 mm	50-95 mm	2
23731	Ø 150 mm	100-150 mm	2
23732	Ø 200 mm	110-190 mm	2

FESTA

SCHRAUBENSCHLÜSSEL
FÜR HEIZKÖRPERMONTAGE

CrV 1/2"

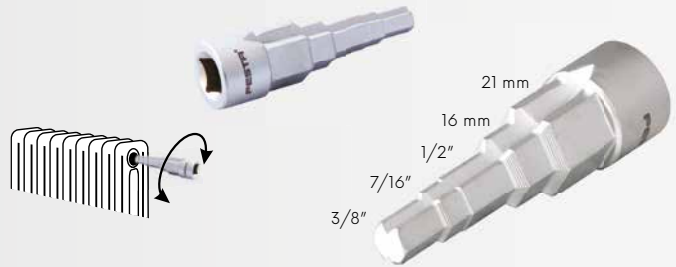

Nr.	Spezifikation	
17455	für Ratsche 1/2"	10



ENTLÜFTUNGSSCHLÜSSEL

HEIZKÖRPERENTLÜFTER
MIT BEHÄLTER

2x



Nr.	Spezifikation	
17454	5 x 5 mm	1

Nr.	Spezifikation	
17459	50 ml	1



FESTA

UNIVERSALSCHLÜSSEL
FÜR VERTEILERKASTEN

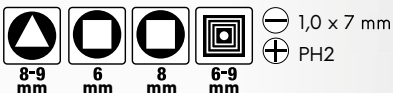

Nr.	Spezifikation	
17458		1



FESTA

UNIVERSALSCHLÜSSEL
FÜR VERTEILERKASTEN

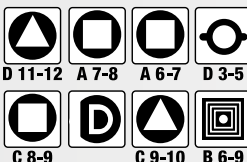

Nr.	Spezifikation	
17456		50





ERGONOMIC handle

STANDARD +30% FESTA



KOMBIZANGE

DIN 5746	TUV GS	Nr.	Spezifikation	
		17101	160 mm	6
		17102	180 mm	6
CrV	HRC 58-62	17103	200 mm	6



SEITENSPLTZANGE

DIN 5749	TUV GS	CrV	HRC 58-62	ERGO HANDLE	Nr.	Spezifikation	
					17148	180 mm	6



SEITENSPLTZANGE

DIN 5749	TUV GS	CrV	HRC 58-62	ERGO HANDLE	Nr.	Spezifikation	
					17104	160 mm	6
					17105	180 mm	6



FUNKZANGE

DIN 5745	TUV GS	CrV	HRC 58-62	ERGO HANDLE	Nr.	Spezifikation	
					17140	160 mm	6
					17142	200 mm	6



FUNKZANGE GEBOGEN

DIN 5749	TUV GS	CrV	HRC 58-62	ERGO HANDLE	Nr.	Spezifikation	
					17145	160 mm	6
					17146	200 mm	6



FESTA





FESTA

KOMBIZANGE

DIN 5746				
Nr.	Spezifikation			
17001	160 mm	6		
17002	180 mm	6		
17003	200 mm	6		



FESTA

SEITENSPALTZANGE

DIN 5749				
Nr.	Spezifikation			
17004	160 mm	6		
17005	180 mm	6		



FESTA

SEITENSPALTZANGE

DIN 5749				
Nr.	Spezifikation			
17108	180 mm	6		



FESTA

FRONTSPALTZANGE

DIN 5748				
Nr.	Spezifikation			
17110	160 mm	6		



FESTA

FUNKZANGE

DIN 5745				
Nr.	Spezifikation			
17006	160 mm	6		
17011	200 mm	6		



FESTA

FUNKZANGE GEBOGEN

DIN 5745				
Nr.	Spezifikation			
17007	160 mm	6		
17008	200 mm	6		



FESTA

FLACHZANGE

DIN 5746				
Nr.	Spezifikation			
17009	160 mm	6		



FESTA

RINGZANGE

DIN 5745			
Nr.	Spezifikation		
17010	160 mm	6	



FESTA

ABISOLIERZANGE

DIN 5744			
Nr.	Spezifikation		
17024	160 mm	6	



KOMBIZANGE

DIN 5746		
Nr.	Spezifikation	
17094	160 mm	6
17095	180 mm	6
17096	200 mm	6



SEITENSPALTZANGE

DIN 5749		
Nr.	Spezifikation	
17097	160 mm	6
17098	180 mm	6



FUNKZANGE

DIN 5745		
Nr.	Spezifikation	
17099	160 mm	6
17100	200 mm	6



VDE KOMBIZANGE

1000 V IEC/EN60900:2004 **DIN 5746** **CrV** **HRC 58-62**

Nr.	Spezifikation	
17125	160 mm	6
17126	180 mm	6
17127	200 mm	6



VDE-SEITENZANGE

1000 V IEC/EN60900:2004

DIN 5749 **CrV** **HRC 58-62**

Nr.	Spezifikation	
17128	160 mm	6



VDE-KABELZANGE/BEISSZANGE

1000 V IEC/EN60900:2004

CrV **HRC 58-62**

Nr.	Spezifikation	
17130	160 mm	6



VDE-FUNKZANGE

1000 V IEC/EN60900:2004

DIN 5745 **CrV** **HRC 58-62**

Nr.	Spezifikation	
17133	160 mm	6



VDE FUNKZANGE GEBOGEN

1000 V IEC/EN60900:2004

DIN 5745 **CrV** **HRC 58-62**

Nr.	Spezifikation	
17135	160 mm	6



VDE-RINGZANGE

1000 V IEC/EN60900:2004

DIN 5745 **CrV** **HRC 58-62**

Nr.	Spezifikation	
17137	160 mm	6



VDE - ABISOLIERZANGE

1000 V IEC/EN60900:2004

CrV **DIN 5744**

Nr.	Spezifikation	
17138	160 mm	6



MINI SEITENZANGE

max Ø 0,2 - 2,1 mm

CrV

Nr.	Spezifikation	
17047	140 mm	10



MINI SEITENZANGE

0,75; 1,0; 1,5; 2,5; 4,0; 6,0mm²

CrV

Nr.	Spezifikation	
17087	145 mm	1



ABISOLIERZANGE

0,5 - 6 mm²
190 mm

Nr.	Spezifikation	
17178		1



ABISOLIERZANGE

Nr.	Spezifikation	
17180	Ø 0,75 - 2,5 mm	12



ABISOLIERZANGE

Nr.	Spezifikation	
17181	Ø 0,60 - 2,6 mm	10

NEW



FESTA
KABELABISOLIERER

· Ø 0,2-4 mm

Nr.	Spezifikation	
16205	125 mm	1

FESTA
KABELABISOLIERER

AWG	mm ²
10	6,0
12	4,0
14	2,5
16	1,5
18	1,0
20	0,5

· Koaxialkabel RG6/59
· Niederspannungskabel Ø 8 - 13 mm

Nr.	Spezifikation	
16202	125 mm	10



FESTA
INDUSTRY
CRIMPZANGE

6x

Nr.	Spezifikation	
18445		1

NEW

- AWG 22-18/16-14/12-10
· DIN 0,5-1,0/1,5-2,5/4-6mm²
- AWG 20-16/16-14/12-10/8
· DIN 0,5-1,0/1,5-2,5/4-6/10mm²
- AWG 20-18/16-14/12-10
· DIN 0,5-1,0/1,5-2,5/4-6mm²
- AWG 20/18/17/16/14/12
· DIN 0,5/0,75/1,0/1,5/2,5/4,0mm²
- AWG 10/8/6
· DIN 6/10/16mm²



FESTA
INDUSTRY
CRIMPZANGE

Nr. 16206

Spezifikation	
	1

- AWG 10-22
· 0,5-0,6mm²
- AWG 10-22
· 0,5-0,6mm²
- AWG 10-22
· 0,5-0,6mm²
- Abisolieren
· AWG 10-24
· 0,2-0,6mm²



FESTA
INDUSTRY
CRIMPZANGE

Nr. 16208

Spezifikation		· Abschneiden Gewindestiften	· M2,6; M3; M3,5; M4; M5
	1	· 1,5; 2,5; 6,0mm ²	
		· 1,5; 2,5; 6,0mm ²	
		· Abisolieren	· 0,75; 1,0; 1,5; 2,5; 4,0; 6,0mm ²



FESTA

MULTIFUNKTION-SZANGE

- 9 Funktionen
- Gehäuse

CrV

Nr.	Spezifikation	
16232		12



FESTA

MINI-ZANGE SET

4x

Nr.	Spezifikation	
17040		6



FESTA

MINI KOMBIZANGE

Nr.	Spezifikation	
17041	110 mm	12



FESTA

MINI SEITENZANGE

Nr.	Spezifikation	
17042	110 mm	12



FESTA

MINI BEISSZANGE

Nr.	Spezifikation	
17043	100 mm	12



FESTA

MINI FUNKZANGE

Nr.	Spezifikation	
17044	120 mm	12



FESTA

MINI RINGZANGE

Nr.	Spezifikation	
17045	120 mm	12



ZANGEN FÜR SEEGERRINGE

Nr.	Spezifikation	
17025	Set	10



FESTA

ZANGEN FÜR SEEGERRINGE

Nr.	Spezifikation	
17190	180 mm innen	6
17191	180 mm außen	6



FESTA

ZANGEN FÜR SEEGERRINGE

Nr.	Spezifikation	
17192	180 mm innen	15
17193	180 mm außen	15



FESTA

MULTIFUNKTION-SZANGE

für Zauninstallation

CrV



Nr.	Spezifikation
17109	270 mm



SCHWEISSER GRIP-ZANGE

Č.p.	Spezifikace		
17150	220 mm	1	



SCHNELLER GRIFF-SCHLÜSSEL

Č.p.	Spezifikace		
17151	225 mm	1	



SCHNELLSPANNZANGE

Č.p.	specifikace		
17034	220 mm	5	



FESTA

SCHNELLSPANNZANGE

Č.p.	specifikace		
17036	270 mm	5	



SCHNELLSPANNZANGE

Č.p.	specifikace		
17035	220 mm	10	



FESTA

SCHNELLSPANNZANGE

Č.p.	specifikace		
17023	220 mm	6	

FESTA

ROHRSCHLÜSSEL 45°, S

CrV



Nr.	Spezifikation	
17067	1" 330 mm	1
17068	1,5" 420 mm	1
17069	2" 540 mm	1



FESTA

ROHRSCHLÜSSEL MIT FESTSTELLSCHRAUBE

CrV

Nr.	Spezifikation	
17063	230 mm	6
17064	300 mm	6

FESTA

ROHRSCHLÜSSEL 90°

CrV



Nr.	Spezifikation	
17075	1" 330 mm	1
17076	1,5" 420 mm	1
17077	2" 540 mm	1



ROHRSCHLÜSSEL MIT LEITMUTTER

Nr.	Spezifikation	
17065	260 mm	36
17066	300 mm	36

FESTA

ROHRSCHLÜSSEL 90°

CrV



Nr.	Spezifikation	
17070	2,5" 355 mm	12
17071	3" 455 mm	8
17072	3,5" 610 mm	10



FESTA

WASSERPUMPENZANGE



CrV

Nr.	Spezifikation	Backenweite	
16500	180 mm	0 - 40 mm	1
16501	250 mm	0 - 52 mm	1
16502	300 mm	0 - 68 mm	1

FESTA

SIKO-ZANGE MIT DRUCKKNOPF



CrV

Nr.	Spezifikation	Backenweite	
17059	180 mm	0 - 30 mm	6
17061	250 mm	0 - 30 mm	6
17062	300 mm	0 - 40 mm	6
17080	400 mm	0 - 84 mm	4

FESTA

SIKO-ZANGE MIT DRUCKKNOPF



CrV

Nr.	Spezifikation	Backenweite	
17084	250 mm	0 - 30 mm	6

FESTA

SIKO-ZANGE



CrV

· velký Backenweite

Nr.	Spezifikation	Backenweite	
17086	250 mm	0 - 50 mm	6

FESTA

SIKO-ZANGE



CrV

Nr.	Spezifikation	Backenweite	
17081	180 mm	0 - 30 mm	6
17014	250 mm	0 - 30 mm	6
17082	300 mm	0 - 50 mm	6

FESTA

SIKO-ZANGE AUTOMATISCH EINSTELLBAR



CrV

Nr.	Spezifikation	Backenweite	
17079	250 mm	0 - 50 mm	6

FESTA

SIKO-ZANGE



CrV

Nr.	Spezifikation	Backenweite	
17012	250 mm	0 - 40 mm	6
17060	300 mm	0 - 50 mm	10

FESTA

SIKO-ZANGE



CrV

Nr.	Spezifikation	Backenweite	
17013	250 mm	0 - 30 mm	6
17033	300 mm	0 - 50 mm	6

KUNSTSTOFFBACKEN FÜR SIKO-ZANGE

· geeignet für 17061, 17079, 17086



Nr.	Spezifikation	
17085	1 Paar	1

FESTA

SEILZANGE



CrV

· Stahldrähte
· ACSR-Kabel
· Luftfahrtkabel

Č.p.	specifikace	
17029	200 mm	6

FESTA

SEILZANGE



CrV

· Stahldrähte
· ACSR-Kabel
· Luftfahrtkabel

Č.p.	specifikace	
17039	24' 610 mm	8

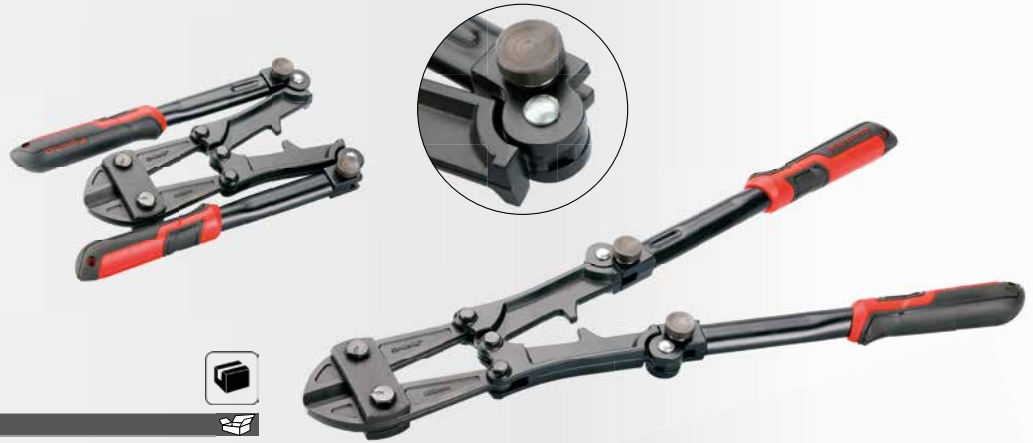

FESTA

**BOLZENSCHNEIDER,
KLAPPBAR**

Cr-Mo



Nr.	Spezifikation		
17049	18' 450 mm	max. 6 mm < 40 HRC	1

FESTA

PROFI-HEBELZANGE

Cr-Mo

HRC 58-62



Nr.	Spezifikation	max. Ø drátu	
17051	14' 350 mm	max. 5 mm < 45 HRC	1
17052	18' 450 mm	max. 6 mm < 45 HRC	1
17053	24' 610 mm	max. 8 mm < 45 HRC	1
17054	30' 760 mm	max. 10 mm < 45 HRC	1
17048	36' 900 mm	max. 12 mm < 45 HRC	1



FESTA

PROFI-HEBELZANGE

· Klemmbacken für Kabel und Seile

Cr-Mo

HRC 58-62



Nr.	Spezifikation	max. Ø drátu	max. Ø lanka	max. Ø kabelu	
17055	14' 360 mm	max. 5 mm < 45 HRC	max. 3,5 mm	max. 8 mm	1
17056	18' 460 mm	max. 6 mm < 45 HRC	max. 5 mm	max. 10 mm	1
17057	24' 610 mm	max. 8 mm < 45 HRC	max. 7 mm	max. 12 mm	1
17058	30' 760 mm	max. 10 mm < 45 HRC	max. 9 mm	max. 14 mm	1
17046	35' 900 mm	max. 12 mm < 45 HRC	max. 10 mm	max. 16 mm	1



FESTA

HEBELZANGE

Cr-Mo

HRC 57-62

**max. Ø
4 mm**



CrV



Nr.	Spezifikation		
17038	8' 210 mm	max. 4 mm < 30 HRC	10

Nr.	Spezifikation		
17078	200 mm		12

FESTA

HEBELZANGE

· weicher Draht: Ø 6 mm
· mittelharter Draht: Ø 5 mm
· Harter Draht: Ø 4 mm



HEBELZANGE



Nr.	Spezifikation	max. Ø drátu	
17028	14' 350 mm	max. 5 mm < 30 HRC	30
17020	18' 450 mm	max. 6 mm < 30 HRC	6
17021	24' 610 mm	max. 8 mm < 30 HRC	10
17022	30' 760 mm	max. 10 mm < 30 HRC	5

NEW



FESTA

FRONTSPALTZANGE

CrV HRC 58-62

Nr.	Spezifikation	
17172	200 mm	1



FESTA

FRONTSPALTZANGE

CrV

Nr.	Spezifikation	
17300	160 mm	1
17301	180 mm	10
17302	200 mm	6
17303	250 mm	1



FESTA

RABITZANGE

CrV

Nr.	Spezifikation	
17305	220 mm	5
17306	250 mm	1
17304	275 mm	6



FRONTSPALTZANGE

Nr.	Spezifikation	
17015	160 mm	6
17016	180 mm	6
17017	200 mm	6



RABITZANGE

Nr.	Spezifikation	
17019	220 mm	6
17083	275 mm	6



FESTA

GERADE KLEMPNERZANGE

Nr.	Spezifikation	
17089	150 x 215 mm	2

NEW



FESTA

GERADE KLEMPNERZANGE

Nr.	Spezifikation	
17341	24 x 180 mm	1

NEW



FESTA

GEBOGENE KLEMPNERZANGE 45°

Nr.	Spezifikation	
17342	24 x 180 mm	1



FESTA

GERADE KLEMPNERZANGE

Nr.	Spezifikation	
17093	95 x 270 mm	6



FESTA

GEBOGENE KLEMPNERZANGE 45°

Nr.	Spezifikation	
17091	50 x 280 mm	10



FESTA

GEBOGENE KLEMPNERZANGE 90°

Nr.	Spezifikation	
17092	50 x 260 mm	10



FESTA

GERADE KLEMPNERZANGE

Nr.	Spezifikation	
17090	50 x 280 mm	10



FESTA
BLECHSCHERE

CrV	Nr.	Spezifikation	
	17170	50 250 mm	6



BLECHSCHERE

CrV	Nr.	Spezifikation	
	17167	70 300 mm	5



BLECHSCHERE

CrV	Nr.	Spezifikation	
	17165	60 250 mm	5



BLECHSCHERE

CrV	Nr.	Spezifikation	
	17169	35 250 mm	5

FESTA
BLECHSCHERE EXTRA LANG



Cr-Mo HRC 58-62



Nr.	Spezifikation		
17113	gerade	80 300 mm	6

FESTA
BLECHSCHERE

Cr-Mo HRC 58-62



Nr.	Spezifikation		
17111	gerade	40 250 mm	6
17116	rechtsseitig	40 250 mm	6
17121	linSt.seitig	40 250 mm	6

FESTA
BLECHSCHERE

Cr-Mo HRC 58-62



Nr.	Spezifikation		
17112	gerade	40 260 mm	6
17117	rechtsseitig	40 260 mm	6
17122	linSt.seitig	40 260 mm	6



KNABBER-BOHRAUFSATZ AUS METALL



Nr.	Spezifikation	
20364		1



BLECHSCHERE



Nr.	Spezifikation	
17186	265 mm	6



HEBELSCHERE

	17175	17177
max. Blechstärke	max. 4mm	5mm
max. Ø Loch	max. Ø10mm	Ø12mm
max. Schnittgröße	max. 8x8mm	10x10mm

Nr.	Spezifikation	
17175	150 mm	1
17177	250 mm	1



BLECHSCHNEIDE-VORRICHTUNG

- Max. Blechstärke
- 1,8 mm - Stahl
 - 1,2 mm - rostfreier Stahl
 - 2 mm - Kunststoff, Aluminium, Kupfer

Nr.	Spezifikation	
20363		5





TECHNISCHE SCHERE

INOX



Č.p.	specifikace	
16420	60 200 mm	12



SCHERE

INOX



Č.p.	specifikace	
17159	65 220 mm	12



TECHNISCHE SCHERE

INOX



Č.p.	specifikace	
17158	50 150 mm	10



SCHERE

INOX



Č.p.	specifikace	
17160	70 210 mm	12



SCHERE

INOX

Č.p.	specifikace	
16405	14 cm	24
16406	17 cm	24
16407	19 cm	24
16408	21,5 cm	12



SCHERE SET

3x INOX

Č.p.	specifikace	
16401	3 ks	48



FESTA

STANZZANGE



Nr.	Spezifikation	
17185	Ø 2; 2,5; 3; 3,5; 4; 4,5 mm	12



FESTA

SCHERE FÜR PVC-LEISTEN UND ROHRE

Verwendung für: Leisten, Rohre, Profile



Nr.	Spezifikation	
17050	60 250 mm ø 17 mm, ø 20 mm, ø 27 mm	8



VERBINDUNGSZANGE ZUM PERFORIEREN VON PROFILEN



Nr.	Spezifikation	
17187	350 mm	6



VERBINDUNGSZANGE ZUM PERFORIEREN VON PROFILEN



Nr.	Spezifikation	
17188	250 mm	12



DÜBELZANGE



Nr.	Spezifikation	
17189	255 mm	12





FESTA

FESTA
NIETZANGE

Cr-Mo

- Ø 2,4 mm
- Ø 3,2 mm
- Ø 4,0 mm
- Ø 4,8 mm



Nr. Spezifikation
24007 200 mm



1



FESTA
NIETZANGE

Cr-Mo

- Ø 2,4 mm
- Ø 3,2 mm
- Ø 4,0 mm
- Ø 4,8 mm



Nr. Spezifikation
24010 250 mm



12



FESTA
NIETZANGE

Cr-Mo

- Ø 2,4 mm
- Ø 3,2 mm
- Ø 4,0 mm
- Ø 4,8 mm
- Ø 6,4 mm



Nr. Spezifikation
24017 280 mm



1



FESTA
NIETZANGE

Cr-Mo

- Ø 2,4 mm
- Ø 3,2 mm
- Ø 4,0 mm
- Ø 4,8 mm
- Ø 6,4 mm



Nr. Spezifikation
24015 530 mm



1



FESTA
NIETZANGE

Cr-Mo

- Ø 2,4 mm
- Ø 3,2 mm
- Ø 4,0 mm
- Ø 4,8 mm



Nr. Spezifikation
24030 255 mm



24



FESTA
NIETZANGE
MIT DREHKOPF

Cr-Mo



Nr. Spezifikation
24020 290 mm



8





NIETZANGE, FEST



Cr-Mo

- Ø 2,4 x 6 mm
- Ø 3,2 x 6 mm
- Ø 4,0 x 6 mm
- Ø 4,8 x 6 mm

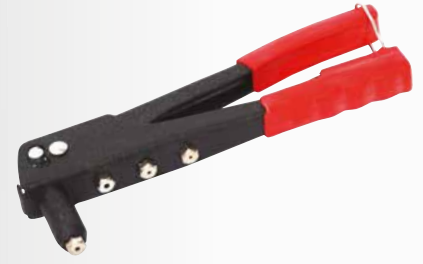

NIETZANGE



Nr.	Spezifikation	
24001	260 mm	6

Nr.	Spezifikation	
24005	260 mm	5

Nr.	Spezifikation	
24000	240 mm	24

FESTA

NIET-AUFSATZ

- Ø 2,4 mm
- Ø 3,2 mm
- Ø 4,0 mm
- Ø 4,8 mm



Cr-Mo



Nr.	Spezifikation	
24008		1

REISSNIETEN AUS ALUMINIUM

ALU

50x



Nr.	Spezifikation	
23970	3,2 x 6 mm	25
23971	3,2 x 8 mm	25
23972	3,2 x 10 mm	25
23973	3,2 x 12 mm	25
23974	3,2 x 14 mm	25
23975	4,0 x 6 mm	25
23976	4,0 x 8 mm	25
23977	4,0 x 10 mm	25
23978	4,0 x 12 mm	25
23979	4,0 x 14 mm	25
23985	4,8 x 6 mm	25
23986	4,8 x 8 mm	25
23987	4,8 x 10 mm	25
23988	4,8 x 12 mm	25
23989	4,8 x 14 mm	25



FESTA

NIETZANGE FÜR NIETMUTTERN

Cr-Mo

- M3
- M4
- M5
- M6
- M8
- M10



Nr.	Spezifikation	
24036	330 mm	1

FESTA

KOPF FÜR NIETZANGE FÜR NIETMUTTERN

· geeignet für 24035, 24036

Cr-Mo



Nr.	Spezifikation	
24038	M3	1
24039	M4	1
24040	M5	1
24041	M6	1
24042	M8	1
24043	M10	1



FESTA

NIETZANGE FÜR NIETMUTTERN

Cr-Mo

- M3
- M4
- M5
- M6



Nr.	Spezifikation	
24035	200 mm	1

NIETMUTTERN

ALU

20x







Nr.	Spezifikation	
23950	M3 x 9 mm	20
23951	M4 x 11 mm	20
23952	M5 x 12 mm	50
23953	M6 x 14 mm	50
23954	M8 x 16,5 mm	25
23955	M10 x 18 mm	20



FESTA

5-IN-1-HEFTER





-  | 6 - 14 mm
23960 - 23964
23760 - 23764,
23906 - 23914
-  | 10 - 14 mm
23965
-  | 15 mm
23966
-  | 15 mm
23967



Nr.	Spezifikation	
23927		6

FESTA

4-IN-1-HEFTER



-  | 6 - 14 mm
23960 - 23964
-  | 12 mm
23965
-  | 14 mm
23966
-  | 14 mm
23967



Nr.	Spezifikation	
23924		12

FESTA

3-IN-1-HEFTER

-  | 6 - 14 mm
23960 - 23964
-  | 14 mm
23966
-  | 14 mm
23967





Nr.	Spezifikation	
23923		12



FESTA

HEFTER

-  53 | 4 - 14 mm
23904 - 23914,
23760 - 23765

Nr.	Spezifikation	
23925	4 - 14 mm mit Arretierung	20

HEFTER

-  53 | 4 - 14 mm
23760 - 23765,
23904 - 23914

Nr.	Spezifikation	
23800		20

HEFTER



-  | $\alpha=9-11\text{ mm}, b=5,5\text{ mm}, c=6,4\text{ mm}$

Nr.	Spezifikation	
23920		4

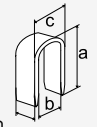

FESTA

HEFTHAMMER

-  | 6 - 10 mm
23960 - 23962

Nr.	Spezifikation	
23922		10



HEFTHAMMER

-  | 6 - 10 mm
23960 - 23962

Nr.	Spezifikation	
23928		6



FESTA

KLAMMERENTFERNER

Nr.	Spezifikation	
23945		25

FESTA

ZUSÄTZLICHE KLAMMERN



Nr.	Spezifikation	
23960	b=6 mm, 1000 St.	50
23961	b=8 mm, 1000 St.	50
23962	b=10 mm, 1000 St.	50
23963	b=12 mm, 1000 St.	50
23964	b=14 mm, 1000 St.	50

FESTA

KLAMMERN

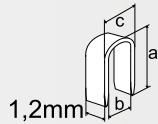

Nr.	Spezifikation	
23965	α=12 mm, b=6,5 mm, c=7,5 mm, 1000 TW	50

HEFTKLAMMER - TYP 53



Nr.	Spezifikation	
23904	b=4 mm 1000 St.	200
23906	b=6 mm 1000 St.	200
23908	b=8 mm 1000 St.	200
23910	b=10 mm 1000 St.	200
23912	b=12 mm 1000 St.	200
23914	b=14 mm 1000 St.	200

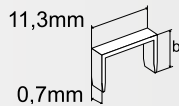

FESTA

NÄGEL



Nr.	Spezifikation	
23966	Nägel 14 mm 1000 TW	100

FESTA

NÄGEL



Nr.	Spezifikation	
23967	Nägel 14 mm 1000 TW	100

HEFTKLAMMER - TYP 53



Nr.	Spezifikation	
23760	b=4 mm 2000 St.	10
23761	b=6 mm 2000 St.	10
23762	b=8 mm 2000 St.	10
23763	b=10 mm 2000 St.	10
23764	b=12 mm 2000 St.	10

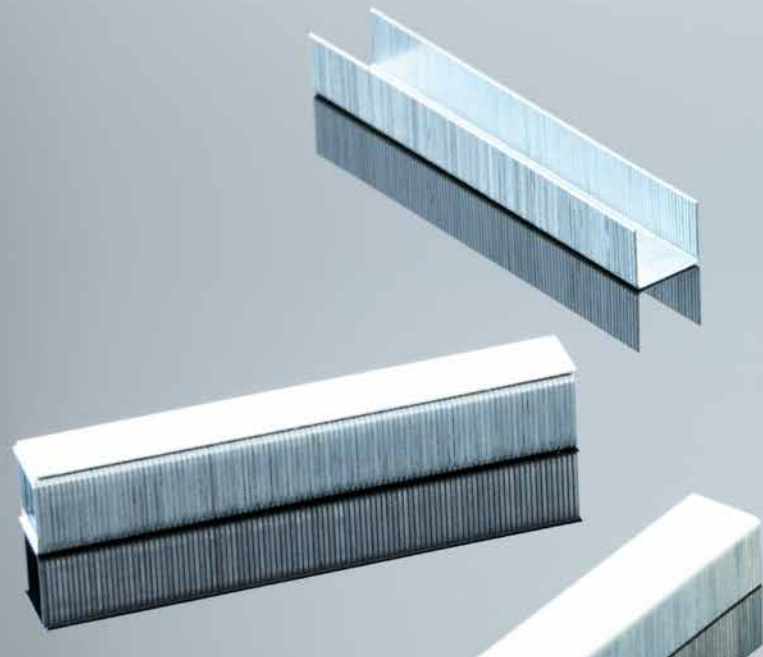
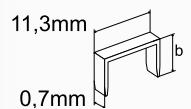

FESTA



FESTA

STAHLBÜRSTE



Nr.	Spezifikation	Reihen	
22080	270 mm	5 Reihen	12

FESTA

MESSINGBÜRSTE



Nr.	Spezifikation	Reihen	
22082	270 mm	5 Reihen	12

FESTA

BÜRSTEN SET



Nylon, Edelstahl, Messing

3x

Nr.	Spezifikation	
22086	180 mm	12

STAHLBÜRSTEN, VERMESSINGT SET



3x

Nr.	Reihen	
22081	3 Reihen	12



DRAHTBÜRSTE

Nr.	Spezifikation	draht	
22158	200 mm	Stahl	1
22159	200 mm	Messing	1



GEWELLTER PINSEL

Nr.	Spezifikation	draht	
22035	270 mm	Stahl	24
22036	270 mm	Edelstahl	24



STAHLBÜRSTE

Nr.	Spezifikation	Reihen	
22033	300 mm	4 Reihen	12
22034	300 mm	5 Reihen	12



BÜRSTE, VERMESSINGT
· vermessingt

Nr.	Reihen	
22078	3 Reihen	20



BÜRSTE, VERMESSINGT
· vermessingt

Nr.	Spezifikation	Reihen	
22079	300 mm	4 Reihen	6

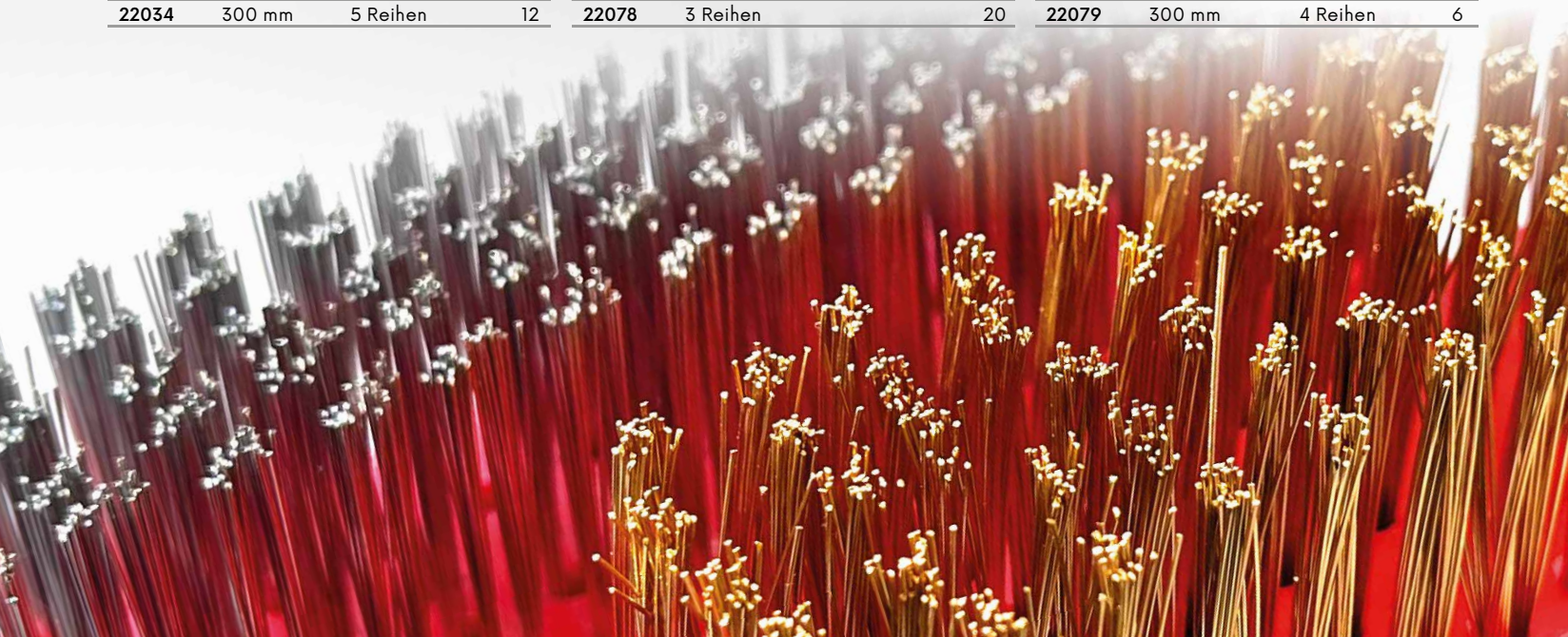

FESTA



FESTA FLACHFEILE



Nr.	Spezifikation	Grobheit	
22206	150 mm	2	10
22180	250 mm	2	10



FESTA HALBRUNDE FEILE



Nr.	Spezifikation	Grobheit	
22207	150 mm	2	10
22182	250 mm	2	10



FESTA VIERKANTFEILE



Nr.	Spezifikation	Grobheit	
22184	250 mm	2	10



FESTA DREIKANTFEILE



Nr.	Spezifikation	Grobheit	
22183	250 mm	2	10



FESTA DREIKANTFEILE FÜR SÄGEZÄHNE



Nr.	Spezifikation	Grobheit	
22178	150 mm	1	10

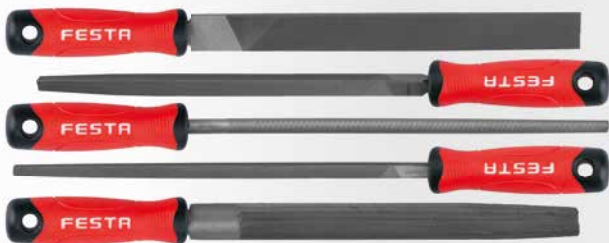

FESTA FEILE - SET



Nr.	Spezifikation	Grobheit	
22209	150 mm	2	10
22186	250 mm	2	5



FESTA RUNDE FEILE



Nr.	Spezifikation	Grobheit	
22181	250 mm	2	10

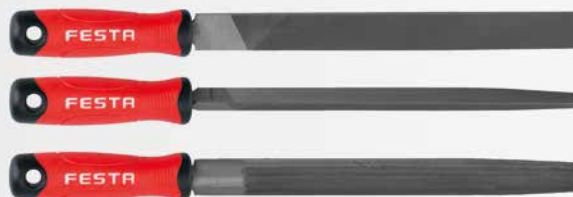

FESTA FEILE - SET



Nr.	Spezifikation	Grobheit	
22208	150 mm	2	10
22185	250 mm	2	5



FESTA

FEILE FÜR KETTENSÄGE



Nr.	Spezifikation		Nr.	Spezifikation	
22170	200 mm 3,5 mm	10	22173	200 mm 5 mm	10
22171	200 mm 4 mm	10	22174	200 mm 5,5 mm	10
22172	200 mm 4,5 mm	10			



Ø 4 mm

FESTA

KETTENSCHLEIFEN-SET



Nr.	Spezifikation	
22190	300 mm	5



FESTA

NADELFEILEN - SET



10x	Nr.	Spezifikation	20
	22188		



FESTA

DIAMANTFEILEN - SET



10x	Nr.	Spezifikation	25
	22189		



FESTA

FLACHRASPEL



Nr.	Spezifikation	
22202	150 mm	10
22197	300 mm	10



FESTA

RASPEL-SET



3x	Nr.	Spezifikation	5
	22196	250 mm	



FESTA

HALBRUNDRASPEL



Nr.	Spezifikation	
22203	150 mm	6
22199	300 mm	6



FESTA

RUNDRASPEL



Nr.	Spezifikation	
22204	150 mm	10
22205	250 mm	10
22198	300 mm	10



FESTA

METALLSÄGE



FESTA

METALLSÄGE

· verstärkter Rahmen



METALLSÄGE

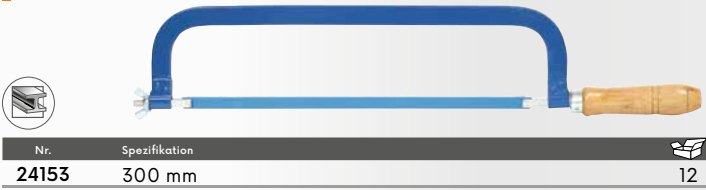

FESTA

METALLSÄGE



METALLSÄGE

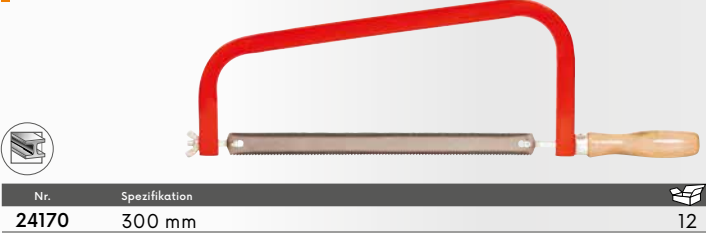

FESTA

METALLSÄGE



FESTA

METALLSÄGE

· Scheiben 24108



FESTA

METALLSÄGE

· Scheiben 24109

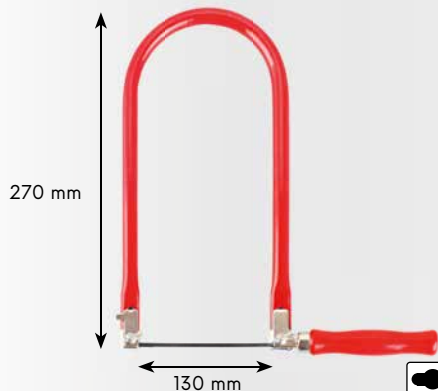

LAUBSÄGEN

Nr.	Spezifikation	
24121	Säge	12
24110	Sägeblatt	30

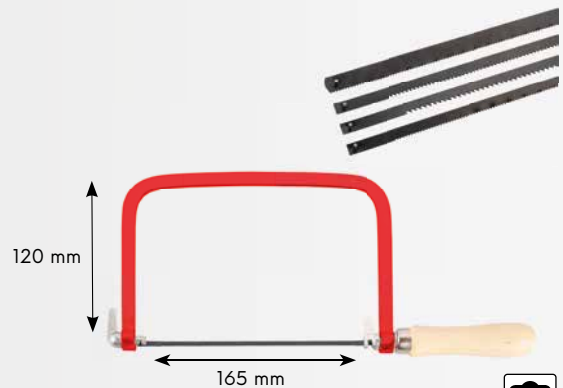

SÄGE

· 5x Sägeblatt

Nr.	Spezifikation	
24122	Säge	20
24111	Sägeblatt	30

FESTA

FUCHSSCHWANZSÄGE

TEFLON · 3 x geschliffene und gehärtete Zähne

Nr.	Spezifikation	
24143	300 mm	12
24144	400 mm	12
24145	500 mm	12



FESTA

ZAPFENSÄGE

TEFLON · 3 x geschliffene und gehärtete Zähne

Nr.	Spezifikation	
24147	300 mm	6



FESTA

LOCHSÄGE

· 3 x geschliffene und gehärtete Zähne

Nr.	Spezifikation	
24149	300 mm	12



FESTA

JAPANSÄGE

SK5 · 3 x geschliffene und gehärtete Zähne

Nr.	Spezifikation	
24134	250 mm 0,5 mm	10



FESTA

JAPANSÄGE

SK5 · 3 x geschliffene und gehärtete Zähne

Nr.	Spezifikation	
24115	260 mm 0,6 mm	10



FESTA

JAPANSÄGE

SK5 · 3 x geschliffene und gehärtete Zähne

Nr.	Spezifikation	
24114	260 mm 0,6 mm	10

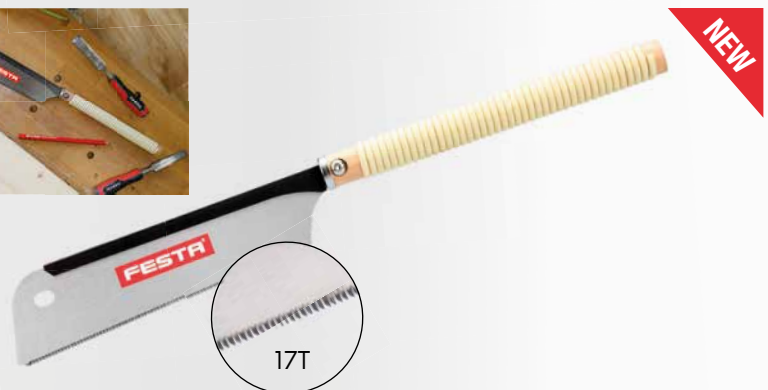

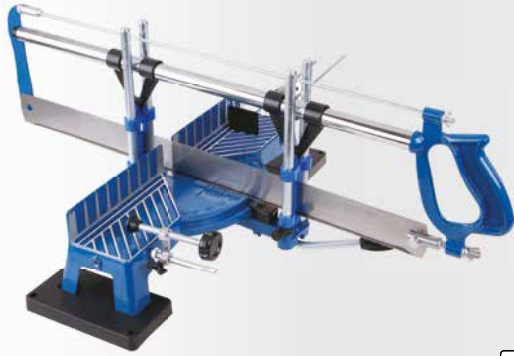

PROFI-GEHRUNGSSÄGE



Nr.	Spezifikation	
24130	600 mm	1
24131	600 mm, Sägeblatt	1



SCHRÄGSCHNITTSÄGE + SÄGE



Nr.	Spezifikation	
24148	300 mm	25

GEHRUNGS-SCHNEIDLADE AUS HOLZ

Buche
MADE IN EU



Nr.	Spezifikation	
24171	80 x 300 mm	10

GEHRUNGS-SCHNEIDLADE AUS KUNSTSTOFF



Nr.	Spezifikation	
24133	300 x 140 mm	18

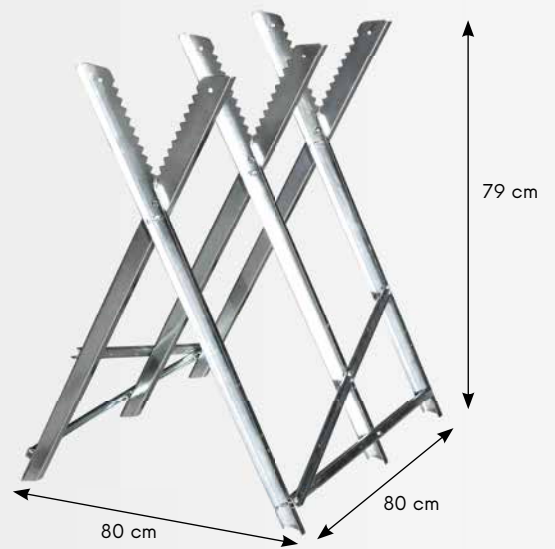

SÄGEBOCK



Nr.	Spezifikation	
37570	max. 150 kg	3

FESTA
BOGENSÄGE

gehärtete Zähne



Nr.	Spezifikation		Nr.	Spezifikation	
24141	450 mm	12	24136	760 mm	12
24140	533 mm	12	24142	800 mm	12
24135	610 mm	12	24137	914 mm	12

FESTA
BOGENSÄGE, DREHBAR

gehärtete Zähne



Nr.	Spezifikation	
24173	350 mm	24

GARTENSÄGE



Nr.	Spezifikation	
24151	300 mm	10

GARTENSÄGE DREHBAR



Nr.	Spezifikation	
24150	300 mm	5

SÄGE

Nr.	Spezifikation	
24128	450 mm Scheiben 24192	6



FESTA

SCHLUSSSÄGE



· 3 x geschliffene und gehärtete Zähne



Nr.	Spezifikation	
45061	150 mm mit Griffabdeckung	12



FESTA

SCHLUSSSÄGE



· 3 x geschliffene und gehärtete Zähne



Nr.	Spezifikation	
45060	180 mm	6



FESTA

SÄGE MIT GEHÄUSE



· 3 x geschliffene und gehärtete Zähne



Nr.	Spezifikation	
45062	260 mm mit Gehäuse	24



ASTSÄGE



· 3 x geschliffene und gehärtete Zähne



Nr.	Spezifikation	
24152	350 mm 6 tpi	12

FESTA

TELESKOPISCHE ASTSÄGE



· 3 x geschliffene und gehärtete Zähne

Nr.	Spezifikation	
45033	230 - 490 mm	1



RAUPENKETTE MIT SÄGE



Nr.	Spezifikation	
45030	Säge 30 cm teleskopische Stange 260 cm	6
45031	Säge 30 cm	6

RAUPENKETTE



Nr.	Spezifikation	
45032	Metall-Raupenkette ohne Säge	6

FESTA

POLYSTYROLSÄGE



Nr.	Spezifikation	
24174	380 mm	1

FESTA

GIPSKARTONSÄGE



3 x geschliffene und gehärtete Zähne



Nr.	Spezifikation	
24159	150 mm	12

FESTA

HOHLZIEGELSÄGE (PORO-THERM)



Nr.	Spezifikation	
24181	550 mm	1

GIPSKARTON-BOHRSÄGE



Nr.	Spezifikation	
24190	270 mm	10

FESTA

PORENBETONSÄGE



Nr.	Spezifikation	
24158	22 22 SK Zähne - 450 mm	5

FESTA

PORENBETONSÄGE



Nr.	Spezifikation	
24155	34 17 SK Zähne - 600 mm	2
24156	34 34 SK Zähne - 600 mm	2

FESTA

PORENBETONSÄGE

gehärtete Zähne



Nr.	Spezifikation	
24175	ohne SK Zähne - 600 mm EU	2
24178	ohne SK Zähne - 600 mm	6

FESTA

PORENBETONSÄGE

Nr.	Spezifikation	
24176	34 17 SK Zähne - 750 mm	6
24177	34 34 SK Zähne - 750 mm	6





FESTA
HAMMER

· Eschestiel

DIN
1041

Nr.	Spezifikation	
19081	100 g	1
19082	200 g	1
19083	300 g	1
19084	400 g	1
19085	500 g	1
19086	600 g	1
19088	800 g	1
19090	1000 g	1
19092	1500 g	1
19095	2000 g	1



FESTA
HAMMER

· Eschestiel

DIN
1041

Nr.	Spezifikation	
19096	3000 g	1
19097	4000 g	1
19098	5000 g	1
19106	6000 g	1
19108	8000 g	1
19109	10000 g	1



FESTA
SCHONHAMMER

· Eschestiel

DIN
6475

Nr.	Spezifikation	
19041	1000 g	1
19042	1250 g	1
19043	1500 g	1
19044	2000 g	1



FESTA
SCHONHAMMER

· Eschestiel

DIN
6475

Nr.	Spezifikation	
19045	3000 g	1
19046	4000 g	1
19074	5000 g	1
19075	6000 g	1
19076	8000 g	1
19077	10000 g	1



FESTA
FIBERGLASSHAMMER

· Fiberglass-Stiel

Č.p.	specifikace	
19021	100 g	12
19022	200 g	12
19023	300 g	12
19024	400 g	12
19025	500 g	12
19026	600 g	6
19028	800 g	6
19030	1000 g	6
19031	1500 g	6
19032	2000 g	1



FESTA
FIBERGLASSSCHONHAMMER

· Fiberglass-Stiel

DIN
6475

Č.p.	specifikace	
19066	1000 g	4
19067	1250 g	4
19068	1500 g	4
19069	2000 g	2



FESTA
FIBERGLASSSCHONHAMMER

· Fiberglass-Stiel

Č.p.	specifikace	
19034	3000 g	4
19036	4000 g	4



FESTA
FIBERGLASSHAMMER

· Fiberglass-Stiel

DIN
6475

Č.p.	specifikace	
19070	3000 g	4
19071	4000 g	4
19058	5000 g	4
19059	6000 g	2

FESTA

**FIBERGLASS-
SCHUSTER-
HAMMER**

· Fiberglass-Stiel



Č.p.	specifikace	
19061	600 g	6



FESTA

**FIBERGLASS-
HAMMER**

· Fiberglass-Stiel

Č.p.	specifikace	
19064	450 g	6



FESTA

**MONOLIT-
DACHDECKER-
HAMMER**



Č.p.	specifikace	
19062	600 g	6



FESTA

**MONOLIT-
SCHUSTER-
HAMMER**

Č.p.	specifikace	
19063	450 g	6



**DACHDECKER-
HAMMER**



Č.p.	specifikace	
19100	600 g	6



FESTA

**MONOLIT-
MAURER-
HAMMER**

Č.p.	specifikace	
19150	600 g	6



FESTA

**DACHDECKER-
HAMMER**



Č.p.	specifikace	
19060	600 g	6



FESTA

**SCHUSTER-
HAMMER**

Č.p.	specifikace	
19065	450 g	6



FESTA

**FIBERGLASS-
MAURERHAMMER**

· Fiberglass-Stiel

Č.p.	specifikace	
19151	600 g	6



FESTA

MAURERHAMMER

· Eschestiel

Č.p.	specifikace	
19149	44 mm	1



FESTA

MAURERHAMMER

· Eschestiel

Č.p.	specifikace	
19124	24 mm	1
19136	36 mm	1
19148	48 mm	1



FESTA

HAMMER - AXT

Č.p.	specifikace	
19303	600 g	6



FESTA

SCHONHAMMER



Č.p.	specifikace	
19051	1000 g	6
19052	1500 g	6

SCHONHAMMER



· Kreiskeil

DIN 6475

Č.p.	specifikace	
19053	1000 g	6
19050	1250 g	6
19054	1500 g	6
19055	2000 g	6



HAMMER

· Kreiskeil

DIN 1041

Č.p.	specifikace	
19001	100 g	12
19002	200 g	12
19003	300 g	6
19004	400 g	6
19005	500 g	6
19006	600 g	6
19008	800 g	6
19010	1000 g	6
19015	1500 g	6
19020	2000 g	6



SCHONHAMMER

· Kreiskeil

DIN 6475

Č.p.	specifikace	
19056	3000 g	6
19057	4000 g	6

SCHWEISSHAMMER



Č.p.	specifikace	
19115	320 g	1



FESTA

ESCHENSTIEL FÜR MAURERHAMMER



Nr.	Spezifikation	
61240	Stiel	1

HAMMERSTIEL AUS ESCHE



Nr.	Spezifikation	für Hammer	
61320	26 cm	19081	10
61321	28 cm	19082	10
61322	30 cm	19083	10
61323	31 cm	19084	10
61324	32 cm	19085	10



SCHONHAMMERSTIEL AUS ESCHE



Nr.	Spezifikation	für Schonhammer	
61330	80 cm	19074, 19075	10
61331	90 cm	19076, 19077	10



KEIL KREISFÖRMIG KONISCH

Nr.	Spezifikation	
19430	6 mm	10
19431	8 mm	10
19432	10 mm	10
19433	12 mm	10
19434	14 mm	10
19435	16 mm	10



KEIL GESCHMIEDET



Nr.	Spezifikation	
19440	schmal	10
19441	mittel	10
19442	breit	10
19443	breites S	10



FESTA

KEIL ZUR AXT



3x

Nr.	Spezifikation	
19398	20 x 25 x 5 mm	1
19399	30 x 40 x 5 mm	1





FESTA



FESTA

HOLZHAMMER

· bukové dřevo



Nr.	Spezifikation	
19202	Ø 60 x 120 mm 260 g	1



FESTA

GUMMIHAMMER

· jasanová násada



Nr.	Spezifikation	
19245	Ø 55 mm 400 g	1
19246	Ø 60 mm 800 g	1
19247	Ø 70 mm 1000 g	1
19248	Ø 95 mm 2000 g	1
19249	Ø 115 mm 3000 g	1

FESTA

GUMMIHAMMER

· Fiberglass-Stiel



Nr.	Spezifikation	
19270	Ø 55 mm	6
19271	Ø 65 mm	6
19272	Ø 90 mm	6



FESTA

GUMMIHAMMER



Nr.	Spezifikation	
19255	Ø 55 mm	6
19265	Ø 65 mm	6
19290	Ø 90 mm	6



FESTA

SCHONHAMMER AUS GUMMI, WEISS

· Fiberglass-Stiel

Nr.	Spezifikation	
19281	680g	6



NEW

FESTA

SCHONHAMMER AUS GUMMI, WEISS



Nr.	Spezifikation	
19293	Ø 55 mm	6
19294	Ø 65 mm	6
19295	Ø 90 mm	6



FESTA

SCHONHAMMER, MESSING

· Fiberglass-Stiel

Nr.	Spezifikation	
19211	Ø 30 mm 500 g	1



FESTA

SCHONHAMMER, NYLON

· Fiberglass-Stiel



Nr.	Spezifikation	
19209	Ø 34 mm	6



GUMMIHAMMER



Nr.	Spezifikation	
19251	Ø 55 mm 400 g	12
19252	Ø 65 mm 700 g	6
19253	Ø 90 mm 1300 g	4



SCHONHAMMER AUS GUMMI, SCHWARZ-WEISS



Nr.	Spezifikation	
19254	Ø 65 mm	6



SCHONHAMMER, SILIKON

Nr.	Spezifikation	
19297	Ø 30 mm	12



FESTA

SCHONHAMMER MIT AUSTAUSCHBAREN ENDEN

- PP - 97 Shore A ·
- TPU - 95 Shore A ·
- TPE - 90 Shore A ·
- TPE - 90 Shore A ·
- TPU - 92 Shore A ·
- TPU - 92 Shore A ·
- TPU - 88 Shore A ·
- TPE - 90 Shore A ·

Nr.	Spezifikation	
19208	Ø 38 mm	1

KLEMPNERSET



7x



5

Nr.	Spezifikation
19110	



FESTA

BRECHSTANGE



Nr.	Spezifikation	Box
19420	300 mm	1



FESTA

BRECHSTANGE

Nr.	Spezifikation	Box
19424	400 mm	6
19425	600 mm	6
19426	800 mm	6
19427	1000 mm	6



BRECHSTANGE

Nr.	Spezifikation	Box
19416	600 mm Ø 16 mm	4
19422	800 mm Ø 16 mm	4
19421	1000 mm Ø 18 mm	4



BRECHSTANGE

Nr.	Spezifikation	Box
19423	380 x 35 x 6 mm	1



FESTA

ABZIEHER
BRECHSTANGE

Nr.	Spezifikation	Box
19415	300 mm Ø 15 mm	6





FESTA

FLACHMEISSEL

CrV	Nr.	Spezifikation	Breite der Spitze	
	19406	300 mm	25 mm	5
	19407	400 mm	30 mm	5



FESTA

SPITZMEISSEL

CrV	Nr.	Spezifikation	
	19408	250 mm	5
	19409	350 mm	5



FESTA

FLACHMEISSEL

CrV	Nr.	Spezifikation	Breite der Spitze	
	19460	300 mm	25 mm	5
	19470	400 mm	30 mm	5



SPITZMEISSEL

Nr.	Spezifikation	
19400	250 mm	5
19403	350 mm	6



FLACHMEISSEL

Nr.	Spezifikation	Breite der Spitze	
19401	250 mm	19 mm	6
19404	350 mm	22 mm	6



FLACHMEISSEL

Nr.	Spezifikation	Breite der Spitze	
19402	250 mm	50 mm	2
19405	350 mm	50 mm	6



FESTA

MEISSEL, KÖRNER, DURCHTREIBER - SET

12x CrV

- 2, 6, 8 mm
- 10, 12, 16 mm
- Ø 1,5-3-4-5-6-8 mm

Nr.	Spezifikation	
19487		4



FESTA

MEISSEL, KÖRNER UND DURCHTREIBER - SET

6x CrV

- 2 x 140, 8 x 115 mm
- 12 x 152, 10 x 142 mm
- Ø 3 x 152, 6 x 152 mm

Nr.	Spezifikation	
19486		10



FESTA

MEISSEL-SET

3x CrV

- 10, 12, 16 mm

Nr.	Spezifikation	
19485		10



FESTA

SCHLOSSER-KREUZMEISSEL

CrV

Nr.	Spezifikation	
19429	200 mm	1



FESTA

FLACHMEISSEL

CrV

Nr.	Spezifikation	Breite der Spitze	
19410	200 mm	20 mm	10
19411	250 mm	25 mm	10
19412	300 mm	25 mm	10
19418	400 mm	25 mm	5
19419	500 mm	25 mm	5



SCHLOSSERMEISSEL, FLACH

CrV

Nr.	Spezifikation	Breite der Spitze	
19436	200 mm	20 mm	15

FESTA

LOCHER - SET

CrV **3x**

Nr.	Spezifikation	
19480	Ø 0,8, 1,5, 2,5 mm	10



FESTA

KÖRNER - SET

CrV **3x**

Nr.	Spezifikation	
19481	Ø 0,8, 1,5, 2,5 mm	10



FESTA

LOCHER - SET

CrV **6x**

Nr.	Spezifikation	
19483	Ø 3, 4, 5, 6, 7, 8 mm	5



FESTA

KÖRNER

CrV

Nr.	Spezifikation	
19477	Ø 2,5 mm	20



FESTA

KÖRNER, AUTOMATISCH

CrV

Nr.	Spezifikation	
19478	Ø 2,5 mm	12



FESTA

DURCHTREIBER

CrV

Nr.	Spezifikation	
19472	Ø 4 mm 150 mm	1
19473	Ø 5 mm 150 mm	1
19474	Ø 6 mm 150 mm	1



GLASSCHNEIDER



Nr.	Spezifikation	
20350	130 mm	12



LOCHER

- 24690 - Ø 2,5 mm
 - Ø 3 mm
 - Ø 4 mm
 - Ø 5 mm
 - Ø 6 mm
 - Ø 7 mm
 - Ø 8 mm
 - Ø 9 mm
 - Ø 10 mm
- 24691 - Ø 2 mm
 - Ø 2,5 mm
 - Ø 3,2 mm
 - Ø 4 mm
 - Ø 4,8 mm
 - Ø 5 mm
 - Ø 6,4 mm
 - Ø 8 mm
 - Ø 9,5 mm
 - Ø 11,1 mm
 - Ø 12,7 mm
 - Ø 14 mm
 - Ø 15,8 mm
 - Ø 19 mm
 - Ø 22 mm



Nr.	Spezifikation	
24690	9 Stck Ø 2,5 - 10 mm	10
24691	15 Stck Ø 2 - 22 mm	5

LOCHEISEN

13x

Nr.	Spezifikation	
24695	Ø 5, 6, 8, 10, 11, 13, 16, 19, 22, 25, 28, 32, 35 mm	5



SCHLAGBUCHSTABEN

Nr.	Spezifikation	
20970	6 mm	5
20971	8 mm	5



ZAHLENSTANZE

Nr.	Spezifikation	
20972	6 mm	5
20973	8 mm	5



SCHNELL-VERSCHLUSS-KLEMMER

Nr.	Spezifikation	
23625	150 mm	6
23626	300 mm	6
23628	450 mm	6
23630	600 mm	6
23632	760 mm	6



NEW



VERLÄNGERUNGSKUPPLUNG FÜR KLEMMEN

FESTA INDUSTRY 23625, 23626, 23628, 23630

2x

Nr.	Spezifikation	
23635		6



SCHNELL-VERSCHLUSS-KLEMMER



Nr.	Spezifikation	
23570	100 x 80 mm	1
23571	160 x 80 mm	1
23572	200 x 80 mm	1
23573	250 x 80 mm	1
23574	300 x 80 mm	1

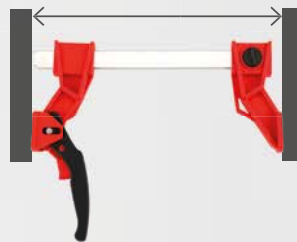

SCHRAUBZWINGE

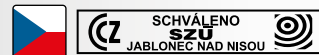

Nr.	Spezifikation	
23670	150 x 105 mm	1
23671	200 x 105 mm	1
23672	250 x 105 mm	1
23673	300 x 105 mm	1
23674	350 x 105 mm	1
23675	400 x 175 mm	1
23676	500 x 175 mm	1
23677	600 x 175 mm	1
23678	700 x 175 mm	1
23679	800 x 175 mm	1
23680	1000 x 175 mm	1
23681	1250 x 175 mm	1
23682	1500 x 175 mm	1
23683	1750 x 175 mm	1
23684	2000 x 175 mm	1
23685	2200 x 175 mm	1



SCHNELL-VERSCHLUSS-KLEMMER

Nr.	Spezifikation	
23585	150 mm	6
23587	300 mm	6
23589	450 mm	6
23591	600 mm	6



FESTA

SCHNELL-VERSCHLUSS-KLEMMER

· kovaná



Nr.	Spezifikation	
23560	200 x 80 mm	1
23561	300 x 100 mm	1
23562	400 x 100 mm	1
23563	500 x 120 mm	1
23564	600 x 120 mm	1
23565	800 x 120 mm	1
23566	1000 x 120 mm	1



KLEMMER

DIN 5117

Nr.	Spezifikation	
23506	300 x 120 mm	10
23507	500 x 120 mm	10
23508	800 x 120 mm	6



KLEMMER

Nr.	Spezifikation	
23515	150 x 50 mm	50
23520	200 x 50 mm	50
23525	250 x 50 mm	50
23530	300 x 50 mm	50
23531	300 x 120 mm	20
23551	500 x 120 mm	10



NEW



FESTA

SVĚRKA PRO PRACOVNÍ STOLY

Nr.	Spezifikation	
23595	250/Ø 20 mm 60 kg	1



NEW



FESTA

SVĚRKA PRO PRACOVNÍ STOLY

Nr.	Spezifikation	
23598	120/Ø 20 mm 70 kg	1

NEW



FESTA

RAHMENSPANNER

Nr.	Spezifikation	
23637	4m x 25mm	1





FESTA

90°-ECKKLEMME



4x

Nr.	Spezifikation	
23607	Spannkraft - 250 N	1



ALU

Bereich 0 - 65 mm



Nr.	Spezifikation	
23420	65 mm	20



KLEMME MIT ZAHNSPERRE

Teilung 80 mm

Nr.	Spezifikation	
23605	9' 230 mm	6



KUNSTSTOFF-KLEMME

Nr.	Spezifikation	
23600	4', Teilung 40 mm	20
23601	6', Teilung 70 mm	12
23602	9', Teilung 100 mm	20



'G' KLEMMENSET

Nr.	Spezifikation	
23620	25 mm, 50 mm, 75 mm	10



FESTA



WERKSTATT

208 - 243



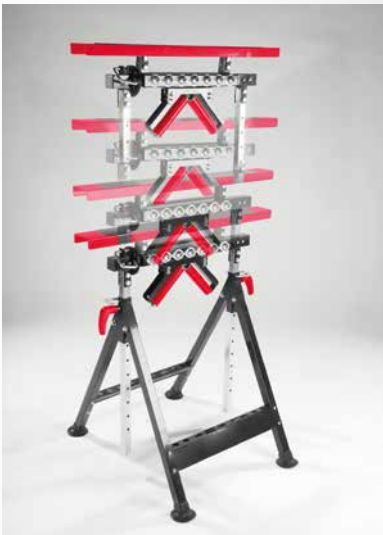

max 200 kg



max 45 kg



max 100 kg



max 100 kg



FESTA

ARBEITSBOCK/WERKAUFLAGE

· max. Belastung: 200 kg

Nr. Spezifikation
36410

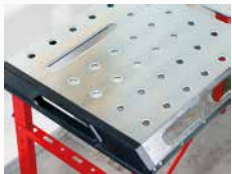

FESTA

**SCHWEISSTISCH
KLAPPBAR**

· max. Belastung: 450 kg

Nr. Spezifikation
23652



FESTA

FALTBARER BOCK

· max. Tragkraft: 590 kg

Č.p. Spezifikace
23657



NEW



2x



4x

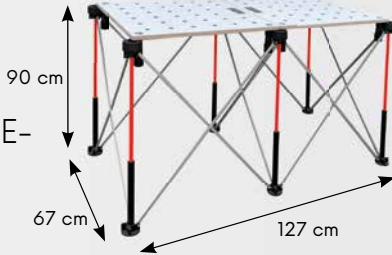

FESTA

CENTIPEDE TRAGBARER MONTAGE-STÄNDER, KOMPATIBEL MIT 23664

- 1270 x 670 x 900 mm
- max. Belastung: 1100 kg



1

Nr. Spezifikation
23661

NEW



FESTA

ARBEITSPLATTE, KOMPATIBEL MIT 23661

- 1200 x 600 x 18 mm



1

Nr. Spezifikation
23664



FESTA

ARBEITSBOCK/WERKAUFLAGE

- max. Belastung: 230 kg



1

Nr. Spezifikation
23658

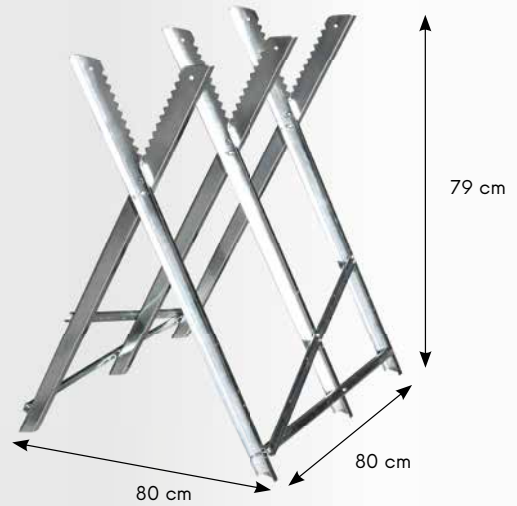

SÄGEBOCK

- max. Belastung: 150 kg



1

Nr. Spezifikation
37570



BAUABSTÜTZUNG

- max. Belastung: 125 kg



1

Nr. Spezifikation
36300



FALTBARER KUNSTSTOFFBOCK

- max. Tragkraft 150 kg (paarweise 300 kg)

2x



1

Nr. Spezifikation
37560

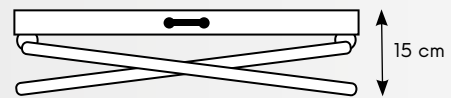
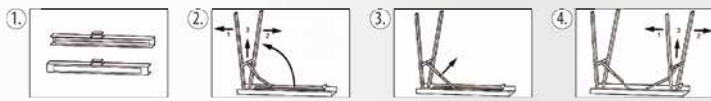
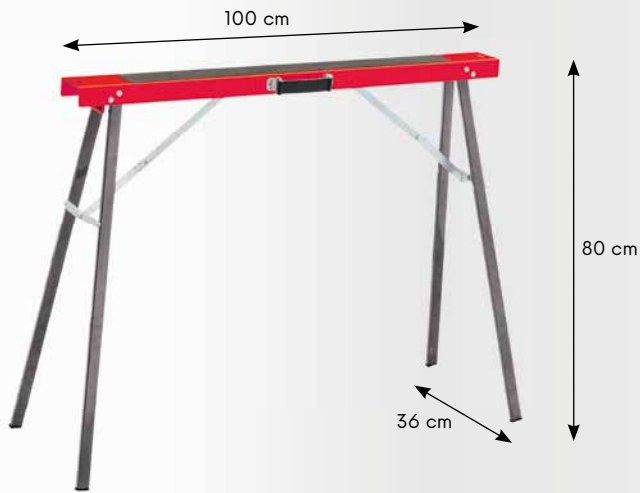

FALTBARER BOCK

· max. Tragkraft 125 kg

2x			
Nr.	Spezifikation		
37549	Paar	1	

ARBEITSTISCH

· Maximale Last 100 kg

Nr.	Spezifikation		
23655	100 x 50 x 84 cm	1	



ARBEITSTISCH

· Ideal für Kellerräume

Nr.	Spezifikation		
23660		1	



ARBEITSTISCH, MULTIFUNKTIONELL

· max. Belastung: 100 kg

Nr.	Spezifikation		
23650		1	



MONTAGESITZ

· gepolsterter Rollstuhl mit Ablagefach aus Kunststoff.

Nr.	Spezifikation		
26988	360 x 365 x 365 mm	1	

FESTA
MAGNETHALTERUNG



Nr.	Spezifikation		
70098		12	



FESTO

WERKZEUGWAGEN

Nr.	Schubladenauszüge	Schubladen	Gesamtmaße (mm)	
26986	Gleit-	7	680 x 460 x 1020 mm	1



WERKZEUGWAGEN

- der obere Schrank kann im unteren Wagen verstaut werden

Nr.	Spezifikation	Schubladenauszüge	Schubladen	Schubladen-Innenmaße BxTxH	Gesamtmaße	Gesamtgewicht (kg)	
26985	Oberschrank	Gleit-	3	151,5 x 225 x 40 mm	600 x 260 x 340 mm	11,5 kg	1
			2	511 x 225 x 40 mm			
	Unterschrank	Gleit-	1	511 x 225 x 85 mm	616 x 330 x 742 mm	16,4 kg kg	
			2	511 x 308 x 85 mm			

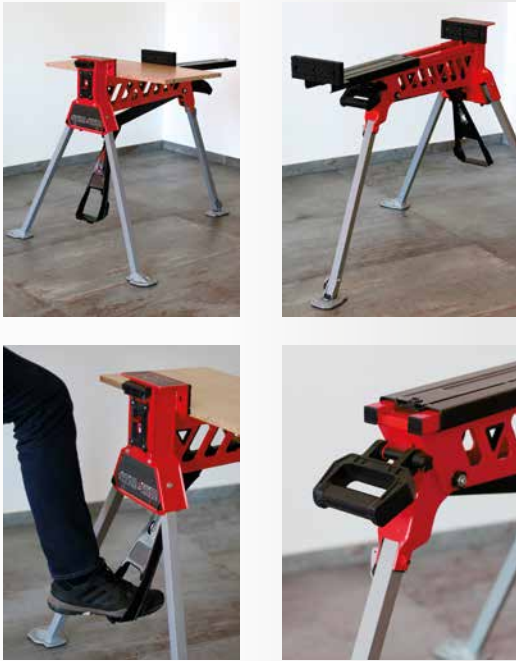

FESTA

TRAGBARER SCHRAUBSTOCK

- Backenbereich: 0 - 95 cm
- max. Tragkraft: 250 kg



1

Č.p. Spezifikace
37553



FESTA

SCHRAUBSTOCK

- gehärtete Backen

Nr.	Spezifikation	
23410	100 mm	1
23411	125 mm	1
23412	150 mm	1



DREH-SCHRAUBSTOCK

- gehärtete Backen

Nr.	Spezifikation	
23415	100 mm	1
23416	125 mm	1
23417	150 mm	1



DREH-SCHRAUBSTOCK

Nr.	Spezifikation	
23407	65 mm	10



BOHRMASCHINEN-SCHRAUBSTOCK

- gehärtete Backen

Nr.	Spezifikation	
23400	18 80 mm	10
23401	22 100 mm	10
23402	24 125 mm	5

360° DREHBARER MODELLMACHER-SCHRAUBSTOCK, ZUM AUFSTELLEN AUF DEN TISCH



ALU	Spezifikation	
23406	80 mm	24

HYDRAULISCHER WAGENHEBER, EINZELKOLBEN

- verstellbare Schraube ermöglicht Feineinstellung der Höhe und maximalen Hub
- doppeltes Sicherheitsventil
- großer gerändelter Sitzbereich für sicheren Halt
- breiter Sockel für Stabilität und Haltbarkeit
- alle stark beanspruchten Stellen sind für erhöhte Haltbarkeit und Langlebigkeit verstärkt



Nr.	Tragfähigkeit	Min. Höhe	Hub	feine Höhenverstellung	Abmessungen Grundgestell	Gewicht	
26800	2 000 kg	181mm	116 mm	48 mm	88 x 92 mm	2,6 kg	1
26801	3 000 kg	194 mm	118 mm	60 mm	92 x 100 mm	3,3 kg	1
26802	5 000 kg	216 mm	127 mm	70 mm	96 x 112 mm	4,5 kg	1
26803	8 000 kg	230 mm	147 mm	80 mm	103 x 118 mm	5,7 kg	1
26804	10 000 kg	230 mm	150 mm	80 mm	110 x 123 mm	6,8 kg	1
26805	12 000 kg	230 mm	155 mm	80 mm	116 x 134 mm	7,3 kg	1
26806	15 000 kg	230 mm	150 mm	80 mm	133 x 136 mm	8,4 kg	1
26807	20 000 kg	242 mm	150 mm	60 mm	144 x 152 mm	11 kg	1



HYDRAULISCHER WAGENHEBER, ZWEIKOLBEN

- verstellbare Schraube ermöglicht eine feine Höheneinstellung und einen maximalen Hub.
- doppeltes Sicherheitsventil.
- großer gerändelter Sitzbereich für sicheren Halt.
- der breite Sockel sorgt für Stabilität und Haltbarkeit.
- alle stark beanspruchten Stellen sind verstärkt, um die Haltbarkeit und Langlebigkeit zu erhöhen.



Nr.	Tragfähigkeit	min. Höhe	Hub	feine Höhenverstellung	Gewicht	
26815	2 000 kg	150 mm	160 mm	60 mm	4,7 kg	1
26816	4 000 kg	160 mm	170 mm	60 mm	6,4 kg	1
26817	6 000 kg	215 mm	270 mm	-	8,9 kg	1
26819	10 000 kg	228 mm	284 mm	89 mm	10,2 kg	1



SCHERENHEBER



Nr.	Tragfähigkeit	Min. Höhe	max. Höhe	Gewicht	
26844	1 000 kg	88 mm	380 mm	2,5 kg	1
26845	2 000 kg	120 mm	395 mm	3,5 kg	1



HYDRAULIK-RANGIER-WAGENHEBER



Nr.	Spezifikation	Tragfähigkeit	Min. Höhe	max. Höhe	Gewicht	
26820	Hydraulischer Wagenheber, mobil, tragbar	2 000 kg	130 mm	345 mm	9,6 kg	1
26822	Hydraulischer Wagenheber, mobil, tragbar	3 000 kg	130 mm	465 mm	27,4 kg	1
26826	Hydraulischer Wagenheber mobil, niedriges Profil, 360° drehbarer Griff	2 000 kg	89 mm	359 mm	14,2 kg	1
26824	Hydraulischer Wagenheber, Werkstatt, Fußpedal	3 000 kg	145 mm	500 mm	37,2 kg	1
26825	Hydraulischer mobiler Wagenheber, Werkstatt, niedriges Profil, profi	2 500 kg	85 mm	455 mm	34,8 kg	1

HYDRAULIK-RANGIER-WAGENHEBER + STÜTZEN

· 360° drehbare Steuerstange



Nr.	Tragfähigkeit	Min. Höhe	max. Höhe	Gewicht	
26829	2 000 kg	130 mm	350 mm	10,5 kg	1
	2 000 kg	275 mm	420 mm	5 kg (pair)	

VERSTELLBARE STÜTZE

- 1 St. = 1 Paar
- Kamm für präzise Höheneinstellung mit doppelter Verriegelung
- massiver Stahlgriff
- große Sitzfläche, stabile Rahmenkonstruktion
- Stützteil aus Gusseisen



Nr.	Spezifikation	Tragfähigkeit	Min. Höhe	max. Höhe	Gewicht	
26857	mit Sicherheitsverschluss	2 000 kg	275 mm	420 mm	4,8 kg	1
26858	mit Sicherheitsverschluss	3 000 kg	285 mm	425 mm	6,3 kg	1
26859	mit Sicherheitsverschluss	6 000 kg	393 mm	593 mm	13 kg	1
26853		12 000 kg	465 mm	715 mm	28 kg	1

HYDRAULISCHER KRANWAGENHEBER, KLAPPBAR

- zum Heben und Lagern von Aggregaten bei der Montage und Demontage
- der Tragarm hat mehrere Ausfahrpositionen und die Tragfähigkeit des Krans wird entsprechend gesteuert
- durch die klappbare Konstruktion nimmt der Kran im Ruhezustand nur wenig Platz ein

Nr.	Tragfähigkeit	Min. Höhe	max. Höhe	Gewicht	
26862	2 000 kg	0	2360 mm	88 kg	1



MOTORSTÜTZHALTERUNG

- Pendelaufhängung des Auslegerarms in Abhängigkeit von der Neigung der Motorhaube, gewährleistet jederzeit eine ausgewogene und stabile Motorbefestigung

Nr.	Tragfähigkeit	Dauer	Umfang	Gewicht	
26871	500 kg	1500 mm	150 mm	20,3 kg	1



HYDRAULISCHER GETRIEBEHEBER

- einfache Montage und Demontage von Aggregaten (Motoren, Getriebe, Achsen usw.)

Nr.	Spezifikation	Tragfähigkeit	Dauer	Umfang	Gewicht	
26880	Hydraulischer Getriebeheber	500 kg	1100 mm	1900 mm	30,0 kg	1



26880

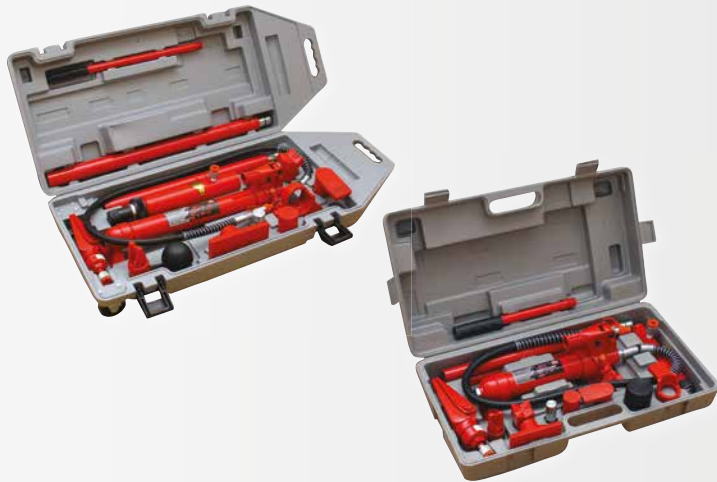

DEHNUNGSSET

- hydraulische Geräte für die Reparatur von Fahrzeugkarosserien
- besteht aus einem hydraulischen Expansionszylinder und 14 Teilen Zubehör
- eine breite Palette von Anwendungen in der Karosseriereparatur von PKWs, Kleintransportern und LKWs, vor allem an Orten, wo es keine Möglichkeit des Anschlusses an Energiequellen gibt
- das Gerät kann zum Expandieren, Komprimieren, Heben und Dehnen in vertikaler und horizontaler Richtung verwendet werden
- leicht zu transportieren im Kunststoffkoffer



Nr.	Tragfähigkeit	Hydraulischer Hub	Gewicht	
26886	4 000 kg	125 mm	17,0 kg	1
26888	10 000 kg	135 mm	32,0 kg	1



MOTORSTÄNDER

- mobiler Ständer für die Montage und die Arbeit an demontierten Motoren
- universal-Klemmeinheit ermöglicht sowohl das Klemmen des Motors als auch dessen Drehung



Nr.	Tragfähigkeit	Gewicht	
26920	450 kg	20 kg	1



26897



26943

FEDERSPANNER

- 26897 - für den Ausbau von McPherson-Federn direkt am Fahrzeug.

- 26943 - für den Ausbau von McPherson-Federn außerhalb des Fahrzeugs massive Stahlprofile für mehr Stabilität.



Nr.	Last	Ø Druckfeder	Kompressionsbereich	Gewicht	
26897	1 000 kg	100-200 mm	150 mm	24,5 kg	1
26943	1 000 kg	400 mm	210-570 mm	35 kg	1

AUSPUFFÖLABSAUGUNG

- das Öl wird aus dem Motor in die Auffangwanne abgelassen, von wo es in den Behälter fließt
- der Container ist zusätzlich mit einer pneumatischen Absaughaube ausgestattet
- die Entleerung des Tanks erfolgt pneumatisch durch Anschluss an Druckluft



Nr.	Volumen	max. Druck	Gewicht	
26954	90 l	0,5 MPa	28 kg	1



HYDRAULISCHE ROHRBIEGEMASCHINE

Nr.	Last	Hub	biegefähige Kniestücke	Gewicht	
26895	12 000 kg	232 mm	1 2", 3 4", 1", 1-1 4", 1-1 2", 2"	36 kg	1
26896	16 000 kg	238 mm	1 2", 3 4", 1", 1-1 4", 1-1 2", 2", 2-1 2", 3"	65 kg	1



HYDRAULIKPRESSE

Nr.	Umfang	max. Belastung	Gewicht	
26940	0 - 610 mm	12 000 kg	43 kg	1
26941	0 - 880 mm	20 000 kg	75 kg	1

HYDRAULIKZYLINDER



Nr.	Spezifikation	Last	min. Länge (mm)	max. Länge (mm)	Gewicht	
26911	Einzelpumpe	5 000 kg	620	1100	12 kg	2
26912	Einzelpumpe	8 000 kg	620	1100	13 kg	2
26914	Doppelpumpe	5 000 kg	620	1100	12 kg	2
26915	Doppelpumpe	8 000 kg	620	1100	14 kg	2

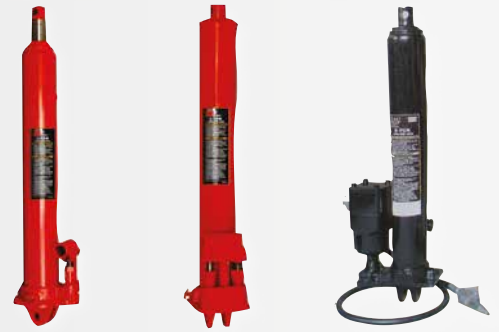

ERSATZTEILE FÜR SANDSTRAHLKABINE

Nr.	Spezifikation	
26973	Handschuhe	1
26974	Düsen	1
26975	Folie 53,5 x 26 cm	1
26976	Plexiglas 60 x 30 cm	1
26977	Glas 60 x 30 cm	1

SANDSTRAHLKABINE 220 L

Nr.	Luftverbrauch	Außenmaße	Maße innen	max. Druck	Gewicht	
26972	420-710 l/min.	1500 x 830 x 630 mm	600 x 840 x 630 mm	8 bar	38 kg	1



TEILEWASCHANLAGE

- für das normale Waschen von Gegenständen (Teile, Maschinenteile usw.)



Nr.	Volumen der Wanne	Volumen der Reinigungsflüssigkeit	Durchfluss	Max. Temperatur der Reinigungsflüssigkeit	Gewicht	
26961	90 l	45 l	10-12 l/min.	50°C	25 kg	1
26963	180l	150 l	20 l/min	50°C	42 kg	1



ÖLER

Nr.	Spezifikation	
50020	300 ml	10



SCHMIERBUCHSE

- Direktbefüllung
- Kartuschenbefüllung
- Pumpenbefüllung

Nr.	Spezifikation	
50022	400 ml	20

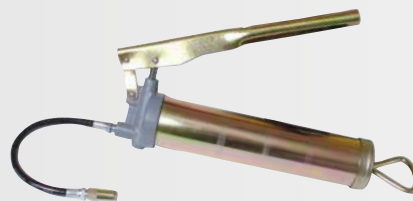

FASSPUMPE

Nr.	
50017	10





ÖLER

Nr.	Spezifikation	
50019	90 ml	1



FILTERLOCKERER

Nr.	Spezifikation	
50021	60 x 140 mm	6



TRICHTER

Nr.	Spezifikation	
50025	60 x 140 mm	50



ÜBERLAUFSCHLAUCH
MIT SELBSTANSAUGENDEM
VENTIL

Nr.	Dauer	Ø	
50026	180 cm	15 mm	24



MAGNETSCHALE

Nr.	Spezifikation	
26996	200 x 20 mm	1

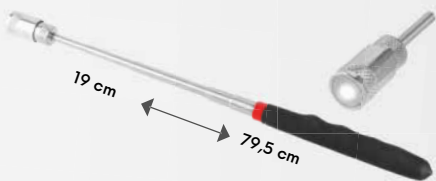

FESTA

MAGNETTELESKOP
MIT LED-BELEUCHTUNG



Nr.	Spezifikation	
13294	3x LR44	6

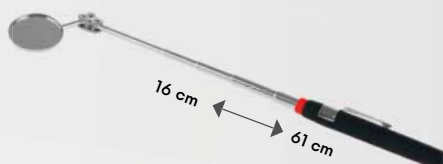

TELESKOPISCHER
INSPEKTIONSSPIEGEL

Nr.	Spezifikation	
13290		20

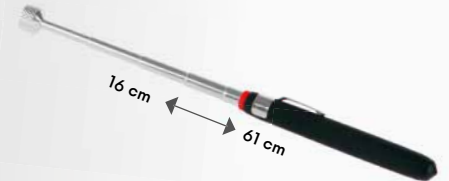

MAGNETISCHES TELESKOP



Nr.	Spezifikation	
13293		20



MÜLLSAMMLER

· um 90° drehbar

Nr.	Dauer	
61235	81 cm	12

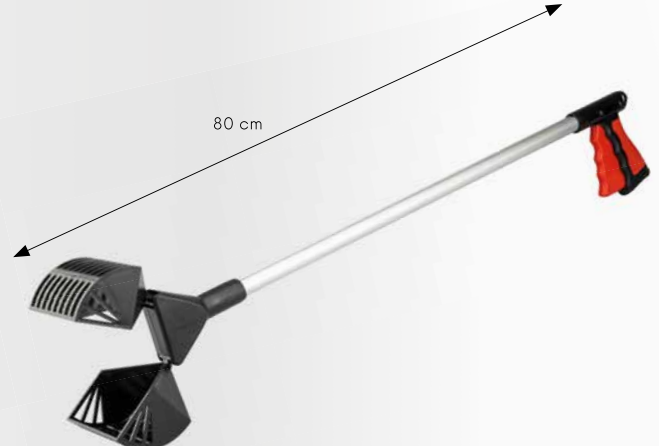

MÜLLSAMMLER

· max. 4 kg

Nr.	
61236	12

FESTA



NEW



FESTA
INDUSTRY

LED-LEUCHTE

3xLED	80, 200, 300 lm	3W COB LED	USB TYPE C	Li-ion 3.7V 0.8Ah	120 min
95g	0-180°	IK07	IP54		

Nr. **37647** Spezifikation **3,7V 800 mAh**





FESTA

LED-LEUCHTE



MOQ
12

Nr.	Spezifikation
37645	200 mm 3 x AAA 12

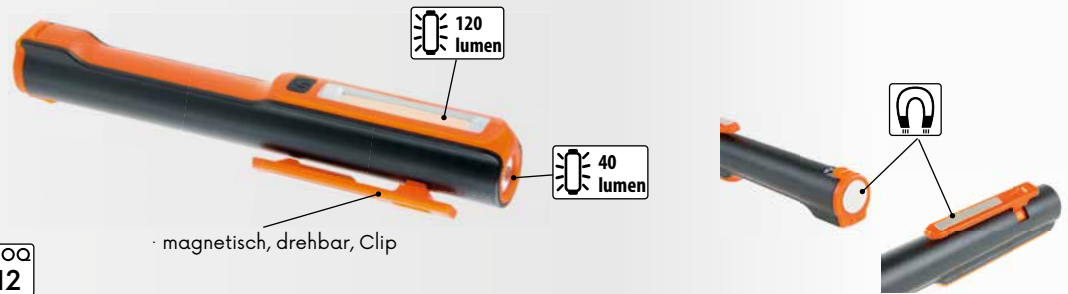

FESTA

LED-STIRNLAMPE

Gewicht	47 g
Lichtquelle	1 x 1 W white LED + 2x red LED
Batterie	3 x AAA
Abm.	40 x 59 x 32 mm
Leuchtdauer:	45 h
Lichtfluss	120 lumen
Nachleuchtdauer	60 m (100% battery)
Leuchtmodi	4

5 Kipppositionen

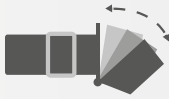

Nr.	Spezifikation
37641	120 Lumen + rotes Licht 1

FESTA

LED LEUCHTE

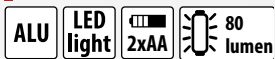

Nr.	Spezifikation
37630	185 mm 2 x AA 20



FESTA

LED LEUCHTE



Nr.	Spezifikation
37650	12



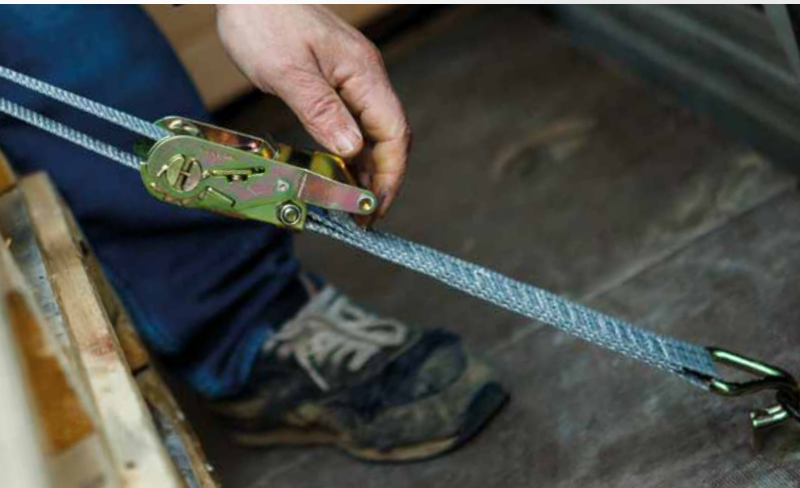

FESTA

SPANNGURTE SELBSTAUF-ROLLEND



2x



Nr.	Breite	Dauer	Tragfähigkeit	St.	
51070	18 mm	2 m	100 kg	2	12

FESTA

SELBSTAUF-ROLLENDES SPANNBAND



Nr.	Breite	Dauer	Tragfähigkeit	St.	
51071	25 mm	3,5 m	300 kg	1	8



FESTA

SELBSTAUF-ROLLENDES SPANNBAND



Nr.	Breite	Dauer	Tragfähigkeit	St.	
51072	35 mm	4 m	500 kg	1	6



FESTA

SPANNBAND



Nr.	Breite	Dauer	Tragfähigkeit	St.	
51040	25 mm	6 m	1000 kg	1	1
51041	35 mm	8 m	2000 kg	1	1
51042	35 mm	8 m	3000 kg	1	1
51043	50 mm	10 m	5000 kg	1	1



FESTA

SPANNBÄNDER



2x

Nr.	Breite	Dauer	Tragfähigkeit	St.	
51060	25 mm	5 m	750 kg	2	5



FESTA

SPANNBAND



Nr.	Breite	Dauer	Tragfähigkeit	St.	
51065	50 mm	10 m	960 kg	1	6



FESTA

SPANNBAND



Nr.	Breite	Dauer	Tragfähigkeit	St.	
51026	75 mm	5 m	3000 kg	1	4

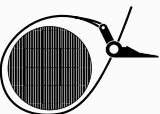

FESTA

SPANNBAND



Nr.	Breite	Dauer	Tragfähigkeit	St.	
51032	25 mm	5 m	500 kg	1	6



FESTA

SPANNBAND



Nr.	Breite	Dauer	Tragfähigkeit	St.	
51017	50 mm	6 m	480 kg	2	5
51018	50 mm	6 m	480 kg	1	10



SPANNBAND



Nr.	Breite	Dauer	Spezifikation	St.
51022	25 mm	5 m	mit Haken	40
51023	50 mm	5 m	mit Haken	12

FESTA
SPANNBAND



weiche EVA-Unterlage

Nr.	Breite	Dauer	St.
51046	38 mm	4 m	1 20

SPANNBAND



Nr.	Breite	Dauer	Spezifikation	St.
51030	50 mm	6 m	mit Haken	20
51034	50 mm	8 m	mit Haken	10

SPANNBÄNDER



2x

Nr.	Breite	Dauer	St.
51020	25 mm	2,5 m	2 100

SPANNBAND



PE

Nr.	Breite	Dauer	St.
51045	25 mm	4 m	1 50

EINSTELLBARE SPANNGUMMIS



2x

Nr.	Dauer	Ø	St.
51013	1,2 m	8 mm	2 1

SPANNGUMMIS



2x

Nr.	Dauer	St.
51008	1 m	2 25

SPANNGUMMI MIT KARABINERHAKEN



Nr.	Dauer	Ø	St.
51009	1 m	10 mm	1 25

SPANNSCHRAUBENSET



8x

- 2 x 0,4 m
- 2 x 0,6 m
- 1 x 0,8 m
- 1 x 1,0 m

Nr.	Dauer	Ø	St.
51011	1 m	8 mm	8 10

SPANNGUMMIS



2x

Nr.	Dauer	Ø	St.
51001	80 cm	10 mm	2 50
51002	100 cm	10 mm	2 50
51003	150 cm	10 mm	2 50
51004	200 cm	10 mm	2 50

SPANNGUMMIS MIT HAKEN



2x

Nr.	Dauer	Ø	St.
51007	1 m	8 mm	2 25

SPANNGUMMIS - SPINNE



Nr.	Dauer	Ø	Spezifikation	St.
51010	80 cm	8 mm	8 Arme	50

FLEXIBLES BEFESTIGUNGSNETZ MIT HAKEN



Nr.	Dauer	Breite	
51015	80 cm	120 cm	20

ELASTISCHES SEIL



Nr.	Dauer	Ø	
51036	20 m	8 mm	10
51037	20 m	10 mm	6

HAKEN FÜR SPANNGUMMIS



20x

Nr.	Ø	
51038	10 mm	30

KARABINER



ALU

MOQ 2

Nr.	Ø	Dauer	
51200	6 mm	60 mm	2
51202	7 mm	70 mm	2
51201	8 mm	80 mm	2
51203	10 mm	100 mm	2

INDUSTRIESEIL



Nr.	Dauer	Ø	
50915	5 m	8 mm	1
50916	25 m	8 mm	1
50917	25 m	10 mm	1
50918	25 m	12 mm	1
50919	25 m	14 mm	1

SILONKORDEL



Nr.	Dauer	Ø	
51055	80 m	1,5 mm	50
51056	50 m	2 mm	50
51057	20 m	4 mm	50

SILONSEIL



Nr.	Dauer	Ø	
51050	50 m	8 mm	10
51051	50 m	10 mm	4

SCHNUR POLYPROPYLEN



Nr.	Gewicht	
50905	80 g	80
50906	100 g	100
50907	200 g	50

SCHNUR POLYPROPYLEN



Nr.	Gewicht	
50909	500 g (250 m)	1
50910	1000 g (500 m)	1
50911	5000 g (2500 m)	1

JUTEKORDEL



Nr.	Gewicht	
50900	80 g (61 m)	1
50901	100 g (76 m)	1
50902	200 g (153 m)	1

WACHSKORDEL



Nr.	Dauer	Ø	
50920	50 m	1 mm	80

SÄCKEBINDER



1000x

Nr.	Spezifikation	
42365	1,25 100 mm	1
42366	1,25 125 mm	1
42367	1,25 140 mm	1
42368	1,25 160 mm	1

SÄCKEBINDER



Nr.	Spezifikation	
50052		12
50050		1

BINDEMittel FÜR KABELBÄUME



Nr.	Spezifikation	
50051		2

BINDUNGSBÄNDER

50x · EN 50146 · nylon

Nr.	Dauer	Breite	
23875	120 mm	4,8 mm	1



BINDUNGSBÄNDER FARBIG

100x · EN 50146 · nylon

Nr.	Dauer	Breite	
23880	100 mm	2,5 mm	1
23882	150 mm	2,5 mm	1
23884	200 mm	3,6 mm	1



BINDUNGSBÄNDER WEISS

50x · EN 50146 · nylon

Nr.	Dauer	Breite	
23850	120 mm	2,5 mm	1
23854	200 mm	3,6 mm	1
23856	250 mm	3,6 mm	1
23858	250 mm	4,8 mm	1
23860	300 mm	4,8 mm	1
23864	400 mm	4,8 mm	1
23866	500 mm	4,8 mm	1
23868	400 mm	7,6 mm	1
23870	500 mm	7,6 mm	1



BINDUNGSBÄNDER SCHWARZ

50x · EN 50146 · nylon

Nr.	Dauer	Breite	
23810	120 mm	2,5 mm	1
23814	200 mm	3,6 mm	1
23816	250 mm	3,6 mm	1
23818	250 mm	4,8 mm	1
23820	300 mm	4,8 mm	1
23824	400 mm	4,8 mm	1
23826	500 mm	4,8 mm	1
23828	400 mm	7,6 mm	1
23830	500 mm	7,6 mm	1



BINDUNGSBÄNDER MIT GRIF

10x

Nr.	Dauer	Breite	
23865	160 mm	7,5 mm	1



SCHRUMPFOLIE

Nr.	Breite	Dauer	Materialfestigkeit	
38095	500 mm	600 m	8 µm klar	1
38097	100 mm	150 m	20 µm klar	1
38096	500 mm	200 m	23 µm schwarz	1



PE-SCHUTTSÄCKE TRANSPARENT

Nr.	Breite	Dauer	Stärke	Volumen	St.	
39194	500 mm	1100 mm	0,16 mm	100 l	1	10
39196	600 mm	1200 mm	0,16 mm	110 l	1	10
39198	700 mm	1100 mm	0,16 mm	120 l	1	10
39200	500 mm	1100 mm	0,20 mm	100 l	1	10
39202	600 mm	1200 mm	0,20 mm	110 l	1	10
39204	700 mm	1100 mm	0,20 mm	120 l	1	10



PE-SCHUTTSÄCKE SCHWARZ

Nr.	Breite	Dauer	Stärke	Volumen	St.	
39195	500 mm	1100 mm	0,16 mm	100 l	1	10
39197	600 mm	1200 mm	0,16 mm	110 l	1	10
39199	700 mm	1100 mm	0,16 mm	120 l	1	10
39201	500 mm	1100 mm	0,20 mm	100 l	1	10
39203	600 mm	1200 mm	0,20 mm	110 l	1	10
39205	700 mm	1100 mm	0,20 mm	120 l	1	10



MÜLLSÄCKE

Nr.	Breite	Dauer	Stärke	St.	
38060	700 mm	1100 mm	0,08 mm	10	1
38063	700 mm	1100 mm	0,10 mm	3	1
38065	700 mm	1100 mm	0,20 mm	3	1



ABFALLBEUTEL

Nr.	Breite	Dauer	Stärke	St.	
38050	500 mm	600 mm	0,04 mm	25	1
38052	600 mm	800 mm	0,04 mm	25	1
38054	700 mm	1100 mm	0,04 mm	25	1



PE-MÜLLSÄCKE

5x

Nr.	Breite	Dauer	Stärke	
38055	1200 mm	1000 mm	0,08 mm	5

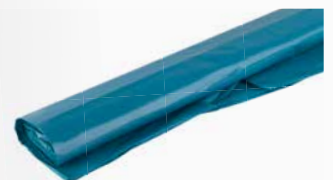



WARNFOLIE - EL. VERKABELUNG

Nr.	Breite	Dauer	
38955	22 cm	20 m	1
38956	22 cm	50 m	1



WARNFOLIE - WASSER

Nr.	Breite	Dauer	
38957	22 cm	20 m	1
38958	22 cm	50 m	1



WARNFOLIE - GAS

Nr.	Breite	Dauer	
38959	22 cm	20 m	1
38960	22 cm	50 m	1



WARNBAND

Nr.	Spezifikation	Dauer	
38944	ZÁKAZ VSTUPU, SK	80 mm 250 m	8
38945	VSTUP ZAKÁZÁN, CZ	80 mm 250 m	8



WARNBAND

Nr.	Dauer	
38948	80 mm 250 m	8

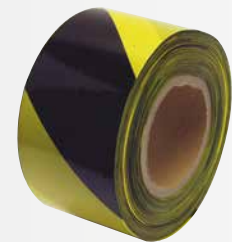

WARNBAND

Nr.	Dauer	
38946	80 mm 250 m	8



WARNBAND - SELBSTKLEBEND

Nr.	Dauer	Spezifikation	
38947	48 mm 33 m	rechts	48
38961	48 mm 33 m	linSt.	48



TRASSENBAND

Nr.	Breite	Dauer	Werkstoffdicke	
38949	50 mm	50 m	0,15 mm	36

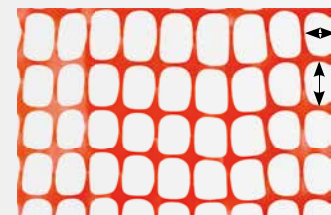

cca 3,5 cm

cca 6,5 cm

SICHERHEITSNETZ

140 g/m² UV STABLE

Nr.	Spezifikation	
42190	1,2 x 50 m HDPE 140g/m ²	1



PVC-BÄNDER

5x

Nr.	Breite	Dauer	Werkstoffdicke	
38931	19 mm	5 m	0,13 mm	100



PVC-BAND SCHWARZ

Nr.	Breite	Dauer	Werkstoffdicke	
38932	19 mm	10 m	0,13 mm	10



PVC-BAND

Nr.	Breite	Dauer	Werkstoffdicke	
38925	19 mm	10 m	0,13 mm	10



PVC-BAND, SCHWARZ

Nr.	Breite	Dauer	Werkstoffdicke	
38968	19 mm	10 m	0,19 mm	10

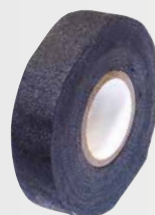

TEXTILBAND SCHWARZ

Nr.	Breite	Dauer	
38927	19 mm	10 m	10

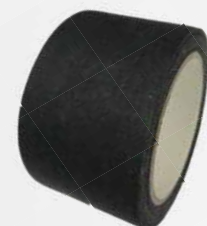

TEXTILBAND, TEPPICHBAND

Nr.	Breite	Dauer	
38980	48 mm	10 m	24
38981	48 mm	20 m	24



DOPPELSEITIGES KLEBEBAND MIT VERSTÄRKUNG

Nr.	Breite	Dauer	
38924	50 mm	10 m	1
38964	50 mm	25 m	1

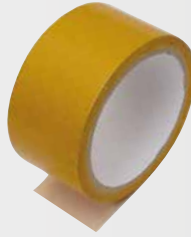

DOPPELSEITIGES KLEBEBAND, POLYPROPYLEN

PP
Polypropylen

Nr.	Breite	Dauer	
38929	50 mm	10 m	1
38966	50 mm	25 m	1



KLEBEBAND DOPPELSEITIGES MONTAGEBAND

MADE IN EU

Nr.	Breite	Dauer	
38990	19 mm	5 m	48
38991	25 mm	5 m	36



PROFESSIONELLES VERSTÄRKTES WASSERDICHTES BAND

MADE IN EU

Nr.	Breite	Dauer	
38995	48 mm	25 m	24



TEXTILBAND, WASSERDICHT

Nr.	Breite	Dauer	
38965	30 mm	10 m	1
38928	50 mm	10 m	72
38934	50 mm	45 m	24



blue dolphin tapes
DUCT TAPE-BAND, WASSERFEST

MADE IN EU

Nr.	Breite	Dauer	
37275	48 mm	50 m	24



blue dolphin tapes
FASSADENBAND FÜR PUTZ

UV STABLE **MADE IN EU**

Nr.	Breite	Dauer	
37271	38 mm	20 m	24
37270	48 mm	20 m	24
37272	48 mm	50 m	24



blue dolphin tapes
PE AUSSENSCHUTZBAND FÜR FENSTER
für die Dauer von 30 Tagen

UV STABLE **MADE IN EU**

Nr.	Breite	Dauer	
37273	48 mm	50 m	24



blue dolphin tapes
PROFESSIONELLES PAPIERABDECKBAND

MADE IN EU

Nr.	Breite	Dauer	
37263	38 mm	50 m	24
37264	48 mm	50 m	24

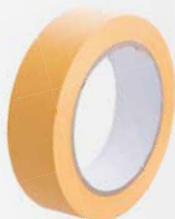

PVC-ABDECKBAND

MADE IN EU

Nr.	Breite	Dauer	
37266	30 mm	33 m	60
37267	38 mm	33 m	48
37268	50 mm	33 m	36



PAPIERABDECKBAND

MADE IN EU

Nr.	Breite	Dauer	
37255	19 mm	50 m	12
37256	25 mm	50 m	12
37257	30 mm	50 m	7
37258	38 mm	50 m	6
37259	50 mm	50 m	6



PVC-VERPACKUNGSBAND

MADE IN EU

Nr.	Breite	Dauer	
38942	50 mm	50 m	72



METALLISIERTES BAND



Nr.	Breite	Dauer	
38972	50 mm	50 m	1
38973	50 mm	100 m	1



SELBSTKLEBENDE ALUMINIUMFOLIE



Nr.	Breite	Dauer	
38963	48 mm	10 m	1
38943	48 mm	45 m	24



ANTI-RUTSCH-BAND

Nr.	Breite	Dauer	Stärke	
37280	25 mm	15 m	0,8 mm	72
37281	50 mm	15m	0,8 mm	36



SELBSTVULKANISIERENDES BAND

Nr.	Breite	Dauer	
38930	19 mm	5 m	100



SELBSTKLEBENDES GIPSKARTONBAND



Nr.	Breite	Dauer	
38935	50 mm	20 m	60
38937	50 mm	45 m	36
38939	50 mm	90 m	24
38940	50 mm	153 m	24



GLASFASERBAND



Nr.	Breite	Dauer	
38941	50 mm	25 m	40



TEFLONKLEMPNERBAND



Nr.	Breite	Dauer	Werkstoffdicke	
38969	19 mm	15 m	0,2 mm	10



TEFLONKLEMPNERBAND



Nr.	Breite	Dauer	Werkstoffdicke	
38933	12 mm	10 m	0,075 mm	10



TEFLON-FADEN

- zur Installation von Wasser und Gas



Nr.	Breite	Dauer	
38926	2 mm	150 m	20

FESTA

TEFLON-FADEN



· 160m
· -20°C ... +130°C
· max 16 bar



Nr.	Spezifikation	
38975		1



BANDABROLLER

Nr.	
38985	1



BINDUNGSBAND MIT KLETTVERSCHLUSS

Nr.	Spezifikation	
45471	12 mm x 5 m	1



FESTA

BAND MIT KLETTVERSCHLUSS 3 ST.



Nr.	Breite	Dauer	
37295	20 mm	150 mm	1
37296	20 mm	200 mm	1
37297	20 mm	250 mm	1

SPANN-SCHRAUBE

DIN 1480 Zn



Nr.	Spezifikation	
50100	5 x 70 mm	10
50101	6 x 90 mm	10
50102	8 x 125 mm	10
50103	10 x 150 mm	10

Nr.	Spezifikation	
50104	12 x 200 mm	10
50106	16 x 230 mm	10
50108	20 x 220 mm	10

KARABINER

DIN 5299 C Zn



Nr.	Spezifikation	
51204	4 mm	10
51205	5 mm	10
51206	6 mm	10
51207	7 mm	10
51208	8 mm	10

Nr.	Spezifikation	
51209	9 mm	10
51210	10 mm	10
51211	11 mm	10
51212	12 mm	10

ARTIKEL RAPID

Zn



Nr.	Spezifikation	
51241	4 mm	10
51242	5 mm	10
51243	6 mm	10
51244	7 mm	10

Nr.	Spezifikation	
51245	8 mm	10
51246	10 mm	10
51247	12 mm	10

MIT HAKEN

Zn



Nr.	Spezifikation	
51271	3 mm	10
51272	4 mm	10
51273	5 mm	10
51274	6 mm	10

Nr.	Spezifikation	
51275	7 mm	10
51276	8 mm	10
51278	10 mm	10

ÖSENMUTTER

DIN 5820 Zn



Nr.	Spezifikation	
51320	6 mm	10
51321	8 mm	10
51322	10 mm	10
51323	12 mm	10

Nr.	Spezifikation	
51324	14 mm	10
51325	16 mm	10
51327	20 mm	10

ÖSENSCHRAUBE

DIN 5820 Zn



Nr.	Spezifikation	
51300	6 mm	10
51301	8 mm	10
51302	10 mm	10
51303	12 mm	10
51304	14 mm	10

Nr.	Spezifikation	
51305	16 mm	10
51306	18 mm	10
51307	20 mm	10
51308	22 mm	10



DREHKARABINERHAKEN

Zn

Nr.	Spezifikation	
51220	53 mm	10
51221	67 mm	10
51222	76 mm	10



DREHBARE SEILKLEMME

Zn

Nr.	Spezifikation	
51225	3,8 mm	10
51226	4,5 mm	10
51227	6,0 mm	10



SEILKUPPLUNG

DIN 5685 C Zn

Nr.	Spezifikation	
51341	Ø 10 mm	10



SEILKLEMME

Zn

No.	specification	
51280	3 mm	10
51281	5 mm	10
51282	6 mm	10
51283	8 mm	10
51284	10 mm	10
51286	12 mm	10
51287	14 mm	10
51288	16 mm	10



SEILKAUSCHE

Zn

Nr.	Spezifikation	
51258	Ø 16 mm	10
51259	Ø 18 mm	10
51260	Ø 20 mm	10
51261	Ø 22 mm	10
51262	Ø 24 mm	10
51264	Ø 28 mm	10

KETTENHEBER

Nr.	Last	min. Höhe	Hub	Anzahl der Rollen	Kettenstärke	Gewicht	
26700	500 kg	280 mm	3 000 mm	1	6 mm	7,5 kg	1
26701	1 000 kg	300 mm	3 000 mm	1	6 mm	9 kg	1
26702	2 000 kg	380 mm	3 000 mm	2	6 mm	12 kg	1



SPANNUNGSEINRICHTUNG

Nr.	Spezifikation	
50035	2 t	6
50036	4 t	4



KETTE KURZE ÖSE

DIN 5685 A Zn



Nr.	Maschenweite	Dauer		Nr.	Maschenweite	Dauer	
51402	2 x 10 mm	110 m	1	51406	6 x 24 mm	18 m	1
51403	3 x 16 mm	60 m	1	51407	7 x 50 mm	16 m	1
51404	4 x 21 mm	40 m	1	51408	8 x 32 mm	10 m	1
51405	5 x 23 mm	30 m	1	51410	10 x 39 mm	10 m	1

KNOTENKETTE

DIN 5686 Zn



Nr.	Ø des Materials	Dauer		Nr.	Ø des Materials	Dauer	
51430	1,4 mm	150 m	1	51433	2,0 mm	118 m	1
51431	1,6 mm	150 m	1	51435	2,5 mm	70 m	1
51432	1,8 mm	130 m	1	51436	2,8 mm	50 m	1

KETTE LANGE ÖSE

DIN 5685 C Zn



Nr.	Maschenweite	Dauer		Nr.	Maschenweite	Dauer	
51412	2 x 12 mm	80 m	1	51416	6 x 43 mm	18 m	1
51413	3 x 26 mm	60 m	1	51417	7 x 50 mm	16 m	1
51414	4 x 32 mm	38 m	1	51418	8 x 54 mm	10 m	1
51415	5 x 35 mm	32 m	1	51420	10 x 65 mm	10 m	1

KUNSTSTOFFKETTE



Nr.	Spezifikation	
51450	6 mm 25 m rot-weiß	1

WINDE MIT SEIL UND HAKEN

Zn



Nr.	Tragfähigkeit	Seillänge,	
26720	300 kg	8 m	1
26705	450 kg	8 m	1
26721	500 kg	8 m	1
26722	800 kg	8 m	1
26706	900 kg	8 m	1
26707	1350 kg	8 m	1

VERKAUFSSTAND FÜR SEILE UND KETTEN

Nr.	Spezifikation	
51196	Verkaufsständer für Ketten, ausgestattet	10
51197	Verkaufsständer für Seile, ausgestattet	10
51198	Verkaufsständer für Ketten	10
51199	Verkaufsständer für Seile	10



VERZINKTES STAHLDRAHTSEIL

Zn



Nr.	Seildurchmesser	Dauer	
51100	Ø 1 mm	500 m	1
51102	Ø 1,5 mm	500 m	1
51103	Ø 2 mm	200 m	1
51104	Ø 3 mm	200 m	1
51105	Ø 4 mm	100 m	1
51106	Ø 5 mm	75 m	1
51107	Ø 6 mm	75 m	1
51130	Ø 8 mm	75 m	1
51131	Ø 10 mm	50 m	1
51132	Ø 12 mm	50 m	1

VERZINKTER STAHLDRAHT IN PVC-VERPACKUNG

Zn

Nr.	Seildurchmesser	Dauer	
51108	Ø 2/3 mm	200 m	1
51109	Ø 3/4 mm	100 m	1
51110	Ø 4/5 mm	75 m	1
51111	Ø 5/6 mm	50 m	1



SEIL AUS EDELSTAHLDRAHT

INOX

Nr.	Seildurchmesser	Dauer	
51120	Ø 1 mm	300 m	1
51121	Ø 1,2 mm	300 m	1
51122	Ø 1,5 mm	300 m	1
51123	Ø 2 mm	200 m	1
51124	Ø 3 mm	200 m	1
51125	Ø 4 mm	100 m	1
51126	Ø 5 mm	75 m	1
51127	Ø 6 mm	75 m	1



GEWINDESTANGE

DIN 975 **Zn**

4.8 Festigkeitsklasse

Nr.	Spezifikation	
55040	M 4 1 m	200
55050	M 5 1 m	150
55060	M 6 1 m	100
55080	M 8 1 m	50
55100	M 10 1 m	20
55120	M 12 1 m	20
55140	M 14 1 m	15
55160	M 16 1 m	15
55180	M 18 1 m	10
55200	M 20 1 m	10
55220	M 22 1 m	5
55240	M 24 1 m	5
55300	M 30 1 m	5



GEWINDESTANGE EDELSTAHL

DIN 976 **INOX** **4.8** Festigkeitsklasse

Nr.	Spezifikation	
55315	M 12 1 m	20
55316	M 14 1 m	15
55317	M 16 1 m	15
55318	M 18 1 m	10
55319	M 20 1 m	10



vor nach



GEWINDESTANGE

DIN 975 **4.8** Festigkeitsklasse

Nr.	Spezifikation	
55051	M 5 1 m	150
55181	M 18 1 m	10
55201	M 20 1 m	10
55221	M 22 1 m	5



FESTA KANTENREINIGER

Ø 3 - 19 mm

1/4"

Nr.	Spezifikation	
16321		5



MUTTERN

DIN 934 **Zn**

4.8 Festigkeitsklasse

Nr.	Spezifikation	
55350	M 4 100 St.	1
55351	M 5 100 St.	1
55352	M 6 100 St.	1
55353	M 8 100 St.	1
55354	M 10 100 St.	1
55355	M 12 100 St.	1
55356	M 14 100 St.	1
55357	M 16 100 St.	1
55358	M 18 100 St.	1
55359	M 20 10 St.	1
55360	M 22 10 St.	1
55361	M 24 10 St.	1
55362	M 30 10 St.	1



UNTERLAGE

DIN 440R **Zn**

Nr.	Spezifikation	
55331	M 5 100 St.	1
55332	M 6 100 St.	1
55333	M 8 100 St.	1
55334	M 10 100 St.	1
55335	M 12 100 St.	1
55336	M 14 100 St.	1
55337	M 16 100 St.	1
55339	M 20 10 St.	1
55340	M 22 10 St.	1
55341	M 24 10 St.	1
55342	M 30 10 St.	1



FESTA ORGANIZER-BOX



Nr.	Spezifikation	
55650	375 x 290 x 67 mm	1



HOLZSCHRAUBEN

2000x

Nr.	Spezifikation	
55640	2000 St.	1



St.	Packungsinhalt
350	3,0 x 16 mm
280	3,0 x 20 mm
220	3,0 x 25 mm
250	3,5 x 20 mm
240	3,5 x 25 mm
180	3,5 x 3, mm
280	4,0 x 16 mm
80	4,0 x 30 mm
40	4,0 x 40 mm
30	4,0 x 50 mm
25	5,0 x 50 mm
25	5,0 x 60 mm

HOLZSCHRAUBEN + DÜBEL, BOX

St.	Packungsinhalt
40	3,5 x 30 mm
25	4,0 x 40 mm
12	5,0 x 50 mm
8	6,0 x 60 mm

St.	Packungsinhalt
40	5 x 25 mm
25	6 x 30 mm
12	8 x 40 mm
8	10 x 50 mm

170x

Nr.	Spezifikation	
55645		1



HOLZSCHRAUBEN, BOX

St.	Packungsinhalt
60	3,0 x 12 mm
50	3,0 x 16 mm
40	3,0 x 20 mm
50	3,5 x 20 mm
40	3,5 x 30 mm
25	4,0 x 30 mm
20	4,0 x 40 mm
15	5,0 x 50 mm
10	5,0 x 60 mm

310x

Nr.	Spezifikation	
55642		1





SCHUTZBRILLE

CE EN 166

Nr.	Spezifikation	
50510		10



SCHUTZHÖRER

CE EN 352 27 dB

Nr.	Spezifikation	
50563		1



SCHUTZHÖRER

CE EN 352 27 dB

Nr.	Spezifikation	
50564		1



SCHUTZBRILLE

CE EN 166

Nr.	Spezifikation	
50514		10



SCHUTZSCHILD PE

CE EN 166

Nr.	Spezifikation	
50556		10



SCHUTZSCHILD MIT GITTER

CE EN 1731

Nr.	Spezifikation	
50562		10



SCHUTZBRILLE

· einstellbare Seitenlänge

CE EN 166

Nr.	Spezifikation	
50511		12



OHRSTÖPSEL

Nr.	Spezifikation	
50560		100



OHRSTÖPSEL MIT KORDEL

Nr.	Spezifikation	
50559		100



SCHUTZBRILLE

CE EN 170

Nr.	Spezifikation	
50512	dark	12



CLIMAX-SCHUTZHELM

CE EN 397 MADE IN EU

Nr.	Spezifikation	
50550	blau	30
50551	rot	30
50553	weiß	30
50554	gelb	30



WARNWESTE

CE EN 20471

Nr.	Spezifikation	
50570	orange	100
50571	gelb	100



SCHUTZBRILLE

CE EN 166

Nr.	Spezifikation	
50513		1



MOBILE KNEEBANK

Nr.	Spezifikation	
37135		1



FESTA
KNIESCHUTZ

Nr.	Spezifikation	
37145	gel	8



FESTA
KNIESCHUTZ

Nr.	Spezifikation	
37140	gel	12



FESTA
KNIESCHUTZ

Nr.	Spezifikation	
37144	gel	12



FESTA
KNIESCHUTZ

Nr.	Spezifikation	
37143		12



FESTA
KNIESCHUTZ

Nr.	Spezifikation	
37142	komfort	20



KNIESCHUTZ

Nr.	Spezifikation	
37139	neopren	10



KNIESCHUTZ

Nr.	Spezifikation	
37141		6





**LEDERHANDSCHUHE
VERSTÄRKT**

· Mit Futter in der Handinnenfläche



Nr.	Spezifikation	
50518	Größe 11"	12



**LEDERHANDSCHUHE
VERSTÄRKT**

· Mit Futter in der Handinnenfläche



Nr.	Spezifikation	
50519	Größe 10,5"	12



LEDERHANDSCHUHE



Nr.	Spezifikation	
50520	Größe 10,5"	12



**BAUMWOLLHANDSCHUHE
MIT PVC-NOPPEN**

Nr.	Spezifikation	
50524	Größe 10"	12



**BAUMWOLLHANDSCHUHE
IN PVC GETAUCHT**



Nr.	Spezifikation	
50525	Größe 10" - Länge 35 cm	12



**POLYESTER-HANDSCHUHE
MIT PVC-NOPPEN**

· Mit PVC-Scheiben

Nr.	Spezifikation	
50526	Größe 10"	12



**BAUMWOLLHANDSCHUHE
IN LATEX GETAUCHT**



Nr.	Spezifikation	
50522	Größe 10"	12



**NYLONHANDSCHUHE IN
NITRIL GETAUCHT**



Nr.	Spezifikation	
50533	Größe 10"	12



**NYLONHANDSCHUHE IN
LATEXSCHAUM GETAUCHT**

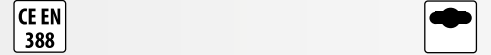

Nr.	Spezifikation	
50535	Größe 8"	12
50536	Größe 9"	12
50537	Größe 10"	12



**NYLONHANDSCHUHE IN
NITRILSCHAUM GETAUCHT**

· Mit PVC-Scheiben



Nr.	Spezifikation	
50539	Größe 10"	12



**ACRYL-WINTERHANDSCHUHE
IN LATEX GETAUCHT**

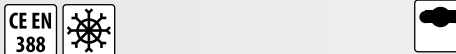

Nr.	Spezifikation	
50529	Größe 10"	12



GARTENHANDSCHUHE



Nr.	Spezifikation	
50557	Größe 7"	12
50558	Größe 8"	12
50549	Größe 9"	12



BAUMWOLL-HANDSCHUHE

Mit PVC-Scheiben

Nr.	Spezifikation	
50531	Größe 9"	12



MECHANIKERHANDSCHUHE
- ZIEGENLEDER



Nr.	Spezifikation	
50541	Größe 9"	12
50542	Größe 10"	12



MECHANIKERHANDSCHUHE,
NYLON - SCHWEINSLEDER



Nr.	Spezifikation	
50544	Größe 10"	12



NYLONHANDSCHUHE IN
POLYURETHAN GETAUCHT



Nr.	Spezifikation	
50527	Größe 10"	12



SCHWEISSHAND-
SCHUHE, LEDER



Nr.	Spezifikation	
50540	Größe 11"	12



EINWEG-
VINYLHANDSCHUHE

klar, ungepudert



Nr.	Spezifikation	
50532	Größe 9"	100



RESPIRATOR



Nr.	Spezifikation	
50500	FFP2 ohne Ventil	30



RESPIRATOR



Nr.	Spezifikation	
50503	FFP2 mit Ventil	20



SCHUTZANZUG
MIT KAPUZE

Nr.	Spezifikation	
50585	Größe M	1
50586	Größe L	1
50587	Größe XL	1
50588	Größe XXL	1



SCHWEISS-
SCHÜRZE



Nr.	Spezifikation	
50555	Haut	1



FESTO

WERKZEUGTASCHE MIT METALLGRIFF

Nr.	Höhe	Dauer	Tiefe	
37331	280 mm	490 mm	230 mm	2



FESTO

TASCHE

Nr.	Breite	Höhe	Tiefe	
37332	480 mm	290 mm	250 mm	1

FESTO

TASCHE

Nr.	Breite	Höhe	Tiefe	
37330	610 mm	400 mm	270 mm	5



FESTO

WERKZEUGKOFFER

· verstärkte Taschen

Nr.	Spezifikation	
37325		10



FESTO

WERKZEUGKOFFER

· verstärkte Taschen

Nr.	Spezifikation	
37326		12



FESTO

GÜRTEL MIT SCHNALLE

Nr.	Spezifikation	
37328	145 cm	20



FESTA

MONTAGEGÜRTEL SET

· 14 Taschen + Öse

Nr.	Dauer	Breite	
37311	120 cm	6 cm	1



FESTA

NYLONGÜRTEL

Nr.	Dauer	Breite	
37310	120 cm	6 cm	1



FESTA

WERKZEUGKOFFER

· 8 Taschen

Nr.	Breite	Höhe	
37320	300 mm	250 mm	1



FESTA

WERKZEUGKOFFER

· 4 Taschen

Nr.	Breite	Höhe	
37321	350 mm	300 mm	1



FESTA

ARBEITSWESTE

Nr.	Spezifikation	
37350		20



FESTA

WERKZEUGGÜRTEL, LEDER



Nr.	Spezifikation	
37302	6 Taschen	50
37303	11 Taschen	25



WERKZEUGGÜRTEL, LEDER



Nr.	Spezifikation	
37300	6 Taschen	50
37301	11 Taschen	25



FESTA



PROFESSIONELLE LEDERTASCHE



Nr.	Höhe	Dauer	Tiefe	
37342	270 mm	430 mm	180 mm	1



ELEKTRIKERTASCHE, LEDER



Nr.	Höhe	Dauer	Tiefe	
37341	260 mm	430 mm	200 mm	1



LEDERTASCHE MIT VERSTÄRKTEM BODEN



Nr.	Höhe	Dauer	Tiefe	
37340	240 mm	430 mm	150 mm	1



HANDWERKERTASCHE MIT RIEMEN

Nr.	Höhe	Dauer	Tiefe	
37344	250 mm	300 mm	130 mm	1



TASCHE MIT VERSTÄRKTEM BODEN

Nr.	Höhe	Dauer	Tiefe	
37343	240 mm	430 mm	150 mm	1



ELEKTRIKERTASCHE

Nr.	Höhe	Dauer	Tiefe	
37345	270 mm	430 mm	180 mm	1

SCHNALLE - LEDER "O"



Nr.	Spezifikation
37308	20



SCHNALLE - LEDER "U"



Nr.	Spezifikation
37309	20





FESTA

TÜRSCHLOSSZYLINDER,
MESSING



Nr.	Spezifikation	
23001	65 mm · 175 g	10



TÜRSCHLOSSZYLINDER,
VERMESSINGT



Nr.	Spezifikation	
23000	65 mm · 75 g	15



FESTA

VORHÄNGESCHLOSS



Nr.	Spezifikation	
23261	25 mm	6
23262	32 mm	12
23263	38 mm	6
23264	45 mm	6
23265	52 mm	12
23266	63 mm	6



FESTA

VERSTÄRKTES
MESSINGSCHLOSS



Nr.	Spezifikation	
23125	25 mm	12
23130	30 mm	12
23135	35 mm	12
23140	40 mm	12
23150	50 mm	12
23160	60 mm	12



FESTA

VORHÄNGESCHLOSS
AUS MESSING,
KUNSTSTOFFBESCHICHTET



Nr.	Spezifikation	
23310	30 mm	10
23311	40 mm	10
23312	50 mm	6



FESTA

VORHÄNGESCHLOSS
VERLÄNGERT



Nr.	Spezifikation	
23211	25 mm	12
23212	32 mm	12
23213	38 mm	6
23214	45 mm	6
23215	52 mm	6



FESTA

VORHÄNGESCHLOSS



Nr.	Spezifikation	
23274	60 mm	6
23275	70 mm	12

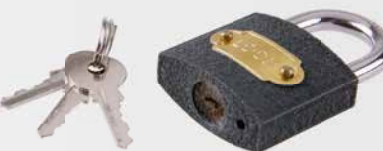

VORHÄNGESCHLOSS



Nr.	Spezifikation	
23220	25 mm	6
23225	30 mm	6
23232	32 mm	6
23240	40 mm	6
23250	50 mm	6
23260	60 mm	6



SCHLOSS VERMESSINGT



Nr.	Spezifikation	
23020	20 mm	12
23025	25 mm	12
23030	30 mm	12
23035	35 mm	12
23040	40 mm	12
23050	50 mm	12
23060	60 mm	12





VORHÄNGSCHLOSS

SCHLOSS VERMESSINGT, VERLÄNGERT



Nr.	Spezifikation	
23070	40 mm	12



Nr.	Spezifikation	
23010	50 mm	6



VORHÄNGSCHLOSS



Nr.	Spezifikation	
23005	40 mm	6
23006	50 mm	6



FESTA

FAHRRADSCHLOSS MIT NUMERISCHEM CODE



Nr.	Spezifikation	
23288	120 cm x Ø 10 mm	1



FESTA

FAHRRADSCHLOSS MIT NUMERISCHEM CODE



Nr.	Spezifikation	
23287	65 cm x Ø 10 mm	1



FESTA

FAHRRADSCHLOSS MIT GRIF



Nr.	Spezifikation	
23290	120 cm x Ø 8 mm	1
23291	150 cm x Ø 8 mm	1
23292	180 cm x Ø 8 mm	1

FAHRRADSCHLOSS



Nr.	Spezifikation	
23282	55 cm x Ø 8 mm	50
23284	65 cm x Ø 8 mm	50



VORHÄNGSCHLOSS MIT NUMERISCHEM CODE



Nr.	Spezifikation	
23281		20





FESTA

SICHERHEITSFACH MIT ELEKTRONISCHEM SCHLOSS



- Schlossart: elektronisch, mechanisch
- Sicherheitsschlüssel:
- Abmessungen 350x250x250mm
- Gewicht 10 kg



Nr.	Spezifikation	
23270		1

FESTA

SCHLÜSSELANHÄNGER



- verstärkter Ring



Nr.		
23391		50

SCHLÜSSELANHÄNGER



Nr.		
23390		1



GELDSCHRANK



Nr.	Breite	Tiefe	Höhe	
70120	125 mm	95 mm	60 mm	1



TÜRKLAMMER

Nr.	Spezifikation	
51514	100 mm	25
51515	120 mm	25
51516	140 mm	25
51517	160 mm	25



STECKER

Nr.	Spezifikation	
51510	100 mm	12
51511	120 mm	12
51512	140 mm	12
51513	160 mm	12



SCHLÜSSELSCHRANK



Nr.	Spezifikation	
70140	250 x 180 x 80 mm - für 48 Schlüssel	12
70141	300 x 230 x 90 mm - für 90 Schlüssel	8

GELDSCHRANK



Nr.	Breite	Tiefe	Höhe	
70121	152 mm	118 mm	80 mm	36



GELDSCHRANK



Nr.	Breite	Tiefe	Höhe	
70122	200 mm	160 mm	90 mm	20



GELDSCHRANK



Nr.	Breite	Tiefe	Höhe	
70123	250 mm	180 mm	90 mm	16





GELDSCHRANK



Nr.	Breite	Tiefe	Höhe	
70124	300 mm	240 mm	90 mm	10



GELDSCHRANK



Nr.	Breite	Tiefe	Höhe	
70125	370 mm	280 mm	90 mm	8



BRIEFKASTEN



Nr.	Farbe	Breite	Höhe	Tiefe	
70101	weiß	290 mm	360 mm	105 mm	5
70100	braun	290 mm	360 mm	105 mm	5



BRIEFKASTEN



Nr.	Farbe	Breite	Höhe	Tiefe	
70102	weiß	310 mm	260 mm	90 mm	10
70103	braun	310 mm	260 mm	90 mm	10



BRIEFKASTEN



Nr.	Farbe	Breite	Höhe	Tiefe	
70105	braun	310 mm	360 mm	90 mm	5



BRIEFKASTEN



Nr.	Farbe	Breite	Tiefe	Höhe	
70108	weiß	370 mm	134 mm	364 mm	5



BRIEFKASTEN



Nr.	Material	Breite	Tiefe	Höhe	
70107	Edelstahl	360 mm	100 mm	520 mm	6



BRIEFKASTEN



Nr.	Material	Breite	Tiefe	Höhe	
70106	Edelstahl	360 mm	100 mm	360 mm	5



BRIEFKASTEN



Nr.	Material	Breite	Tiefe	Höhe	
70109	Edelstahl	310 mm	90 mm	260 mm	6



BRIEFKASTEN



Nr.	Material	Breite	Tiefe	Höhe	
70110	Edelstahl	310 mm	90 mm	360 mm	6

ANALOGER MÜNZZÄHLER

Nr.	maximale Tragfähigkeit		
24260	50 kg	10	



MÜNZZÄHLER

Nr.	maximale Tragfähigkeit	
24212	12,5 kg	12
24225	25 kg	6
24250	50 kg	6
24255	100 kg	6
24258	150 kg	6



PINZETTE MIT LED-LICHT

Nr.	Spezifikation	
50005	95 mm	8



PINZETTENSET AUS EDELSTAHL

Nr.	Spezifikation	
50004		1

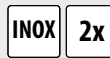

MAUSEFALLE

Nr.	Spezifikation	
70221	90 x 45 mm aus Holz	1



MAUSEFALLE

Nr.	Spezifikation	
70220	97 x 47 mm aus Kunststoff	48



ABFLUSSREINIGER

kann mit Bohrer verwendet werden

Nr.	Dauer	Ø	
50014	6 m	6 mm	6

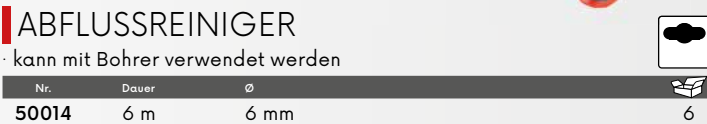

ABFLUSSREINIGER

Nr.	Dauer	
50010	3 m	10
50011	5 m	5
50012	10 m	3
50013	15 m	4



ABFLUSSREINIGER

Nr.	Dauer	Ø	
50009	3 m	5 mm	40



PUMPE ZUR REINIGUNG VON ABFLUSSROHREN

Nr.	Dauer	Ø	
50015	385 mm	65 mm	30



KABELEINZIEHSYSTEM

Nr.	Dauer	Ø	
51181	8 m	5 mm	25
51182	10 m	5 mm	25





244

GLÄTTER, KELLEN,
SPACHTEL

250

SCHAUFELN FÜR
MAUERWERK

254

SCHABER UND
SCHLEIFGLÄTTER

255

GLÄTTER UND
SCHLEIFGITTER

257

GLÄTTER FÜR
PUTZARBEITEN

261

RÜHRER



266

BAURÜHRER



269

BAUSCHUTTDEPONIE



269

SCHUBKARREN



270

HORIZONT LATTEN



272

PFLASTERBRECHER UND
BORDSTEINTRÄGER

274

PFLASTERFRÄSER



277

HILFSMITTEL FÜR
PFLASTERARBEITEN

280

NIVELLIERUNG



286

STYROPORSCHNEIDE-
MASCHINE

292

TROCKENBAUWERKZEUGE



294

PB-BRENNER UND
DRUCKMINDERER

296

MAURERGEFÄSSE



297

AUSPRESSPISTOLE



299

PISTOLE FÜR PU-SCHAUM



300

MALERBEDARF



305

PE-PLANE



306

LEITERN



307

SCHORNSTEINTÜREN UND
SCHALUNGSSTÄNDER

BAUGERÄTE

242 - 307





FESTA

FESTA

EDELSTAHL-
GLÄTTER
280 X 130 MM

· Gummihandgriff



Nr.	Spezifikation	
31140	gerade	10

FESTA

EDELSTAHL-
GLÄTTER
280 X 130 MM

· Gummihandgriff



Nr.	Spezifikation	
31148	gerade mit runden Ecken	10

FESTA

EDELSTAHL-
ZAHNGLÄTTER
280 X 130 MM

· Gummihandgriff



Nr.	Spezifikation	
31146	Ø 16	10

FESTA

EDELSTAHL-
ZAHNGLÄTTER
280 X 130 MM

· Gummihandgriff



Nr.	Spezifikation		Nr.	Spezifikation	
31141	e 4	10	31144	e 10	10
31142	e 6	10	31145	e 12	10
31143	e 8	10			

FESTA

EDELSTAHL-
ZAHNGLÄTTER
280 X 130 MM



Nr.	Spezifikation		Nr.	Spezifikation	
31101	e 4	10	31131	e 10	10
31111	e 6	10	31132	e 12	10
31121	e 8	10			

FESTA

EDELSTAHL-
GLÄTTER
280 X 130 MM



Nr.	Spezifikation	
31091	gerade	10

FESTA

EDELSTAHL-
GLÄTTER
280 X 130 MM



Nr.	Spezifikation	
31011	gerade	10

FESTA

EDELSTAHL-
ZAHNGLÄTTER
280 X 130 MM



Nr.	Spezifikation		Nr.	Spezifikation	
31021	e 4	10	31051	e 10	10
31031	e 6	10	31053	e 12	10
31041	e 8	10			

EDELSTAHL-
GLÄTTER
270 X 125 MM



Nr.	Spezifikation	
31005	gerade	25

EDELSTAHL-
ZAHNGLÄTTER
270 X 125 MM



Nr.	Spezifikation		Nr.	Spezifikation	
31006	e 4	24	31008	e 8	24
31007	e 6	24	31009	e 10	24

FESTA

EDELSTAHL-
GLÄTTER
360 X 130 MM



Nr.	Spezifikation	
31151	gerade	10

FESTA

EDELSTAHL-
GLÄTTER
360 X 130 MM



Nr.	Spezifikation	
31150	gerade	10

FESTA

EDELSTAHL-
GLÄTTER
480 X 130 MM



Nr.	Spezifikation	
31082	gerade	10

FESTA

EDELSTAHL-
GLÄTTER
680 X 130 MM



Nr.	Spezifikation	
31155	gerade	10

FESTA

EDELSTAHL-
ZAHNGLÄTTER
500 X 130 MM



Nr.	Spezifikation	
31052	e 4	10
31061	e 6	10
31062	e 8	10
31071	e 10	10
31072	e 12	10

FESTA

EDELSTAHL-
GLÄTTER
500 X 130 MM



Nr.	Spezifikation	
31081	gerade	10



FESTA

EDELSTAHL-LÖFFEL

INOX · Gummihandgriff

Nr.	Spezifikation	
31232	120 mm	10
31233	140 mm	10

**FESTA**

EDELSTAHL-LÖFFEL

INOX

Nr.	Spezifikation	
31220	120 x 80 mm	10
31221	140 x 80 mm	10

**FESTA**EDELSTAHL-LÖFFEL
RUND

INOX · Gummihandgriff

Nr.	Spezifikation	
31334	160 x 100 mm	10

**FESTA**EDELSTAHL-LÖFFEL
RUND

INOX

Nr.	Spezifikation	
31343	160 x 100 mm	10

**FESTA**EDELSTAHL-
SCHMIERLÖFFEL

INOX · Gummihandgriff

Nr.	Spezifikation	
31360	40 mm	10
31380	60 mm	10
31390	80 mm	10

**FESTA**EDELSTAHL-
SCHMIERLÖFFEL

INOX

Nr.	Spezifikation	
31362	40 mm	10
31382	60 mm	10

**FESTA**EDELSTAHL-LÖFFEL
KATZENZUNGE

INOX · Gummihandgriff

Nr.	Spezifikation	
31330	140 x 50 mm	10
31340	160 x 60 mm	10

**FESTA**EDELSTAHL-LÖFFEL
KATZENZUNGE

INOX

Nr.	Spezifikation	
31332	140 x 50 mm	10
31341	160 x 60 mm	10

**FESTA**EDELSTAHL-
WINKELÖFFEL

INOX · Gummihandgriff

Nr.	Spezifikation	
31280	80 x 60 x 60 mm	10

**FESTA**EDELSTAHL-
WINKELÖFFEL

INOX

Nr.	Spezifikation	
31281	80 x 60 x 60 mm	10

**FESTA**

EDELSTAHL-ECKLÖFFEL

INOX · Gummihandgriff

Nr.	Spezifikation	
31270	80 x 60 x 60 mm	10

**FESTA**

EDELSTAHL-ECKLÖFFEL

INOX

Nr.	Spezifikation	
31271	80 x 60 x 60 mm	10



FESTA

EDELSTAHL-DACHDECKERLÖFFEL

INOX · Gummihandgriff

Nr.	Spezifikation	
31320	140 x 75 mm	10



FESTA

EDELSTAHL-DACHDECKERLÖFFEL

INOX

Nr.	Spezifikation	
31322	140 x 75 mm	10



FESTA

EDELSTAHL-ZAHNLÖFFEL MIT RAND

INOX

Nr.	Spezifikation	
31218	180 mm e 6	12



FESTA

EDELSTAHL-SPACHTEL

· Gummihandgriff

INOX

Nr.	Spezifikation	
31510	40 mm	10
31511	60 mm	10
31512	80 mm	10



FESTA

EDELSTAHSCHABER

· Verstärkter Griff

INOX

Nr.	Spezifikation	
32173	75 mm	10



FESTA

SCHABER AUS ROSTFREIEM STAHL MIT HÜLSE

· Gummihandgriff
· passender Stiel 52010

INOX

Nr.	Spezifikation	
32170	100 mm	12



FESTA

EDELSTAHLSPACHTEL MIT BIT

· Gummihandgriff

INOX

Nr.	Spezifikation	
31455	150 mm	12
31456	200 mm	12

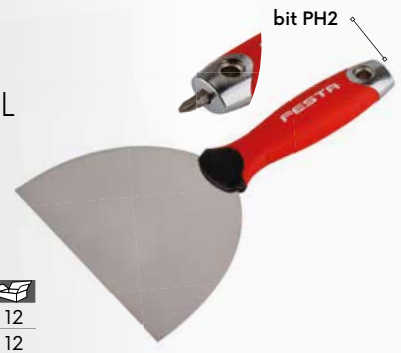

FESTA

ECKENSPACHTEL

INOX

Nr.	Spezifikation	
31517		10



FESTA

RAKEL AUS ROSTFREIEM STAHL MIT VERSTÄRKUNG

· Gummihandgriff

INOX

Nr.	Spezifikation	
31505	200 mm	5
31506	250 mm	5
31507	300 mm	5



**FESTA****SCHABER FÜR WAND UND BODEN**

· verstärkte Klinge

INOX

Nr.	Breite	Dauer	
32174	100 mm	500 mm	1

FESTA**EDELSTAHL-SPACHEL****INOX**

R.s.	leirás	
31461	40 mm	12
31471	60 mm	12
31481	80 mm	12
31491	100 mm	12
31467	120 mm	12
31468	140 mm	12

**FESTA****EDELSTAHL-SPACHEL****INOX**

Nr.	Spezifikation	
31498	150 mm	12
31499	200 mm	12
31500	100 mm	12

**EDELSTAHL-SPACHEL****INOX****MADE IN EU**

Nr.	Spezifikation	
31493	40 mm	20
31494	60 mm	20
31495	80 mm	20
31496	100 mm	20

**STAHLSPACHEL**

R.s.	leirás	
32176	30 mm	12
32186	40 mm	12
32196	50 mm	12
32206	60 mm	12
32216	80 mm	12
32226	100 mm	12
32234	125 mm	12

**STAHLSPACHEL SET****3x**

Nr.	Spezifikation	
32240	30, 50, 80 mm	10

**FESTA****STAHLSPACHEL**

Nr.	Spezifikation		Nr.	Spezifikation	
32161	30 mm	10	32171	90 mm	10
32162	40 mm	10	32166	100 mm	10
32163	50 mm	10	32172	110 mm	10
32164	60 mm	10	32167	120 mm	10
32169	70 mm	10	32168	140 mm	10
32165	80 mm	10			

**ROLLE ZUM AUFTRAGEN VON PUTZ**

- halter 180 mm - 52630
- halter 250 mm - 52625
- Stiel 52010, 52011, 52012, 52020, 52030



Nr.	Spezifikation				
52611	250 mm	Ø 8 mm	Ø 48 mm	50	
52612	180 mm	Ø 8 mm	Ø 48 mm	10	

FESTA

EDELSTAHLSPACHTEL
FÜR VOLLFLÄCHIGES
SPACHTELN

INOX

R.s.	leírás	
31555	35 cm	1
31556	45 cm	1
31557	60 cm	1
31558	80 cm	1
31559	100 cm	1



FESTA

SPACHTELHALTER
ZUR VOLLFLÄCHIGEN
VERSIEGELUNG

· für 31555 - 31559
· Stiel 52010, 52011, 52012, 52020, 52030

Č.p.	Specifikace	
31610		1



FESTA

TELESKOPSTANGE

· Faden für 31610, 34203

Č.p.	Specifikace	
52011	88 - 140 cm	1



SPACHTEL
AUS EDELSTAHL
MIT VERSTÄRKUNG

INOX

MADE IN EU

Nr.	Spezifikation	
31520	400 mm	1
31521	500 mm	
31522	600 mm	



Stiel 61254



31523



31524

ZUBEHÖR ZUR SPACHTEL
MIT VERSTÄRKUNG

MADE IN EU

Nr.	Spezifikation	
31523	ALU-Halter	1
31524	Halter Kunststoff	1

EDELSTAHL-
FASSADENKELLE

INOX

Nr.	Spezifikation	
31552	400 mm	10
31553	600 mm	10



RAKEL AUS
ROSTFREIEM
STAHL

INOX

MADE IN EU

Nr.	Spezifikation	
31541	250 mm	1
31551	250 mm schmal	1



STAHLGLÄTTER

Nr.	Spezifikation	
32062	280 x 160 mm	10
32060	500 x 140 mm	5

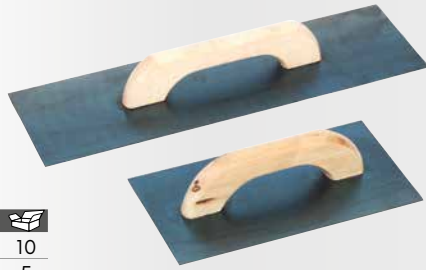
SPITZ-GLÄTTER,
STAHL

Nr.	Spezifikation	
32064	500 x 90 mm	5
32066	550 x 140 mm	5

KELLE STAHL
GESCHLIFFEN

Nr.	Spezifikation	
32015	160 x 130 mm	10
32014	180 x 130 mm	10
32016	200 x 140 mm	10



STAHLKELLE

Nr.	Spezifikation	
32001	160 x 110 mm	10
32002	160 x 130 mm	10
32003	180 x 130 mm	10
32013	200 x 140 mm	10

RUNDKELLE,
STAHL

Nr.	Spezifikation	
32018	160 x 110 mm	10

WISCHKELLE,
STAHL

Nr.	Spezifikation	
32024	140 x 80 mm	12

KATZENZUNGENKELLE,
STAHL

Nr.	Spezifikation	
32020	140 x 65 mm	12
32021	140 x 40 mm	12

DACHDECKERKELLE,
STAHL

Nr.	Spezifikation	
32026	140 x 85 mm	12



FESTA

KELLE MIT
EDELSTAHL-
GRIFF

INOX	Č.p.	specifikace	
	32285	Ø 180 mm	1



FESTA

KELLE
MIT GRIFF
VERZINKT

Zn	Č.p.	specifikace	
	32265	Ø 180 mm	10





FESTA

KELLE
MIT GRIFF

Č.p.	specifikace	
32273	Ø 160 mm	10
32283	Ø 180 mm	10
32293	Ø 215 mm	10

KUNSTSTOFF-
KELLE

	Č.p.	specifikace	
	32270	Ø 160 mm	1



STAHLKELLE

passender Stiel 61215

Č.p.	specifikace	
32302	Ø 180 mm	1
32313	Ø 215 mm	1
32301	Ø 235 mm	1



STAHLKELLE MIT GRIFF FÜR SCHAUFELSTIEL

passender Stiel 61200, 61201

Č.p.	specifikace	
32268	Ø 215 mm	1
32269	Ø 235 mm	1
32296	Ø 215 mm	1



BETONRECHEN

Č.p.	specifikace	
60100	hráblo na beton 295 x 150 mm	24
61169	hráblo s násadou 160 cm	3
61218	Stiel 160 cm	5



STAHLKELLE MIT STIEL

Č.p.	specifikace	
32295	Ø 180 mm délka násady 160 cm	3
32297	Ø 215 mm délka násady 160 cm	3
32298	Ø 235 mm délka násady 160 cm	3



NUTENSTANZMASCHINE FÜR YTONG

Nr.	Spezifikation	
32037	600 mm	1



YTONG SÄGEWINKEL

Nr.	Spezifikation	
32038	270 x 270 x 270 mm	1



YTONG PLANKELLE

Nr.	Spezifikation	
32089	150 mm	1



FESTA
FLACHMEISSEL

CrV	Nr.	Spezifikation	Breite der Spitze	
	19406	300 mm	25 mm	5
19407	400 mm	30 mm	5	



FESTA
SPITZMEISSEL

CrV	Nr.	Spezifikation	
	19408	250 mm	5
19409	350 mm	5	



FESTA
FLACHMEISSEL

CrV	Nr.	Spezifikation	Breite der Spitze	
	19460	300 mm	25 mm	5
19470	400 mm	30 mm	5	



SPITZMEISSEL

Nr.	Spezifikation	
19400	250 mm	5
19403	350 mm	6



FLACHMEISSEL

Nr.	Spezifikation	Breite der Spitze	
19401	250 mm	19 mm	6
19404	350 mm	22 mm	6



FLACHMEISSEL

Nr.	Spezifikation	Breite der Spitze	
19402	250 mm	50 mm	2
19405	350 mm	50 mm	6



NEW



FESTA

MALERSPACHTEL
AUS EDELSTAHL

INOX

Nr.	Spezifikation
31519	75 mm

MALERSPACHTEL
AUS EDELSTAHL

INOX

Nr.	Spezifikation
31497	63 x 195 mm



FESTA

TAPEZIERMESSER
AUS EDELSTAHL

INOX

Nr.	Spezifikation
31503	150 mm



MALERSCHABER

MADE IN EU

Nr.	Spezifikation
31501	100 mm
31502	Ersatzklinge

SPACHTEL FÜR
GIPSKARTONMACHER

PLASTIC

Nr.	Spezifikation
34308	50 mm
34307	80 mm
34306	100 mm
34305	150 mm



GLÄTTER FÜR SCHLEIFGITTER

Nr.	Spezifikation
34301	230 x 105 mm
34304	235 x 80 mm



FESTA

GLÄTTER FÜR SCHLEIFGITTER

Nr.	Spezifikation
34200	210 x 115 mm
34201	240 x 105 mm
34202	240 x 80 mm

STIELKELLE
FÜR SCHLEIFGITTER

Stiel 52030

ALU

Nr.	Spezifikation
34203	230 x 80 mm Aluminium
52030	Teleskopstiel

SCHLEIFGITTER
SET

10x

Nr.	Spezifikation
34271	115 x 290 mm Korngr. 120
34272	115 x 290 mm Korngr. 100
34273	115 x 290 mm Korngr. 80
34274	93 x 290 mm Korngr. 120
34275	93 x 290 mm Korngr. 100
34276	93 x 290 mm Korngr. 80

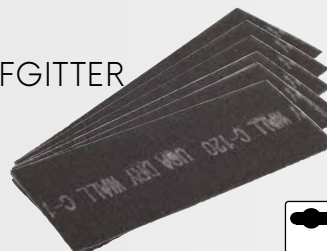
SCHLEIFGITTER
SET

3x

Nr.	Spezifikation
34280	115 x 290 mm Korngr. 120
34281	115 x 290 mm Korngr. 100
34282	115 x 290 mm Korngr. 80
34283	93 x 290 mm Korngr. 120
34284	93 x 290 mm Korngr. 100
34285	93 x 290 mm Korngr. 80



FESTA

JAPANISCHE SPACHTEL

4x

Nr.	Spezifikation	
31452	Edelstahl 50, 80, 100, 120 mm	10
31453	Stahl 50, 80, 100, 120 mm	10

FESTA

JAPANISCHE SPACHTEL, KUNSTSTOFF

4x

Nr.	Spezifikation	
31454	50, 80, 100, 120 mm	12

STAHLSPACHTEL

Nr.	Spezifikation	
31601	180 mm - gerade	1
31602	180mm A1	1
31603	180mm A2	1
31641	180 mm - e4	1



STAHLSPACHTEL

Nr.	Spezifikation	
31651	250 mm - gerade	1
31655	250 mm - e4	1

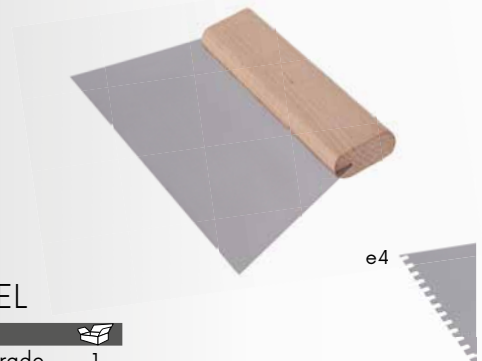

KUNSTSTOFF
ZAHNSPACHTEL

Nr.	Spezifikation	
37101	125 x 85 mm	100
37111	170 x 115 mm	100



KUNSTSTOFF-
SPACHTEL

Nr.	Spezifikation	
37051	gerade	1
37031	Zahn - 4 x 6 mm	1
37041	Zahn - 6 x 6 mm	1



MODELLIERKELLE,
STAHL

Nr.	Spezifikation	
32022	140 x 80 mm	12
32023	125 x 40 mm	12



EINSEITIGE
FUGENKELLE

Nr.	Spezifikation	
32040	10 mm	20
32041	12 mm	20
32042	15 mm	20
32043	18 mm	20
32044	20 mm	20



DOPPELSEITIGE
FUGENKELLE

Nr.	Spezifikation	
32050	10 12 mm	50
32051	10 15 mm	50
32052	10 18 mm	50
32053	15 20 mm	50



FESTASCHABER
FÜR YTONG

Pappel

MOQ
2Nr. Spezifikation
32317 450 x 95 mm

2

FESTAYTONG
SCHABER
FEIN GEZAHNT

Pappel

MOQ
2Nr. Spezifikation
32312 450 x 95 mm

2

FESTASCHABER
FÜR YTONG

Pappel

MOQ
2Nr. Spezifikation
32337 260 x 95 mm

2

FESTAYTONG
SCHABER
FEIN GEZAHNT

Pappel

MOQ
2Nr. Spezifikation
32338 260 x 95 mm

2

**FESTA**SPACHEL
FÜR BRISOLIT

Pappel

MOQ
2Nr. Spezifikation
32327 230 x 145 mm

2

SCHABER
FÜR YTONGMADE IN
EUČ.p. Spezifikace
32332 450 x 95 mmMOQ
2

2

SPACHEL
FÜR BRISOLITMADE IN
EUČ.p. Spezifikace
32333 230 x 145 mmMOQ
2

2

**FESTA**SCHABER
FÜR ALTEN
PUTZMADE IN
EUNr. Spezifikation
32314 400 x 180 mmMOQ
2

2

**FESTA**SCHABER
FÜR ALTEN
PUTZMADE IN
EUNr. Spezifikation
32329 270 x 130 mmMOQ
2

2

SCHABER FÜR
ALTEN PUTZ
MIT LÖCHERNMADE IN
EUNr. Spezifikation
33168 380 x 160 mmMOQ
2

2

**FESTA**SCHABER
FÜR ALTEN
PUTZNr. Spezifikation
32320 400 x 180 mmMOQ
2

2



SCHABER
FÜR ALTEN
PUTZ



MOQ 2

Nr.	Spezifikation	MOQ
32311	400 x 180 mm	2

FESTA

KUNSTSTOFF-
POLYSTYROL-
SCHLEIFSPACHTEL



MOQ 2

Nr.	Spezifikation	MOQ
32324	270 x 130 mm Korngr. 16	2
32323	270 x 130 mm Korngr. 16 Schleifpapier	10

STEINWOLLSCHABER

Zn

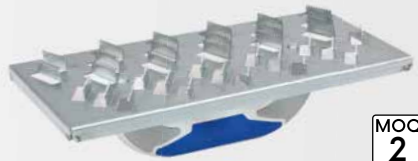

MOQ 2

Nr.	Spezifikation	MOQ
32328	285 x 145 mm	10

GITTERSCHABER

ALU

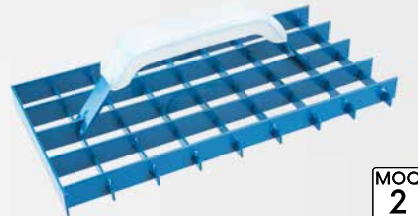
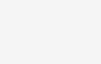

MOQ 2

Nr.	Spezifikation	MOQ
32316	280 x 150 mm	20

SCHABER

· 8 Klingen

ALU

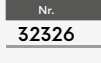

MOQ 2

Nr.	Spezifikation	MOQ
32326	450 x 90 mm	20

FESTA

KUNSTSTOFF-
GLÄTTER



MOQ 2

Nr.	Spezifikation	MOQ
34027	400 x 180 mm	20

FESTA

POLYSTYROL-
SCHLEIFGLÄTKELLE



Nr.	Spezifikation	MOQ
32318	400 x 180 mm	2
32319	500 x 250 mm	2
32321	400 x 180 mm Korngr. 16 Schleifpapier	10
32322	500 x 250 mm Korngr. 16 Schleifpapier	10

FESTA

GLÄTTEKELLE MIT
GEBUNDENEM
SCHLEIFMITTEL



MOQ 2

Nr.	Spezifikation	MOQ
32330	400 x 180 mm	2
32331	270 x 130 mm	2

FESTA

SCHABER



MOQ 2

Nr.	Spezifikation	MOQ
32325	225 x 105 mm	2

GITTERSCHABER,
GEZAHNT

ALU

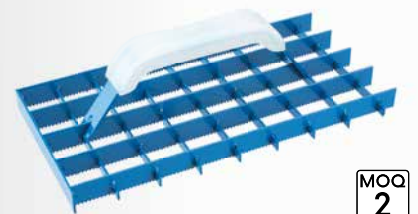

MOQ 2

Nr.	Spezifikation	MOQ
32335	290 x 145 mm	2

KUNSTSTOFF-
SCHABER

· 6 Klingen

Nr.	Spezifikation	MOQ
32315	270 x 90 mm	30

KUNSTSTOFF-
GLÄTTER



MOQ 2

Nr.	Spezifikation	MOQ
34028	400 x 180 mm	20

FESTA

ABS-GLÄTTER



MADE IN EU

Nr.	Spezifikation	
34041	280 x 140 - 2 mm	10
34051	280 x 140 - 3 mm	10
34053	280 x 140 - 3 mm gezahnt - e6	10

FESTA

KUNSTSTOFF-GLÄTTER OHNE OBERFLÄCHE



Č.p.	specifikace	
30003	270 x 125 mm	28
30004	235 x 115 mm	35
30005	210 x 115 mm	38
30007	210 x 60 mm	44

FESTA

HOLZGLÄTTER

Lindenholz



Nr.	Spezifikation	
34005	400 x 145 mm	40
34007	290 x 145 mm	20

HOLZGLÄTTER

Pappelholz



Nr.	Spezifikation	
34006	400 x 145 mm	40

POLYURETHAN-GLÄTTKELLE

MADE IN EU

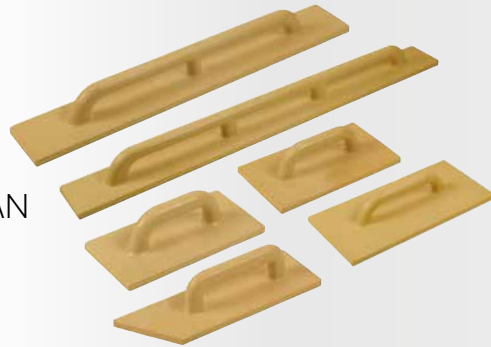

Nr.	Spezifikation		Nr.	Spezifikation	
34122	120 x 240 mm	50	34154	220 x 420 mm	15
34132	140 x 280 mm	40	34155	240 x 480 mm	15
34142	180 x 320 mm	25	34156	280 x 500 mm	10
34152	200 x 360 mm	20	34157	330 x 330 mm	5
34121	80 x 260 mm abgeschrägt	50	34158	120 x 800 mm	5
34153	100 x 400 mm	30	34159	120 x 1000 mm	5
			34160	120 x 1200 mm	5

POLYSTYROL-KELLE

MADE IN EU

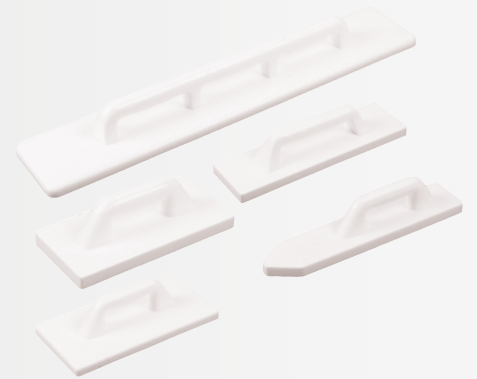

Nr.	Spezifikation	
34101	80 x 350 mm abgeschrägt	10
34061	130 x 270 mm	10
34111	170 x 320 mm	10
34071	130 x 450 mm	10
34081	140 x 750 mm	10
34091	140 x 900 mm	5

POLYURETHAN-SPACHTEL PUR



Nr.	Spezifikation	
34115	140 x 280 mm	36
34116	180 x 320 mm	36
34117	200 x 360 mm	24

GLÄTTUNGSPLATTE FÜR BETON

MADE IN EU



Nr.	Spezifikation	
15889	980 x 380 mm Stiel Ø 32 mm	1

Ø 23 mm



SPACHTEL MIT GUMMI

Nr.	Spezifikation	
15886	450 mm Stiel Ø 23 mm	48
15887	600 mm Stiel Ø 23 mm	48
15888	750 mm Stiel Ø 23 mm	32

ABZIEHPLATTE

MADE IN EU



Nr.	Spezifikation	
15885	100 x 800 mm Stiel Ø 32 mm	1

MATERIAL OBERFLÄCHE	BETON		PUTZ			KLEBSTOFF UND FUGENMÖRTEL	FASSADENKLEBER	GEBRAUCH
	GROB	ESTRICH	KERN	FEIN INNEN	FEIN YONG			
SCHWARZER FILZ (BRAUN, GRAU)				••••		••		Vergleich von Feinputz, für grobkörnige Putze
WEISSER FILZ				••••	••••	••••		Vergleich von Feinputz, für feinkörnigeren Putz
FEINSCHAUMSTOFF				••••	••••	••••		zum Entfernen von losem Sand, für feinen Stuck, zum Waschen von Fliesen nach dem Verfugen
GROBSCHAUMSTOFF				••••	••••	••••		Entfernung von losem Sand, auf rauem Stuck
AUFGERAUTER SCHAUMSTOFF				••••	••••	••••		Entfernung von losem Sand, dank der Rasterung werden raue Stellen des StucSt. besser erfasst, zum Waschen nach dem Verfugen
SEESCHWAMM					•••		••••	Abwaschen des Fugenmörtels
WASSERSCHWAMM GROB, FEIN					•		••••	Abwaschen des Fugenmörtels
SCHWAMM				••	••••	••	••••	abwaschen von Fugenmörtel, Ausarbeiten von Feinputz, Glätten von Stuckputz
MIKROGUMMI							••••	einpressen des Fugenmörtels in die Fuge
GUMMISCHAUM							••••	einpressen des Fugenmörtels in die Fuge
MIRELON		••••	•••					Betonverarbeiten, Kernverputzen
DUREN				••••	••	••••		Vergleich von Feinputz, im Allgemeinen zur Fertigstellung von Stuckputz
HOLZ	••••	••••	••••					Betonverarbeiten, Kernverputzen
STAHLBLECH	••	••••		••		••••	••	Betonglätten, unzugängliche Stellen
POLYSTYROL	•••	••••	•••	••		••		Betonverarbeiten, Kernverputzen
POLYURETHAN	••••	••••	••••					Betonverarbeiten, Kernverputzen
ABS		••		••••	••••	••••	••••	Kratz- und Rollputz, Auftragen von Kleber, Putz und Stuck, Feinverteilen, Spachteln
EDELSTAHL GLATT				••••	••••	••••	••••	Feinverteilen, Auftragen von Klebstoff, Putz und Stuck, Spannen von Fassadenkleber
EDELSTAHL GEZAHNT							••••	Verteilen von Fliesenkleber
SCHLEIFKELLE FÜR STYROPOR, KUNSTSTOFF			••				••••	Schleifen von Styropor, Schleifen von Zementleim
SCHLEIFKELLE FÜR STYROPOR, SPERRHOLZ			••				••••	Schleifen von Fassadenpolystyrol, Schleifen von Zementleim

**FESTA**KUNSTSTOFFGLÄTTER
MIT
WEISSEM FILZ

Č.p.	specifikace	
34400	280 x 140 x 8 mm	15
34415	250 x 130 x 8 mm	15
34450	220 x 130 x 8 mm	15
34445	220 x 70 x 8 mm	20

**FESTA**KUNSTSTOFFGLÄTTER
MIT
SCHWARZEM FILZ

Č.p.	specifikace	
34401	280 x 140 x 10 mm	15
34416	250 x 130 x 10 mm	15
34451	220 x 130 x 10 mm	15
34446	220 x 70 x 10 mm	20

**FESTA**KUNSTSTOFFGLÄTTER
MIT
FEINSCHAUMSTOFF

Č.p.	specifikace	
34404	280 x 140 x 30 mm	10
34485	280 x 130 x 20 mm	10
34486	250 x 130 x 30 mm	10
34419	250 x 130 x 20 mm	10
34453	220 x 130 x 20 mm	10
34447	220 x 70 x 20 mm	10

**FESTA**KUNSTSTOFFGLÄTTER
MIT
FEINEM SCHWAMM

Č.p.	specifikace	
34405	280 x 140 x 18 mm	15
34420	250 x 130 x 18 mm	15
34454	220 x 130 x 18 mm	15
34449	220 x 70 x 18 mm	20
34480	280 x 140 x 12 mm	15
34481	250 x 130 x 12 mm	15
34482	220 x 130 x 12 mm	15

**FESTA**KUNSTSTOFFGLÄTTER
MIT EXTRA FEINEM
SCHWAMM

Nr.	Spezifikation	
34443	280 x 140 x 12 mm	15
34442	250 x 130 x 12 mm	15

**FESTA**KUNSTSTOFFGLÄTTER
MIT GROBEM
SCHWAMM

Nr.	Spezifikation	
34441	280 x 140 x 12 mm	15
34440	250 x 130 x 12 mm	15
34439	250 x 130 x 18 mm	15



FESTA

KUNSTSTOFFGLÄTTER
MIT GERASTERTEM
SCHAUMSTOFF



Nr.	Spezifikation	
34409	280 x 140 x 30 mm	10
34425	250 x 130 x 20 mm	10

FESTA

KUNSTSTOFFGLÄTTER
MIT GROB-
SCHAUMSTOFF



Nr.	Spezifikation	
34410	280 x 140 x 30 mm	10
34426	250 x 130 x 20 mm	10

FESTA

KUNSTSTOFFGLÄTTER
MIT
MEERSCHWAMM



Č.p.	specifikace	
34406	280 x 140 x 30 mm	10
34421	250 x 130 x 30 mm	10
34455	220 x 130 x 30 mm	10

FESTA

KUNSTSTOFFGLÄTTER
MIT
MEERSCHWAMM,
GERASTERT



Č.p.	specifikace	
34413	280 x 140 x 30 mm	10
34428	250 x 130 x 30 mm	10

FESTA

KUNSTSTOFFGLÄTTER
MIT RAUEM
HYDROSCHWAMM



Č.p.	specifikace	
34412	280 x 140 x 30 mm	10
34424	250 x 130 x 30 mm	10
34458	220 x 130 x 30 mm	10

FESTA

KUNSTSTOFFGLÄTTER
MIT RAUEM
HYDROSCHWAMM,
GERASTERT



Č.p.	specifikace	
34490	280 x 140 x 30 mm	10
34491	250 x 130 x 30 mm	10

FESTA

KUNSTSTOFFGLÄTTER MIT
HYDROSCHWAMM
FEIN



Č.p.	specifikace	
34411	280 x 140 x 30 mm	10
34423	250 x 130 x 30 mm	10
34457	220 x 130 x 30 mm	10

FESTA

KUNSTSTOFFGLÄTTER
MIT
GUMMISCHAUM

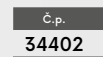

Č.p.	specifikace	
34402	280 x 140 x 10 mm	15
34417	250 x 130 x 10 mm	15
34452	220 x 130 x 10 mm	15

FESTA

KUNSTSTOFFGLÄTTER
MIT
MIKROGUMMI



Č.p.	specifikace	
34403	280 x 140 x 8 mm	15
34418	250 x 130 x 8 mm	15
34496	220 x 130 x 8 mm	15

FESTA

KUNSTSTOFFGLÄTTER
DUREN



Č.p.	specifikace	
34407	280 x 140 x 20 mm	10
34422	250 x 130 x 20 mm	10
34456	220 x 130 x 20 mm	10
34448	220 x 70 x 20 mm	10

FESTA

KUNSTSTOFFGLÄTTER
RUVEN



Č.p.	specifikace	
34414	280 x 140 x 20 mm	10
34429	250 x 130 x 20 mm	10

FESTA

KUNSTSTOFF-
GLÄTTER OHNE
OBERFLÄCHE

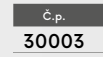

Č.p.	specifikace	
30003	270 x 125 mm	28
30004	235 x 115 mm	35
30005	210 x 115 mm	38
30007	210 x 60 mm	44

FESTA

FUGENGLÄTTER



MADE IN EU

Č.p.	specifikace	
34033	240 x 95 mm	5

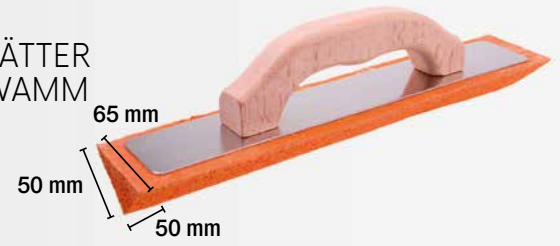
ECKENGLÄTTER
MIT SCHWAMM
90°

Č.p.	specifikace	
34500	350 mm	6

ERSATZOBERFLÄCHE
WEISSER FILZ

MADE IN EU

Č.p.	specifikace	
34241	280 x 140 x 8 mm	1
34223	250 x 130 x 8 mm	1

ERSATZOBERFLÄCHE
SCHWARZER FILZ

MADE IN EU

Č.p.	specifikace	
34243	280 x 140 x 10 mm	1
34221	250 x 130 x 10 mm	1

ERSATZOBERFLÄCHE
FEINER
SCHWAMM

MADE IN EU

Č.p.	specifikace	
34262	280 x 140 x 18 mm	1

ERSATZOBERFLÄCHE
FEINSCHAUM-
STOFF

MADE IN EU

Č.p.	specifikace	
34251	280 x 140 x 30 mm	1

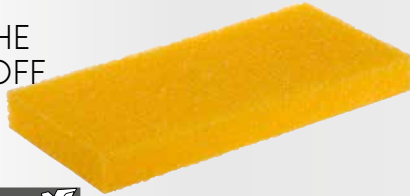
ERSATZOBERFLÄCHE
GROBSCHAUMSTOFF

MADE IN EU

Č.p.	specifikace	
34261	280 x 140 x 30 mm	1

ERSATZOBERFLÄCHE
MEERSCHWAMM

MADE IN EU

Č.p.	specifikace	
34265	280 x 140 x 30 mm	1

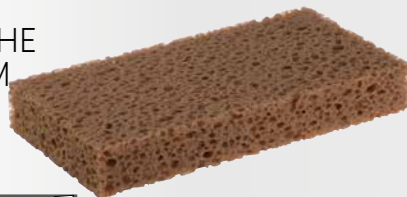
ERSATZOBERFLÄCHE
HYDROSCHWAMM
RAU

MADE IN EU

Č.p.	specifikace	
34238	280 x 140 x 30 mm	1

ERSATZOBERFLÄCHE
HYDROSCHWAMM
FEIN

MADE IN EU

Č.p.	specifikace	
34237	280 x 140 x 30 mm	1
34235	250 x 130 x 30 mm	1

ERSATZOBERFLÄCHE
GUMMISCHAUM

MADE IN EU

Č.p.	specifikace	
34231	280 x 140 x 10 mm	1



FESTA

ELEKTRISCHES RÜHRWERK FÜR BAUSTOFFE ZWEI QUIRLN

Anschlussleistung	1800 W
Spannung/Frequenz	230 V / 50 Hz
Geschwindigkeitsstufen	2
1. Gang (Leerlaufdrehzahl)	0 - 450 ot./min.
2. Gang (Leerlaufdrehzahl)	0 - 790 ot./min.
Überlastungsschutz	Ja
Durchmesser des Rührkorbs	100 mm
Rührerlänge	570 mm
Gewicht	5,6 kg



Č.p.	specifikace	
35311	Rührwerk	1
35318	Ersatzkohle	1
35319	Ersatzrührer - Paar (L+R)	1



FESTA

ELEKTRISCHES MISCHWERK FÜR BAUSTOFFE 1600 W

Anschlussleistung	1600 W
Spannung/Frequenz	230 V / 50 Hz
Geschwindigkeitsstufen	2
1. Gang (Leerlaufdrehzahl)	0 - 480 ot./min.
2. Gang (Leerlaufdrehzahl)	0 - 800 ot./min.
Überlastungsschutz	Ja
Rührergewinde	M 14
Durchmesser des Rührkorbs	140 mm
Rührerlänge	600 mm
Gewicht	4,7 kg



Č.p.	specifikace	
35310		1
35317	Ersatzkohle	1

FESTA

ELEKTRISCHES MISCHWERK FÜR BAUSTOFFE 850 W

Anschlussleistung	850 W
Spannung/Frequenz	230 V / 50 Hz
Geschwindigkeitsstufen	1
1. Gang (Leerlaufdrehzahl)	0 - 500 ot./min.
2. Gang (Leerlaufdrehzahl)	-
Überlastungsschutz	Ja
Rührergewinde	M 14
Durchmesser des Rührkorbs	120 mm
Rührerlänge	600 mm
Gewicht	3,7 kg



Č.p.	specifikace	
35300		1
35316	Ersatzkohle	1

**WEST
BERG****ELEKTRISCHES MISCHWERK FÜR BAUSTOFFE 1600 W**

Anschlussleistung	1600 W
Spannung/Frequenz	230 V / 50 Hz
Geschwindigkeitsstufen	2
1. Gang (Leerlaufdrehzahl)	180 - 400 ot./min.
2. Gang (Leerlaufdrehzahl)	300 - 700 ot./min.
Überlastungsschutz	Ja
Rührergewinde	M 14
Durchmesser des Rührkorbs	140 mm
Rührerlänge	600 mm
Gewicht	5,4 kg

M14 Zn CE

C.p.	spezifikace	
35305		1
35315	Ersatzkohle	1

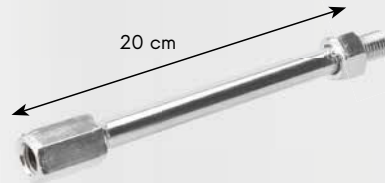
**NEW****FESTA****RÜHRER-
VERLÄNGERUNG****M14**

Nr.	Spezifikation	
35142	M14	1

**NEW****FESTA****RÜHRER MIT RING RECHTSDREHEND**

Spiralquirl mit drei Armen und Ring, rechtsdrehend - für schwere Materialien mit hoher Viskosität. Mörtel, Betone, Zement- und Kalkputze, Klebmassen, Estriche, Epoxidharze, bituminöse Beschichtungen - Mischeffekt von unten nach oben - der Quirl wird wie eine Schraube in das Material eingezogen.

Zn	M14	Nr.	Spezifikation		
		35085	M14 Ø 120 x 600 mm	12	
		35086	M14 Ø 140 x 600 mm	12	
		35087	M14 Ø 160 x 600 mm	12	

**FESTA****RÜHRER MIT RING LINST.DREHEND**

Spiralquirl mit drei Armen und Ring linSt.drehend - für dünnflüssige Mischungen in großen Mengen. Das gemischte Material wird nach unten gedrückt. Das dünnflüssige Material spritzt nicht aus dem Behälter, die abgelagerten Farbpigmente steigen auf und vermischen sich ideal.

Zn	M14	Nr.	Spezifikation		
		35091	M14 Ø 120 x 600 mm	12	
		35092	M14 Ø 140 x 600 mm	12	
		35093	M14 Ø 160 x 600 mm	12	

**FESTA****RÜHRER MIT RING**

Spiralrührer mit zwei Armen - zum gründlichen Anmischen von Fliesenklebern, Fugenmassen, Klebemörteln, Fertigputzen, Estrichen, Spachtelmassen, Ausgleichsmassen.

	Zn	Nr.	Spezifikation	
		35038	Ø 80 x 500 mm	24
		35058	Ø 100 x 500 mm	24
		35023	Ø 120 x 500 mm	24



FESTA

RÜHRER MIT RING

Spiralrührer mit zwei Armen - zum gründlichen Anmischen von Fliesenklebern, Fugenmassen, Klebemörteln, Fertigputzen, Estrichen, Spachtelmassen, Ausgleichsmassen.

SDS+	Zn	Nr.	Spezifikation	
		35094	Ø 80 x 500 mm	24
		35095	Ø 100 x 500 mm	24
		35096	Ø 120 x 500 mm	24



FESTA

RÜHRER MIT RING

Spiralrührer mit zwei Armen - zum gründlichen Anmischen von Fliesenklebern, Fugenmassen, Klebemörteln, Fertigputzen, Estrichen, Spachtelmassen, Ausgleichsmassen.

M14	Zn	Nr.	Spezifikation	
		35059	M14 Ø 90 x 550 mm	24



FESTA

RÜHRER MIT RING, VERLÄNGERTE SPIRALE

Spiralrührer mit zwei Armen - zum gründlichen Anmischen von Fliesenklebern, Fugenmassen, Klebemörteln, Fertigputzen, Estrichen, Spachtelmassen, Ausgleichsmassen.

	Zn	Nr.	Spezifikation	
		35013	Ø 80 x 500 mm	24
		35006	Ø 100 x 500 mm	24
		35007	Ø 120 x 500 mm	24

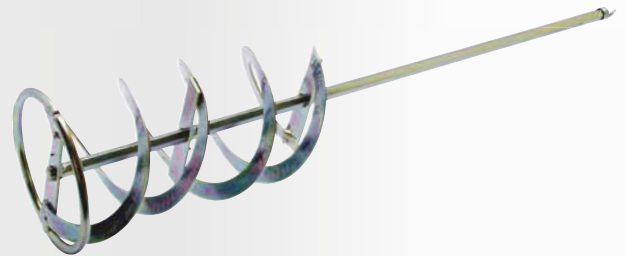

FESTA

RÜHRER MIT RING, VERLÄNGERTE SPIRALE

Spiralrührer mit zwei Armen - zum gründlichen Anmischen von Fliesenklebern, Fugenmassen, Klebemörteln, Fertigputzen, Estrichen, Spachtelmassen, Ausgleichsmassen.

SDS+	Zn	Nr.	Spezifikation		
		35012	Ø 100 x 500 mm	24	



FESTA

SPIRALDRAHTRÜHRER

Spiralrührer mit zwei Armen - zum gründlichen Anmischen von Fliesenklebern, Fugenmassen, Klebemörteln, Fertigputzen, Estrichen, Spachtelmassen, Ausgleichsmassen.

	Zn	Nr.	Spezifikation	
		35069	Ø 60 x 500 mm	50
		35078	Ø 80 x 500 mm	24
		35081	Ø 100 x 500 mm	24



FESTA

SPIRALDRAHTRÜHRER

Spiralrührer mit zwei Armen - zum gründlichen Anmischen von Fliesenklebern, Fugenmassen, Klebemörteln, Fertigputzen, Estrichen, Spachtelmassen, Ausgleichsmassen.

SDS+	Zn	Nr.	Spezifikation	
		35070	Ø 60 x 500 mm	50
		35079	Ø 80 x 500 mm	24
		35082	Ø 100 x 500 mm	24



FESTA**RÜHRER OHNE RING**

Spiralrührer mit zwei Armen - zum gründlichen Anmischen von Fliesenklebern, Fugenmassen, Klebemörteln, Fertigputzen, Estrichen, Spachtelmassen, Ausgleichsmassen.

Nr.	Spezifikation	
35048	Ø 70 x 500 mm	24
35068	Ø 90 x 500 mm	24

**FESTA****RÜHRER OHNE RING**

Spiralquirl - für hochviskose und klebrige Materialien wie Baukleber und Dichtstoffe, Putze, Estriche usw. Das Material strömt von unten nach oben.

Nr.	Spezifikation	
35021	Ø 90 x 500 mm	24

**FESTA****KELCHRÜHRER**

Käfig-Quirl - für Materialien, bei denen Luftpneinschlüsse im Gemisch unerwünscht sind. Für dünne Nivelliermassen, Spachtelmassen, Dichtstoffe, Klebstoffe.

Nr.	Spezifikation	
35015	Ø 100 x 500 mm	20

**FESTA****PROPELLERRÜHRER**

Propeller-Quirl - für flüssige Materialien, Farben, Lacke, Wand- und Dispersionsklebstoffe für Tapeten, Fliesenkleber.

Nr.	Spezifikation	
35011	Ø 80 x 500 mm	50

**RÜHRER MIT RING**

Bogenrührer mit Ring - zum gründlichen Anmischen von Wandfarben, Dispersionsfarben, Klebern, Lacken.

Nr.	Spezifikation	
35125	Ø 60 x 400 mm	40
35126	Ø 80 x 400 mm	40
35127	Ø 100 x 600 mm	20

**RÜHRER MIT RING, LACKIERT**

Bogenrührer mit Ring - zum gründlichen Anmischen von Wandfarben, Dispersionsfarben, Klebern, Lacken.

Nr.	Spezifikation	
35103	Ø 60 x 400 mm	40
35113	Ø 80 x 400 mm	40
35123	Ø 100 x 600 mm	20



FESTA



PROFESSIONAL BAUMISCHMASCHINEN

Lescha

Baumischmaschinen für die anspruchsvollsten professionellen Anwendungen
 Zahnkrone aus Gusseisen mit patentierter Befestigung
 Einstellbares Zahnspiel
 Hochwertige Oberflächenbehandlung
 Doppelte Lagerung auf dem Boden der Trommel
 Patentierte Schutzisolierung, Qualitätsschutz nach DIN EN ISO 9001
 Speziell entwickelte Trommelform
 Spritzwasserschutz IP 45
 Erhältlich in den Versionen 230V und 400V



Lescha BAUSTELLENMISCHER



Nr.	Spezifikation	
35500	Star 150 - 125 l, 230 V Fußbremse	1



Lescha BAUSTELLENMISCHER



Nr.	Spezifikation	
35502	EUROMIX 125 l, 230 V	1
35503	EUROMIX 125 l, 400 V	1



Lescha BAUSTELLENMISCHER



Nr.	Spezifikation	
35501	BX 135 - 125 l, 230 V	1



Lescha BAUSTELLENMISCHER



Nr.	Spezifikation	
35504	ABM 135 l, 230 V Fußbremse	1



Lescha BAUSTELLENMISCHER



Nr.	Spezifikation	
35505	SM 145 S - 140 l, 230 V	1
35506	SM 145 S - 140 l, 400 V	1
35507	SM 145 S - 140 l, 230 V Fußbremse	1
35508	SM 145 S - 140 l, 400 V Fußbremse	1



Lescha BAUSTELLENMISCHER



Nr.	Spezifikation	
35510	SM 165 S - 160 l, 230 V Fußbremse	1
35511	SM 165 S - 160 l, 400 V Fußbremse	1
35512	SM 165 S - 160 l, G Benzin	1



Lescha BAUSTELLENMISCHER



Nr.	Spezifikation	
35514	SM 185 S - 180 l, 230 V Fußbremse	1
35515	SM 185 S - 180 l, 400 V Fußbremse	1



Lescha BAUSTELLENMISCHER



Nr.	Spezifikation	
35516	S 180 HR - 180 l, 230 V Fußbremse	1
35517	S 180 HR - 180 l, 400 V Fußbremse	1



Lescha
BAUSTELLENMISCHER



Nr.	Spezifikation	
35524	LB 354 230 V, 1,5 kW	1
35525	LB 354 400 V, 1,5 kW	1
35527	LB 354 Honda G200	1
35532	LB 404 230 V, 1,5 kW	1
35533	LB 404 400 V, 1,5 kW	1
35539	LB 484 Robin EH17B	1
35540	LB 484 Honda GX160LX	1
35542	AT 480 400 V, 1,2 kW	1

Lescha
BAUSTELLENMISCHER



Nr.	Spezifikation	
35518	S 230 HR - 230 l, 230 V Fußbremse	1
35519	S 230 HR - 230 l, 400 V Fußbremse	1

Lescha
BAUSTELLENMISCHER



Nr.	Spezifikation	
35552	LHB 1000 400 V	1
35553	LHB 1000 HATZ Diesel	1
35555	LHB 1200 400 V	1



ALTRAD
BAUSTELLENMISCHER



Nr.	Spezifikation	
37500	MIX 130Zk 230 V zerlegt	1
37501	MIX 130Z 230 V gefaltet	1
37505	MK 165Bk 230 V zerlegt	1
37506	MK 165B 230 V gefaltet	1

130 L

Spezifikation	
Trommelvolumen	130 l
Trommeldrehzahl	26±Min ⁻¹
Leistung	700 W
Spannung	230 V / 50 Hz
Schutzart	IP44
Kranzmaterial	Gusseisen
Abmessungen	Länge 1170 mm
	Breite 650 mm
	Höhe 1280 mm
Gewicht	53 kg

165 L

Spezifikation	
Trommelvolumen	165 l
Trommeldrehzahl	23±Min ⁻¹
Leistung	900 W
Spannung	230 V / 50 Hz
Schutzart	IP44
Kranzmaterial	Gusseisen
Abmessungen	Länge 1295 mm
	Breite 735 mm
	Höhe 1440 mm
Gewicht	70 kg

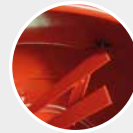

· Speziell gefertigte Klingen, 4 mm dick



· Qualitätsstützlager mit Deckel



· Schalter mit Sicherheitskappe



· Antriebsdeckel aus Kunststoff, Kranz aus Gusseisen

BAUSTELLENMISCHER



125 L

Spezifikation	
Trommelvolumen	125 l
Trommeldrehzahl	26±Min ⁻¹
Leistung	550 W
Spannung	230 V / 50 Hz
Schutzart	IP44
Kranzmaterial	Gusseisen
Abmessungen	Länge 1102 mm Breite 690 mm Höhe 1310 mm
Gewicht	52,5 kg

Nr.	Spezifikation	
37509	126 l, 230 V	zusammengebaut 1
37510	126 l, 230 V	aufgeklappt 1

162 L

Spezifikation	
Trommelvolumen	162 l
Trommeldrehzahl	26±Min ⁻¹
Leistung	650 W
Spannung	230 V / 50 Hz
Schutzart	IP44
Kranzmaterial	Gusseisen
Abmessungen	Länge 1180 mm Breite 710 mm Höhe 1310 mm
Gewicht	56 kg

Nr.	Spezifikation	
37515	162 l, 230 V	aufgeklappt 1
37516	162 l, 230 V	zusammengebaut 1

142 L

Spezifikation	
Trommelvolumen	142 l
Trommeldrehzahl	26±Min ⁻¹
Leistung	650 W
Spannung	230 V / 50 Hz
Schutzart	IP44
Kranzmaterial	Gusseisen
Abmessungen	Länge 1164 mm Breite 690 mm Höhe 1293 mm
Gewicht	54 kg

Nr.	Spezifikation	
37511	142 l, 230 V	aufgeklappt 1
37512	142 l, 230 V	zusammengebaut 1

180 L

Spezifikation	
Trommelvolumen	180 l
Trommeldrehzahl	26±Min ⁻¹
Leistung	850 W
Spannung	230 V / 50 Hz
Schutzart	IP44
Kranzmaterial	Gusseisen
Abmessungen	Länge 1164 mm Breite 690 mm Höhe 1368 mm
Gewicht	58 kg

Nr.	Spezifikation	
37517	180 l, 230 V	aufgeklappt 1
37518	180 l, 230 V	zusammengebaut 1



SCHUBKARRE



Nr.	Spezifikation	
37530	60 l, Ø 38 cm	selbsttragendes Rad 1
37532	60 l, Ø 40 cm	aufblasbar 1



SCHUBKARRE VERZINKT



Nr.	Spezifikation	
37527	80 l, Ø 40 cm	aufblasbar 1
37533	80 l, Ø 38 cm	selbsttragendes Rad 1

KASTEN
SCHWARZ

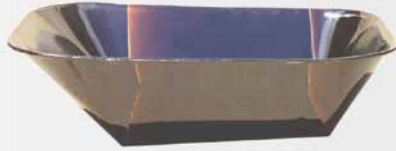

Nr.	Spezifikation	
37539	60 l	1

KASTEN
VERZINKT



Nr.	Spezifikation	
37541	80 l	1

ERSATZRÄDER



Nr.	Spezifikation	
48729	typ AA 400 aufblasbar	1
48730	typ AA 380 selbsttragend	1
48731	typ AA 380 selbsttragend	1

DREI-RAD-
SCHUBKARRE



Nr.	Spezifikation	
37564	60 l	1

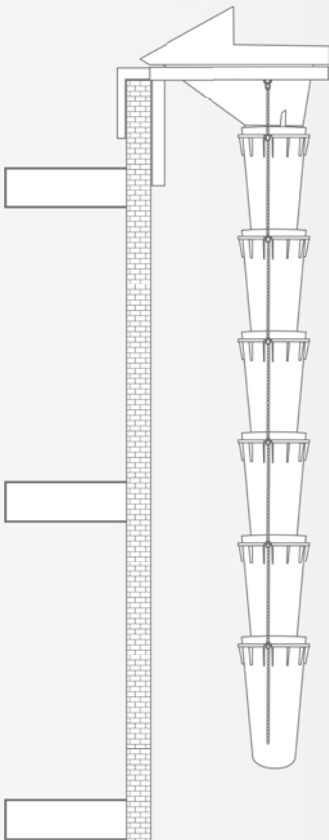

Lescha

BAUSCHUTTDEPONIE



Nr.	Spezifikation	
35603	Bodendurchmesser 50/40 cm, Länge 108 cm PE (HDPE)	1
35604	Bauschuttcontainer PE (HDPE)	1
35605	Tragrahmen für den Bauschuttcontainer	1

HORIZONT®



HORIZONT®

ABZIEHLATTE - OHNE LIBELLEN

ALU

Nr.	Spezifikation	
15310	100 cm	10
15315	150 cm	10
15318	180 cm	10
15320	200 cm	10
15325	250 cm	10
15330	300 cm	10
15335	350 cm	10
15340	400 cm	10



HORIZONT®

ABZIEHLATTE - 1 LIBELLE

ALU

Nr.	Spezifikation	
15415	150 cm	10
15418	180 cm	10
15420	200 cm	10
15425	250 cm	10
15430	300 cm	10



HORIZONT®

ABZIEHLATTE - 2 LIBELLEN

ALU

Nr.	Spezifikation	
15510	100 cm	10
15515	150 cm	10
15518	180 cm	10
15520	200 cm	10
15525	250 cm	10
15530	300 cm	10
15535	350 cm	10
15540	400 cm	5



HORIZONT®

ABZIEHLATTE - 2 GRIFFE, OHNE LIBELLE

ALU

Nr.	Spezifikation	
15615	150 cm	10
15620	200 cm	10
15625	250 cm	10
15630	300 cm	10



HORIZONT®

ABZIEHLATTE - 2 GRIFFE, 2 LIBELLEN

ALU

Nr.	Spezifikation	
15710	100 cm	10
15715	150 cm	10
15720	200 cm	10
15725	250 cm	10
15730	300 cm	10
15735	350 cm	10
15740	400 cm	5





HORIZONT
ABZIEHLATTE - 1 TRAPEZPROFIL

TRAPEZ
· Das Trapezprofil wird für feinere Oberflächenanpassungen verwendet
· geeignet für Stuckateure und Fassadenarbeiter
· geeignet für Dünnschichtputze

ALU	Nr.	Spezifikation	
	15810	100 cm	10
	15812	120 cm	10
	15815	150 cm	10
	15818	180 cm	10
	15820	200 cm	10
	15825	250 cm	10
	15830	300 cm	10



HORIZONT
ABZIEHLATTE - 1 H-PROFIL

PROFIL "h"
· Das "h"-Profil wird für feinere Oberflächenanpassungen verwendet
· geeignet für Stuckateure und Fassadenarbeiter
· geeignet zum Stuckieren von Deckenputzen

ALU	Nr.	Spezifikation	
	15850	100 cm	10
	15853	150 cm	10
	15855	180 cm	10
	15860	200 cm	10
	15870	250 cm	10
	15880	300 cm	10



NEW

HORIZONT
KUPPLUNG FÜR ABZIEHLATTE HORIZONT

Nr.	Spezifikation		
15301		1	



HORIZONT
EINSTELLBARE ABZIEHLATTE

Nr.	Spezifikation		
15893	65 - 100 cm	1	
15894	95 - 150 cm	1	
15895	145 - 235 cm	1	



HORIZONT
MAURERWINKEL

ALU	Nr.	Spezifikation	
	14485	800 x 1200 mm	1
	14486	1000 x 1500 mm	1



**FESTA****BIEGEMASCHINE FÜR EISENSTANGEN**

Nr.	Spezifikation	
26730	Ø 6 - 14 mm	1
26731	Ø 5 - 8 mm	1

**NEW****FESTA****PFLASTERHALTER**

Nr.	Spezifikation	
60130	27 - 45 cm	10

NEW**FESTA****PFLASTERHALTER**

Nr.	Spezifikation	
60132		1

NEW**FESTA****BORDSTEIN-
WAGEN**

· max 150 kg



Nr.	Spezifikation	
60157		1

**STANGENBIEGER**

Nr.	Spezifikation	
26735	max Ø 13 mm 56 cm	1

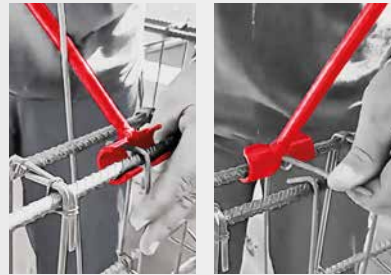
**NEW****STANGENBIEGER**

· Ø 4-8 mm

Nr.	Spezifikation	
26736		1

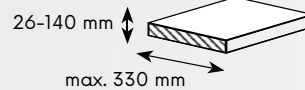
NEW**FESTA****STEINE KNACKEN**

· max 45 kg

Nr.	Spezifikation	
60125		1

**NEW****FESTA****BORDSTEIN-
WAGEN**

· max 100 kg



Nr.	Spezifikation	
60155		1



30 - 50 cm

HALTER FÜR FLIESEN VERSTELLBAR

Nr.	Spezifikation	
36310	max. 20kg	5



BORDSTEINTRÄGER

Spezifikation	60116
Kieferngröße:	750-1000 mm
max. Belastung:	120 kg

Nr.	Spezifikation	
60116	PRO 041	1



SCHLEGEL ZUM AUSGLEICHEN VON REIHEN

Spezifikation	60121	60123
Höhe	200 mm	200 mm
Breite	70 kg	70 kg
Dauer	870 mm	450 mm
Gewicht	2,5 kg	2,2 kg

Nr.	Spezifikation	
60121	870 mm	1
60123	450 mm	1



BORDSTEINTRÄGER

Spezifikation	60115
Kieferngröße:	80-370 mm
max. Belastung:	50 kg

Nr.	Spezifikation	
60115	PRO 040	1



BORDSTEINTRÄGER

Spezifikation	60117	60118
Kieferngröße:	500-1000 mm	0-500 mm
max. Belastung:	150 kg	150 kg

Nr.	Spezifikation	
60117	PRO 042	1
60118	PRO 043	1



NIVELLIERMATTE UNTER PFLASTERUNG

Nr.	Spezifikation	
37166	D10 Basis	25



MAURERROLLE AUS 500

Nr.	Spezifikation	
26780	0,5t A mit Haken	1
26781	0,5t B mit Öse	1
26782	0,5t C mit Haken und Schutzvorrichtung	1
26783	0,5t D mit Öse und Schutzvorrichtung	1

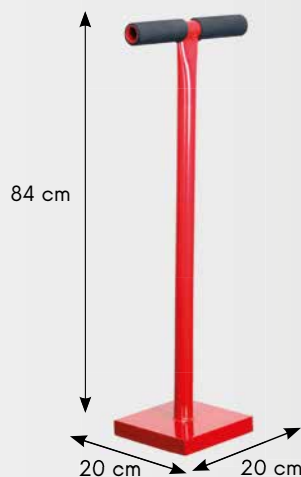

84 cm

20 cm 20 cm

HANDSTAMPFER

Nr.	Spezifikation	
26740	12 kg	1



STECKKARRE

Nr.	Spezifikation	Tragfähigkeit	
48719	260 mm Bantam-Rad	250 kg	1



PROFI-FLIESENSCHNEIDER

- Pflasterschneider für den anspruchsvollen professionellen Einsatz
- das Fahrwerk ist mit 9 gekapselten skf-Kugellagern ausgeführt,
- 4 sind einstellbar und bestimmen den Spielraum des FahrwerSt.
- gefederte Tische
- kann auch für linSt.händiges Arbeiten komplettiert werden
- alle Ersatzteile und Serviceleistungen
- Trennscheiben aus Chrom-Wolfram-Stahl

SUPER PRO



SUPER PRO „EVO“ PFLASTERSCHNEIDER

· 36195 Ersatz-Schneidrad - Ø 22 mm



Nr.	Spezifikation
36191	1250 mm

1

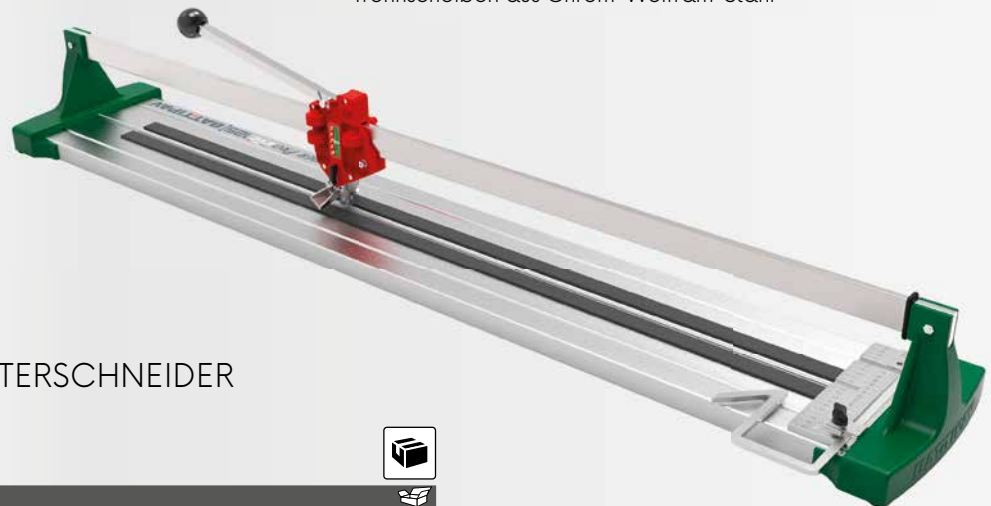

SUPER PRO



SUPER PRO PFLASTERSCHNEIDER

· 36195 Ersatz-Schneidrad - Ø 22 mm



Nr.	Spezifikation
36145	SUPER PRO 450 mm
36160	SUPER PRO 600 mm
36175	SUPER PRO 750 mm
36190	SUPER PRO 900 mm

1

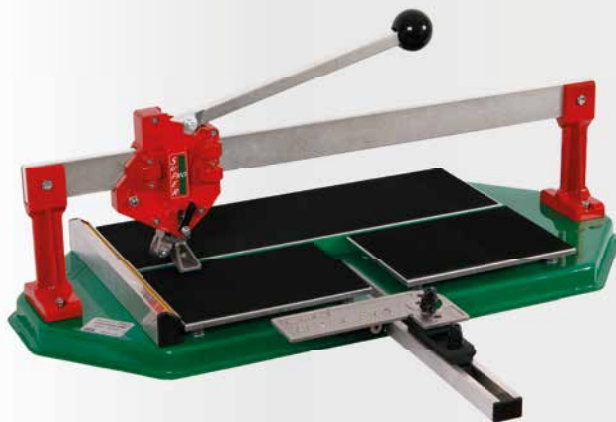

Beispielfoto

VERKAUFSSTAND SUPER PRO



Nr.	Spezifikation	
36200	Verkaufsstand	1
36199	Verkaufsstand ausgestattet 36160, 36175, 36190	1



FESTA

„X“ PFLASTERSCHNEIDER

· 36138 Ersatz-Schneidrad - Ø 22 mm



Nr.	Spezifikation	
36085	600 mm	1
36087	900 mm	1
36086	1300 mm	1



NEW

FESTA

PFLASTERSCHNEIDER

· 36139 Ersatz-Schneidrad - Ø 22 mm



Nr.	Spezifikation	
36102	1050 mm	1
36103	1300 mm	1
36105	1550 mm	1



FESTA

PFLASTERSCHNEIDER

· 36195 Ersatz-Schneidrad - Ø 22 mm



Nr.	Spezifikation	
36080	600 mm	1
36081	750 mm	1
36082	900 mm	1
36076	750 mm zusammengesetzt	1
36077	900 mm zusammengesetzt	1



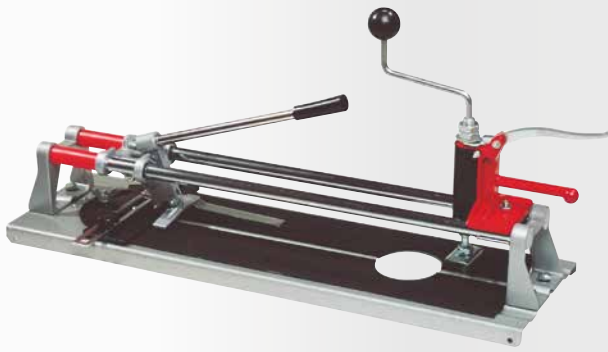

PFLASTERSCHEIDER MIT KREISSCHNEIDER

· 36128 Ersatz-Schneidrad - Ø 16 mm



Nr.	spezifikation	
36014	480 mm	4



PFLASTERSCHEIDER

· 36126 Ersatz-Schneidrad - Ø 15 mm



Nr.	spezifikation	
36024	300 mm	10
36034	400 mm	10
36035	600 mm	4



PFLASTERSCHEIDER

· 36136 Ersatz-Schneidrad - Ø 22 mm



Nr.	spezifikation	
36036	480 mm	1



HANDPFLASTERSCHEIDER

· 36136 Ersatz-Schneidrad - Ø 22,2 mm



Nr.	spezifikation	
36046	22 mm	1

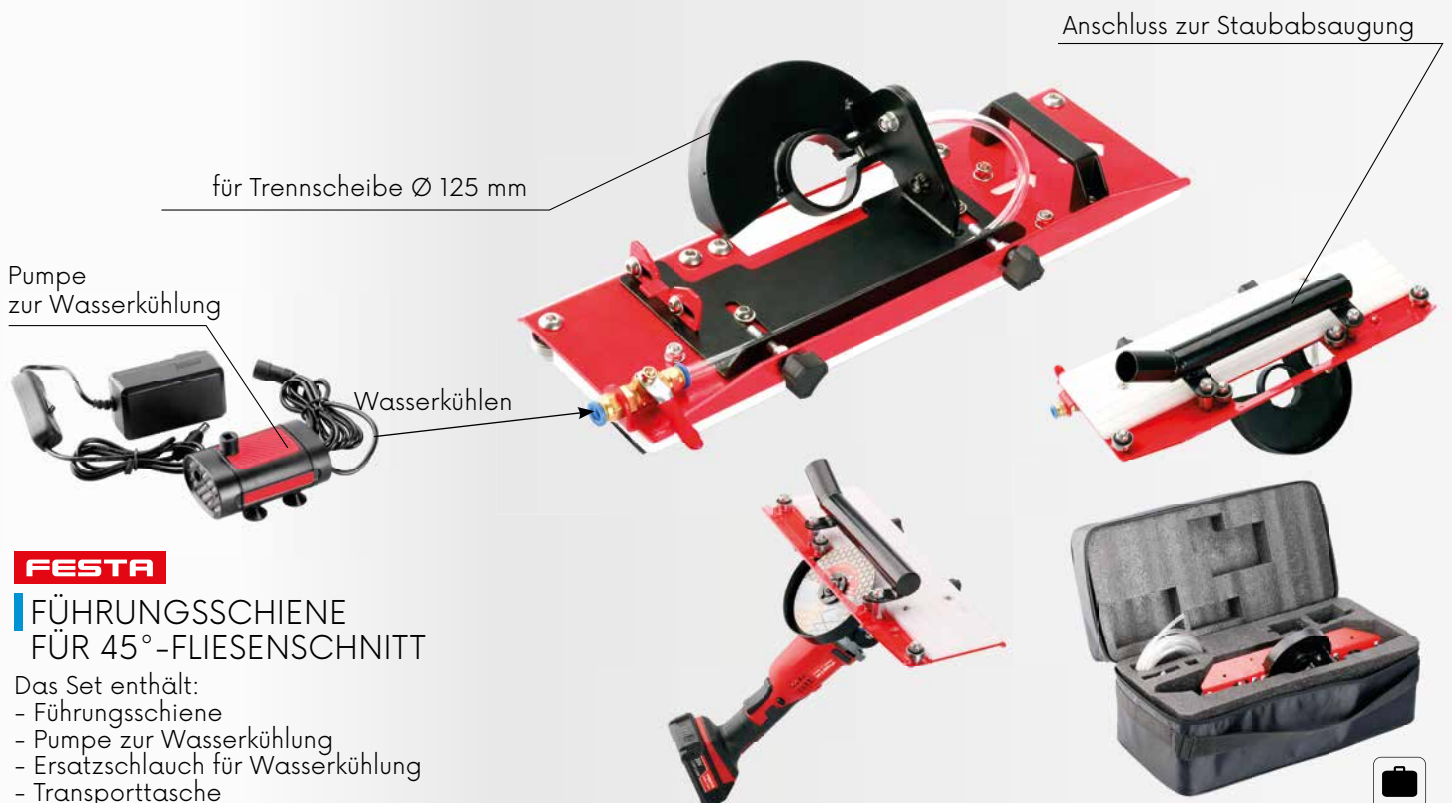

FESTA

FÜHRUNGSSCHIENE FÜR 45°-FLIESENSCHNITT

Das Set enthält:

- Führungsschiene
- Pumpe zur Wasserkühlung
- Ersatzschlauch für Wasserkühlung
- Transporttasche

Nr.	spezifikation	
24680		1

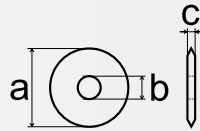

ERSATZRAD FÜR PFLASTERSCHNEIDER



Broj	specifikacija	
36126	a= Ø 15 mm, b= Ø 6 mm, c= 1,5 mm	1
36128	a= Ø 16 mm, b= Ø 6 mm, c= 3 mm	1
36130	a= Ø 20 mm, b= Ø 6 mm, c= 5 mm	1
36136	a= Ø 22 mm, b= Ø 6 mm, c= 2 mm	1
36138	a= Ø 22 mm, b= Ø 6 mm, c= 5 mm	1
36139	a= Ø 22 mm, b= Ø 6 mm, c= 6 mm	1
36195	a= Ø 22 mm, b= Ø 6 mm, c= 4,8 mm	1



GERADE SÄGE FÜR FLIESEN UND KERAMIK

Nr.	specifikace	
24055	Karbid - BOSCH, MAKITA	1



FESTA

FLIESENZANGE



Nr.	specifikace	
36057	200 mm	6



FLIESENZANGE



Nr.	specifikace	
36056		10



KERAMIK-SCHNEIDEZANGE

Nr.	specifikace	
36059		1



ZANGE (PAPAGEI)

Nr.	specifikace	
36058	200 mm	6



FESTA

VINYL- UND LAMINATSCHNEIDER



Nr.	Spezifikation	
36140	210 mm	4



NEW



FESTA

SILIKON-APPLIKATOR



Nr.	Spezifikation
37050	

1



FESTA

SILIKON-APPLIKATOR



Nr.	Spezifikation
16056	145 mm

50

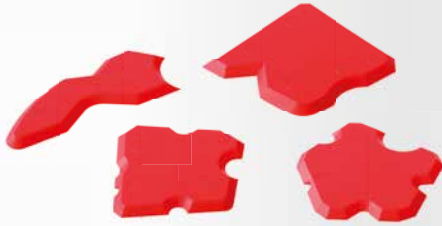

SILIKON-SPREADER SET

4x



Nr.	Spezifikation
37052	

1



SILIKON-SPREADER SET

4x



Nr.	Spezifikation
37053	

48



SPACHTEL

Nr.	Spezifikation
37054	

1



SPACHTEL

zum Verfugen von Fenstern

Nr.	Spezifikation
37055	zum Verfugen von Fenstern

1



HOLZSPACHTEL MIT GUMMI

Nr.	Spezifikation
37011	180 mm
37021	280 mm

12

12



37028



37029



37025



37026

AUSWASCHSCHWAMM 160 X 110 X 60 MM

Nr.	spezifikation
37028	Hydroschwamm
37029	Seeschwamm

1

1

AUSWASCHSCHWAMM 200 X 100 X 100 MM

Nr.	spezifikation
37025	Feinschaumstoff
37026	Seeschwamm

1

1



AUSWASCHBECKEN

Nr.	spezifikation
37117	Set
90070	Behälter 25 l

1

1

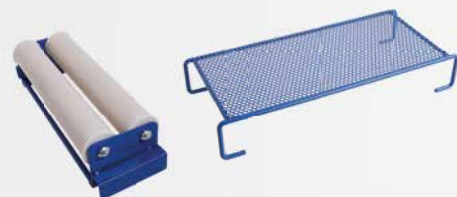

AUSWASCHBECKEN - ZUBEHÖR

Nr.	spezifikation
90072	Gitter
90071	Metallrollen

1

1



4 mm

FUGENREINIGER



Nr.	Spezifikation	
37012		1



37006

37007

FUGENREINIGER

Nr.	Spezifikation	
37006	30 mm	20
37007	50 mm	20
37008	Ersatzklinge 30 mm	50
37009	Ersatzklinge 50 mm	50



SET ZUM AUFTRAGEN UND ENTFERNEN VON SILIKON

3x



Nr.	Spezifikation	
16042		12

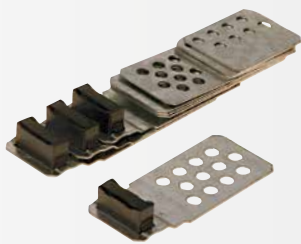

MAGNETE UNTER VERKLEIDUNG



4x



Nr.		
38920		1



MAGNETE UNTER VERKLEIDUNG, VERSTELLBAR



4x



Nr.		
38923		24

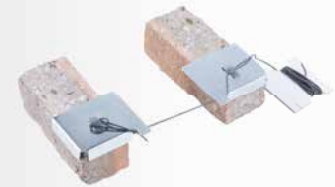

BAUECKEN - SET

Nr.		
38919		50



FUGENPISTOLE

Volumen 1,5 l



Nr.	Spezifikation	
38026	5x Spitze	25



NEW

- Ø 10 mm
- Ø 14 mm
- Ø 20 mm
- Ø 10 x 35 mm

3 l



Ø 10 mm

FESTA FUGENAPPLIKATOR

Nr.	Spezifikation	
38045		1



FUGENSACK



Nr.	Spezifikation	
38042	3x Spitze	6



MONTAGE-SET FÜR SCHWIMMEND VERLEGTE FUSSBÖDEN

24x

Nr.	Spezifikation	St.
52130		1



MONTAGEKEILE - KUNSTSTOFF

50x

Nr.	Spezifikation	St.
37210	95 x 45 x 15 - 0 mm	50
37211	70 x 30 x 8 - 0 mm	50



MONTAGEPOLSTER, ERWEITERBAR

· Abmessungen 15x17 cm
· max. Höhe 5 cm

Nr.	Spezifikation	St.
37220		1



AUSGLEICHSSCHEIBE

30x

Nr.	Spezifikation	St.
37212	1 - 6 mm, 5 St. von jeder Größe	1

FESTA MONTAGEKEILE HOLZ

Nr.	Spezifikation	St.
37204	55 x 20 x 0 - 6 mm	20
37203	65 x 18 x 0 - 12 mm	20
37202	80 x 25 x 3 - 10 mm	20
37201	100 x 25 x 1 - 16 mm	14
37200	150 x 25 x 1 - 25 mm	8

FESTA FLIESSENKEILE

Nr.	Spezifikation	St.
37155	0 - 8 mm	30
37156	0 - 4 mm	100
37157	2,5 - 8 mm	30

FESTA MONTAGEKEILE HOLZ

250x

Nr.	Spezifikation	St.
37205	55 x 8 x 0 - 10 mm	250



NIVELYS FUNDAMENTPROFIL UNTER FLIESEN

ALU

Nr.	Spezifikation	St.
37105	50 cm	1
37106	100 cm	1
37107	150 cm	1



NIVELYS VERSTELLBARE FÜSSE FÜR FUNDAMENTPROFIL

· max. 50 kg

2x

Nr.	Spezifikation	St.
37102		1

NIVELYS

LEVELING SYSTEMS

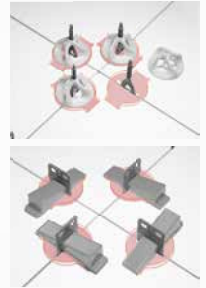

NIVELYS
LEVELING SYSTEMS FESTA

DISTANZKLAMMER MIT GEWINDE

50x

Nr.	Spezifikation	St.
37131	1 mm	40
37132	2 mm	40

NIVELYS
LEVELING SYSTEMS FESTA

NIVELLIERKAPPE MIT GEWINDE

50x

Nr.	Spezifikation	St.
37130	wieder verwendbar	15

NIVELYS
LEVELING SYSTEMS FESTA

SCHUTZPLATTEN FÜR FLIESENNIVELLIERSYSTEME

100x

Nr.	Spezifikation	St.
37192		1

NIVELYS
LEVELING SYSTEMS FESTA

DISTANZKLAMMERN

· Nivellierkeile 37175, 37176

50x

Nr.	Spezifikation	St.
37170	1 mm	50
37171	2 mm	50
37172	3 mm	50

NIVELYS
LEVELING SYSTEMS FESTA

DISTANZKLAMMERN

100x

Nr.	Spezifikation	St.
37185	1 mm	100
37190	1,5 mm	100
37186	2 mm	100
37187	3 mm	100
37188	4 mm	100
37189	5 mm	100

NIVELYS
LEVELING SYSTEMS FESTA

DISTANZKLAMMERN

100x

Nr.	Spezifikation	St.
37162	1,5 mm	1

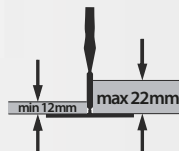

NIVELYS
LEVELING SYSTEMS FESTA

NIVELLIERKEILE

Nr.	St.
37175	50
37176	400



NIVELYS
LEVELING SYSTEMS FESTA

NIVELYS
LEVELING SYSTEMS **FESTA**

DISTANZKLAMMERN

600x

Nr.	Spezifikation	St.	Box	
37125	1 mm	600	38 x 28 x 19 cm	1
37126	1,5 mm	600	38 x 28 x 19 cm	1
37127	2 mm	600	38 x 28 x 19 cm	1



NIVELYS
LEVELING SYSTEMS **FESTA**

NIVELLIERSET

Nr.	Spezifikation	
37173	Klammern 1 mm, 400 Stück + Keile 200 Stück	1
37174	Klammern 1,5 mm, 400 Stück + Keile 200 Stück	1



NIVELYS
LEVELING SYSTEMS **FESTA**

NIVELLIERZANGE

Nr.
37177



1

NIVELYS
LEVELING SYSTEMS **FESTA**

NIVELLIERZANGE

Nr.
37178



1

NIVELLIERCLIP

50x

Nr. Spezifikation
37199 1,5 mm



40

NIVELYS
LEVELING SYSTEMS **FESTA**

ABSTANDSKREUZE

wieder verwendbar

100x

Nr.	Spezifikation	St.	
37195	1,0 mm	100	12
37196	1,5 mm	100	12
37197	2 mm	100	12
37198	3 mm	100	12

FESTA

FLIESENKREUZE

Nr.	Spezifikation	St.	
37148	1,0 mm	200	100
37149	1,5 mm	200	100
37150	2 mm	200	100
37151	2,5 mm	200	100
37152	3 mm	150	100
37153	4 mm	100	100
37154	5 mm	75	100
37158	10 mm	30	100



FESTA

FLIESENABSTANDSHALTER

100x

Nr.	Spezifikation	
37285	1,5 mm	100
37286	2 mm	100
37287	2,5 mm	100
37288	3 mm	100
37289	4 mm	100



NEW

horizontale Position
110 kg

Ø 220 mm

vertikale Position
80 kg

USB-C



FESTA
POWER X TOOLS

SAUGNAPF AKU

Ø 220 mm	80kg	110kg	ROUGH SURFACE	USB-C	Li-ion 3.6V 2Ah
----------	------	-------	---------------	-------	--------------------

Nr. Spezifikation
36326



FESTA

VAKUUM SAUGHEBER MIT MANOMETER

Ø 200 mm	140kg	100kg	ROUGH SURFACE
----------	-------	-------	---------------

Nr. Spezifikation
36325

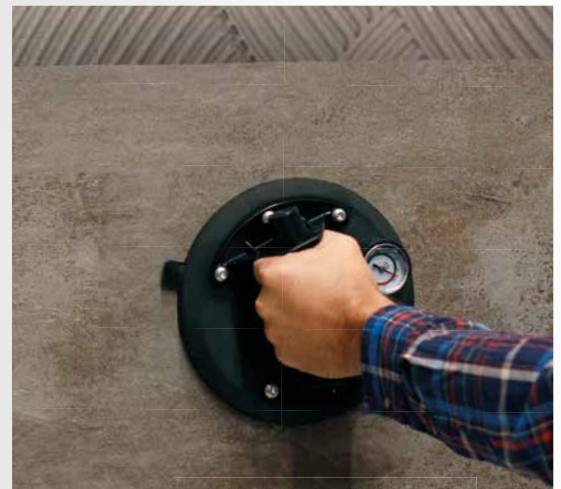

FESTA

GLASERHALTER

Stellung	max. Tragfähigkeit:
horizontale Position	120 kg
vertikale Position	150 kg

ALU

Nr.	Spezifikation	
36318	dreifach	10



GLASERHALTER

Nr.	Spezifikation	
36305	einfach	60

FESTA

GLASERHALTER

Stellung	max. Tragfähigkeit:
horizontale Position	80 kg
vertikale Position	100 kg

ALU

Nr.	Spezifikation	
36313	doppelt	20



GLASERHALTER

Nr.	Spezifikation	
36306	doppelt	20

FESTA

GLASERHALTER

Stellung	max. Tragfähigkeit:
horizontale Position	50 kg
vertikale Position	50 kg

ALU

Nr.	Spezifikation	
36314	einfach	20



GLASERHALTER

Stellung	max. Tragfähigkeit:
horizontale Position	80 kg
vertikale Position	100 kg

ALU

Nr.	Spezifikation	
36319	dreifach	10



**FESTA**

SET TROMMEL 30 M + PUDER 120 G

- 6x schnellerer Wickelmechanismus
- Lotfunktion



Nr.

37070



6

**FESTA**

SET TROMMEL 30 M + PUDER 150 G

- 5x schnellerer Wickelmechanismus



Nr.

37065



6



ABS-AUFWICKLER 30 M + PUDER 180 G



Nr.

37069



10



KUNSTSTOFFAUFWICKLER 30 M



Nr.

37066



25



METALLAUFWICKLER 30 M

ALU

Nr.

37068



25



ABS-AUFWICKLER 30 M



Nr.

37067



25

**FESTA**

PUDER 180 G

Nr.	Spezifikation	
37096	blau	10
37094	hell-blau	10
37097	rot	10
37095	hell-rot	10
37098	schwarz	10

**FESTA**

SCHNUR ROT



Nr.

38895

Spezifikation

50 m



24

38896

100 m

24

**FESTA**

SCHNUR GELB



Nr.

38899

Spezifikation

50 m



24

38900

100 m

24

**FESTA**

POLYETHYLEN MAUERWERST.BAND 50 M



Nr.

38907

Spezifikation

rot 1,0 mm

100

38908

rot 1,7 mm

100

38909

rot 2,0 mm

100



FESTA

POLYETHYLEN
MAUERWERST.BAND 50 M

Nr.	Spezifikation	
38904	gelb, 1,0 mm	100
38905	gelb, 1,7 mm	100
38906	gelb, 2,0 mm	100



FESTA

POLYETHYLEN
MAUERWERST.BAND 50 M

Nr.	Spezifikation	
38910	orange 1,0 mm	100
38911	orange 1,7 mm	100
38912	orange 2,0 mm	100



FESTA

POLYETHYLEN
MAUERWERST.BAND 50 M

Nr.	Spezifikation	
38901	weiß, 1,0 mm	100
38902	weiß, 1,7 mm	100
38903	weiß, 2,0 mm	100



GEWACHSTE SCHNUR



Nr.	Dauer	Ø	
50920	50 m	1 mm	80



FESTA

BLEILOT MIT SCHNUR 15 M

Nr.	Spezifikation	
38916	150 g	10
38917	300 g	6
38918	500 g	5



FESTA

BLEILOT

Nr.	Spezifikation	
38913	150 g	10
38914	300 g	10
38915	500 g	10

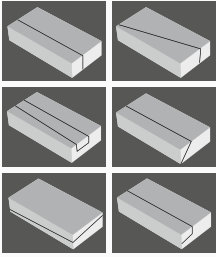

**FESTA****STYROPORDRAHTSCHNEIDER**

- Spannung/Frequenz: 230 V/50 Hz
- Leistungsaufnahme: 200 W
- Schnittlänge: 137 cm
- Schnitthöhe: 30 cm
- Schutzart: IP44
- Schnittwinkel: 0° - 90°

· Ausstattung: Ständer, Fußschalter, Gerüsthalter, 2x Ni-Cr-Schneiddraht, Reinigungs-Messingbürste, Werkzeug und Befestigungsmaterial, Kunststoffbox mit Rädern



Nr. Spezifikation

35348

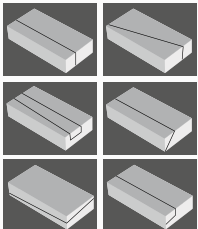

1

**FESTA****STYROPORDRAHTSCHNEIDER**

- Spannung/Frequenz: 230 V / 50 Hz
- Leistungsaufnahme: 200 W
- Schnittlänge: 137 cm
- Schnitthöhe: 30 cm
- Schutzart: IP44
- Schnittwinkel: 0° - 90°



· Ausstattung: Ni-Cr-Schneiddraht, Reinigungsbürste aus Messing, Inbus

Nr. Spezifikation

35345



1

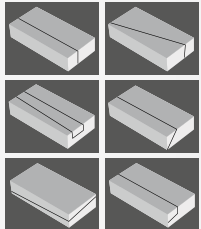
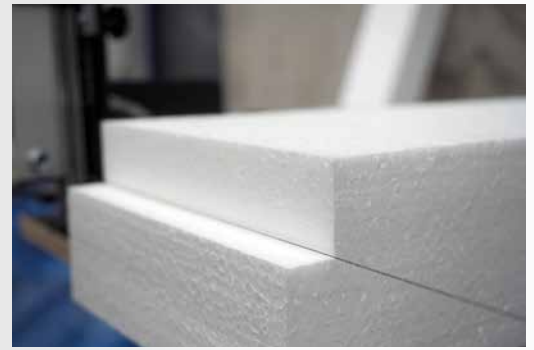

FESTA

STYROPORDRAHTSCHNEIDER

- Spannung/Frequenz: 230 V / 50 Hz
- Leistungsaufnahme: 160 W
- Schnittlänge: 117 cm
- Schnitthöhe: 52 cm
- Schutzart: IP44
- Schnittwinkel: 0° - 90°



· Ausstattung: Ni-Cr-Schneidedraht, Reinigungsbürste aus Messing, Inbus

Nr. Spezifikation
35344



1

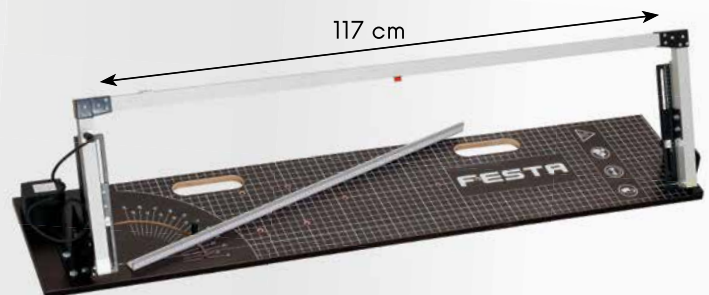
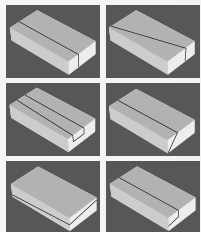

FESTA

STYROPORDRAHTSCHNEIDER

- Spannung/Frequenz: 230 V / 50 Hz
- Leistungsaufnahme: 160 W
- Schnittlänge: 117 cm
- Schnitthöhe: 30 cm
- Schutzart: IP44
- Schnittwinkel: 0° - 90°



· Ausstattung: Ni-Cr-Schneidedraht, Reinigungsbürste aus Messing, Inbus

Nr. Spezifikation
35330



1

**FESTA**

FUSSSCHALTER FÜR STYROPORSCHNEIDER

für 35330, 35345, 35348

Nr.	Spezifikation
35334	



1

**FESTA**

STAND FÜR STYROPORSCHNEIDER

für 35330, 35345, 35348

Nr.	Spezifikation
35336	



1

**FESTA**

ERSATZFEDER FÜR STYROPORSCHNEIDER

für 35330, 35345, 35348

Nr.	Spezifikation
35332	



1

**FESTA**

ERSATZ TRAFO FÜR STYROPORSCHNEIDER

für 35330, 35345, 35348



Spannung/Frequenz:	230 V / 50Hz
Ausgabe:	36 V / 5 A
Leistungsaufnahme:	200 W

Nr.	Spezifikation
35347	



1

FESTA

GERÜSTHALTER FÜR STYROPORSCHNEIDER

für 35330, 35345, 35348

Nr.	Spezifikation
35333	



1



ERSATZ-SCHNEIDEDRAHT Cr-Ni FÜR STYROPORSCHNEIDER

Nr.	Spezifikation
35331	für Styroporschneider 117 cm
35346	für Styroporschneider 137 cm



1





FESTA

KABELLOSER STYROPORSCHNEIDER

- Akku: 36 V, 1,5Ah Li-ion
- Leistung: 180 W
- Temperatur: max 350 C°
- Klingenlänge: 20 cm
- Ausstattung: 2 Akkus, Ladegerät, Klinge, Messing-Reinigungsbürste, Inbus



Nr.	Spezifikation	
35323	Elektrischer Styroporschneider	1
35328	Ersatzklinge für Styroporschneider 14 cm	1
35329	Ersatzklinge für Styroporschneider 25 cm	1



FESTA

ELEKTRISCHER STYROPORSCHNEIDER

- Spannung / Frequenz: 230 V/50 Hz
- Leistungsaufnahme: 250 W
- Temperatur: 50-600 C°
- Klingenlänge: 25 cm
- Netzleitungslänge: 3 m



· Ausrüstung: Reinigungsbürste aus Messing, Inbus, Messer 25 cm, Koffer

Nr.	Spezifikation	
35326	Elektrischer Styroporschneider	1
35328	Ersatzklinge für Styroporschneider 14 cm	1
35329	Ersatzklinge für Styroporschneider 25 cm	1



FÜHRUNGSSCHIENE FÜR STYROPORSCHNEIDER für 35323, 35326



Nr.	Spezifikation	
35327	Führungsschiene	1
35335	Ersatzmesser - 30 cm	1

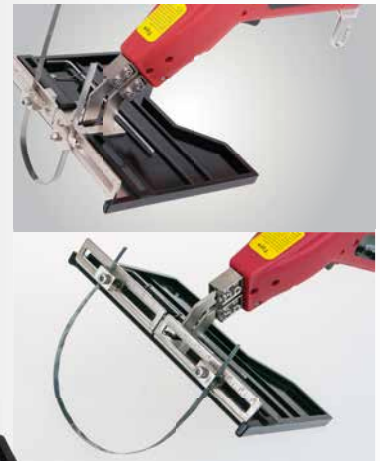

FESTA

ELEKTRISCHER STYROPORSCHNEIDER



· Temperaturregelung

Nr.	Spezifikation	
35325	220 W	1



FESTA

POLYSTYROL-FRÄSMASCHINE

ALU

Nr.	Spezifikation	
24752	Ø 65 mm	1
24753	Ø 70 mm	1

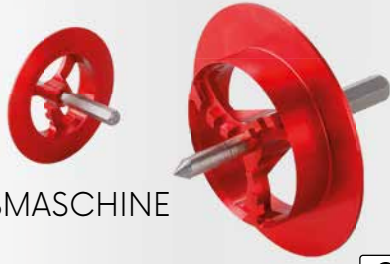

POLYSTYROL-FRÄSMASCHINE

Nr.	Spezifikation	
24727	Ø 65 mm	1
24729	Ø 68 mm	1
24728	Ø 70 mm	1



FASSADENDÜBEL

100x

MADE IN EU

Nr.	Spezifikation		Nr.	Spezifikation	
39210	Ø 10 x 100 mm	1	39218	Ø 10 x 180 mm	1
39212	Ø 10 x 120 mm	1	39217	Ø 10 x 200 mm	1
39214	Ø 10 x 140 mm	1	39219	Ø 10 x 220 mm	1
39216	Ø 10 x 160 mm	1			

**FESTA**

DÜBEL IN DIE DÄMMUNG Z LEITSPINDELHÜLSEN

2x

Nr.	Spezifikation	
39240	weiß M10	1
39241	grau M10	1
39242	Anthrazit M10	1
39243	braun M10	1
39244	schwarz M10	1



WÄRMEDÄMMUNTERLAGE

für Schrauben Ø 6 und 8 mm

50x

Nr.	Spezifikation	
39208	Ø 68 mm	1

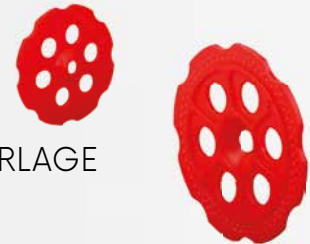

WÄRMEDÄMMUNTERLAGE

Nr.	Spezifikation	
39206	Ø 40 mm	200
39207	Ø 60 mm	100

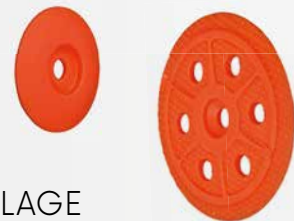

MOQ

NIVELLIERWALZE

MADE IN EU

Nr.	Durchmesser	Spitzenhöhe	Dauer	
38950	Ø 69 mm	12 mm	25 cm	10
38951	Ø 69 mm	12 mm	40 cm	8
38952	Ø 122 mm	34 mm	25 mm	10
38953	Ø 122 mm	34 mm	40 cm	8
38954	Ø 122 mm	34 mm	60 mm	4

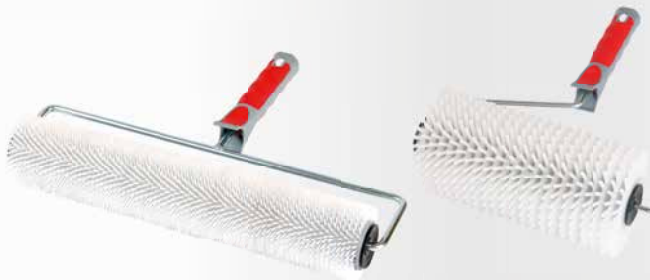

SOHLEN MIT SPIKES PAAR

MADE IN EU

Nr.	Spezifikation	
38970	Spitzen 25 mm	1
38971	Spitzen 30 mm	1





RABITZUNTERLAGE



Nr.	Spezifikation	
42420	Ø 30 mm	1



RABITZGEFLECHT



Nr.	Spezifikation	
42312	1 m 50 bm 16 x 16 mm	1

PUTZLEISTE AUS HOLZ



Nr.	Dauer	Stärke	Breite	
37120	200 mm	1,7 mm	20 mm	10
37119	250 mm	1,7 mm	20 mm	10



SIEB FÜR STUCK



Nr.	Breite	Hohe	Gittergewebe	
37216	50 mm	50 mm	2 mm	1
37217	50 mm	50 mm	3 mm	1
37218	50 mm	50 mm	4 mm	1

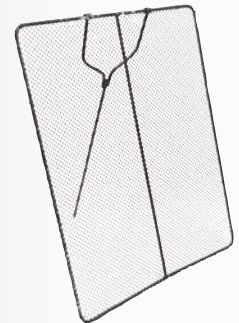

WURFSIEB

Nr.	Breite	Hohe	Gittergewebe	
37236	0,8 m	1 m	10 mm	1
37237	0,8 m	1 m	12 mm	1
37238	0,8 m	1 m	16 mm	1
37239	0,8 m	1 m	20 mm	1



BEWEHRUNGSFASER FÜR BETON 0,9 KG

· +/- 150 g / 50 kg Zement
- 600 - 900 g/m² Beton oder Mörtel



Nr.	Gewicht	
42115	0,9 kg	9



NETZ FÜR GERÜSTE

Nr.	Spezifikation	
42120	2,5 x 20 m, 80 g/m ² grün	5



VERPUTZMASCHINE



Nr.	
37114	1



VERPUTZMASCHINE



Nr.	Spezifikation	
37115		1



VERZINKTE MAURERKLAMMER

Zn			
Nr.	Spezifikation		
37231	14 cm frei	10	MOQ 10



GESCHMIEDETE MAUERWERKSKLEMME

Nr.	Spezifikation		
37232	14,5 cm	5	MOQ 5



MAURERKLAMMER SET

Nr.	Spezifikation		
37230	16 cm	6	6x

VERZINKTER KLAMMER

Zn			
Nr.	Spezifikation		
37233	320 x 10 mm	100	
37234	320 x 12 mm	100	

KLAMMER

Nr.	Spezifikation		
37235	250 x 12 mm	1	

ALUMINIUM-ECKE

ALU			
Nr.	Spezifikation		
39245	AL 30 m x 5 cm	1	

KUNSTSTOFFECKE

Nr.	Spezifikation		
39238	3 m	25	MADE IN EU

SPACHTEL FÜR GIPSKARTONMACHER

PLASTIC			
Nr.	Spezifikation		
34308	50 mm	20	
34307	80 mm	12	
34306	100 mm	10	
34305	150 mm	12	

GIPSKARTON-PLATTEN HEBER

· Hub 153 - 344 cm
· Höchstlast 54 kg

Nr.	Spezifikation		
26775		1	

GIPSKARTONMACHER SET

Nr.	Spezifikation		
34300	Set 9 St.	10	
34303	Becken	60	

FESTA

PLATTENTRÄGER

2x			
Nr.	Spezifikation		
36312	Becken	12	

FESTA

PLATTEN-TRÄGER

Nr.	Spezifikation		
36308	36 x 16,5 x 7,5 cm	10	



GIPSKARTONRASPEL



Nr.	Spezifikation	
22120	250 x 40 mm	10



GIPSKARTONRASPEL



Nr.	Spezifikation	
22121	250 x 40 mm	10
22122	140 x 40 mm	6



GIPSKARTONRASPEL



Nr.	Spezifikation	
22126	155 x 40 mm	1



GIPSKARTONRASPEL



Nr.	Spezifikation	
22125	Ø 250 x 40 mm	6



GIPSKARTONRASPEL



Nr.	Spezifikation	
22124	Ø 250 x 16 mm	10



GIPSKARTONRASPEL



Nr.	Spezifikation	
22123	60 x 40 mm	6

FESTA

GIPSKARTONSÄGE



Nr.	Spezifikation	
24159	150 mm	12

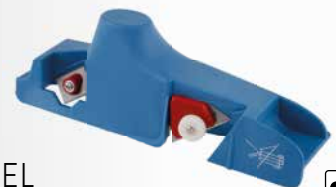

HOBEL FÜR GIPSKARTON



Nr.	Spezifikation	
34315		10
34316	náhradní břit	1



GIPSKARTON-BOHRSÄGE



Nr.	Spezifikation	
24190	300 mm	10

ERSATZRASPEL

Nr.	Spezifikation	
22130	250 x 40 mm	20
22129	155 x 40 mm	20
22132	140 x 40 mm	20
22133	60 x 40 mm	20
22134	Ø 16 x 250 mm	20



FESTA**PB-BRENNER - SATZ**

Ø 17, 22, 40 mm



Nr.	Spezifikation	
69918	2 kW, 3 m Schlauch	10

**FESTA****PB-BRENNER - SATZ**

Ø 25, 35, 50 mm



Nr.	Spezifikation	
69919	19,5 kW, 1,5 m Schlauch	10

**FESTA****PB-BRENNER**

Nr.	Spezifikation	
69900	Ø 35 mm, Länge 300 mm, ohne Schlauch	10
69901	Ø 35 mm, Länge 300 mm + 3 m Schlauch	5

**FESTA****LÖTSET 3 KW**

Nr.	Spezifikation	
69914	300 mm + 2 m Schläuche	5

**FESTA****PB-BRENNER**

Nr.	Spezifikation	
69902	Ø 55 mm, Länge 550 mm, ohne Schlauch	10

**FESTA****PB-BRENNER**

Nr.	Spezifikation	
69903	Ø 55 mm, Länge 550 mm + 3 m Schlauch	10

**FESTA****PB-BRENNER**

Nr.	Spezifikation	
69905	Ø 55 mm, Länge 900 mm, ohne Schlauch	10

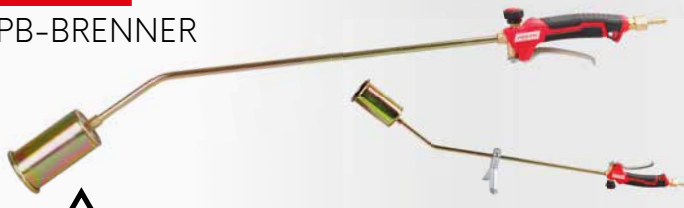
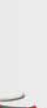
**FESTA****PB-BRENNER**

Nr.	Spezifikation	
69906	Ø 55 mm, Länge 900 mm + 3 m Schlauch	5



FESTA

PB-BRENNER - SATZ



· Ø 55 mm



Nr.	Spezifikation	
69904	60 kW, 850 mm, 5 m Schlauch	8

FESTA

PB-BRENNER - SET MIT DRUCKMINDERVENTIL

· Reduzierventil für den Anschluss von 10 und 33 kg -Flaschen



Nr.	Spezifikation	
69917	Ø 60 mm, Länge 900 mm + 3 m Schlauch 3 m	1

FESTA

SCHLAUCH FÜR PB-BRENNER



Nr.	Spezifikation	
69910	3 m mit Endungen	20
69911	5 m mit Endungen	12
69912	10 m mit Endungen	8



PROPAN-BUTAN-DRUCKMINDERVENTIL

Vordruck	25 bar
Ausgangsdruck:	0,5 - 4,0 bar
Nennvolumenstrom	16 kg h
Eingangsanschluss	W 21,8 x 1 14" LH
Ausgangsanschluss	G3 8" LH

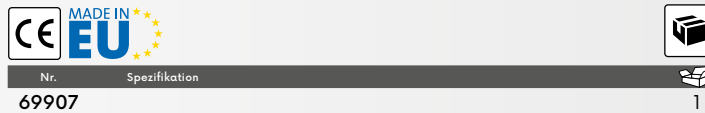

Nr.	Spezifikation	
69907		1

PROPAN-BUTAN-DRUCKMINDERVENTIL

Ausgangsdruck:	4,0 bar
Nennvolumenstrom	16 kg h
Eingangsanschluss	W 21,8 x 1 14" LH
Ausgangsanschluss	G3 8" LH

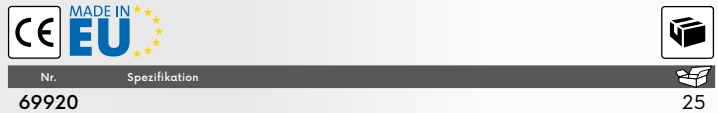

Nr.	Spezifikation	
69920		25

PROPAN-BUTAN DRUCKMINDERVENTIL

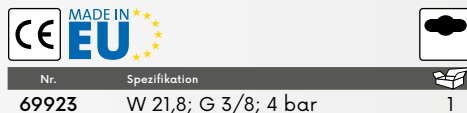

Nr.	Spezifikation	
69923	W 21,8; G 3/8; 4 bar	1

DRUCKREGLER

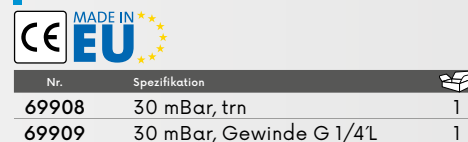

Nr.	Spezifikation	
69908	30 mBar, trn	1
69909	30 mBar, Gewinde G 1/4L	1

EINWEG-ABSPERRVENTIL

· Auslass G 3/8L, für 2 kg PB Flasche

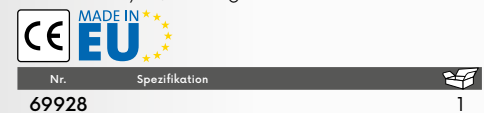

Nr.	Spezifikation	
69928		1

**FESTA****GASBRENNER AUF GEWINDEKARTUSCHE**

· max. Temperatur: 1200 °C
 · Leistung: 1,7 kW
 · Brennerdurchmesser: Ø 20 mm



Nr.	Spezifikation
69930	piezo

20

**FESTA****GASBRENNER FÜR EINSTECHPATRONE**

· max. Temperatur: 1200 °C
 · Leistung: 1,7 kW
 · Brennerdurchmesser: Ø 20 mm



Nr.	Spezifikation
69931	piezo

12

**GIPSSCHALE**

Nr.	Spezifikation
37121	kónická



1

**GIPSSCHALE**

Nr.	Spezifikation
37122	nízka



1

**GIPSSCHALE**

MADE IN EU

Nr.	Spezifikation
33275	niedrig aus Gummi



20

**EIMER VERZINKT**

Zn	
Nr.	Spezifikation
39000	5 l
39001	10 l
39002	12 l
39003	15 l



40

30

20

20

**MAUREREIMER**

MADE IN EU

Nr.	Spezifikation
39005	5 l
39010	10 l
39012	12 l
39014	15 l mit Trichter
39020	20 l
39021	20 l mit Trichter



1

1

1

1

1

1

**KUNSTSTOFFBEHÄLTER - FLEXIBEL**

MADE IN EU

Nr.	Spezifikation
39192	30 l
39193	45 l



20

20

RUNDES MAURERGEFÄSS

MADE IN EU

Nr.	Spezifikation
39045	45 l Ø 54 x 27 cm
39065	60 l Ø 60 x 35 cm
39090	90 l Ø 66 x 35 cm



1

1

1

**RECHTECKIGES MAURERGEFÄSS**

MADE IN EU

Nr.	Spezifikation
39145	40 l 71 x 40 x 21 cm
39165	65 l 71 x 40 x 30 cm
39190	85 l 77 x 48 x 30 cm



1

1

1



FESTA

- schlagfester Griff
Nylon + Fiberglas



- 360° drehbarer Kopf



- 3-Positionen-Anti-Spill-Schalter



- Dosierungsumschaltung
9:1 / 18:1



FESTA

SILIKONPISTOLE
MIT
ANTI-TROPF

Nr. Spezifikation
38027

1

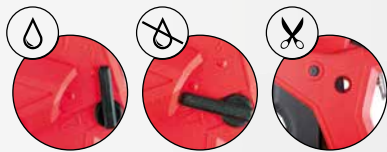

NEW



FESTA

SILIKONPISTOLE
MIT
ANTI-TROPF

Č.p. Spezifikace
38032 nylonová



24



FESTA

SILIKONPISTOLE
MIT
ANTI-TROPF

Nr. Spezifikation
38028

1



FESTA

EXTRUSIONS-
PISTOLE
VERSTÄRKT

Nr. Spezifikation
38013

12



FESTA

EXTRUSIONS-
PISTOLE

Nr. Spezifikation
38001

24



FESTA

EXTRUSIONS-
PISTOLE

Nr. Spezifikation
38012

6



FESTA

EXTRUSIONS-
PISTOLE

Nr. Spezifikation
38024

1



EXTRUSIONS-
PISTOLE
MIT RÜCST.
TOSS



Nr.	Spezifikation	
38010	6-Kant	24

EXTRUSIONS-
PISTOLE



Nr.	Spezifikation	
38025		24

FESTA

EXTRUSIONS-
PISTOLE FÜR
CHEMISCHE
DÜBEL 380 ML



Nr.	Spezifikation	
38020		12

EXTRUSIONS-
PISTOLE -
GESTUFT



Nr.	Spezifikation	
38006		12

EXTRUSIONS-
PISTOLE



Nr.	Spezifikation	
38002	6-Kant	24

EXTRUSIONS-
PISTOLE
KUNSTSTOFF



Nr.	Spezifikation	
38003	6-Kant	24

EXTRUSIONS-
PISTOLE



Nr.	Spezifikation	
38007		24

EXTRUSIONS-
PISTOLE
HALBGE-
SCHLOSSEN



Nr.	Spezifikation	
38008		24

GEZAHNTE
EXTRUSIONS-
PISTOLE



Nr.	Spezifikation	
38009		24

EXTRUSIONS-
PISTOLE



Nr.	Spezifikation	
38000		24

FESTA

EXTRUSIONSPISTOLE



ALU

Nr.	Spezifikation	
38005	310 ml	20
38014	Spitze 3 St.	100

FESTA

EXTRUSIONSPISTOLE



ALU

Nr.	Spezifikation	
38004	600 ml	12
38014	Spitze 3 St.	100

FESTA

PU-SCHAUM-PISTOLE
MIT TEFLON-
OBERFLÄCHE



TEFLON

Nr.	Spezifikation	
38018		20

FESTA

PU-SCHAUM-PISTOLE
MIT TEFLON-
OBERFLÄCHE



TEFLON

Nr.	Spezifikation	
38017		20

FESTA

PISTOLE FÜR
PU-SCHÄUME



TEFLON

TEFLON

Nr.	Spezifikation	
38016		20

FESTA

PISTOLE FÜR
PU-SCHÄUME



TEFLON

TEFLON

Nr.	Spezifikation	
38015		20

PISTOLE FÜR
PU-SCHÄUME



Nr.	Spezifikation	
38031		20

FESTA

PISTOLE FÜR
PU-SCHÄUME
ABS



Nr.	Spezifikation	
38022	ABS	20

PISTOLE FÜR
PU-SCHÄUME



Nr.	Spezifikation	
38021		24

ERSATZDÜSE
FÜR PISTOLEN

· für Pistole 38015, 38016, 38017, 38018



Nr.	Spezifikation	
38030		5



FLACHPINSEL NATUR

Nr.	Breite	Stärke	Dauer	
52212	20 mm	15 mm	40 mm	12
52213	30 mm	15 mm	45 mm	12
52214	40 mm	15 mm	45 mm	12
52215	50 mm	15 mm	50 mm	12
52216	60 mm	15 mm	60 mm	12
52217	70 mm	15 mm	65 mm	12
52218	80 mm	15 mm	65 mm	12
52220	100 mm	15 mm	70 mm	12



FLACHPINSEL

Nr.	Breite	Stärke	Dauer	
52202	20 mm	12,5 mm	38 mm	12
52203	30 mm	13 mm	38 mm	12
52204	40 mm	14 mm	44 mm	12
52205	50 mm	16 mm	44 mm	12
52206	60 mm	17 mm	52 mm	12
52208	80 mm	17 mm	52 mm	12
52207	100 mm	18 mm	52 mm	12



ECKENPINSEL

Nr.	Breite	Stärke	Dauer	
52283	25 mm	10 mm	44 mm	12
52284	38 mm	10 mm	44 mm	12
52285	50 mm	10 mm	44 mm	12
52286	62 mm	10 mm	50 mm	12
52288	76 mm	10 mm	50 mm	12



PINSELSET KUNSTSTOFFGRIFF

3x

Nr.	Spezifikation	
52070	20, 30, 50 mm	50



PROFI-STREICHBÜRSTE



Nr.	Spezifikation	
52075	Ø 90 mm	10



PROFI-STREICHBÜRSTE



Nr.	Breite	Dauer	
52076	170 mm	80 mm	10



PINSELSET KUNSTSTOFFGRIFF

5x

Nr.	Spezifikation	
52071	15 mm, 25 mm, 40 mm, 60 mm, 80 mm	50



STREICHBÜRSTE

Nr.	Breite	Dauer	
52077	Ø 105 mm	70 mm	12



STREICHBÜRSTE

Nr.	Breite	Dauer	
52078	170 mm	70 mm	12

TABELLE ZUR VERWENDUNG VON FARBWALZEN

FARBEN UND LACKE

MATERIAL	FLORHÖHE MM	FARBEN UND LACKE												
		DISERSIONS-	ROSTSCHUTZ-	HARZ-	ÖL-	WASSERBA-SIERTE	POLYESTER-HALTIGE	BINDEMittel-	LASUREN	LATEX-	EPOXY-	2-KOMPO-NENTNI	DICKFLÜSSIGE	ACRYL-
PES	20	•						•		•			•	
PES	20	•	•			•		•		•				•
PAC	18	•						•		•				
PAC	12, 13	•								•				
PAD	18, 21	•								•				
PAD	13	•	•							•				
LAMMFELL	23	•								•				
NYLON	13		•	•	•	•	•			•	•	•		
VELOUR	4		•	•		•				•	•	•		
MICROFIBRE	10					•			•	•				
SCHAUMSTOFF				•		•								•

POLYACRYL-WALZE

PAC

MADE IN EU

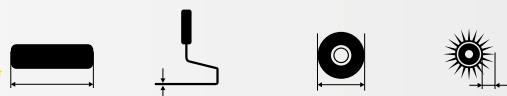

Nr.						
52331	100 mm	Ø 6 mm	Ø 17 mm	12 mm	50	
52334	250 mm	Ø 8 mm	Ø 48 mm	12 mm	10	

POLYACRYL-WALZE

PAC

MADE IN EU



Nr.						
52391	polster 5	250 mm	Ø 8 mm	Ø 54 mm	18 mm	10

POLYACRYL-WALZE

PAC

MADE IN EU



Nr.						
52328	polster 5	250 mm	Ø 8 mm	Ø 54 mm	18 mm	10
52456	polster 7	250 mm	Ø 8 mm	Ø 67 mm	18 mm	10

POLYAMID-WALZE

PAD

MADE IN EU



Nr.						
52428	polster 7	250 mm	Ø 8 mm	Ø 67 mm	18 mm	10

NYLON-LASURWALZE

PAD

MADE IN EU



Nr.						
52421	100 mm	Ø 6 mm	Ø 17 mm	13 mm	50	
52424	250 mm	Ø 8 mm	Ø 48 mm	13 mm	10	

POLYESTERWALZE

PES

MADE IN EU



Nr.						
52305	180 mm	Ø 6 mm	Ø 42 mm	20 mm	10	
52306	250 mm	Ø 6 mm	Ø 42 mm	20 mm	10	

SCHAUMSTOFF-FARBROLLER

MADE IN EU

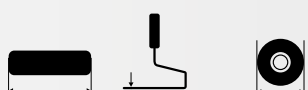

Nr.						
52471	gerade	100 mm	Ø 6 mm	Ø 35 mm	50	



PENETRATIONSKIT



PAC
MADE IN EU

Nr.	polster 4	180 mm	Ø 8 mm	Ø 53 mm	18 mm	1
52600						

MALSET - VESTAN



PES
MADE IN EU

Nr.	52610	180 mm	Ø 6 mm	Ø 42 mm	20 mm	25
52605		250 mm	Ø 6 mm	Ø 42 mm	20 mm	20

LACKIER-SET

- 1x Walze PAD 13mm/ 10 cm
- 1x Walze PAC 12mm/ 10 cm
- 1x Walze PES 11mm/ 10 cm
- Halter
- Schale



MADE IN EU

Nr.	52602	10
52602		

POLYACRYL ECKWALZE

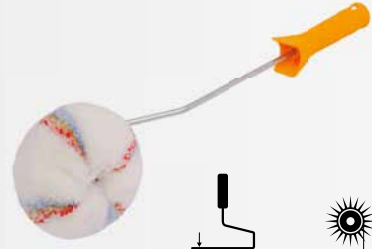

PAC
MADE IN EU

Nr.	52601	inkl. Halter	Ø 6 mm	18 mm	1
52601					

SCHALE



MADE IN EU

Nr.	Spezifikation		
52662	150 x 270 mm	100 mm	1
52666	260 x 290 mm	180 mm	1
52671	330 x 340 mm	250 mm	1

FARBEIMER



MADE IN EU

Nr.	Volumen	
52694	8 l	25
52695	12 l	20

GITTER



MADE IN EU

Nr.	Breite	Hohe	
52652	230 mm	250 mm	100
52656	270 mm	290 mm	100



HALTER



MADE IN EU

Nr.	Spezifikation	
52640	5 cm Ø 6 mm	100
52645	8,5 cm Ø 6 mm x 27 mm	100

HALTER



MADE IN EU

Nr.	Spezifikation	
52630	18 cm Ø 6 mm	100
52635	25 cm Ø 6 mm	100
52620	18 cm Ø 8 mm	50
52625	25 cm Ø 8 mm	50

SCHABER FÜR FARBEN UND LACKE



Nr.	37005	12
37005		

FESTA

TELESKOPSTANGE

Gewinde für 31610, 34203

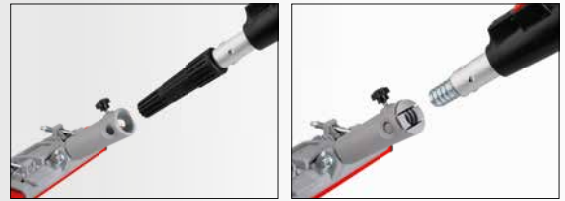

Nr.	Spezifikation	
52011	88 - 140 cm	1



TELESKOPSTANGE

ALU

Nr.	Dauer		
52010	120 cm	ALU	50
52012	240 cm	ALU	25



TELESKOPSTANGE

Nr.	Dauer		
52020	300 cm	Stahl	10



TELESKOPSTANGE

Nr.	Dauer		
52030	240 cm	fiberglass	6



SELBSTKLEBENDES ABDECKBAND MIT FOLIE

Nr.	Breite	Dauer	
37243	55 cm	30 m	60
37244	110 cm	30 m	30
37245	140 cm	30 m	30
37246	180 cm	15 m	30
37290	210 cm	20 m	30
37247	240 cm	15 m	30
37291	270 cm	16 m	30



SCHUTZANZUG MIT KAPUZE

Nr.	Spezifikation	
50585	Größe M	1
50586	Größe L	1
50587	Größe XL	1
50588	Größe XXL	1



TÜR FOLIE MIT REISSVERSCHLUSS

Nr.	Spezifikation	
37248	1,2 x 2,2 m Band 100 µm 45 mm x 25 m	25



UNIVERSALE ABDECKFOLIE

Nr.	Volumen	Werkstoffdicke	
37250	4 x 5 m	0,007 mm	100
37251	4 x 12,5 m	0,007 mm	50
37252	2 x 50 m	0,007 role	20



UNIVERSALE ABDECKFOLIE

Nr.	Spezifikation	Werkstoffdicke	
37253	4 x 5 m	0,03 mm	100

WELLPAPPE



Nr.	Breite	Dauer	
54008	1 m	10 m	1



FESTA



PROFI
PE-PLANE

blau-silber

140 g/m²



Nr.	Spezifikation	
25206	2 x 3 m	25
25212	3 x 4 m	10
25215	3 x 5 m	8
25220	4 x 5 m	8
25224	4 x 6 m	8
25230	5 x 6 m	8

Nr.	Spezifikation	
25240	5 x 8 m	4
25248	6 x 8 m	3
25260	6 x 10 m	3
25296	8 x 12 m	2
25350	10 x 15 m	1



ABDECKPLANE
EKONOMIK

blau



Nr.	Spezifikation	
25369	2 x 2 m	50
25370	2 x 3 m	20
25371	3 x 4 m	10
25372	3 x 5 m	10
25373	4 x 5 m	10

Nr.	Spezifikation	
25374	4 x 6 m	5
25376	5 x 8 m	5
25378	6 x 10 m	2
25379	8 x 12 m	2
25380	10 x 15 m	2

STANDARD
ABDECKPLANE

blau-silber

70 g/m²



Nr.	Spezifikation	
25155	2 x 2 m	50
25006	2 x 3 m	50
25009	3 x 3 m	35
25012	3 x 4 m	20
25015	3 x 5 m	10
25016	4 x 4 m	10
25020	4 x 5 m	10
25024	4 x 6 m	10

Nr.	Spezifikation	
25025	5 x 5 m	10
25030	5 x 6 m	10
25040	5 x 8 m	5
25048	6 x 8 m	5
25060	6 x 10 m	5
25096	8 x 12 m	2
25150	10 x 15 m	2
25153	15 x 20 m	1

STANDARD
ABDECKPLANE

grün

70 g/m²



Nr.	Spezifikation	
25179	2 x 2 m	50
25180	2 x 3 m	50
25195	2 x 8 m	20
25181	3 x 4 m	20
25182	3 x 5 m	10
25183	4 x 5 m	10

Nr.	Spezifikation	
25184	4 x 6 m	10
25186	5 x 8 m	5
25188	6 x 10 m	5
25189	8 x 12 m	2
25190	10 x 15 m	2

PROFI
PE-PLANE

grün-grün

200 g/m²



Nr.	Spezifikation	
25160	2 x 3 m	15
25171	2 x 8 m	1
25162	3 x 5 m	5
25163	4 x 5 m	4

Nr.	Spezifikation	
25164	4 x 6 m	3
25167	6 x 8 m	2
25169	8 x 12 m	1
25170	10 x 15 m	1

PE-PLANE
RUND

blau-silber

120 g/m²



Nr.	Spezifikation	
25003	Ø 3,6 m	15
25004	Ø 4,5 m	5
25005	Ø 5,5 m	4
25002	Ø 6,5 m	3



PLANESPANNER

Nr.	Spezifikation	
25400	20 cm	1

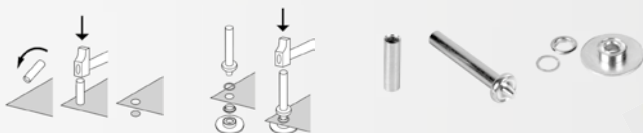

ÖSENAPPLIKATOR FÜR PLANEN

Nr.	Spezifikation	
25410	Ösenapplikator + 25 Ösen	1



ÖSEN FÜR
PE-PLANEN

Nr.	Spezifikation	
25001		1





TELESKOPLEITER

· max. Tragkraft 150 kg



Nr.	Spezifikation	
48415	1,9 / 3,8 m	6/12 Sprossen 1

TELESKOPLEITER, FALTBAR

· max. Tragkraft 150 kg



Nr.	Spezifikation	
48410	3,2 m	11 Sprossen 1
48411	3,8 m	13 Sprossen 1

KLAPPBARE ARBEITSBÜHNE

· max. Tragkraft 150 kg



Nr.	Spezifikation	
48420		1



NEW

2.75m	H L	H L	1.73m	0.93m	0.99m
	1.60m 1.14m	1.69m 1.32m			



KLEINGERÜST



· max 150 kg

Nr.	Spezifikation	
37660		1



GERÜSTBOCK



Nr.	Spezifikation	
37545	140 cm, Höhe 98 - 165 cm	1
37546	120 cm, Höhe 98 - 165 cm	1



SCHALUNGSSTREBE

- 48449 Käfig für Schalungsstreben



Nr.	Spezifikation	
48452	160 - 290 cm	1
48453	180 - 320 cm	1
48454	200 - 360 cm	1
48455	250 - 440 cm	1
48456	260 - 380 cm	1
48457	220 - 400 cm	1

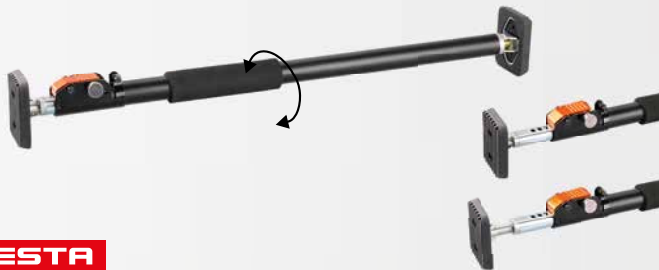

FESTA

SPREIZSTANGE, STÜTZSTANGE

max. Tragfähigkeit 40 kg

Nr.	Spezifikation		
52060	66 - 115 cm	1	
52065	160 - 290 cm	1	



SPREIZSTANGE, STÜTZSTANGE

Nr.	Spezifikation		
52050	50 - 115 cm	1	
52055	115 - 290 cm	1	

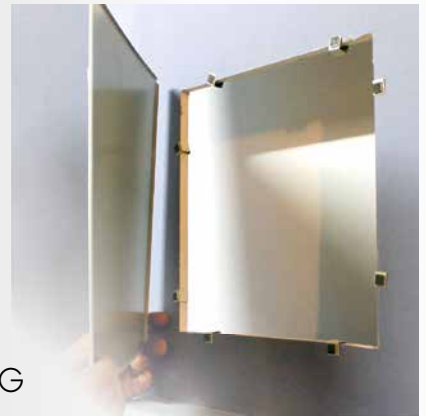

MAGNETISCHE LOCHABDECKUNG

	Nr.	Spezifikation	
	82100	10 - 21 cm	1
	82101	20 - 31 cm	1
	82102	30 - 41 cm	1
	82103	40 - 51 cm	1
	82104	50 - 58 cm	1



BLECHSCHORNSTEINTÜR



Nr.	Spezifikation	
65062		1

COMAX SCHORNSTEINTÜR



Nr.	Spezifikation	
65063	grau	1
65064	weiß	1

VERZINKTE SCHORNSTEINTÜR



Nr.	Spezifikation	
65065		1

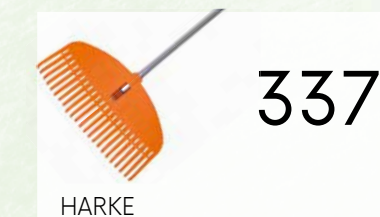



ENWERKZEUG UND
GEFLECHT

308 - 359





GARTENSCHEREN



Ø max. 20 mm SK5



Nr.	Spezifikation	Icon
45020	205 mm	10
44980	Ersatzfeder	1



GARTENSCHEREN



Ø max. 6 mm SK5



Nr.	Spezifikation	Icon
45023	205 mm	10
44980	Ersatzfeder	1



GARTENSCHEREN



Ø max. 20 mm SK5



Nr.	Spezifikation	Icon
45063	215 mm	10
44981	Ersatzfeder	1



GARTENSCHEREN



Ø max. 20 mm SK5 TEFLON



Nr.	Spezifikation	Icon
44972	215 mm	10
44981	Ersatzfeder	1



GARTENSCHEREN



Ø max. 18 mm SK5



Nr.	Spezifikation	Icon
45099	190 mm	10
44983	Ersatzfeder	1



GARTENSCHEREN



Ø max. 20 mm SK5



Nr.	Spezifikation	Icon
45098	220 mm	10
44983	Ersatzfeder	1



GARTENSCHEREN



Ø max. 24 mm SK5 TEFLON



Nr.	Spezifikation	Icon
45095	200 mm	10
44982	Ersatzfeder	1



GARTENSCHEREN



· otočná rukojeť

Ø max. 24 mm SK5 TEFLON



Nr.	Spezifikation	Icon
45096	220 mm	6
44982	Ersatzfeder	1



GARTENSCHEREN



INOX max. mm INOX

Nr.	Spezifikation	
45089	160 mm	10



GARTENSCHEREN



SK5 TEFLON SK5 TEFLON

Nr.	Spezifikation	
45097	210 mm	10
44981	Ersatzfeder	1



GARTENSCHEREN



INOX max. 10 mm

Nr.	Spezifikation	
45088	160 mm	10



max. 12 mm

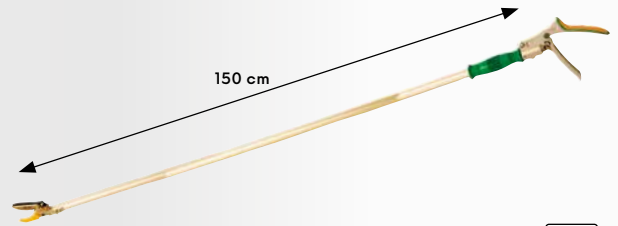

GARTENSCHERE, VERLÄNGERT

Nr.	Spezifikation	
45017		10



ERSATZFEDER



Nr.	für Schere	
44981	45021, 45025, 45063, 45097	1
44980	45020, 45023	1
44983	45098, 45099	1
44982	45027, 45095, 45096	1
44984	45110, 45014, 45026	1
44985	45018	1



ERSATZKLINGE



für Schere 45095, 45027

Nr.	Spezifikation	
45094		20



ASTSCHERE



max. 45mm SK5 TEFLON

Nr.	Spezifikation	
44991	76 cm	12



TELESKOPISCHE ASTSCHERE



max. 45mm SK5 TEFLON

Nr.	Spezifikation	
44992	70 - 103 cm	10



SCHERE



Nr.	Spezifikation	
44996	61 cm, gewellte Klinge	12



SCHERE



Nr.	Spezifikation	
44997	61 cm, gerade Klinge	12



DREHBARE GRASSCHERE 360°



Nr.	Spezifikation	
44998		6



SCHERE- UND MESSERSCHÄRFER 6 IN 1



Nr.	Spezifikation	
45068		10



SCHERE- UND MESSERSCHÄRFER



Nr.	Spezifikation	
45048		20

FESTA

GARTENSCHERE

Nylon-Griff



Nr.	Spezifikation	
45021	210 mm	6

GARTENSCHERE



Nr.	Spezifikation	
45019	210 mm	10



SCHERE

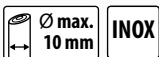

Nr.	Spezifikation	
45010	190 mm	12
44984	Ersatzfeder	1

SCHERE

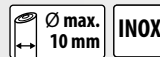

Nr.	Spezifikation	
45014	190 mm	12
44984	Ersatzfeder	1

SCHERE



Nr.	Spezifikation	
45026	150 mm	12
44985	Ersatzfeder	1

GARTENSCHERE



Nr.	Spezifikation	
45018	210 mm geschmiedet	10

GARTENSCHERE



Ø max. 12 mm ALU

Nr.	Spezifikation	
45025	200 mm	12

GARTENSCHERE



TEFLON max. mm TEFLON

Nr.	Spezifikation	
45027	200 mm	10

GARTENSCHERE



INOX max. mm INOX

Nr.	Spezifikation	
44971	160 mm	10

GARTENSCHERE



Ø max. 6 mm

Nr.	Spezifikation	
45015	190 mm, gerade	12

GRASSCHERE



Nr.	Spezifikation	
45011	300 mm	1

GARTENSCHERE



Ø max. 15 mm INOX

Nr.	Spezifikation	
44970	210 mm	10

GARTENSCHERE



Ø max. 12 mm INOX ALU

Nr.	Spezifikation	
45029	200 mm	24

GARTENSCHERE



Ø max. 10 mm

Nr.	Spezifikation	
45016	180 mm	12

SCHEIDE FÜR GARTENSCHERE



Nr.	Spezifikation	
37317		1

GRASSCHERE, DREHBAR



Nr.	Spezifikation	
45012	370 mm, drehbar 180°	1

ASTSCHERE



nylonová rukojeť
Ø max. 30 mm TEFLON NYLON

Nr.	Spezifikation	
44999	540 mm, abgerundet	12



FESTA

ASTSCHERE



Ø max. 30 mm
TEFLON

Nr.	Spezifikation	
45000	750 mm, abgerundet	6

FESTA

ASTSCHERE



Ø max. 25 mm
TEFLON

Nr.	Spezifikation	
45001	710 mm, abgerundet	6

FESTA

ASTSCHERE



Ø max. 40 mm
TEFLON

Nr.	Spezifikation	
45002	750 mm, Ratsche	12

TELESKOPISCHE
ASTSCHERE



Ø max. 30 mm
TEFLON

Nr.	Spezifikation	
45003	660-900 mm, teleskopisch	6

FESTA

SCHERE



Ø max. 6 mm
TEFLON

Nr.	Spezifikation	
45005	580 230 mm, gewellte Schneide	6

FESTA

SCHERE



Ø max. 6 mm
TEFLON

Nr.	Spezifikation	
45006	580 230 mm, gerade Schneide	6

FESTA

TELESKOPISCHE
SCHERE



Ø max. 6 mm
TEFLON

Nr.	Spezifikation	
45007	670-870 230 mm, gewellte Klinge	6

SCHERE



Ø max. 10 mm
TEFLON
NYLON

Nr.	Spezifikation	
44995	440 160 mm	12

SCHERE



Nr.	Spezifikation	
45009	500 190 mm, gewellte Schneide	6

SCHERE



Nr.	Spezifikation	
45008	500 190 mm, gerade Schneide	6

SICHEL



Nr.	Spezifikation	
45490	450 mm	1



FESTA
MACHETE



TEFLON

Nr.	Spezifikation	
45069	440 mm	6

FESTA
MACHETE



TEFLON

Nr.	Spezifikation	
44950	490 mm	4

MACHETE
AUS
EDELSTAHL

INOX

Nr.	Spezifikation	
45083	430 mm	12
45084	600 mm	6



MACHETE

· Griff aus Eschenholz

Nr.	Spezifikation	
45081	510 mm	36
45082	710 mm	36



FESTA
SCHLUSSSÄGE

· 3 x geschliffene und gehärtete Zähne

Nr.	Spezifikation	
45061	150 mm mit Griffabdeckung	12



FESTA
SCHLUSSSÄGE

· 3 x geschliffene und gehärtete Zähne

Nr.	Spezifikation	
45060	180 mm	6



FESTA
SÄGE MIT GEHÄUSE

· 3 x geschliffene und gehärtete Zähne

Nr.	Spezifikation	
45062	260 mm mit Gehäuse	24



FESTA
ASTSÄGE

· 3 x geschliffene und gehärtete Zähne

Nr.	Spezifikation	
24152	350 mm 7 tpi	12



FESTA
TELESKOPISCHE ASTSÄGE

· 3 x geschliffene und gehärtete Zähne

Nr.	Spezifikation	
45033	230 - 490 mm	1



RAUPENKETTE
MIT SÄGE

Nr.	Spezifikation	
45030	Säge 30 cm	6
45031	Säge 30 cm	6



RAUPENKETTE

Nr.	Spezifikation	
45032	Metall-Raupenkette ohne Säge	6



FESTA



FESTA

AXT

DIN 5131 DIN 7294

· Eschestiel
· Kreisheil

Nr.	Spezifikation		Nr.	Spezifikation	
19380	600 g	1	19384	1400 g	1
19381	800 g	1	19385	1600 g	1
19382	1000 g	1	19387	2000 g	1
19383	1250 g	1			

FESTA

ZIMMERMANN-
AXT

· Eschestiel

Nr.	Spezifikation	
19340	700 g	22



FESTA

SPALTHAMMER

· Eschestiel
· Kreisheil

DIN 5129	Nr.	Spezifikation	
	19389	3000 g	1
	19388	4000 g	1



FESTA

SPALTAXT

· Eschestiel
· Kreisheil

DIN 7294	Nr.	Spezifikation	
	19391	2000 g	1



FESTA

FIBERAXT-AXT

· Fiberglass-Stiel

Č.p.	specifikace	
19326	600 g	6
19328	800 g	24
19330	1000 g	12
19332	1250 g	8
19333	1500 g	6
19335	1600 g	6
19337	2000 g	6



FESTA

FIBERAXT-
SPALTAXT

· Fiberglass-Stiel

Č.p.	specifikace	
19392	1000 g	6



FESTA

CAMP AXT,
FIBERGLASS

· Fiberglass-Stiel

Č.p.	specifikace	
19301	500 g	6



FESTA

FIBERAXT-SPALTAXT

· Fiberglass-Stiel

Nr.	Spezifikation	
19390	2000 g	6





FESTA

SPALTHAMMER, FIBERGLASS

Fiberglass-Stiel

Nr.	Spezifikation	
19370	3000 g	4
19371	4000 g	4



AXTSTIEL, ESCHENHOLZ



Č.p.	specifikace	pro sekeru	
61340	36 cm	19380	10
61341	40 cm	19381, 19340	10
61342	50 cm	19382	10
61343	70 cm	19383, 19384	10
61344	80 cm	19385, 19391	10
61345	90 cm	19387	10
61346	90 cm	19388, 19389	10

AXT

Č.p.	specifikace	
19306	600 g	24
19308	800 g	24
19310	1000 g	24
19312	1250 g	12
19314	1500 g	12



TORSIONSSPALTKEIL

Nr.	Spezifikation	
19397	2000 g 55 x 210 x 45 mm	10
19465	2500 g 65 x 230 x 45 mm	10



ÖFFNUNGSKEIL AUS NYLON



Nr.	Spezifikation	
19462	175 x 65 x 20 mm	1
19463	230 x 70 x 30 mm	1
19464	240 x 75 x 40 mm	1



SPALTKEIL

Nr.	Spezifikation	
19394	1000 g 35 x 180 x 40 mm	6
19395	2000 g 40 x 255 x 55 mm	6
19396	2500 g 40 x 260 x 55 mm	8



SPLITTING MANDREL SDS+

SDS+



Nr.	Spezifikation	
19393	Ø 32 x 132 mm	10
19374	Ø 42 x 145 mm	10



VIERARMIGER SPALTTEIL

Nr.	Spezifikation	
19469	2500 g 165 x 87 mm	10

KLINGE,
BREIT,
EDELSTAHL



Nr.	Spezifikation	
45056	360 mm	12

KLINGE,
SCHMAL,
EDELSTAHL



Nr.	Spezifikation	
45057	360 mm	12

HACKE,
EDELSTAHL



Nr.	Spezifikation	
45058	270 mm	12

UNKRAUTAUSSTECHER
MIT WIEGE
US EDELSTAHL



Nr.	Spezifikation	
45059	360 mm	12

KLINGE,
BREIT,
NYLON



Nr.	Spezifikation	
45065	280 mm	1

KLINGE,
SCHMAL,
NYLON



Nr.	Spezifikation	
45066	310 mm	1

HANDGRUBBER
NYLON



Nr.	Spezifikation	
45067	290 mm	1

WERKZEUGSET



Nr.	Spezifikation	
45035	240 mm	35

FLACHHACKE
MIT STIEL



Nr.	Spezifikation	schaftlänge	
61294	140 mm	27 cm	MOQ 3
61221	handhaben	27 cm	1

HERZHACKE
MIT STIEL



Nr.	Spezifikation	schaftlänge	
61295	140 mm	27 cm	MOQ 3
61221	handhaben	27 cm	1

BLATTHACKE
MIT STIEL



Nr.	Spezifikation	schaftlänge	
61296	175 mm	27 cm	MOQ 3
61221	handhaben	27 cm	1

3-ZINKIGE
KRALLE
MIT STIEL



Nr.	Spezifikation	schaftlänge	
61297		27 cm	MOQ 3
61221	handhaben	27 cm	1



3-IN-1-FALTSCHAUFEL

pouzdro

Nr.	Spezifikation	
61085	410 mm	6



BLUMENZWIEBEL-PFLANZER

INOX

Nr.	Spezifikation	
45040	230 mm	60



SETZHOLZ „T“

Nr.	Spezifikation	
45038	280 mm	60



MESSER FÜR UNKRAUT

Nr.	Spezifikation	
45079	200 mm	1



MESSER FÜR UNKRAUT

Nr.	Spezifikation	
45080	200 mm „L“	1



OBSTPFLÜCKER



Nr.	Spezifikation	
45041		75



OBSTPFLÜCKER

Nr.	Spezifikation	
45039		50
45034	170 - 300 cm, Teleskopstiel	5



UNKRAUTSTECHER

Nr.	Spezifikation	
44955	950 mm	16



KULTIVATOR

Nr.	Spezifikation	
45042	160 x 132 cm	12



KULTIVATOR

Nr.	Spezifikation	
44053		12
61251	160 cm Stiel	1



STREUWAGEN

ABMESSUNGEN	
Höhe	111 cm
Breite	55 cm
Behältervolumen	12 l

Nr.	Spezifikation	
45085	12 l	1

FESTA

SCHÄRFER FÜR MESSER UND SCHERE 16V1



	30° Anvil	
	45° Anvil	
	50° Anvil	
	23° Bypass	
	35° Bypass	
	65° Bypass	
	Deburrr Tool	



Nr.	Spezifikation	
45073		1



MESSER- UND SCHEREN-SCHÄRFER 6 IN 1

Nr.	Spezifikation	
45068		10



MESSER- UND SCHEREN-SCHÄRFER

Nr.	Spezifikation	
45048		20



SENSENSCHLEIFSTEIN

Nr.	Spezifikation	
45046	205 x 15 mm	100



SCHLEIFSTEIN, OVAL

Nr.	Spezifikation	
45370	250 x 33 x 18 mm	20



SCHLEIFSTEIN

Nr.	Spezifikation	
45045	150 x 50 x 30 mm	10



MESSER- UND SCHEREN-SCHÄRFER

Nr.	Spezifikation	
16991		20



MESSER- UND SCHEREN-SCHÄRFER

Nr.	Spezifikation	
16990	Ø 50 mm	50





MÄHSTRANG MIT NYLONKERN



Nr.	Spezifikation		
45530	2 mm x 15 m	■	1
45531	2,4 mm x 15 m	■	1
45532	3 mm x 15 m	■	1
45533	3,15 mm x 15 m	■	1
45534	4 mm x 15 m	■	1



MÄHFADEN



MÄHFADEN

Nr.	Spezifikation		
45520	2 mm x 162 m	●	10
45521	2,4 mm x 112 m	●	10
45528	2,7 mm x 90 m	●	10
45522	3 mm x 72 m	●	10
45525	2 mm x 162 m	★	10
45526	2,4 mm x 112 m	★	10
45529	2,7 mm x 90 m	★	10
45527	3 mm x 72 m	★	10

Nr.	Spezifikation		
45500	1,3 mm x 15 m	●	30
45502	1,3 mm x 15 m	★	30
45503	1,6 mm x 15 m	●	20
45505	1,6 mm x 15 m	★	20
45506	2 mm x 15 m	●	12
45508	2 mm x 15 m	★	12
45517	2 mm x 15 m	■	10
45509	2,4 mm x 15 m	●	12
45511	2,4 mm x 15 m	★	12
45512	2,4 mm x 15 m	■	12
45518	2,4 mm x 15 m	■	10
45523	2,7 mm x 15 m	●	10
45524	2,7 mm x 15 m	★	10
45513	3 mm x 15 m	●	10
45515	3 mm x 15 m	★	10
45516	3 mm x 15 m	■	10
45519	3 mm x 15 m	■	10



VLIESTOFF, WEISS



17 g/m²

Nr.	Spezifikation		
45540	1,6 x 5 m		40
45541	1,6 x 10 m		40
45542	1,6 x 50 m	m in Rolle	1
45543	1,6 x 100 m	m in Rolle	1

MULCHVLIESSTOFF SCHWARZ



50 g/m²

Nr.	Spezifikation		
45550	1,6 x 5 m		50
45551	1,6 x 10 m		20
45564	3,2 x 10 m		20
45552	1,6 x 50 m	m in Rolle	1
45553	1,6 x 100 m	m in Rolle	1
45562	3,2 x 50 m	m in Rolle	1
45563	3,2 x 100 m	m in Rolle	1

MULCHVLIESSTOFF BRAUN



50 g/m²

Nr.	Spezifikation		
45556	1,6 x 5 m		50
45557	1,6 x 10 m		20
45565	3,2 x 10 m		20
45558	1,6 x 50 m	m in Rolle	1
45559	1,6 x 100 m	m in Rolle	1

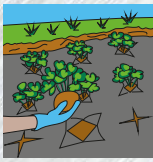

VLIESTOFF MIT KERBEN FÜR ERDBEERSTRÄUCHER

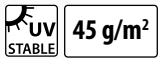

Nr.	Spezifikation	
45535	1,6 x 5 m	18



VERANKERUNGSTIFT ZUR BEFESTIGUNG DES VLIESTOFFS

10x

Nr.	Spezifikation	
45555	11,5 cm	1

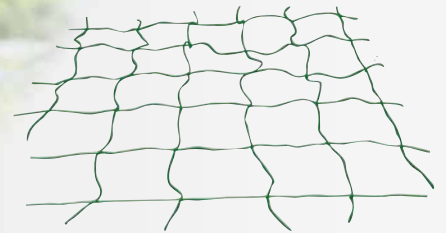

NETZ FÜR GURKEN

Nr.	Spezifikation	velikost oka	
45560	2 x 10 m	10 x 10 cm	100



BINDUNGSBAND, GEZAHNT

50x

Nr.	Spezifikation	
23840		20

GLASFASERSTAB

Nr.	Spezifikation	
45036	180 cm Ø 7,9 mm	100



GARTENSTAB, KUNSTSTOFFBESCHICHTET

Nr.	Spezifikation		Nr.	Spezifikation		Nr.	Spezifikation	
45650	90 cm Ø 8 mm	25	45655	150 cm Ø 11 mm	25	45659	180 cm Ø 16 mm	25
45651	120 cm Ø 8 mm	25	45656	180 cm Ø 11 mm	25	45660	210 cm Ø 16 mm	25
45652	150 cm Ø 8 mm	25	45661	210 cm Ø 11 mm	25	45662	150 cm Ø 20 mm	10
45653	90 cm Ø 11 mm	25	45657	120 cm Ø 16 mm	25	45663	180 cm Ø 20 mm	10
45654	120 cm Ø 11 mm	25	45658	150 cm Ø 16 mm	25	45664	210 cm Ø 20 mm	10



SPIRALSTAB FÜR TOMATEN

Nr.	Spezifikation	
44041	1,2 m, Ø 5,5 mm Komaxit - grün	10
44042	1,5 m, Ø 6 mm Komaxit - grün	10
44043	1,8 m, Ø 6 mm Komaxit - grün	10
45049	1,8 m, Ø 7 mm Komaxit - grün	10
45044	1,8 m, Ø 7 mm Komaxit - silber	10
44050	2,2 m, Ø 7 mm Komaxit - grün	10



KUNSTSTOFFKUPPLUNG

MOQ 10

Nr.	Spezifikation	
45670	8 mm	10
45671	11 mm	10
45672	16 mm	10
45673	20 mm	10



BINDUNGSBAND MIT KLETTVERSCHLUSS

Nr.	Spezifikation	
45471	12 mm x 5 m	1



PVC-BINDEDRAHT

Nr.	Spezifikation	
45043	30 m	30



GUMMIERTER BINDEDRAHT

Nr.	Spezifikation	
23845	3 mm x 8 m	30
23846	4 mm x 6 m	30
23847	5 mm x 4 m	30



BINDUNGSBÄNDER

3x

Nr.	Spezifikation	
45472	3 cm x 3 m, 3 stck	36



BINDUNGSBAND

Nr.	Spezifikation	
45473	3 cm x 50 m	60



KNIESCHONER

Nr.	Spezifikation	
45086	40 x 18 x 2 cm	50



GARTENHOCKER, KLAPPBAR

- wendbar - Kniebank, Sitz

Nr.	Spezifikation	
45074	58 x 48 x 28 cm	4



KORB, KLAPPBAR

Nr.	Spezifikation	
45093	40 x 25 x 23 cm	10



KUNSTSTOFFBEHÄLTER FLEXIBEL

MADE IN EU

Nr.	Spezifikation	
39192	26 l	20
39193	42 l	20



LAUBKORB, KLAPPBAR

Nr.	Spezifikation	
45047	55 x 70 cm, 3 Griffe	20



LAUBSACK

Nr.	Spezifikation	
44960	200 l 60 x 60 x 55 cm	50



FESTA[®]
AQUATIC



FESTA[®]
AQUATIC
PISTOLE

- 7 Funktionen
- vorderer Abzug mit Sicherheitsverschluss
- einfache Durchflussregelung



Nr.	Spezifikation	
45386		12



FESTA[®]
AQUATIC
PISTOLE

- stufenlose Stromregelung
- vorderer Abzug mit Sicherheitsverschluss
- einfache Durchflussregelung



Nr.	Spezifikation	
45388		12



FESTA[®]
AQUATIC
DRUCKSTCKPRÜHER

- stufenlose Stromregelung



Nr.	Spezifikation	
45389		24



FESTA[®]
AQUATIC
SET MIT SPRÜHER

- stufenlose Stromregelung



Nr.	Spezifikation	
45385	4 stck	12



FESTA[®]
AQUATIC
KUPPLUNG

1/2"	
------	--

Nr.	Spezifikation	
45390		24



FESTA[®]
AQUATIC
SCHNELLKUPPLUNG

1/2"	
------	--

Nr.	Spezifikation	
45392		24



FESTA[®]
AQUATIC
ANSCHLAGSCHNELLKUPPLUNG

1/2"	
------	--

Nr.	Spezifikation	
45394		24



FESTA[®]
AQUATIC
KUPPLUNG

3/4"	
------	--

Nr.	Spezifikation	
45391		24



FESTA[®]
AQUATIC
SCHNELLKUPPLUNG

3/4"	
------	--

Nr.	Spezifikation	
45393		24



FESTA[®]
AQUATIC
ANSCHLAGSCHNELLKUPPLUNG

3/4"	
------	--

Nr.	Spezifikation	
45395		24

FESTA
AQUATIC

ADAPTER



Nr.	Spezifikation	
45396		24



NEW

FESTA
AQUATIC

GARTENSCHLAUCH
PROFI



Nr.	Spezifikation	
45372	1/2" 25 m	1
45373	1/2" 50 m	1
45374	3/4" 25 m	1
45375	3/4" 50 m	1
45376	1" 25 m	1
45377	1" 50 m	1



FESTA
AQUATIC

REGNER

· 19 Düsen davon 8 davon ausschaltbar



Nr.	Spezifikation	
45398		6

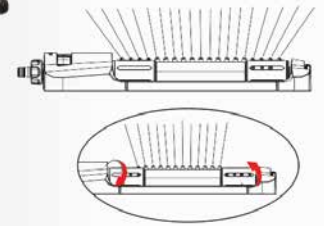

FESTA
AQUATIC

REGNER

· verstellbare Arme mit Düsen



Nr.	Spezifikation	
45399		12



FESTA
AQUATIC

VERTEILER

· stufenlose Durchflussregelung



Nr.	Spezifikation	
45400	2-Wege	6



FESTA
AQUATIC

VERTEILER

· stufenlose Durchflussregelung



Nr.	Spezifikation	
45401	4-Wege	6



ROSA
PISTOLE

- 10 Funktionen
- vorderer Abzug mit Sicherheitsverschluss

0,7bar min
5,5bar max



Nr. Spezifikation
45124 12

ROSA
PISTOLE

- 10 Funktionen
- Abzug mit Sicherheitsverschluss
- einfache Durchflussregelung

0,7bar min
5,5bar max



Nr. Spezifikation
45125 12



ROSA

Watering system



ROSA
PISTOLE

- 7 Funktionen
- Abzug mit Sicherheitsverschluss

0,7bar min
5,5bar max



Nr. Spezifikation
45126 12

ROSA
DELUX-PISTOLE

- 7 Funktionen
- Abzug mit Sicherheitsverschluss
- einfache Durchflussregelung

0,7bar min
5,5bar max



Nr. Spezifikation
45123 metallisch 12

ROSA
PISTOLE

- 6 Funktionen
- Abzug mit Sicherheitsverschluss
- einfache Durchflussregelung

0,7bar min
5,5bar max



Nr. Spezifikation
45117 12

ROSA
DELUX-PISTOLE

- 6 Funktionen
- Abzug mit Sicherheitsverschluss
- einfache Durchflussregelung

0,7bar min
5,5bar max



Nr. Spezifikation
45118 Kopf aus Metall 12

ROSA
PISTOLE

- 5 Funktionen
- Abzug mit Sicherheitsverschluss
- einfache Durchflussregelung

0,7bar min
5,5bar max



Nr. Spezifikation
45110 12

ROSA
PISTOLE

- Rosettenpistole
- einfache Durchflussregelung

0,7bar min
5,5bar max



Nr. Spezifikation
45116 12

ROSA
PISTOLE

- Metallkopf
- Abzug mit Sicherheitsverschluss
- einfache Durchflusskontrolle

0,7 bar min
5,5 bar max

Nr. Spezifikation 12  



ROSA
PISTOLE

- Abzug mit Sicherheitsverschluss
- einfache Durchflussregelung

0,7 bar min
5,5 bar max

Nr. Spezifikation 12  



ROSA
PISTOLE

- aus Metall
- Abzug mit Sicherheitsverschluss
- einfache Durchflussregelung

0,7 bar min
5,5 bar max

Nr. Spezifikation 12  



ROSA
PISTOLE-SET

- Abzug mit Sicherheitsverschluss
- einfache Durchflussregelung

0,7 bar min
5,5 bar max



Nr. Spezifikation 12  



ROSA
PISTOLE

- Abzug mit Sicherheitsverschluss
- einfache Durchflussregelung

0,7 bar min
5,5 bar max

Nr. Spezifikation 12  



ROSA
PISTOLE SET

- 6 Funktionen
- Abzug mit Sicherheitsverschluss
- einfache Durchflussregelung

0,7 bar min
5,5 bar max



Nr. Spezifikation 12  



ROSA
SPRÜHDÜSE

- stufenlose Stromregelung

10 bar max



Nr. Spezifikation 48  



ROSA
DRUCSTCKPRÜHER

- stromlinienförmig, klassischer Anschluss

0,7 bar min
5,5 bar max

Nr. Spezifikation 32  



ROSA
DRUCSTCKPRÜHER

- stufenlose Stromregelung

0,7 bar min
5,5 bar max



Nr. Spezifikation 60  



ROSA
SET MIT SPRÜHER

- stufenlose Stromregelung

0,7 bar min
5,5 bar max

Nr. Spezifikation 12  



ROSA
KUPPLUNG



Nr. Spezifikation 60

ROSA
SCHNELLKUPPLUNG



Nr. Spezifikation 60

ROSA
ANSCHLAG-
SCHNELLKUPPLUNG



Nr. Spezifikation 60

ROSA
KUPPLUNG



MOQ 20

Nr. Spezifikation 45296 MOQ 20

ROSA
SCHNELLKUPPLUNG



MOQ 20

Nr. Spezifikation 45298 MOQ 20

ROSA
ANSCHLAG-
SCHNELLKUPPLUNG



MOQ 20

Nr. Spezifikation 45294 MOQ 20

ROSA
KUPPLUNG



Nr. Spezifikation 45141 60

ROSA
SCHNELLKUPPLUNG



Nr. Spezifikation 45143 60

ROSA
ANSCHLAG-
SCHNELLKUPPLUNG



Nr. Spezifikation 45139 60

ROSA
KUPPLUNG



MOQ 20

Nr. Spezifikation 45297 MOQ 20

ROSA
SCHNELLKUPPLUNG



MOQ 20

Nr. Spezifikation 45299 MOQ 20

ROSA
ANSCHLAG-
SCHNELLKUPPLUNG



MOQ 20

Nr. Spezifikation 45295 MOQ 20

ROSA
REDUKTION 1/2" - 3/4"



Nr. Spezifikation 45213 1/2" - 3/4" 60

ROSA
REDUKTION 3/4" - 1"



Nr. Spezifikation 45216 3/4" - 1" 48

ROSA
KUPPLUNG



Nr. Spezifikation 45218 1" 48

ROSA
ADAPTER



Nr.	Spezifikation	
45130	1/2" + 3/4"	60
45131	3/4" + 1"	60

ROSA
ADAPTER



Nr.	Spezifikation	
45217		48

ROSA
SCHNELLKUPPLUNG



Nr.	Spezifikation	
45219		48

ROSA
ADAPTER



Nr.	Spezifikation	
45289	1/2" + 3/4"	MOQ 20
45290	3/4" + 1"	MOQ 20

ROSA
SCHNELLKUPPLUNGS SET



Nr.	Spezifikation	
45144		60

ROSA
ANSCHLUSSVENTIL



Nr.	Spezifikation	
45135		60

ROSA
ADAPTER



Nr.	Spezifikation	
45133		60

ROSA
ADAPTER



Nr.	Spezifikation	
45132		60

ROSA
ADAPTER



Nr.	Spezifikation	
45136		60

ROSA
ADAPTER

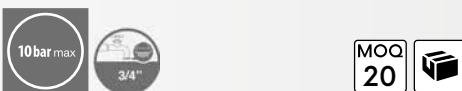

Nr.	Spezifikation	
45292		MOQ 20

ROSA
ADAPTER

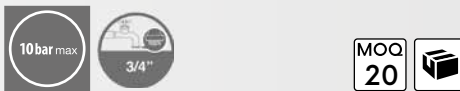

Nr.	Spezifikation	
45291		MOQ 20

ROSA
ADAPTER



Nr.	Spezifikation	
45293		MOQ 20

ROSA
ADAPTER

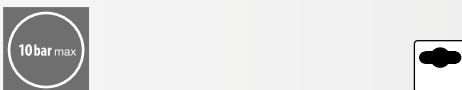

Nr.	Spezifikation	
45137		60

ROSA
ADAPTER

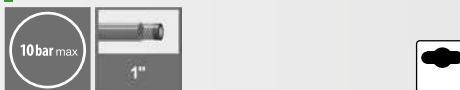

Nr.	Spezifikation	
45215		48

ROSA
ADAPTER



Nr.	Spezifikation	
45145		60

ROSA
GABEL "Y"

· mit Ventil

0,7 bar min
5,5 bar max

Nr. Spezifikation
45134

12 



ROSA
VERKAUFSSET

· Set-Inhalt
45113 15 stck
45117 10 stck
45120 15 stck
4513240 stck
45131 40 stck
4513340 stck
4514225 stck
4514320 stck
4514020 stck

225x

Nr. Spezifikation
45146



ROSA
IMPULS
SPRINKLER

· Impuls

0,7 bar min
5,5 bar max

Nr. Spezifikation
45162



24 



ROSA
REGNER

· 8 Funktionen

0,7 bar min
5,5 bar max

Nr. Spezifikation
45154



48 



ROSA
REGNER

· rotierend
· 2 Arme

0,7 bar min
5,5 bar max

Nr. Spezifikation
45153



24 



ROSA
REGNER

· rotierend
· 3 Arme

0,7 bar min
5,5 bar max

Nr. Spezifikation
45152



24 



ROSA
PENDELREGNER

· 17 Düsen

0,7 bar min
5,5 bar max

ALU

Nr. Spezifikation
45158



6 

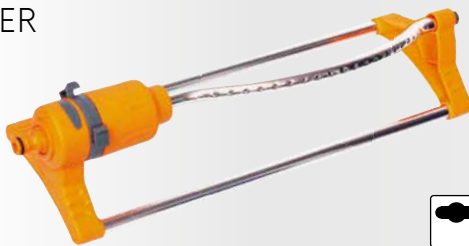

ROSA
REGNER

· pyramidenförmig

0,7 bar min
5,5 bar max

Nr. Spezifikation
45167



12 



ROSA
SOCKEL FÜR
IMPULSSPRINKLER

0,7 bar min
5,5 bar max

3/4"

Nr. Spezifikation
45155



24 



ROSA
IMPULS
SPRINKLER

· auf einem Stativ

0,7 bar min
5,5 bar max

Nr. Spezifikation
45163 Impuls auf Stativ



20 



ROSA

REGNER

· spitzig



Nr. Spezifikation
45160 25

ROSA

REGNER

· mit Gießkannenaufsatz und mit Ventil



Nr. Spezifikation
45156 12

ROSA

TIMER

· 0 - 120 min.



Nr. Spezifikation
45147 24

ROSA

**IMPULS-
SPRINKLER**

· aus Messing



Nr. Spezifikation
45150 12

ROSA

IMPULS-SPRINKLER



Nr. Spezifikation
45151 12

ROSA

**IMPULS-
SPRINKLER,
MIT SPITZEN**



Nr. Spezifikation
45168 Kunststoffspitze 12
45169 Metall-Schrott 12

ROSA

**IMPULSSPRINKLER,
MIT SPITZEN**



Nr. Spezifikation
45161 Kunststoffspitze 20

ROSA

**KREISREGNER,
MIT STIFT**

· 3 Arme
· zweiweg



Nr. Spezifikation
45164 Kunststoffspitze 12

ROSA

**SPITZEN-
GESTELL**



Nr. Spezifikation
45159 12

ROSA

SPITZENGESTELL



Nr. Spezifikation
45179 12

ROSA

SCHLAUCHFÜHRUNG

Nr. Spezifikation



45186 48

ROSA

**IMPULS-
SPRINKLER**



Nr. Spezifikation
45185 20

ROSA

IMPULS-SPRINKLER



Nr. Spezifikation
45184 20

ROSA
KUPPLUNG
MESSING



Nr. Spezifikation
45192 48

ROSA
SCHNELLKUPPLUNG
MESSING



Nr. Spezifikation
45194 48

ROSA
ANSCHLAG
SCHNELLKUPPLUNG
MESSING

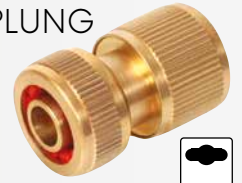

Nr. Spezifikation
45190 48

ROSA
KUPPLUNG
MESSING

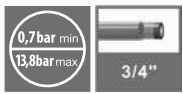

Nr. Spezifikation
45193 48

ROSA
SCHNELLKUPPLUNG
MESSING



Nr. Spezifikation
45195 48

ROSA
ANSCHLAG
SCHNELLKUPPLUNG
MESSING



Nr. Spezifikation
45191 48

ROSA
ADAPTER,
MESSING



Nr. Spezifikation
45196 mit Innengewinde 1/2" + 3/4" 48

ROSA
ADAPTER,
MESSING



Nr. Spezifikation
45197 mit Innengewinde 3/4" 48

ROSA
ADAPTER,
MESSING



Nr. Spezifikation
45199 mit Innengewinde 1" 48

ROSA
ADAPTER,
MESSING



Nr. Spezifikation
45198 mit Innengewinde 3/4 + 1" 48

ROSA
ADAPTER,
MESSING



Nr. Spezifikation
45200 mit Außengewinde 3/4 48

ROSA
SPRÜHDÜSE
MESSING



Nr. Spezifikation
45206 verstellbar 48

ROSA
ADAPTER,
MESSING



Nr. Spezifikation
45203 Zwischenstück für 2 Schnellkupplungen 48

ROSA
ADAPTER,
MESSING



Nr. Spezifikation
45204 Zwischenstück für 3 Schnellkupplungen 48

ADAPTER



Nr. Spezifikation
45211 Außengewinde 1" 25

ROSA
DICHTUNGSSET

für Positionen
45110, 45111, 45118, 45120, 45121, 45123,
45125, 45126, 45130, 45131, 45132, 45134,
45135, 45152, 45153, 45154, 45155, 45156,
45162, 45177, 45178, 45180, 45196, 45197,
45198



Nr. Spezifikation
45175 1

ROSA
DICHTUNGEN FÜR KUPPLUNGEN
UND VERBINDER

50x

Nr. Spezifikation
45187 1



NEW



ROSA

GARTENSCHLAUCH DURCHSICHTIG



Nr.	Spezifikation	
45342	1/2" 10 m	1
45343	1/2" 15 m	1
45344	1/2" 20 m	1
45345	1/2" 25 m	1
45346	1/2" 50 m	1
45341	3/4" 10 m	1
45347	3/4" 15 m	1
45348	3/4" 20 m	1
45349	3/4" 25 m	1
45351	3/4" 50 m	1
45352	1" 15 m	1
45353	1" 25 m	1
45354	1" 50 m	1

NEW



FESTA AQUATIC

GARTENSCHLAUCH PROFI



Nr.	Spezifikation	
45372	1/2" 25 m	1
45373	1/2" 50 m	1
45374	3/4" 25 m	1
45375	3/4" 50 m	1
45376	1" 25 m	1
45377	1" 50 m	1



ROSA

SPIRALSCHLAUCH SET



Nr.	Spezifikation	
45300	7,5 m	6
45301	15 m	8



ROSA

SCHLAUCHHALTERUNG



Nr.	Spezifikation	
45178	1/2" 60 m	5



ROSA

METALL-SCHLAUCHWAGEN



Nr.	Spezifikation	
45183	1/2" 60 m	5



ROSA

SCHLAUCHWAGEN



Nr.	Spezifikation	
45177	1/2" 60 m	5



ROSA

SCHLAUCHHALTERUNG



Nr.	Spezifikation	
45182	1/2" 40 m	4

ROSA

SCHLAUCHAUFRÖLLER

inkl. Schlauch 1/2" 20 m



Nr.	Spezifikation	
45176		1



ROSA

SCHLAUCHHALTERUNG



Nr.	Spezifikation	
45174		60



SCHLAUCHTRÄGER

max. 30 m, 1/2" Gartenschlauch

Nr.	Spezifikation	
45350	Max.Traglast: 20 kg	1

SCHLAUCHKUPPLUNG

Nr.	Spezifikation	
45220	1/2" Gewinde 3/4"	10
45221	3/4" Gewinde 1"	10
45222	1" Gewinde 1"	10



SCHLAUCHTÜLLE

Nr.	Spezifikation	
45223	1/2" Gewinde 3/4"	10
45224	3/4" Gewinde 1"	10
45225	1" Gewinde 1"	10



SCHLAUCHREDUZIERER

Nr.	Spezifikation	
45226	1/2"- 3/4" Gewinde 1"	10
45227	1" - 3/4" Gewinde 1"	10
45228	1" - 1/2" Gewinde 1"	10



SPRÜHGERÄT

Nr.	Spezifikation	
45229		10



Nr.	průměr	
45603	16 - 25 mm	2
45604	20 - 32 mm	2
45605	25 - 40 mm	2
45606	30 - 45 mm	2
45607	32 - 50 mm	2
45608	40 - 60 mm	2
45609	50 - 70 mm	2
45610	60 - 80 mm	2
45611	70 - 90 mm	2
45612	80 - 100 mm	2
45613	90 - 110 mm	2
45614	100 - 120 mm	2
45615	110 - 130 mm	2
45616	120 - 140 mm	2
45617	130 - 150 mm	2
45618	140 - 160 mm	2
45619	150 - 170 mm	2



Nr.	průměr	breite	
45623	16 - 25 mm	9 mm	2
45624	20 - 32 mm	9 mm	2
45625	25 - 40 mm	12 mm	2
45626	30 - 45 mm	12 mm	2
45627	32 - 50 mm	12 mm	2
45628	40 - 60 mm	12 mm	2
45629	50 - 70 mm	12 mm	2
45630	60 - 80 mm	12 mm	2
45631	70 - 90 mm	12 mm	2
45632	80 - 100 mm	12 mm	2
45633	90 - 110 mm	12 mm	2
45634	100 - 120 mm	12 mm	2
45635	110 - 130 mm	12 mm	2
45636	120 - 140 mm	12 mm	2
45637	130 - 150 mm	12 mm	2
45638	140 - 160 mm	12 mm	2
45639	150 - 170 mm	12 mm	2

SCHLAUCHKLEMME

Zn **MOQ 2**

Nr.	průměr	
45600	8 - 12 mm	2
45601	10 - 16 mm	2
45602	12 - 20 mm	2

SCHLAUCHKLEMME

INOX **MOQ 2**

Nr.	průměr	breite	
45620	8 - 12 mm	9 mm	2
45621	10 - 16 mm	9 mm	2
45622	12 - 20 mm	9 mm	2



DOPPELTES GARTENVENTIL

Nr.	
45105	8



GARTENVENTIL

Nr.	Spezifikation	
45100	1/2"	12
45101	3/4"	10
45102	1"	6



KUGELHAHN

Nr.	Spezifikation	
45106	1/2"	12
45107	3/4"	10
45108	1"	8



KUNSTSTOFF-GIESSKANNE



Nr.	Spezifikation	
45280	2,5 l	10
45283	5 l	10
45285	10 l	10
45286	12 l	10
45287	15 l	10

HORNBUCH

Nr.	Spezifikation	
45104	1/2" x 3/8"	10



FESTA

GARTEN DRUCKSTÜCKSPRÜHER 12 L

max. Druck	2,5 Bar
Volumen	12 l
Schlauchlänge	3 m
Abmessungen	32 x 25 x 59 cm



Nr.	Spezifikation	
45249	Garten-Druckstückprüher 12 L	1

FESTA

**DRUCKGARTEN-
SPRÜHER**

Nr.	Spezifikation	
45247	12 l	1
45248	16 l	1



Nr.	Spezifikation	
45263	Ersatzschlauch für das Sprühgerät	1
45251	Dichtungssatz	1
45254	Ersatzdüse	1
45257	Ersatzgriff	1
45261	Ersatzstange 370 mm	1
45267	Ersatzstange 45 - 250 cm	1
45268	Ersatzstange 65 - 260 cm	1

FESTA

**DRUCKGARTEN-
SPRÜHER**

Nr.	Spezifikation	
45244	3 l	6
45245	5 l	6
45246	8 l	6



Nr.	Spezifikation	
45262	Ersatzschlauch für das Sprühgerät	1
45250	Dichtungssatz	1
45253	Ersatzdüse	1
45256	Ersatzgriff	1
45260	Ersatzstange 370 mm	1

für Sprühgeräte 45244, 45245, 45246



für Sprühgeräte 45247, 45248

93 - 250 cm



TELESKOPISCHE SPRÜHSTANGE

Nr.	typ	
45267	45 - 250 cm	inox 1
45268	65 - 260 cm	fiberglass 1

TELESKOPISCHE SPRÜHSTANGE

Nr.	Spezifikation	
45269		1



ERSATZSCHLAUCH FÜR DAS SPRÜHGERÄT

Nr.	typ	
45263	für Sprühgerät 45247, 45248	1
45262	für Sprühgerät 45244, 45245, 45246	1



HERBIZIDGLOCKE

für Sprühgeräte 45247, 45248, 45249

Nr.	velikost	délka	breite	výška	
45265	gering	230 mm	90 mm	130 mm	1
45266	großer	370 mm	140 mm	200 mm	1



FESTA

HANDDRUCK-
SPRÜHER



Nr.	typ	
45242	1,5 l	20
45241	2 l	20

HANDSPRÜHER



Nr.	typ	
45239	0,5 l	1
45240	0,7 l	1



45173

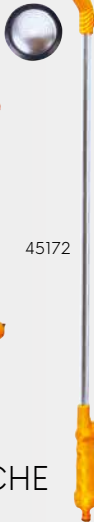

45172

ROSA
DUSCHE



Nr.	Spezifikation	
45171	verstellbar	12

ROSA
DUSCHE



Nr.	Spezifikation	
45170	3 Füße	6

ROSA
DUSCHE
HANDDUSCHE



Nr.	Spezifikation	
45172	Mit Ventil	12
45173	10 Funktionen	12



FESTA[®]

system click
ON - OFF

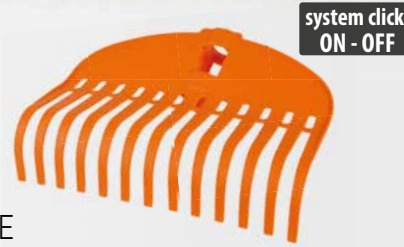

system click
ON - OFF



system click
ON - OFF

FESTA
KUNSTSTOFFHARKE

Nr.	Anzahl Lamellen	breite	vyška	
45327	13	240 mm	200 mm	12

FESTA
KUNSTSTOFFHARKE

Nr.	Anzahl Lamellen	breite	
45325	12	410 mm	12



system click
ON - OFF



system click
ON - OFF

FESTA
KUNSTSTOFFHARKE

Nr.	Anzahl Lamellen	breite	vyška	
45328	23	480 mm	280 mm	12

FESTA
KUNSTSTOFFHARKE

Nr.	Anzahl Lamellen	breite	
45326	18	580 mm	12



system click
ON - OFF



system click
ON - OFF

FESTA
KUNSTSTOFFHARKE

Nr.	Anzahl Lamellen	breite	vyška	
45329	35	760 mm	310 mm	1

FESTA
STRASSENBESEN

Nr.	Spezifikation	
45323	37 cm	16

FESTA
ALUMINIUMSTIEL

ALU



system click
ON - OFF

Nr.	Spezifikation	
45330	161 cm	24
45331	100 cm	24



FESTA

VERSTELLBARER METALLRECHEN, TELESKOPISCH



Zn

Nr.	Anzahl Lamellen	rozsah	
44965	15	200 - 590 mm	12

VERSTELLBARE METALLRECHEN



Zn

Nr.	Anzahl Lamellen	váha	rozsah	
45050	15	1200 g	200 - 590 mm	25

FESTA

METALL-LAMELLENRECHEN

Federstahl



Nr.	breite	Anzahl Lamellen	
45071	55 cm	22	1

FESTA

METALL-LAMELLENRECHEN, MIT STIEL



MOQ 3

Nr.	breite	schaftlänge	
61150	55 cm	160 cm	3



METALL-LAMELLENRECHEN, MIT STIEL



MOQ 3

METALL-LAMELLENRECHEN

Nr.	breite	Anzahl Lamellen	
45051	40 cm	22	60

Nr.	breite	schaftlänge	
61130	40 cm	160 cm	3



METALLRECHEN MIT STIEL



MOQ 3

METALLRECHEN DRAHT

Nr.	breite	Anzahl Lamellen	
45052	45 cm	22	36

Nr.	breite	schaftlänge	
61131	45 cm	160 cm	3

KUNSTSTOFFHARKE



Nr.	breite	Anzahl Lamellen	
45320	60 cm	24	10

KUNSTSTOFFRECHEN MIT STIEL



Nr.	breite	Anzahl Lamellen	schaftlänge	
61132	60 cm	24	160 cm	3

MOQ
3

KUNSTSTOFFHARKE



Nr.	breite	Anzahl Lamellen	
45055	50 cm	22	10

KUNSTSTOFFRECHEN MIT STIEL



Nr.	breite	Anzahl Lamellen	schaftlänge	
61133	50 cm	22	160 cm	3

MOQ
3

KUNSTSTOFFHARKE



Nr.	breite	Anzahl Lamellen	
45321	40 cm	23	20

KUNSTSTOFFRECHEN MIT STIEL



Nr.	Anzahl Lamellen	schaftlänge	
61134	23	160 cm	3

MOQ
3

KUNSTSTOFFHARKE



Nr.	breite	Anzahl Lamellen	
45054	40 cm	23	10

KUNSTSTOFFRECHEN MIT STIEL



Nr.	breite	Anzahl Lamellen	schaftlänge	
61135	40 cm	23	160 cm	3

MOQ
3

KUNSTSTOFFHARKE



Nr.	breite	Anzahl Lamellen	
45053	58 cm	16	35

KUNSTSTOFFRECHEN MIT STIEL



Nr.	breite	Anzahl Lamellen	schaftlänge	
61141	58 cm	16	160 cm	3

MOQ
3

KUNSTSTOFF-FRECHEN, MIT NIVELLIERKANTE



Nr.	breite	anzahl der Zähne	
45070	41 cm	14	4

KUNSTSTOFFFRECHEN, MIT NIVELLIERKANTE, MIT STIEL



MOQ 3

Nr.	breite	anzahl der Zähne	schaftlänge	
61142	41 cm	14	160 cm	3

METALLRECHEN



Nr.	breite	anzahl der Zähne	
61030	24 cm	10	24
61031	29 cm	12	24
61032	34 cm	14	24
61033	40 cm	16	24

METALLRECHEN MIT STIEL



MOQ 3

Nr.	breite	anzahl der Zähne	schaftlänge	
61060	24 cm	10	160 cm	3
61061	29 cm	12	160 cm	3
61062	34 cm	14	160 cm	3
61063	40 cm	16	160 cm	3

METALL VERTIKUTIERRECHEN



- Hammerschlaglack

Nr.	breite	anzahl der Zähne	
61045	30 cm	12	25
61046	39 cm	14	25
61047	45 cm	16	25

VERTIKUTIERRECHEN MIT STIEL



- Hammerschlaglack

MOQ 3

Nr.	breite	anzahl der Zähne	schaftlänge	
61143	30 cm	12	160 cm	3
61144	39 cm	14	160 cm	3
61145	45 cm	16	160 cm	3

VERTIKUTIERRECHEN



Nr.	breite	anzahl der Zähne	
61048	35 cm	11 21	12

VERTIKUTIERRECHEN MIT STIEL



MOQ 3

Nr.	breite	anzahl der Zähne	schaftlänge	
61146	35 cm	11 21	160 cm	3

METALLRECHEN MIT STIEL, GLASFASER



MOQ 3

Nr.	breite	anzahl der Zähne	schaftlänge	
61034	34 cm	14	160 cm	3



FESTA

SPITZES SPATENBLATT



Nr.	Spezifikation	schaftlänge	
61006	19 x 28 cm	120 cm	5

FESTA

KLEINER SPITZER SPATEN

für Gewächshausarbeiten geeignet



Nr.	Spezifikation	schaftlänge	
61008	19 x 28 cm	85 cm	5

FESTA

ABGERUNDETES SPATENBLATT



Nr.	Spezifikation	schaftlänge	
61005	20 x 29 cm	120 cm	5

FESTA



FESTA

RUNDER SPATEN, VERLÄNGERT

für Figuren, die größer als 180 cm sind



Nr.	Spezifikation	schaftlänge	
61157	20 x 29 cm	130 cm	5

FESTA

SPITZER SPATEN, VERLÄNGERT

für Figuren, die größer als 180 cm sind



Nr.	Spezifikation	schaftlänge	
61158	19 x 28 cm	130 cm	5

FESTA

STANDARD-SCHAUFEL



Nr.	Spezifikation	schaftlänge	
61155	24 x 29 cm	120 cm	5

FESTA

HEUGABEL



Nr.	Spezifikation	schaftlänge	
61156	19 x 28 cm	130 cm	5

FESTA

GRABGABEL



Nr.	Spezifikation	schaftlänge	
61007	18 x 28 cm	130 cm	5

FESTA

GRABGABEL, GLASFASER-STIEL

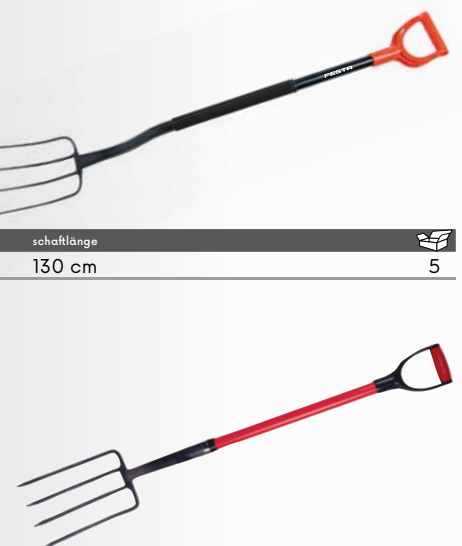

Nr.	Spezifikation	schaftlänge	
61010	18 x 30 cm	95 cm	12

SPITZER SPATEN, GRIFF AUS FASERGLASS



Nr.	Spezifikation	schaftlänge	
61029	19 x 30 cm	105 cm	12

RUNDER SPATEN, GRIFF AUS FIBERGLAS



Nr.	Spezifikation	schaftlänge	
61015	19 x 30 cm	105 cm	12



ALUMINIUMSCHAUFEL MIT STIEL

· Griffknöchelaufsatz aus Buchenholz

ALU		MOQ 3
Nr.	Spezifikation	schaftlänge
61057	26 x 29 cm	130 cm
61056	34 x 30 cm	130 cm



ALUMINIUM SCHAUFEL

ALU		
Nr.	Spezifikation	
61026	26 x 29 cm	10
61025	34 x 30 cm	10



KOHLESCHAUFEL MIT STIEL

		MOQ 3
Nr.	Spezifikation	schaftlänge
61089	35 x 35 cm	130 cm



KOHLENSCHAUFEL

Nr.	Spezifikation	
61021	35 x 35 cm	10



HERZSCHAUFEL MIT STIEL

· Hammerschlaglack · Hammerschlaglack
· Griffknöchelaufsatz aus Buchenholz

		MOQ 3
Nr.	Spezifikation	schaftlänge
61050	26 x 28 cm	130 cm



HERZSCHAUFEL

Nr.	Spezifikation	
61000	26 x 28 cm	12



HERZSCHAUFEL MIT STIEL

· Griffknöchelaufsatz aus Buchenholz

		MOQ 3
Nr.	Spezifikation	schaftlänge
61088	26 x 28 cm	130 cm



HERZSCHAUFEL

Nr.	Spezifikation	
61020	26 x 28 cm	12



STANDARD-SCHAUFEL MIT STIEL

· Hammerschlaglack
· Griffknöchelaufsatz aus Buchenholz

		MOQ 3
Nr.	Spezifikation	schaftlänge
61051	24 x 29 cm	130 cm



STANDARD-SCHAUFEL

Nr.	Spezifikation	
61001	24 x 29 cm	12





STANDARD-SCHAUFEL

Nr.	Spezifikation	
61022	24 x 29 cm	12



STANDARD-SCHAUFEL MIT STIEL

· Griffknöchelaufsatz aus Buchenholz

MOQ
3

Nr.	Spezifikation	schaftlänge	
61090	24 x 29 cm	130 cm	3
61053	24 x 29 cm	130 cm "T", handhaben	3



HOLSTEINER SCHAUFEL

Nr.	Spezifikation	
61058	25 x 27 cm	12



HOLSTEINER SCHAUFEL MIT STIEL

· Griffknöchelaufsatz aus Buchenholz

MOQ
3

Nr.	Spezifikation	schaftlänge	
61059	25 x 27 cm	130 cm	3



SCHMALE SCHAUFEL

· Hammerschlaglack

Nr.	Spezifikation	
61002	19 x 27 cm	12



SCHMALE SCHAUFEL MIT STIEL

· Hammerschlaglack
· Griffknöchelaufsatz aus Buchenholz

MOQ
3

Nr.	Spezifikation	schaftlänge	
61052	19 x 27 cm	130 cm	3



SCHMALE SCHAUFEL

Nr.	Spezifikation	
61024	19 x 27 cm	12



SCHMALE SCHAUFEL MIT STIEL

· Griffknöchelaufsatz aus Buchenholz

MOQ
3

Nr.	Spezifikation	schaftlänge	
61054	19 x 27 cm	130 cm	3



PLASTIK SCHAUFEL

Nr.	Spezifikation	
61027	24 x 26 cm	12



SPITZSPATEN MIT „T“-STIEL

· Hammerschlaglack

MOQ
3

Nr.	Spezifikation	schaftlänge	
61161	22 x 30 cm	90 cm	3



SPITZES SPATENBLATT

· Hammerschlaglack

Nr.	Spezifikation	
61004	22 x 30 cm	12



SPITZSPATEN MIT „T“-STIEL

MOQ
3

Nr.	Spezifikation	schaftlänge	
61097	19 x 30 cm	90 cm	3



SPITZES SPATENBLATT

Nr.	Spezifikation	
61019	22 x 30 cm	12



SPITZER SPATEN, GESCHMIEDET, MIT „T“-STIEL

Nr.	Spezifikation	schaftlänge	MOQ
61162	22 x 25 cm	90 cm	3
61223	handhaben	90 cm	1



SPITZER SPATEN GESCHMIEDET

Nr.	Spezifikation	
61013	22 x 25 cm	12



ABGERUNDETER SPATEN MIT „T“-STIEL

· Hammerschlaglack

MOQ
3

Nr.	Spezifikation	schaftlänge	
61163	21 x 30 cm	90 cm	3



ABGERUNDETES SPATENBLATT

· Hammerschlaglack

Nr.	Spezifikation	
61003	21 x 30 cm	12





ABGERUNDETES SPATENBLATT

Nr.	Spezifikation	
61018	21 x 30 cm	12



ABGERUNDETER SPATEN MIT „T“-STIEL

MOQ 3

Nr.	Spezifikation	schaftlänge	
61098	21 x 30 cm	90 cm	3



STECHSPATEN

Nr.	Spezifikation	
61014	14 x 37 cm	12



STECHSPATEN MIT „T“-STIEL

Nr.	Spezifikation	schaftlänge	MOQ	
61164	14 x 37 cm	90 cm	3	3
61203	Stiel	90 cm		1



HEUGABEL

Nr.	Spezifikation	
61009	20 x 32 cm	12



HEUGABEL MIT STIEL

Griffknöchelaufsatz aus Buchenholz

MOQ 3

Nr.	Spezifikation	schaftlänge	
61165	20 x 32 cm	90 cm	3



GRABGABEL, GESCHMIEDET

Nr.	Spezifikation	
61012	22 x 30 cm	12



GRABGABEL, GESCHMIEDET, MIT „T“-STIEL

Nr.	Spezifikation	schaftlänge	MOQ	
61166	22 x 30 cm	90 cm	3	3
61222	Stiel	90 cm		1



GRABGABEL

Nr.	Spezifikation	
61044	20 x 30 cm	12



GRABGABEL MIT „T“-STIEL

Nr.	Spezifikation	schaftlänge	MOQ	
61028	20 x 30 cm	90 cm	3	3
61209	Stiel	90 cm		1



SPITZHACKE, GESCHMIEDET, MIT STIEL

Nr.	Spezifikation	schaftlänge	MOQ	
61111	0,4 kg	120 cm	3	
61112	0,6 kg	120 cm	3	
61224	handhaben	120 cm	1	

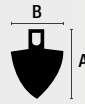

SPITZHACKE, GESCHMIEDET

Nr.	Spezifikation	A	B	MOQ	
61035	0,4 kg	180 mm	125 mm	1	
61036	0,6 kg	230 mm	160 mm	30	



FLACHHACKE, GESCHMIEDET, MIT STIEL

Nr.	Spezifikation	schaftlänge	MOQ	
61114	0,6 kg	120 cm	3	
61224	handhaben	120 cm	1	

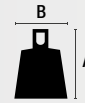

FLACHHACKE, GESCHMIEDET

Nr.	Spezifikation	A	B	MOQ	
61038	0,6 kg	165 mm	135 mm	20	



HACKE MIT STIEL

MOQ 3

Nr.	Spezifikation	schaftlänge	MOQ	
61290	75 mm	120 cm	3	
61291	125 mm	120 cm	3	
61292	175 mm	120 cm	3	

HACKE

Nr.	Spezifikation	MOQ	
61067	75 mm	1	
61068	125 mm	1	
61069	175 mm	1	



HERZHACKE MIT STIEL

MOQ 3

Nr.	Spezifikation	schaftlänge	MOQ	
61293	140 mm	120 cm	3	

HERZHACKE

Nr.	Spezifikation	MOQ	
61070	140 mm	40	



GESCHMIEDETE SPITZHACKE MIT STIEL

MOQ 3

Nr.	Spezifikation	schaftlänge	MOQ	
61121	1,5 kg	95 cm	3	
61042	2,5 kg	95 cm	3	

GESCHMIEDETE SPITZHACKE

Nr.	Spezifikation	MOQ	
61120	1,5 kg	6	
61040	2,5 kg	6	



FESTA

SCHNEESCHIEBER



Nr.	Spezifikation	
60006	46 x 34 cm	12
60206	46 x 34 cm, zusammengebaut	1

FESTA

SCHNEESCHIEBER



Nr.	Spezifikation	
60008	50 x 34 cm	12
60208	50 x 34 cm, zusammengebaut	1

SCHNEESCHIEBER



MADE IN EU

Nr.	Spezifikation	
60001	48 x 40 cm	10
60201	48 x 40 cm, zusammengebaut	1

SCHNEESCHIEBER



ALU

Nr.	Spezifikation	
60012	50 x 38 cm	12
60212	50 x 38 cm, zusammengebaut	1



EISMEISSEL

Nr.	Spezifikation		MOQ
60022	20 cm	3	3



EISMEISSEL

Nr.	Spezifikation	
60018	15 cm	20
60019	20 cm	24
60020	30 cm	20
61201	130 cm-Stiel	10



STREUSALZ

Nr.	Spezifikation	
43300	10 kg	1
43301	25 kg	1



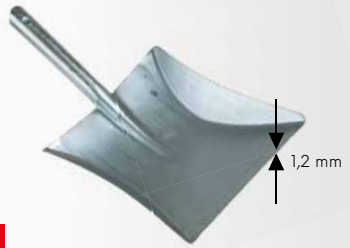

FESTA

METALLSCHAUFEL - VERSTÄRKT

Nr.	Spezifikation	
52176	22 x 23 cm	24

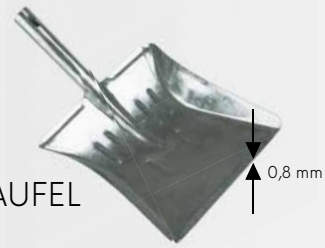

METALLSCHAUFEL

Zn

Nr.	Spezifikation	
52175	22 x 23 cm	50



HANDFEGER MIT SCHAUFEL

MADE IN EU

Nr.	Spezifikation	
52168		26



HANDFEGER MIT SCHAUFEL

MADE IN EU

Nr.	Spezifikation	
52173		26



STAHLBÜRSTE ZUR REINIGUNG VON FUGEN MIT STIEL

Nr.	schaftlänge	
52198	140 cm	1



HANDFEGER

MADE IN EU

Nr.	Spezifikation	
52119	29 cm	24



STRASSENBESEN MIT STIEL

MADE IN EU

Nr.	Spezifikation	
52197	30 cm 120 cm Holz	3



STRASSENBESEN

MADE IN EU

Nr.	Spezifikation	
52108	30 cm	Grobgewinde 25
61172	120 cm-Stiel	Grobgewinde 1



STRASSENBESEN MIT STIEL

Nr.	Spezifikation	
52135	145 cm 5x genäht	1



FESTA

STRASSENBESEN

Nr.	Spezifikation	
45323	37 cm	16





STRASSENBESEN



Nr.	Spezifikation	
52101	30 cm	10
52102	40 cm	10
52103	50 cm	10
52104	60 cm	10
52105	80 cm	10



STRASSENBESEN MIT STIEL



Nr.	Spezifikation	schaftlänge	
52190	30 cm	150 cm	3
52191	40 cm	150 cm	3
52192	50 cm	150 cm	3
52193	60 cm	150 cm	3
52194	80 cm	150 cm	3



HALLENBESEN



Nr.	Spezifikation	
52160	40 cm	10
52161	50 cm	10
52162	60 cm	10
52163	70 cm	10
52164	80 cm	10



HALLENBESEN MIT STIEL



Nr.	Spezifikation	schaftlänge	
52185	40 cm	150 cm	3
52186	50 cm	150 cm	3
52187	60 cm	150 cm	3
52188	70 cm	150 cm	3
52189	80 cm	150 cm	3



BESEN



Nr.	Spezifikation	
52114	28 cm Grobgewinde	1



BESEN MIT STIEL



Nr.	Spezifikation	schaftlänge	
52116	28 cm	130 cm-Stiel	3



BESEN



Nr.	Spezifikation	
52113	30 cm Grobgewinde	26
52115	30 cm ohne Gewinde	26



BESEN MIT STIEL



Nr.	Spezifikation	schaftlänge	
52195	30 cm	150 cm hölzern	3
52196	30 cm	130 cm ALU	3



SPACHTEL MIT GUMMI

Nr.	Spezifikation	
15886	450 mm Stiel Ø 23 mm	48
15887	600 mm Stiel Ø 23 mm	48
15888	750 mm Stiel Ø 23 mm	32



STRASSENBESEN MIT STIEL



Nr.	Spezifikation	
52109	25 cm 120 cm Holz	12





FESTA
STAHLBÜRSTE

Nr.	Spezifikation	
22135	6 x 19 cm ohne Stiel	8
22137	6 x 19 cm mit Stiel 140 cm MOQ	3

FESTA
NYLONBÜRSTE

Nr.	Spezifikation	
22136	6 x 19 cm ohne Stiel	8
22138	6 x 19 cm mit Stiel 140 cm MOQ	3



REINIGUNGSMOPP

Nr.	Spezifikation	
52110	30 cm	16



ERSATZMOPP

Nr.	Spezifikation	
52111	30 cm	1



FESTA
ALUMINIUMSTIEL

Nr.	Spezifikation	
45330	161 cm	24
45331	100 cm	24



BESENSTIEL

Nr.	Spezifikation	
52126	130 cm, Grobgewinde	1



BESENSTIEL

Nr.	Spezifikation	
61172	120 cm Holzstiel mit Grobgewinde	1
61192	150 cm Holzstiel für 52195	1
61193	150 cm Holzstiel für 52185 - 94	1
61194	140 cm Holzstiel mit Grobgewinde	1

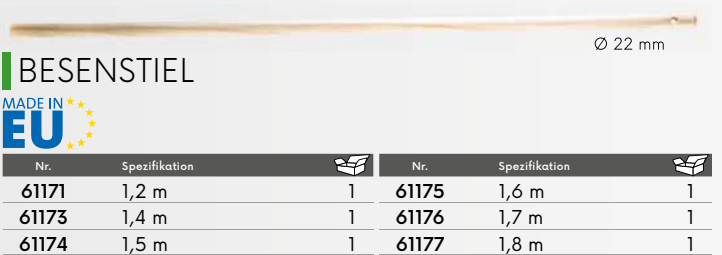

BESENSTIEL

Nr.	Spezifikation		Nr.	Spezifikation	
61171	1,2 m	1	61175	1,6 m	1
61173	1,4 m	1	61176	1,7 m	1
61174	1,5 m	1	61177	1,8 m	1

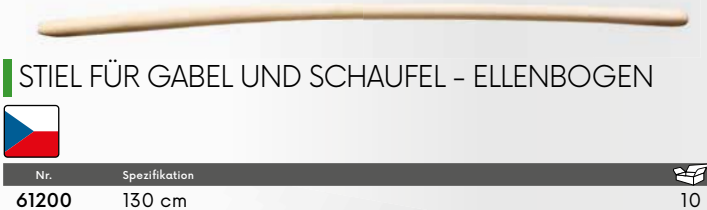

STIEL FÜR GABEL UND SCHAUFEL - ELLENBOGEN

Nr.	Spezifikation	
61200	130 cm	10

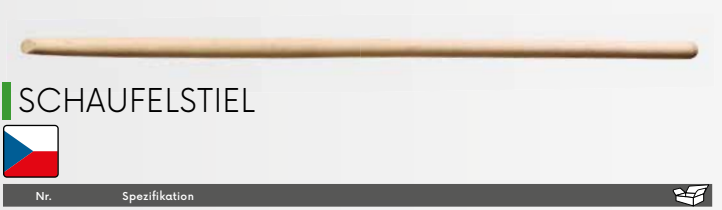

SCHAUFELSTIEL

Nr.	Spezifikation	
61201	130 cm, gerade	10



SPATENSTIEL „T“

Nr.	Spezifikation	
61208	90 cm	10

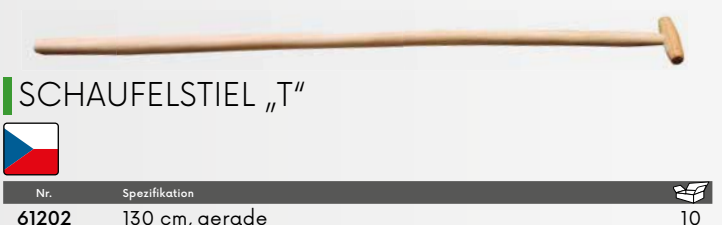

SCHAUFELSTIEL „T“

Nr.	Spezifikation	
61202	130 cm, gerade	10



STIEL FÜR KELLE



Nr.	Spezifikation	
61215	160 cm	10



SPITZHACKENSTIEL



Nr.	Spezifikation	
61204	95 cm, schmal (für 61120)	10
61205	95 cm	10



KUNSTSTOFFRECHENSTIEL



Nr.	Spezifikation	
61195	120 cm	10



RECHENSTIEL



Nr.	Spezifikation	vhodné pro	
61250	160 cm	45051, 61048	20
61251	160 cm	45052	20
61252	160 cm	45320	20
61253	160 cm	45053	20
61254	160 cm	45054	20
61255	160 cm	45070	20
61256	160 cm	45055	20



SPATENSTIEL „Y“



Nr.	Spezifikation	
61207	100 cm	10



HACKENSTIEL



Nr.	Spezifikation	
61219	120 cm	10

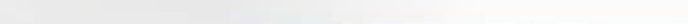

EISENRECHENSTIEL



Nr.	Spezifikation	
61183	150 cm	10
61184	160 cm	10
61189	170 cm	10
61190	180 cm	10



KUNSTSTOFFGRIFF „Y“ FÜR STIEL

Nr.	Spezifikation	
61230		10



Nr.	Spezifikation
61005	15
61006	15
61050	15
61051	15
61052	15
61079	1
61097	15
61098	15

61077



• Beispielfoto

WERBESTÄNDER FÜR SCHAUFELN UND SPATEN

Nr.	Spezifikation	
61077	Ständer montiert	1
61079	Ständer mit Palette	1

GARTENWERKZEUGHALTER

5x

Nr.	Spezifikation	
51184		12



rotierende Gummwalzen



GARTENWERKZEUGHALTER

Nr.	Spezifikation	
51185	45 cm	15



• Beispielfoto



INSEKTENSCHUTZGITTER

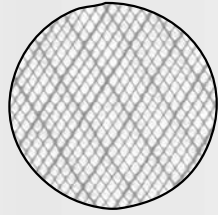

Nr.	Spezifikation	
40100	1 x 25 m - PE weiß	1
40120	1,2 x 25 m - PE weiß	1

INSEKTENSCHUTZGITTER

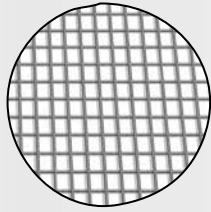

ALU Zn

Nr.	Spezifikation	
42101	1 x 30 m - ALUMINIUM	2
42103	1 x 30 m - galvanisierter Draht	2

INSEKTENSCHUTZGITTER

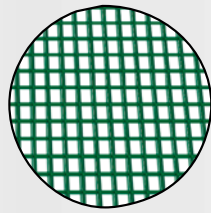

Nr.	Spezifikation	
42102	1 x 30 m - grün lackierter Stahldraht	2

INSEKTENSCHUTZGITTER
GLASFASER

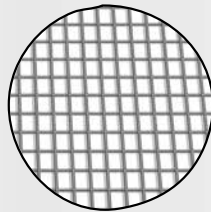

Nr.	Spezifikation		
41083	0,8 x 30 m weiß	6	
41103	1 x 30 m weiß	6	
41123	1,2 x 30 m weiß	6	
41153	1,5 x 30 m weiß	6	

Nr.	Spezifikation		
41082	0,8 x 30 m weiß-grau	6	
41102	1 x 30 m weiß-grau	6	
41122	1,2 x 30 m weiß-grau	6	
41152	1,5 x 30 m weiß-grau	6	

Nr.	Spezifikation		
41050	0,5 x 30 m grau	6	
41080	0,8 x 30 m grau	6	
41100	1 x 30 m grau	6	
41120	1,2 x 30 m grau	6	
41150	1,5 x 30 m grau	6	

Nr.	Spezifikation		
41081	0,8 x 30 m schwarz	6	
41101	1 x 30 m schwarz	6	
41121	1,2 x 30 m schwarz	6	
41151	1,5 x 30 m schwarz	6	





FENSTERNETZ MIT KLETTVER-SCHLUSS - WEISS



Nr.	Spezifikation		
40050	150 x 130 cm	5,6 m	10
40052	150 x 180 cm	6,6 m	10
40054	150 x 90 cm	4,8 m	10
40056	220 x 75 cm 2 stck	5,8 m	10

FENSTERNETZ MIT KLETTVER-SCHLUSS - GRAU



Nr.	Spezifikation		
40051	150 x 130 cm	5,6 m	10
40053	150 x 180 cm	6,6 m	10
40055	150 x 90 cm	4,8 m	10

FENSTERNETZ MIT KLETTVER-SCHLUSS - SCHWARZ



Nr.	Spezifikation		
40057	150 x 130 cm	5,6 m	10
40058	150 x 180 cm	6,6 m	10
40059	150 x 90 cm	4,8 m	10



KLETTVERSCHLUSS, SELBSTKLEBEND, FÜR FENSTERNETZE

Nr.	Spezifikation	
40060	9 mm 7 m	1



TÜRVORHANG GEGEN INSEKTEN MAGNETISCH - ANTHRAZIT



Nr.	Spezifikation	
40077	100 x 220 cm	1



TÜRSCHARNIER GEGEN INSEKTEN

· variable Abmessungen 60 - 120 cm

Nr.	Spezifikation		
40075	4 x 35 x 220 cm	weiß	20
40076	4 x 35 x 220 cm	schwarz	20

HEX-GEFLECHT

· vor dem Verflechten verzinkt

Zn



Nr.	Spezifikation	
42150	13 0,7 x 1000 mm - 50 m	1
42151	16 0,7 x 1000 mm - 50 m	1
42152	20 0,7 x 1000 mm - 50 m	1
42153	25 0,8 x 1000 mm - 50 m	1

HEX-GEFLECHT

Zn



Nr.	Spezifikation	
42155	13 0,7 x 1000 mm - 50 m	1
42156	16 0,7 x 1000 mm - 50 m	1
42157	20 0,7 x 1000 mm - 50 m	1
42158	25 0,8 x 1000 mm - 50 m	1

DRAHTGEFLECHT, QUADRATISCH

Zn



Nr.	Spezifikation	
42160	13 1 x 1000 mm - 25 m	1
42161	16 1 x 1000 mm - 25 m	1
42162	20 1 x 1000 mm - 25 m	1
42163	25 1 x 1000 mm - 25 m	1

DRAHTGEFLECHT, QUADRATISCH KUNSTSTOFFBESCHICHTET



Nr.	velikost oka	Ø drátu	výška	length	
42175	15 x 9 mm	2 mm	40 cm	25 m	1
42176	15 x 9 mm	2 mm	65 cm	25 m	1
42177	15 x 9 mm	2 mm	90 cm	25 m	1
42178	15 x 9 mm	2 mm	120 cm	25 m	1
42179	15 x 9 mm	2 mm	25 cm	25 m	1



SICHERHEITSNETZ

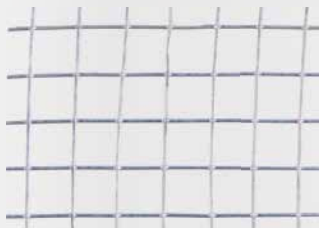

140 g/m² UV STABLE

Nr.	Spezifikation	
42185	6 0,65 x 1000 mm - 25 m	1
42170	10 0,8 x 1000 mm - 25 m	1
42171	13 0,8 x 1000 mm - 25 m	1
42172	16 1,2 x 1000 mm - 25 m	1
42173	19 1,4 x 1000 mm - 25 m	1

Nr.	Spezifikation	
42174	25 1,4 x 1000 mm - 25 m	1
42186	13 1,05 x 1000 mm - 25 m	1
42187	25 2,0 x 1000 mm - 25 m	1
42188	50 2,0 x 1000 mm - 25 m	1

ZIERDRAHTGEFLECHT, KUNSTSTOFF-BESCHICHTET



Nr.	Spezifikation	
42180	13 1,2 x 1000 mm - 25 m	1
42181	16 1,2 x 1000 mm - 25 m	1
42182	25 2,3 x 1000 mm - 25 m	1

VOGELSCHUTZGITTER



MADE IN EU

Nr.	Spezifikation	
45570	2 x 5 m 18 x 18 mm	45
45571	2 x 10 m 18 x 18 mm	28
45572	4 x 5 m 18 x 18 mm	24
45573	4 x 10 m 18 x 18 mm	15

SICHERHEITSNETZ

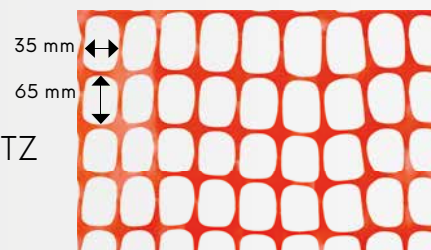

140 g/m² UV STABLE

Nr.	Spezifikation	
42190	1,2 x 50 m HDPE 140g/m ²	1

RABITZGEFLECHT

Zn



Nr.	Spezifikation	
42312	1 m 50 bm, 16 x 16 mm	1

VERBISSSCHUTZ FÜR BÄUME

· samosvorná



3x MADE IN EU

Nr.	Spezifikation	
45580	Ø 11 x 80 cm	1



BINDUNGSDRAHT

Zn

Nr.	Ø drátu	délka drátu	
42203	0,6 mm	30 m	50



BINDUNGSDRAHT

Nr.	Ø drátu	délka drátu	povrch	
42201	0,6 mm	30 m	PVC	50
42202	0,9 mm	30 m	PVC	50



STACHELDRAHT

Zn

Nr.	Ø drátu	délka drátu	
42260	1,7 mm	50 m	1
42261	1,7 mm	100 m	1



SPANNUNGSEINRICHTUNG

Nr.	Spezifikation	
50035	2 t	6
50036	4 t	4



ZAUNSPANNER, KLEIN

Zn

Nr.	Spezifikation	
50030	verzinkt, klein	50
50032	PVC, klein	50



BINDUNGSDRAHT

Zn

Nr.	Ø drátu	délka drátu	
42207	0,8 mm	50 m	40
42208	0,8 mm	100 m	20
42209	0,9 mm	100 m	20
42240	1,0 mm	50 m	40
42210	1,0 mm	100 m	20
42211	1,2 mm	50 m	40
42212	1,2 mm	100 m	20
42213	1,4 mm	30 m	40
42214	1,4 mm	50 m	20
42217	1,8 mm	30 m	40
42218	1,8 mm	50 m	20



BINDEDRAHT

Nr.	Ø drátu	délka drátu	
42244	1,4 mm	50 m	20
42248	1,8 mm	50 m	20
42249	2,0 mm	50 m	20



SPANNDRAHTKLEMME

INOX

Nr.	Spezifikation	
50040	Edelstahlspitze, grün	50
50041	Edelstahlspitze, schwarz	50



ZAUNSPANNER, GROSS

Zn

Nr.	Spezifikation	
50031	verzinkt	50
50033	PVC	50



SPANNDRAHT

Zn

Nr.	Ø drátu	délka drátu	
42219	2,0 mm	26 m	20
42220	2,0 mm	52 m	20
42221	2,0 mm	78 m	20
42228	3,15 mm	26 m	10
42229	3,15 mm	52 m	10
42230	3,15 mm	78 m	10



SPANNDRAHT

Nr.	Ø drátu	délka drátu	
42251	2,6 mm	26 m	20
42252	2,6 mm	52 m	20
42253	2,6 mm	78 m	20
42255	3,4 mm	26 m	10
42256	3,4 mm	52 m	10
42257	3,4 mm	78 m	10



SPANNDRAHTKLEMME

10x

Nr.	Spezifikation	
50042		10



ZAUNSPANNER, KLEIN LT

Zn

Nr.	Spezifikation	
50037	verzinkt	50
50038	PVC	50

PFOSTENANKERFUSS

Zn

Nr.	Spezifikation	tl.	
55436	70 x 75 mm	110 mm 4 mm	10
55437	80 x 90 mm	130 mm 4 mm	10



PFOSTENANKERFUSS

Zn

Nr.	Spezifikation	tl.	
55429	70 x 60 mm	100 mm 4 mm	10
55433	81 x 60 mm	100 mm 4 mm	10
55430	91 x 60 mm	100 mm 4 mm	10
55431	101 x 60 mm	100 mm 4 mm	10
55432	121 x 60 mm	100 mm 4 mm	10



SÄULENANKERFUSS EINSTELLBAR

Zn

Nr.	Spezifikation	tl.	
55465	80 - 160 x 70 mm	100 mm 4 mm	1

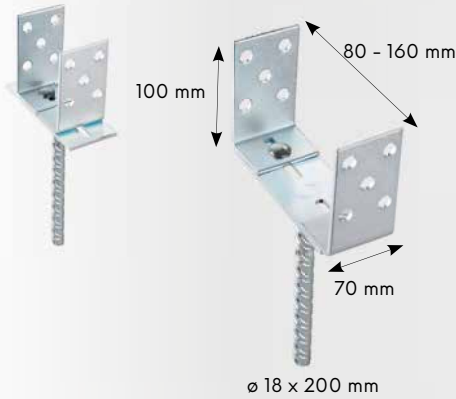

PFOSTENANKERFUSS

Zn

Nr.	Ø Füße	Fußlänge	Dicke des Materials	
55420	71 x 71 mm	150 mm	2 mm	1
55425	81 x 81 mm	150 mm	2 mm	1
55421	91 x 91 mm	150 mm	2 mm	1
55422	101 x 101 mm	150 mm	2 mm	1
55423	121 x 121 mm	150 mm	2 mm	1
55424	151 x 151 mm	150 mm	2 mm	1



SÄULENFUSS MIT STELLSCHRAUBE

Zn

Nr.	Ø Füße	Absatzhöhe	Gewinde	
55460	80 x 80 mm	150 mm	M16	10
55461	100 x 100 mm	150 mm	M16	10
55462	150 x 150 mm	150 mm	M24	10



ERDBOHRER

Nr.	Ø	A	B	
61299	110 mm	270 mm	1200 mm	1
61300	140 mm	270 mm	1200 mm	1
61301	170 mm	270 mm	1200 mm	1
61302	200 mm	270 mm	1200 mm	1



PFOSTENANKERFUSS

Zn

Nr.	Ø Füße	Fußlänge	Dicke des Materials	
55400	71 x 71 mm	750 mm	2 mm	1
55401	91 x 91 mm	750 mm	2 mm	1
55406	81 x 81 mm	750 mm	2 mm	1
55402	91 x 91 mm	900 mm	2 mm	1
55403	101 x 101 mm	900 mm	2 mm	1
55404	121 x 121 mm	900 mm	2 mm	1
55405	151 x 151 mm	900 mm	2 mm	1



BODENSCHRAUBE "U"

Zn

Nr.	Ø Füße	Fußlänge	Dicke des Materials	
55455	71 x 60 mm	100 mm	4 mm	1
55452	81 x 60 mm	100 mm	4 mm	1
55456	90 x 60 mm	100 mm	4 mm	1
55453	101 x 60 mm	100 mm	4 mm	1
55457	110 x 60 mm	100 mm	4 mm	1
55454	121 x 60 mm	100 mm	4 mm	1

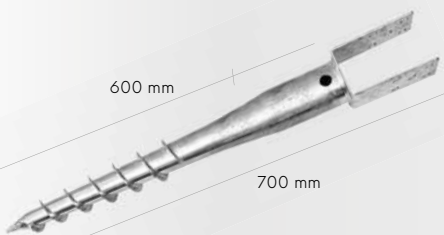

BODENSCHRAUBE

Reduktion

- Ø 24 mm
- Ø 35 mm
- Ø 40 mm
- Ø 48 mm
- Ø 55 mm

Zn 6x

Nr.	Ø Füße	Fußlänge	Spezifikation	
55450	60 mm	550 mm	1 stck + 5x Reduktion	8



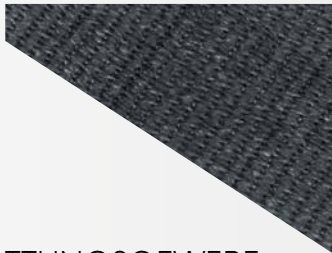

BESCHATTUNGSGEWEBE
HDPE 150 G/M2 ANTHRAZIT

· 85% Abschirmung

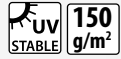

Nr.	Spezifikation	
45496	1 x 10 m	1
45497	1,5 x 10 m	1
45498	1,8 x 10 m	1
45499	2 x 10 m	1

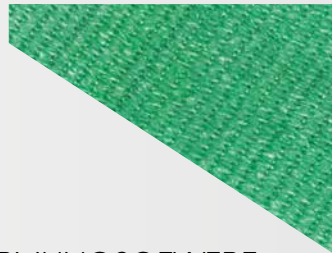

ABSCHIRMUNGSGEWEBE
HDPE 150 G/M2

· 85% Abschirmung

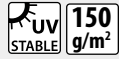

Nr.	Spezifikation	
45460	1 x 10 m	1
45461	1,5 x 10 m	1
45463	1,8 x 10 m	1
45462	2 x 10 m	1



ABSCHIRMUNGSGEWEBE
HDPE 220 G/M2

· 95% Abschirmung



Nr.	Spezifikation	
45465	1 x 10 m	1
45466	1,5 x 10 m	1
45467	2 x 10 m	1

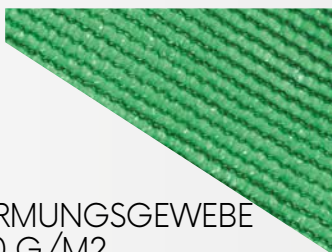

ABSCHIRMUNGSGEWEBE
HDPE 80 G/M2

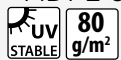

Nr.	Spezifikation	
45450	1 x 10 m	1
45451	1,5 x 10 m	1
45453	1,8 x 10 m	1
45452	2 x 10 m	1

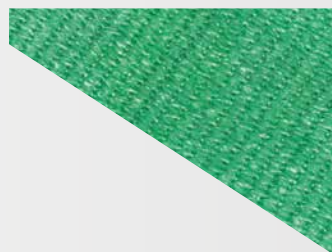

ABSCHIRMUNGSGEWEBE
HDPE 150 G/M2

· 85% Abschirmung



Nr.	Spezifikation	
45480	1,5 x 50 m	1



ABSCHIRMUNGSGEWEBE
HDPE 220 G/M2

· 95% Abschirmung

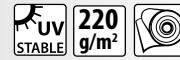

Nr.	Spezifikation	
45485	1,5 x 50 m	1



BINDUNGSBÄNDER

· EN 50146
· nylon



Nr.	Spezifikation	
23875	120 mm 4,8 mm	1



KLEMME FÜR BESCHATTUNGSGEWEBE



Nr.	Spezifikation	
45470		1





GRILLEN

INOX 18x

Nr.	Spezifikation
43077	



6



GRILLWERKZEUG-SET

INOX 3x

Nr.	Spezifikation
43071	380 mm



16



GRILLZANGE

INOX

Nr.	Spezifikation
43072	360 mm



25



GRILLSCHALE

4x

Nr.	Spezifikation
43050	300 x 200 mm

50



GRILLROST

Nr.	Spezifikation
43084	330 x 290 mm

50

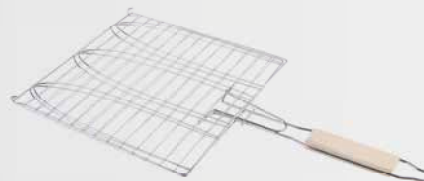

FISCHBRÄTER

Nr.	Spezifikation
43082	280 x 276 mm

50

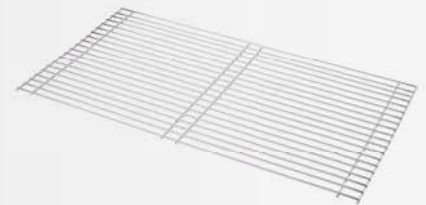

GRILLROST

Nr.	Spezifikation
43058	58 x 30 mm
43060	60 x 40 mm
43068	68 x 40 mm

20

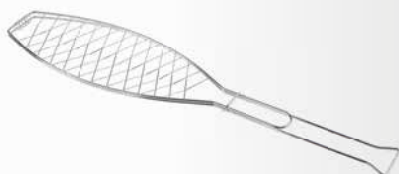

FISCHBRÄTER

Nr.	Spezifikation
43083	360 x 130 mm

12



SCHASCHLIKNADELN

4x

Nr.	Spezifikation
43086	Ø 3 x 380 mm

80



GRILLGABEL

Grillgabel mit Hygienezertifikat

Nr.	Spezifikation
43097	100 cm

100



GRILLGABEL - TELESKOPISCH



Nr. Spezifikation
43094

1



MECHANISCHES GEBLÄSE



Nr. Spezifikation
43087

1



2-IN-1-REINIGUNGSBÜRSTE

Nr. Spezifikation
43098 30 cm

10



3-IN-1-BÜRSTE

Nr. Spezifikation
43099

40



GRILLMOTOR 230V



Nr. Spezifikation
43090

24



AKKU-GRILLMOTOR
· batterie typ D



Nr. Spezifikation
43089

48



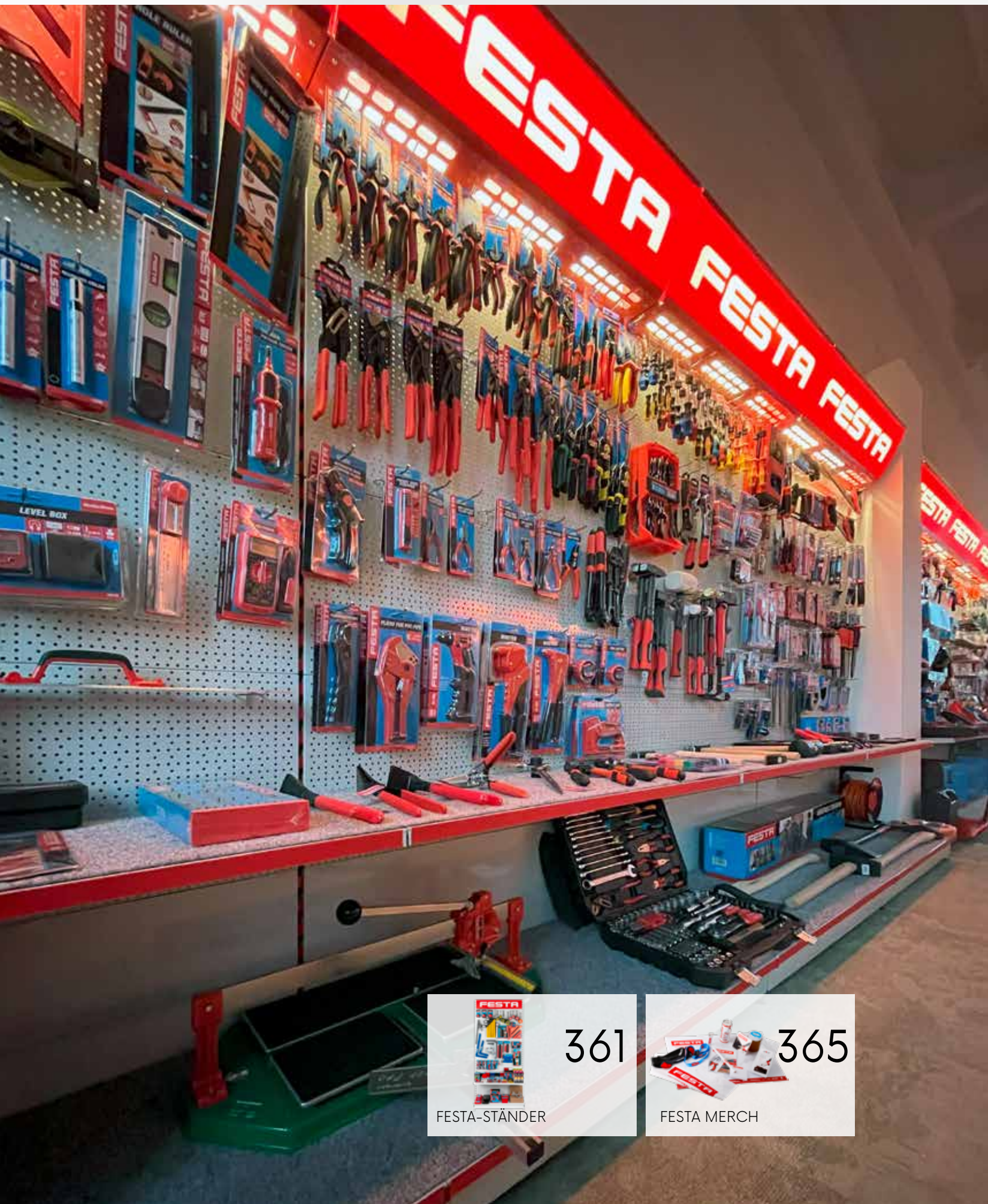

361

FESTA-STÄNDER



365

FESTA MERCH



 FESTA-STÄNDER GEFÜLLT

FESTA
LEUCHTKASTEN FÜR FESTA-STAND 81011

Nr.	Spezifikation	
81195	FESTA POWER TOOLS	1
81196	FESTA	1
81197	FESTA INDUSTRY	1



FESTA-STÄNDER + ZUBEHÖR



Nr.	Spezifikation	
81011	Ständer FESTA 220 x 100 cm	1
81011A	Ständer 81011 + Aufkleber AQUATIC	1
81011F	Ständer 81011 + Aufkleber FESTA CZ	1
81011G	Ständer 81011 + Aufkleber FESTA GB	1
81011H	Ständer 81011 + Aufkleber FESTA SK	1
81011R	Ständer 81011 + Aufkleber ROSA	1
81012	Regal FESTA 100 x 40 cm	8
81013	Haken 10 cm	10
81014	Haken 16 cm	10
81015	Haken 20 cm	10
81035	Haken mit Anhänger 20 cm	10
81016	Haken 30 cm	10
81036	Haken mit Anhänger 30 cm	10
81022	Glätterkorb - groß, 50 cm	1
81023	Glätterkorb - klein, 40 cm	1
81024	Trennwand zum Korb - groß, 50 cm	1
81025	Trennwand zum Korb - klein, 40 cm	1

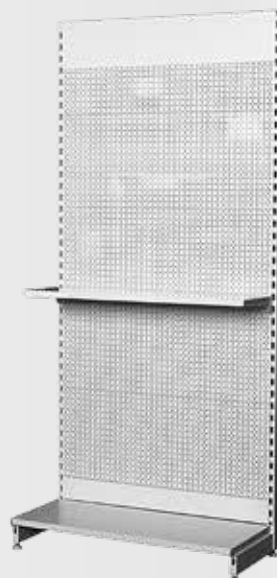



TRADE-KONSOLE

kompatibel mit dem FESTA Ständer

Nr.	Spezifikation	
81150	1000 x 50 x 135 mm	1
81151	1000 x 150 x 135 mm	1
81152	1000 x 350 x 135 mm	1

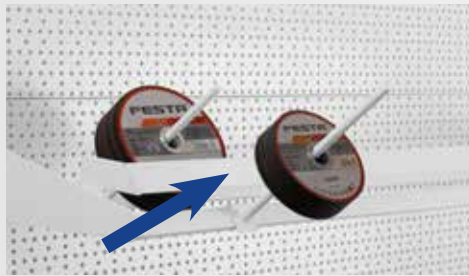

PREISLEISTENTRÄGER

kompatibel mit dem FESTA Ständer

Nr.	Spezifikation	
81155	1000 x 80 x 100 mm	1

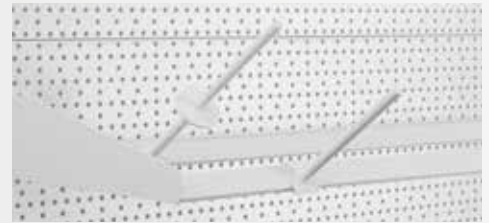

HAKEN FÜR TRENNSCHEIBEN

kompatibel mit dem FESTA Ständer

Nr.	Spezifikation	
81186	150 mm	1
81185	250 mm	1



RAHMEN FÜR TRENNSCHEIBEN

kompatibel mit dem FESTA Ständer

Nr.	Spezifikation	
81170	1000 x 450 x 85 mm	1



HALTER FÜR SÄGEN

kompatibel mit dem FESTA Ständer

Nr.	Spezifikation	
81190		1



HAKEN FÜR AKU-WERKZEUGE

kompatibel mit dem FESTA Ständer

Nr.	Spezifikation	
81189		1



REGAL FÜR SCHEIBEN

kompatibel mit dem FESTA Ständer

Nr.	Spezifikation	
81191	220 x 220 x 200 mm	1

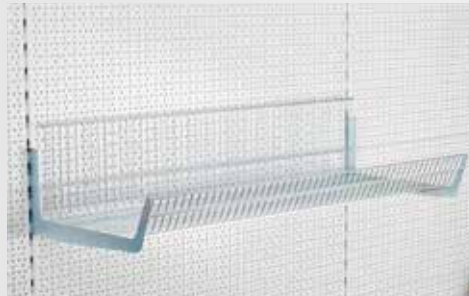

EINHÄNGEKORB

kompatibel mit dem FESTA Ständer

Nr.	Spezifikation	
81160	1000 x 470 x 180 mm	1



TRENNELEMENT

kompatibel mit dem FESTA Ständer

Nr.	Spezifikation	
81165	470 x 180 mm	1



HALTER FÜR HÄMMER UND SCHLÄGEL

Zn

kompatibel mit dem FESTA Ständer

Nr.	Spezifikation	
81188	max 2 kg	1



TRAPEZHAKEN, DOPPELT

kompatibel mit dem FESTA Ständer

Nr.	Spezifikation	
81175	120 mm	1
81178	180 mm	1

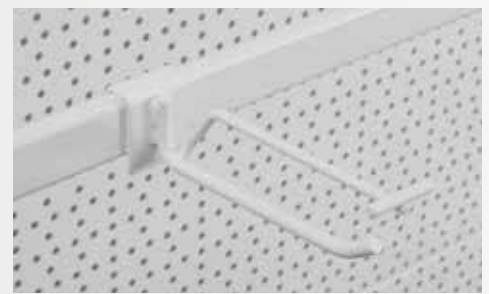

TRAPEZHAKEN, EINFACH

kompatibel mit dem FESTA Ständer

Nr.	Spezifikation	
81180	120 mm	1



Nr.	Spezifikation	
81200	Strebe 40/2400 mm verankert	1
81201	Steg 80/1108 mm	1
81202	Steg 80/1208 mm	1
81203	Steg 80/1408 mm	1
81204	Steg 80/1608 mm	1
81205	Steg 80/1808 mm	1
81206	Steg 80/2000 mm	1
81207	Steg 80/2108 mm	1
81208	Steg 80/2208 mm	1
81209	Steg 80/2308 mm	1
81210	Steg 80/2408 mm	1
81211	Steg 80/2600 mm	1
81212	Steg 60/1000 mm	1
81213	Steg 60/1208 mm	1
81214	Steg 60/1408 mm	1
81215	Steg 60/1608 mm	1
81216	Steg 60/1808 mm	1
81217	Steg 60/2108 mm	1
81218	Steg 60/2208 mm	1
81225	Strebe 30/2108 mm vorne	1
81486	Steg 60/2000 mm	1
81219	Stegverlängerung 80x30/100mm	1
81220	Stegverlängerung 80x30/400 mm	1
81221	Stegverlängerung 80x30/600 mm	1
81222	Stegverlängerung 60x30/400 mm	1
81223	EcSt.teg 90 Gr. 2100 mm	1
81224	EcSt.teg 90 Gr. 2200 mm	1
81226	Unterstützung 80	1
81227	Unterstützung 60	1
81228	Gondelkupplung mit Regal 80	1
81229	Ankerschiene	1
81230	Ankerhaken	1
81231	Verankerung leicht	1
81232	Verankerung oben	1
81233	Füllung 400	1
81234	Füllung 500	1
81235	Füllung 600	1
81236	Füllung 700	1
81237	Füllung 800	1
81238	Konsole, niedrig 200	1
81239	Konsole, niedrig 300	1
81240	Konsole, niedrig 400	1
81241	Konsole, niedrig 500	1
81242	Konsole, hoch 400	1
81243	Konsole, hoch 500	1
81244	Konsole, hoch 600	1
81245	Konsole, hoch 700	1
81246	Konsole, niedrig 300 doppelt	1
81247	Konsole, niedrig 400 doppelt	1
81248	Konsole, niedrig 300 doppelt	1
81251	Konsole RR 80	1
81249	Konsole, hoch doppelt 500	1
81250	Träger hohe Vitrine 400/2000	1
81252	Trogrfachteiler	1
81253	Trennelement niedrig 300	1
81254	Trennelement niedrig 400	1
81255	Trennelement niedrig 500	1
81256	Trennelement niedrig 300 Glas	1
81257	Trennelement niedrig 400 Glas	1
81258	Trennelement niedrig 500 Glas	1
81259	Trennelement hoch 300 Glas	1
81262	Trennelement hoch 300 Plexi	1
81263	Trennelement hoch 400 Plexi	1
81264	Trennelement hoch 500 Plexi	1
81260	Trennelement hoch 400 Glas	1
81261	Trennelement hoch 500 Glas	1
81265	Seitenwand hohe Vitrine 400/2000	1
81266	Dach-Seitenwände RR 80	1
81267	Seitenwand des Vorratsbehälters 500mm	1
81268	Seitenwand der Vitrine 500	1
81269	Träger der oberen Vitrine 500	1
81271	Regalseitenwand niedrig 300 Kunststoff	1
81272	Regalseitenwand niedrig 400 Kunststoff	1
81273	Regalseitenwand niedrig 500 Kunststoff	1
81274	Seitenwand hoch Glas 300/250	1
81275	Seitenwandschloss	1
81276	Seitenwand hoch Glas 500/250	1
81277	Regalseitenwand hoch 400	1
81278	Regalseitenwand hoch 500	1
81270	Dachträger RR 80	1
81279	Dachträger	1
81280	Dachseitenwand linSt.	1
81281	Dachseitenwand rechts	1
81282	Hängender Arm	1
81284	Arm doppelt 400/10	1
81285	Arm doppelt 300/8	1
81286	Arm einfach 350	1
81287	Arm einfach 500	1
81288	Arm einfach 250	1
81289	Aufhängung doppelt 100	1
81290	Aufhängung doppelt 200	1
81291	Aufhängung doppelt 300	1
81292	Aufhänger 130 V	1

Nr.	Spezifikation	
81293	Aufhängung, einfach 100	1
81294	Aufhängung, einfach 200	1
81295	Aufhängung, einfach 300	1
81296	Einzelhaken mit Reck 200	1
81297	Einzelhaken mit Reck 300	1
81298	Vitrinenschloss	1
81299	Drahttrennwand 360 mm hoch	1
81300	Drahttrennwand 460 mm hoch	1
81301	Drahttrennwand 560 mm hoch	1
81302	Trennwand 560 mm niedrig	1
81303	Konsole 300 doppelt L	1
81304	Konsole 300 doppelt R	1
81305	Konsole 400 doppelt L	1
81306	Konsole 400 doppelt R	1
81307	Konsole 500 doppelt L	1
81308	Konsole 500 doppelt R	1
81309	Regal Halbkreis 300	1
81310	Regal Halbkreis 400	1
81311	Regal Halbkreis 500	1
81312	Sockel Halbkreis 500	1
81313	Vorderseite des Sockels Halbkreis 500	1
81314	Preisschildhalter 300 Halbkreis	1
81315	Preisschildhalter 400 Halbkreis	1
81316	Preisschildhalter 500 Halbkreis	1
81317	Regal Halbkreis 600	1
81318	Sockel Halbkreis 600	1
81319	Stirnseite des Halbkreissockels 600	1
81320	Preisschild P 7,5x5 cm	1
81321	Preisschild P 2,6x3,2 cm	1
81322	Preisschild P 5,0x4,0 cm	1
81323	Perforiertes Regal 500/1000	1
81324	Strebenverbindung 80, Modul 1	1
81325	Rückwand 10x100cm	1
81326	Rückwand 20x100cm	1
81327	Rückwand 40x100cm	1
81328	Rückwand gelocht 20x100 cm EUR	1
81329	Rückwand gelocht 40x100 cm EUR	1
81330	Gondelabdeckung 8x100cm	1
81331	Gondelabdeckung 6x100cm	1
81332	Vorhangträger 100cm	1
81333	Glasregal 985/300 Vitrine	1
81334	Glasregal 985/400 Vitrine	1
81335	Holzregal 47/98,5	1
81336	Drahtregal 1000/500	1
81337	Muldenregal 1000x500	1
81338	Regal 200/1000	1
81339	Regal 300/1000	1
81340	Regal 400/1000	1
81341	Regal 500/1000	1
81342	Regal 400/1000 RAL7015	1
81343	Regal 500/1000 RAL7015	1
81347	Rahmen der hohen Vitrine 1000/400	1
81348	Rahmenglas der hohen Vitrine 1000/400	1
81349	Schubladeneinsatz, für Regal	1
81350	Abgehängte Decke des Metallregals 500/100	1
81352	Frontabstützung, hoch, 1000 mm, Glas	1
81353	Frontabschätzung, hoch, Plexiglas	1
81354	Frontabstützung, niedrig 1000 mm, Kunststoff	1
81355	Preisschildleiste, 1000 mm	1
81356	Kamm der Regalschubblende	1
81351	Kamm für hohe Trennwände, 1000	1
81357	Kamm, 1000 mm	1
81403	Kamm für hohe Trennelemente, 1250 mm	1
81420	Kamm für hohe Trennelemente, 625 mm	1
81358	Doppelte Nuten in der Vitrinentür	1
81359	Preisschildhalter, 1000 mm	1
81360	Tür hohe Vitrine 1000/2000	1
81361	Dachstirn, 1000 mm	1
81362	Eindeckungsplatte, 1000mm	1
81363	Tür des Vorratsbehälters	1
81364	Verschiebbare Vitrinentür	1
81365	Vitrinenspiegel	1
81366	Aufhängerahmen, Modul 1	1
81367	Vorhangstange	1
81370	Schräggestellter Drahtkorb	1
81371	Theke mit Vollplatte 1000 mm	1
81372	Thekensockel SU 5 1000mm	1
81373	Glastheke 1000 mm	1
81374	Theke mit Edelstahlplatte 1000 mm	1
81375	Theke mit Vollplatte 600 mm	1
81376	Regal für Theke 600 mm	1
81377	Glastheke 600 mm	1
81378	Regal für Theke 1000 mm	1
81379	Thekenregal, lang	1
81380	Thekensegment, hoch 90 Grad	1
81381	Doppelnut der Theke, 1000mm, Paar	1
81382	Schiebetür, Theke 1000mm, Paar	1
81383	Schubfach unter Platte	1
81384	Drahtregal RDE 1000/360 mm	1
81385	Drahtregal RDE 1000/460 mm	1
81386	Drahtregal RDE 1000/560 mm	1
81387	RDE Preisschildleiste 1000 mm	1
81388	Rückwand 100/1250 mm voll	1

Nr.	Spezifikation	
81389	Rückwand 200/1250 mm voll	1
81390	Rückwand 400/1250 mm voll	1
81391	Rückwand 200/1250 mm gelocht	1
81393	Gondelabdeckung 80/1250 mm	1
81392	Rückwand 400/1250 mm gelocht	1
81394	Gondelabdeckung 60/1250 mm	1
81395	Vorhangträger 1250 mm	1
81396	Regal 200/1250 mm	1
81439	Vorhangträger 1000 mm	1
81344	Regal 300/1000 verstärkt	1
81345	Regal 400/1000 verstärkt	1
81346	Regal 500/1000 verstärkt	1
81397	Regal 300/1250 mm	1
81400	Regal 300/1250mm, verstärkt	1
81401	Regal 400/1250mm, verstärkt	1
81402	Regal 500/1250mm, verstärkt	1
81398	Regal 400/1250 mm	1
81399	Regal 500/1250 mm	1
81404	Frontabstützung, niedrig 1250mm, Kunststoff weiß	1
81405	Preisschildleiste, 1250 mm	1
81406	Kamm 1250 mm	1
81407	Preisschildhalter, 1250 mm	1
81408	Dachstirn, 1250 mm	1
81409	Eindeckungsplatte, 600x1250mm	1
81410	Rückwand 100/625 voll	1
81411	Rückwand 200/625 voll	1
81412	Rückwand 400/625 voll	1
81413	Rückwand 400/625 gelocht	1
81414	Gondelabdeckung 80/650	1
81415	Gondelabdeckung 60/650	1
81416	Vorhangträger, Modul 3	1
81432	Vorhangträger, 1330mm	1
81417	Regal 300/625	1
81418	Regal 400/625	1
81419	Regal 500/625	1
81421	Frontabstützung, niedrig 625, Kunststoff weiß	1
81422	Preisschildleiste 625mm	1
81423	Kamm 625 mm	1
81424	Preisschildhalter, 625 mm	1
81425	Rückwand 100/1330 voll	1
81457	Frontabstützung, niedrig 200 Kunststoff	1
81426	Rückwand 200/1330 voll	1
81427	Rückwand 400/1330 voll	1
81428	Rückwand 200/1330 gelocht S	1
81429	Rückwand 400/1330 gelocht S	1
81430	Gondelabdeckung 80/1330	1
81431	Gondelabdeckung 60/1330	1
81433	Regal 300/1330	1
81434	Regal 400/1330	1
81435	Regal 500/1330	1
81436	Preisschildleiste, 1330 mm	1
81437	Kamm 1330 mm	1
81438	Preisschildhalter 1330 mm	1
81440	Drahtregal - Korb	1
81441	Rückwand 100 eckig	1
81442	Rückwand 400 eckig	1
81443	Sockelfrontseite, eckig, 500/1000mm	1
81444	Sockelfrontseite, eckig, 600 mm	1
81445	Rückwand, eckig, 400mm perforiert	1
81447	Regal 300 eckig	1
81448	Regal 400 eckig	1
81449	Regal 500 eckig	1
81450	Regal 600 eckig	1
81451	Preisschildhalter 300 eckig	1
81452	Preisschildhalter 400 eckig	1
81453	Preisschildhalter 500 eckig	1
81454	Preisschildleiste 300 eckig	1
81455	Preisschildleiste 400 eckig	1
81456	Preisschildleiste 500 eckig	1
81458	Drahtregal Korb U 1000/400	1
81459	Drahtregal Korb U 1000/500	1
81460	Sockelfrontseite, eckig, 90 Grad.	1
81461	Rückwand eckig 100, Steg 60	1
81462	Rückwand eckig 200, Steg 60	1
81463	Rückwand eckig 400, Steg 80	1
81466	Rückwand eckig 100, Steg 80	1
81467	Rückwand eckig 400, Steg 60	1
81468	Regal eckig 90 Gr. 400 mm	1
81469	Regal eckig 90 Gr. 500 mm	1
81470	Preisschildhalter eckig 90 Gr. 400 mm	1
81471	Preisschildhalter eckig 90 Gr. 500 mm	1
81472	Preisschildhalter eckig 90 Gr. 400 mm	1
81473	Preisschildhalter eckig 90 Gr. 500 mm	1



KONSOLE WEISS

MOQ
2

Nr.	Spezifikation	
81100	100 x 75 mm	24
81101	125 x 100 mm	24
81102	150 x 125 mm	24
81103	200 x 150 mm	24
81104	250 x 200 mm	24
81105	300 x 250 mm	24
81106	350 x 300 mm	24



REGALSTREBE EINFACH

Nr.	Spezifikation	
81053	50 cm	10
81054	80 cm	10
81057	200 cm	10



REGALHAKEN EINFACH

Nr.	Spezifikation	
81070	10 cm	10
81071	15 cm	10
81077	50 cm	10



PAPIER-PRÄSENTATIONS-STÄNDER FÜR NIVELLIERSYSTEME



Nr.	Spezifikation	
37179	60 x 40 x 175 cm - ENG	1



PAPIER-PRÄSENTATIONS-STAND FESTA



Nr.	Spezifikation	
81602	60 x 40 x 175 cm - ENG	1

PAPIER-PRÄSENTATIONS-STÄNDER FESTA ELEKTROWERKZEUGE



Nr.	Spezifikation	
81603	60 x 40 x 175 cm	1



FESTA

WERBE-T-SHIRT ROT FESTA



Nr.	Spezifikation	
M90203	M	1
M90204	L	1
M90205	XL	1
M90206	XXL	1
M90207	XXXL	1

FESTA

WERBEBLOCK FESTA



Nr.	Spezifikation	
M90400		1



FESTA

WERBESTIFT FESTA



Nr.	Spezifikation	
M90403		1



FESTA

WERBUNG FÜR USB-KABEL FESTA



Nr.	Spezifikation	
M90519		1

FESTA

WERBESOCKEN FESTA



Nr.	Spezifikation	
M90220	39-41	1
M90221	42-44	1
M90222	45-47	1



FESTA

WERBEZÄHLER FESTA

MOQ 12

Nr.	Spezifikation	
11410	2 m x 16 mm	1



FESTA

WERBEKAPPE FESTA



Nr.	Spezifikation	
M90210		1

FESTA

WERBE-KLAPPMESSER FESTA



Nr.	Spezifikation	
16209		1



Nummer Artikel	S.	Nummer Artikel	S.	Nummer Artikel	S.	Nummer Artikel	S.	Nummer Artikel	S.	Nummer Artikel	S.
10002	96	11355	98	13249	121	13414	101	13509	99	14420	104
10003	96	11356	98	13250	121	13415	101	13510	99	14421	104
10005	96	11358	98	13251	121	13416	101	13511	99	14425	105
10008	96	11360	98	13252	121	13417	101	13512	99	14430	105
10025	96	11410	100	13253	121	13418	101	13513	99	14435	105
10033	96	11410	365	13254	121	13419	101	13514	99	14440	105
10035	96	11416	99	13255	121	13420	101	13515	99	14445	105
10043	96	11420	100	13256	121	13421	101	13516	99	14446	105
10045	96	11425	100	13257	121	13422	101	13517	99	14450	105
10048	96	11444	100	13258	121	13423	101	13518	99	14451	105
10110	96	11445	100	13259	121	13424	101	13519	99	14455	105
10120	96	12010	99	13260	120	13425	101	13520	99	14456	105
10130	96	12020	99	13261	117	13426	101	13521	99	14457	105
10330	96	12030	99	13262	117	13427	101	13522	99	14458	105
10332	96	12050	99	13263	117	13428	101	13523	99	14471	105
10334	96	12110	99	13264	116	13429	101	13524	99	14472	105
10336	96	12120	99	13265	116	13430	101	13525	99	14473	105
10430	97	12130	99	13266	116	13431	101	13526	99	14474	105
10450	97	12150	99	13267	117	13432	101	13527	99	14480	104
10490	97	12220	99	13268	116	13433	101	13528	99	14485	109
10996	97	12230	99	13269	116	13434	101	13529	99	14485	271
10998	97	12250	99	13270	116	13435	101	13530	99	14486	109
10999	97	12433	100	13271	116	13436	101	13531	99	14486	271
11002	99	12435	100	13272	116	13437	101	13532	99	14490	105
11003	99	13010	101	13273	116	13438	101	13533	99	14491	105
11005	99	13020	101	13274	116	13439	101	13534	99	14492	105
11006	99	13021	101	13275	116	13440	101	14001	102	14493	105
11007	99	13022	101	13276	117	13441	101	14002	102	14494	105
11008	99	13023	101	13277	120	13442	101	14003	102	15003	107
11082	99	13111	101	13278	116	13443	101	14004	102	15004	107
11083	99	13120	101	13279	117	13444	101	14006	102	15005	107
11085	99	13200	118	13280	117	13445	101	14007	102	15006	107
11102	98	13201	118	13281	102	13446	101	14008	102	15008	107
11103	98	13202	118	13282	102	13447	101	14009	102	15010	107
11105	98	13205	119	13284	117	13448	101	14010	103	15012	107
11106	98	13206	119	13285	102	13449	101	14011	103	15015	107
11107	98	13207	119	13288	117	13450	101	14012	103	15018	107
11110	98	13208	119	13290	217	13451	101	14013	102	15020	107
11200	99	13211	101	13293	217	13452	101	14015	103	15033	106
11201	99	13212	119	13294	217	13453	101	14017	103	15034	106
11202	99	13214	118	13295	120	13454	101	14019	103	15035	106
11204	99	13216	118	13296	120	13455	101	14025	105	15036	106
11205	99	13217	118	13350	121	13456	101	14030	103	15037	106
11206	99	13218	118	13351	121	13457	101	14035	102	15039	106
11207	99	13219	118	13352	121	13458	101	14040	102	15103	107
11208	99	13220	101	13353	121	13459	101	14045	102	15104	107
11209	99	13222	118	13354	121	13460	101	14060	103	15105	107
11210	99	13223	118	13355	121	13461	101	14070	103	15106	107
11220	98	13224	118	13360	121	13462	101	14075	103	15108	107
11221	98	13225	118	13361	121	13463	101	14077	103	15110	107
11226	98	13226	118	13362	121	13464	101	14080	102	15112	107
11239	98	13227	118	13363	121	13465	101	14090	104	15115	107
11259	98	13228	118	13364	121	13466	101	14091	104	15118	107
11260	98	13229	118	13365	121	13467	101	14220	105	15120	107
11311	100	13230	118	13399	101	13468	101	14225	105	15204	107
11312	100	13231	118	13400	101	13469	101	14230	105	15205	107
11313	100	13235	118	13401	101	13470	101	14235	105	15206	107
11314	100	13236	118	13402	101	13471	101	14240	105	15208	107
11323	98	13237	118	13403	101	13472	101	14250	105	15210	107
11325	98	13238	118	13404	101	13473	101	14350	105	15212	107
11327	98	13240	120	13405	101	13500	99	14360	105	15215	107
11333	98	13241	120	13406	101	13501	99	14370	105	15218	107
11335	98	13242	120	13407	101	13502	99	14380	105	15220	107
11337	98	13243	120	13408	101	13503	99	14399	105	15230	107
11338	98	13244	120	13409	101	13504	99	14410	105	15235	108
11343	98	13245	120	13410	101	13505	99	14411	105	15301	109
11345	98	13246	119	13411	101	13506	99	14415	104	15301	271
11347	98	13247	119	13412	101	13507	99	14417	104	15310	108
11353	98	13248	119	13413	101	13508	99	14418	104	15310	270

Nummer		Nummer		Nummer		Nummer		Nummer		Nummer	
Artikel	S.	Artikel	S.	Artikel	S.	Artikel	S.	Artikel	S.	Artikel	S.
15315	108	15810	109	16003	122	16075	130	16300	139	17037	137
15315	270	15810	271	16004	122	16077	130	16301	139	17038	177
15318	108	15812	109	16005	122	16078	130	16303	139	17039	176
15318	270	15812	271	16006	122	16081	130	16304	139	17040	174
15320	108	15815	109	16010	122	16082	129	16305	138	17041	174
15320	270	15815	271	16010	122	16083	131	16306	138	17042	174
15325	108	15818	109	16011	122	16084	131	16307	138	17043	174
15325	270	15818	271	16011	122	16085	126	16308	138	17044	174
15330	108	15820	109	16011	122	16086	126	16309	138	17045	174
15330	270	15820	271	16012	122	16087	127	16310	139	17046	177
15335	108	15825	109	16012	122	16090	125	16310	139	17047	172
15335	270	15825	271	16012	122	16091	125	16311	139	17048	177
15340	108	15830	109	16013	122	16095	127	16311	139	17049	177
15340	270	15830	271	16013	122	16099	124	16311	139	17050	139
15415	108	15850	109	16016	122	16100	124	16312	139	17050	181
15415	270	15850	271	16017	122	16105	124	16312	139	17051	177
15418	108	15853	109	16019	122	16110	124	16315	137	17052	177
15418	270	15853	271	16021	128	16115	124	16315	137	17053	177
15420	108	15855	109	16023	127	16120	124	16319	139	17054	177
15420	270	15855	271	16024	128	16125	124	16320	139	17055	177
15425	108	15860	109	16025	125	16130	126	16321	139	17056	177
15425	270	15860	271	16026	128	16131	124	16321	229	17057	177
15430	108	15870	109	16028	128	16135	126	16401	181	17058	177
15430	270	15870	271	16029	125	16136	125	16405	181	17059	176
15510	108	15880	109	16030	128	16137	125	16406	181	17060	176
15510	270	15880	271	16031	128	16140	126	16407	181	17061	176
15515	108	15885	256	16032	128	16141	128	16408	181	17062	176
15515	270	15886	256	16033	127	16142	125	16420	181	17063	175
15518	108	15886	349	16034	126	16143	125	16500	176	17064	175
15518	270	15887	256	16035	127	16144	125	16501	176	17065	175
15520	108	15887	349	16036	129	16145	125	16502	176	17066	175
15520	270	15888	256	16037	127	16146	125	16990	136	17067	175
15525	108	15888	349	16039	127	16147	126	16990	320	17068	175
15525	270	15889	256	16041	129	16150	125	16991	136	17069	175
15530	108	15893	109	16042	129	16151	125	16991	320	17070	175
15530	270	15893	271	16042	279	16198	131	16998	122	17071	175
15535	108	15894	109	16043	128	16199	131	16999	122	17072	175
15535	270	15894	271	16044	126	16201	132	17001	171	17075	175
15540	108	15895	109	16046	128	16202	173	17002	171	17076	175
15540	270	15895	271	16049	129	16205	173	17003	171	17077	175
15615	108	15904	111	16050	129	16206	173	17004	171	17078	177
15615	270	15906	111	16051	129	16208	173	17005	171	17079	176
15620	108	15908	111	16052	129	16209	133	17006	171	17080	176
15620	270	15910	111	16053	128	16209	365	17007	171	17081	176
15625	108	15912	111	16054	129	16210	132	17008	171	17082	176
15625	270	15915	111	16055	128	16211	132	17009	171	17083	178
15630	108	15920	111	16056	278	16212	132	17010	171	17084	176
15630	270	15954	111	16057	126	16218	133	17011	171	17085	176
15710	109	15956	111	16058	126	16219	133	17012	176	17086	176
15710	270	15958	111	16059	129	16220	133	17013	176	17087	172
15715	109	15960	111	16060	130	16221	133	17014	176	17089	178
15715	270	15962	111	16061	130	16222	133	17015	178	17090	178
15720	109	15965	111	16062	130	16223	133	17016	178	17091	178
15720	270	15970	111	16063	130	16224	134	17017	178	17092	178
15725	109	15980	111	16064	130	16225	132	17019	178	17093	178
15725	270	15981	111	16065	130	16226	134	17020	177	17094	171
15730	109	15983	100	16066	124	16227	134	17021	177	17095	171
15730	270	15985	100	16066	130	16228	134	17022	177	17096	171
15735	109	15988	100	16067	130	16229	132	17023	175	17097	171
15735	270	15989	100	16068	130	16230	132	17024	171	17098	171
15740	109	15990	111	16069	129	16231	132	17025	174	17099	171
15740	270	15991	111	16070	129	16231	135	17026	137	17100	171
15754	110	15992	111	16070	131	16232	134	17027	137	17101	169
15756	110	15993	111	16071	127	16232	174	17028	177	17102	169
15758	110	15996	110	16071	130	16234	132	17029	176	17103	169
15760	110	15997	110	16072	130	16235	133	17033	176	17104	169
15762	110	15998	110	16073	131	16236	133	17034	175	17105	169
15768	110	15999	110	16074	126	16281	127	17035	175	17108	171
15770	110	16002	122	16074	131	16282	127	17036	175	17109	175

Nummer Artikel	S.	Nummer Artikel	S.	Nummer Artikel	S.	Nummer Artikel	S.	Nummer Artikel	S.	Nummer Artikel	S.
17110	171	17238	156	17393	160	17528	165	17622	164	17831	159
17111	179	17240	158	17394	160	17532	166	17623	164	17832	159
17112	179	17241	158	17395	160	17533	166	17624	164	17835	159
17113	179	17242	158	17396	160	17534	166	17625	164	17836	159
17116	179	17243	158	17397	160	17539	165	17626	164	17837	159
17117	179	17244	158	17398	160	17548	164	17628	164	17838	159
17121	179	17245	155	17400	161	17549	164	17629	164	17839	159
17122	179	17247	153	17401	160	17550	164	17630	164	17840	159
17125	172	17250	161	17402	160	17551	164	17631	164	17841	159
17126	172	17255	161	17405	160	17552	164	17632	164	17842	159
17127	172	17259	153	17406	160	17553	164	17633	164	17843	159
17128	172	17260	153	17407	160	17554	164	17640	166	17844	159
17130	172	17261	167	17410	160	17555	164	17642	166	17845	159
17133	172	17262	167	17411	160	17556	164	17643	166	17846	159
17135	172	17292	158	17412	160	17557	164	17644	166	17847	159
17137	172	17294	158	17413	160	17558	164	17645	166	17848	159
17138	172	17295	158	17414	160	17559	164	17650	166	17849	159
17140	169	17296	158	17415	160	17560	164	17651	166	17850	159
17142	169	17297	158	17416	160	17561	164	17652	166	17851	159
17145	169	17298	158	17420	160	17562	164	17653	166	17852	159
17146	169	17299	158	17421	160	17563	164	17654	166	17853	159
17148	169	17300	178	17422	160	17564	164	17655	166	17854	159
17150	175	17301	178	17427	161	17565	164	17656	166	17855	159
17151	175	17302	178	17450	167	17566	164	17657	166	17856	159
17158	181	17303	178	17451	167	17567	164	17658	166	17860	159
17159	181	17304	178	17452	167	17568	164	17659	166	17861	159
17160	181	17305	178	17454	168	17569	164	17660	164	17862	159
17165	179	17306	178	17455	161	17570	164	17661	164	17863	159
17167	179	17308	159	17455	168	17571	164	17662	164	17864	159
17169	179	17309	159	17456	168	17572	164	17663	164	17865	159
17170	179	17310	159	17458	168	17573	164	17664	164	17866	159
17172	178	17311	159	17459	168	17574	164	17665	164	17867	159
17175	180	17312	159	17460	164	17575	164	17666	164	17868	159
17177	180	17313	159	17461	164	17576	164	17667	164	17869	159
17178	172	17314	159	17462	164	17577	164	17668	164	17870	159
17180	172	17315	159	17463	164	17578	164	17669	164	17871	159
17181	172	17316	159	17464	164	17579	164	17670	164	17872	159
17182	45	17317	159	17465	164	17580	164	17671	164	17873	159
17182	137	17318	159	17467	164	17581	164	17672	164	17874	159
17183	45	17319	159	17468	164	17582	164	17674	164	17875	159
17183	137	17320	159	17469	164	17583	164	17675	164	17876	159
17185	181	17321	159	17470	164	17584	164	17676	164	17877	159
17186	180	17322	159	17471	164	17585	164	17677	164	17878	159
17187	181	17324	159	17472	164	17586	164	17678	164	17879	159
17188	181	17327	159	17473	164	17587	164	17679	164	17880	159
17189	181	17330	159	17475	166	17589	164	17680	168	17881	159
17190	174	17332	159	17476	166	17590	164	17681	168	17882	159
17191	174	17333	159	17480	164	17591	164	17682	168	17883	159
17192	174	17334	159	17481	164	17592	164	17683	164	17884	159
17193	174	17338	167	17482	164	17593	164	17685	165	17885	159
17197	165	17341	178	17483	164	17600	167	17761	164	17886	159
17198	165	17342	178	17484	164	17601	167	17769	164	17887	159
17199	165	17350	162	17485	164	17603	167	17788	164	17888	159
17200	165	17351	162	17486	164	17605	164	17795	164	17889	159
17201	165	17352	162	17487	164	17606	164	17806	164	17890	159
17202	165	17353	162	17488	164	17607	164	17810	161	17891	159
17203	167	17357	162	17489	164	17608	164	17811	161	17892	159
17204	167	17359	162	17490	164	17609	164	17812	161	17895	159
17205	167	17361	162	17491	164	17610	164	17820	159	17896	159
17206	167	17380	161	17492	164	17611	164	17821	159	17897	159
17229	155	17381	161	17493	164	17612	164	17822	159	17898	159
17230	155	17382	160	17494	164	17613	164	17823	159	17904	159
17231	155	17383	160	17495	164	17614	164	17824	159	17905	159
17233	155	17384	160	17496	164	17615	164	17825	159	17907	159
17234	155	17385	160	17501	166	17616	164	17826	159	17910	159
17235	156	17386	160	17506	165	17617	164	17827	159	17914	159
17236	156	17390	160	17508	165	17619	165	17828	159	17916	159
17237	154	17391	160	17512	166	17620	166	17829	159	17922	159
17238	153	17392	160	17526	165	17621	166	17830	159	17924	159

Nummer		Nummer		Nummer		Nummer		Nummer		Nummer	
Artikel	S.	Artikel	S.	Artikel	S.	Artikel	S.	Artikel	S.	Artikel	S.
17926	159	18302	143	18498	163	18638	147	18828	148	18971	160
17930	159	18303	143	18499	163	18639	147	18829	148	18993	150
17934	159	18304	143	18500	163	18640	147	18830	148	18994	150
17935	159	18310	140	18501	162	18641	147	18831	148	19001	197
17943	159	18311	140	18508	163	18645	147	18832	148	19002	197
17944	159	18312	140	18510	162	18646	147	18835	148	19003	197
17970	148	18313	140	18511	162	18680	147	18836	148	19004	197
17971	148	18321	140	18512	162	18685	147	18837	148	19005	197
17972	148	18322	140	18513	162	18710	146	18838	148	19006	197
17973	148	18340	141	18514	162	18711	146	18839	148	19008	197
17974	148	18350	140	18515	162	18712	146	18840	148	19010	197
17975	148	18351	140	18516	162	18715	146	18841	148	19015	197
17976	148	18352	140	18518	162	18716	146	18842	148	19020	197
17980	148	18353	140	18519	162	18717	146	18843	148	19021	195
17981	148	18354	140	18520	162	18720	146	18844	148	19022	195
17982	148	18355	140	18521	162	18721	146	18845	148	19023	195
17983	148	18356	140	18522	162	18722	146	18846	148	19024	195
18062	142	18357	140	18523	162	18723	146	18847	148	19025	195
18063	142	18358	140	18524	162	18724	146	18850	148	19026	195
18064	142	18359	140	18527	162	18725	146	18851	148	19028	195
18065	142	18360	140	18567	162	18750	147	18852	148	19030	195
18066	142	18400	143	18572	162	18751	147	18853	148	19031	195
18067	142	18401	143	18575	162	18753	147	18855	148	19032	195
18070	142	18402	141	18576	162	18755	147	18856	148	19034	195
18071	142	18403	141	18577	162	18760	147	18860	148	19036	195
18072	142	18404	141	18578	162	18761	147	18861	148	19041	195
18075	142	18408	145	18579	162	18762	147	18862	148	19042	195
18076	142	18409	145	18580	162	18763	147	18863	148	19043	195
18077	142	18410	142	18581	162	18764	147	18864	148	19044	195
18080	142	18411	142	18582	162	18765	147	18865	148	19045	195
18081	142	18413	142	18583	162	18766	147	18866	148	19046	195
18082	142	18415	144	18584	162	18767	147	18867	148	19050	197
18083	142	18416	144	18585	162	18768	147	18868	148	19051	197
18084	142	18417	144	18587	162	18769	147	18869	148	19052	197
18085	142	18418	143	18588	162	18770	147	18870	148	19053	197
18086	142	18419	144	18589	162	18771	147	18871	148	19054	197
18087	142	18420	144	18593	162	18772	147	18872	148	19055	197
18088	142	18421	152	18600	149	18775	147	18873	148	19056	197
18089	142	18422	141	18601	149	18776	147	18874	148	19057	197
18090	142	18423	142	18602	149	18777	147	18900	151	19058	195
18091	142	18424	141	18603	158	18795	149	18901	151	19059	195
18092	142	18425	140	18604	161	18796	149	18905	151	19060	196
18101	143	18426	145	18605	149	18797	149	18906	151	19061	196
18102	143	18427	145	18607	149	18798	149	18907	152	19062	196
18103	143	18428	115	18608	144	18799	149	18908	151	19063	196
18104	143	18429	115	18609	150	18800	148	18909	151	19064	196
18105	143	18430	152	18610	150	18801	148	18910	145	19065	196
18106	143	18431	144	18611	150	18802	148	18915	152	19066	195
18107	143	18432	146	18612	150	18803	148	18920	160	19067	195
18108	143	18433	144	18613	150	18804	148	18921	160	19068	195
18110	143	18434	140	18614	150	18805	148	18922	160	19069	195
18113	140	18435	145	18615	150	18806	148	18925	160	19070	195
18114	140	18437	145	18618	150	18807	148	18926	160	19071	195
18115	140	18440	152	18619	149	18810	148	18927	160	19074	195
18116	140	18445	173	18619	161	18811	148	18928	160	19075	195
18118	140	18450	143	18620	147	18812	148	18929	160	19076	195
18120	140	18451	143	18621	147	18813	148	18930	160	19077	195
18124	140	18455	143	18623	147	18814	148	18931	160	19081	195
18125	140	18456	143	18625	147	18815	148	18934	160	19082	195
18201	143	18460	143	18627	147	18816	148	18939	160	19083	195
18202	143	18476	162	18628	147	18817	148	18948	160	19084	195
18203	143	18490	163	18630	147	18820	148	18950	160	19085	195
18204	143	18491	163	18631	147	18821	148	18951	160	19086	195
18210	140	18492	163	18632	147	18822	148	18954	160	19088	195
18211	140	18493	163	18633	147	18823	148	18955	160	19090	195
18212	140	18494	162	18634	147	18824	148	18956	160	19092	195
18215	140	18495	162	18635	147	18825	148	18960	160	19095	195
18216	140	18496	163	18636	147	18826	148	18961	160	19096	195
18301	143	18497	163	18637	147	18827	148	18963	160	19097	195

Nummer Artikel	S.	Nummer Artikel	S.	Nummer Artikel	S.	Nummer Artikel	S.	Nummer Artikel	S.	Nummer Artikel	S.
19098	195	19394	317	19473	202	19580	56	19643	56	19704	57
19100	196	19395	317	19474	202	19585	56	19644	56	19705	57
19106	195	19396	317	19477	202	19585	56	19645	56	19705	57
19108	195	19397	317	19478	202	19586	56	19645	56	19706	57
19109	195	19398	197	19480	202	19587	56	19646	56	19707	57
19110	200	19399	197	19481	202	19588	56	19647	56	19708	57
19115	44	19400	201	19483	202	19589	56	19648	56	19708	57
19115	197	19400	251	19485	201	19590	56	19649	56	19709	57
19124	196	19401	201	19486	201	19590	56	19650	56	19710	57
19136	196	19401	251	19487	201	19591	56	19650	56	19711	57
19148	196	19402	201	19490	135	19593	56	19651	56	19711	57
19149	196	19402	251	19491	135	19594	56	19652	56	19712	57
19150	196	19403	201	19492	135	19595	56	19653	56	19713	57
19151	196	19403	251	19493	135	19595	56	19654	56	19713	57
19202	198	19404	201	19494	135	19596	56	19655	56	19714	57
19208	199	19404	251	19495	135	19597	56	19656	56	19715	57
19209	199	19405	201	19496	135	19598	56	19657	56	19716	57
19211	199	19405	251	19497	135	19599	56	19658	56	19717	57
19245	198	19406	201	19498	135	19600	56	19659	56	19718	57
19246	198	19406	251	19499	135	19600	56	19660	56	19718	57
19247	198	19407	201	19501	135	19601	56	19661	56	19719	57
19248	198	19407	251	19502	135	19603	56	19662	56	19720	57
19249	198	19408	201	19510	134	19604	56	19663	56	19721	57
19251	199	19408	251	19515	134	19605	56	19664	56	19722	57
19252	199	19409	201	19520	134	19605	56	19665	56	19723	57
19253	199	19409	251	19530	56	19606	56	19669	56	19723	57
19254	199	19410	201	19530	56	19607	56	19670	57	19724	57
19255	199	19411	201	19535	56	19608	56	19671	57	19725	57
19265	199	19412	201	19535	56	19609	56	19672	57	19726	57
19270	199	19415	200	19536	56	19610	56	19673	57	19727	57
19271	199	19416	200	19537	56	19610	56	19673	57	19728	57
19272	199	19418	201	19538	56	19611	56	19674	57	19728	57
19281	199	19419	201	19539	56	19612	56	19675	57	19729	57
19290	199	19420	200	19540	56	19613	56	19676	57	19730	57
19293	199	19421	200	19540	56	19614	56	19677	57	19731	57
19294	199	19422	200	19543	56	19615	56	19678	57	19732	57
19295	199	19423	200	19544	56	19615	56	19678	57	19733	57
19297	199	19424	200	19545	56	19616	56	19679	57	19733	57
19301	316	19425	200	19545	56	19617	56	19680	57	19734	57
19303	196	19426	200	19550	56	19618	56	19681	57	19735	57
19306	317	19427	200	19550	56	19619	56	19682	57	19736	57
19308	317	19429	201	19552	56	19620	56	19683	57	19737	57
19310	317	19430	197	19552	56	19620	56	19683	57	19738	57
19312	317	19431	197	19554	56	19621	56	19684	57	19738	57
19314	317	19432	197	19555	56	19622	56	19685	57	19739	57
19326	316	19433	197	19555	56	19623	56	19686	57	19740	57
19328	316	19434	197	19557	56	19624	56	19687	57	19741	57
19330	316	19435	197	19558	56	19625	56	19688	57	19742	57
19332	316	19436	201	19559	56	19625	56	19688	57	19743	57
19333	316	19440	197	19560	56	19626	56	19689	57	19743	57
19335	316	19441	197	19560	56	19627	56	19690	57	19744	57
19337	316	19442	197	19562	56	19628	56	19691	57	19745	57
19340	316	19443	197	19562	56	19629	56	19692	57	19746	57
19370	317	19450	135	19564	56	19630	56	19693	57	19747	57
19371	317	19451	135	19565	56	19630	56	19693	57	19748	57
19374	317	19455	135	19565	56	19631	56	19694	57	19748	57
19380	316	19457	135	19567	56	19632	56	19695	57	19749	57
19381	316	19458	135	19568	56	19633	56	19695	57	19750	57
19382	316	19459	135	19568	56	19634	56	19696	57	19751	57
19383	316	19460	201	19570	56	19635	56	19697	57	19752	57
19384	316	19460	251	19570	56	19635	56	19698	57	19753	57
19385	316	19462	317	19574	56	19636	56	19698	57	19753	57
19387	316	19463	317	19575	56	19637	56	19699	57	19754	57
19388	316	19464	317	19575	56	19638	56	19700	57	19755	57
19389	316	19465	317	19576	56	19639	56	19701	57	19756	57
19390	316	19469	317	19577	56	19640	56	19701	57	19757	57
19391	316	19470	201	19578	56	19640	56	19702	57	19758	57
19392	316	19470	251	19579	56	19641	56	19703	57	19758	57
19393	317	19472	202	19580	56	19642	56	19703	57	19759	57

Nummer Artikel	S.	Nummer Artikel	S.	Nummer Artikel	S.	Nummer Artikel	S.	Nummer Artikel	S.	Nummer Artikel	S.
19760	57	20300	59	20489	61	20751	67	20896	63	21110	75
19761	57	20305	59	20490	61	20752	67	20897	63	21111	75
19762	57	20310	59	20491	61	20753	67	20898	63	21112	75
19763	57	20311	59	20492	61	20754	67	20899	63	21115	75
19763	57	20315	60	20493	61	20755	67	20901	64	21118	75
19764	57	20316	59	20494	61	20756	67	20905	64	21123	75
19765	57	20317	59	20495	61	20757	67	20910	64	21130	75
19766	57	20320	60	20496	61	20758	67	20911	63	21135	75
19767	57	20321	60	20508	67	20759	67	20912	63	21140	75
19768	57	20333	58	20510	67	20760	67	20913	63	21150	75
19768	57	20334	58	20511	67	20761	67	20915	63	21180	75
19769	57	20335	58	20512	67	20762	67	20916	63	21190	75
19770	57	20336	58	20513	67	20764	67	20917	63	21192	77
19771	57	20337	58	20514	67	20765	67	20918	63	21194	77
19772	57	20338	58	20515	67	20766	67	20919	63	21195	75
19772	57	20340	60	20516	67	20767	67	20920	63	21200	74
19773	57	20350	202	20520	67	20768	67	20921	63	21201	74
19774	57	20360	139	20521	67	20769	67	20922	63	21203	74
19775	57	20361	139	20522	67	20770	67	20923	63	21204	74
19776	57	20363	180	20523	67	20771	67	20924	63	21205	74
19776	57	20364	180	20524	67	20772	67	20932	69	21209	74
19777	57	20365	29	20525	67	20773	67	20936	69	21210	75
19778	57	20379	29	20526	67	20774	67	20937	69	21211	75
19779	57	20380	60	20673	67	20775	67	20938	69	21212	75
19780	57	20381	64	20674	67	20776	67	20939	69	21215	75
19781	57	20385	62	20675	67	20777	67	20940	69	21218	75
19781	57	20386	62	20676	67	20778	67	20941	69	21219	75
19782	57	20387	62	20677	67	20779	67	20942	69	21220	75
19783	57	20390	62	20678	67	20780	67	20943	69	21223	75
19783	57	20391	62	20680	67	20781	67	20944	69	21224	75
19784	57	20394	62	20682	67	20782	67	20945	69	21230	74
19785	57	20395	62	20684	67	20783	67	20946	69	21231	74
19786	57	20396	62	20685	67	20784	67	20947	69	21234	74
19786	57	20397	62	20686	67	20785	67	20948	69	21235	74
19787	57	20400	58	20687	67	20786	67	20949	69	21238	74
19788	57	20401	58	20688	67	20787	67	20950	68	21301	75
19789	57	20402	58	20690	67	20788	67	20952	68	21303	75
19790	57	20403	58	20691	67	20789	67	20954	68	21306	77
19791	57	20404	58	20692	67	20790	67	20956	69	21308	77
19792	57	20405	58	20694	67	20791	67	20957	63	21311	75
19793	57	20406	58	20696	67	20792	67	20958	63	21312	75
19794	57	20407	58	20697	67	20793	67	20960	29	21315	75
19795	57	20408	58	20698	67	20794	67	20961	29	21318	75
19796	57	20409	58	20724	63	20795	67	20963	29	21323	75
19797	57	20410	58	20725	63	20796	67	20965	29	21324	75
19798	57	20411	58	20726	63	20797	67	20966	29	21326	75
19799	57	20412	58	20727	63	20798	67	20967	166	21327	75
19800	57	20413	58	20728	63	20799	67	20968	166	21411	75
19801	57	20414	58	20729	63	20805	68	20970	202	21412	75
19802	57	20415	58	20730	63	20820	68	20971	202	21415	75
19841	58	20416	58	20731	63	20825	67	20972	202	21418	75
19842	58	20417	58	20732	63	20855	67	20973	202	21423	75
19845	58	20418	58	20733	63	20861	67	20980	63	21424	75
19885	58	20419	58	20734	63	20862	67	20981	63	21425	76
19895	58	20420	58	20735	63	20870	67	20982	63	21426	76
20210	64	20421	58	20736	63	20871	67	20983	63	21427	76
20220	57	20422	58	20737	63	20872	67	20984	63	21428	76
20225	57	20423	58	20738	63	20873	67	20990	69	21430	76
20230	57	20424	58	20739	63	20874	67	20991	69	21431	76
20235	57	20425	58	20740	63	20875	67	20992	69	21432	76
20240	57	20426	58	20741	63	20876	67	20996	68	21435	76
20245	57	20427	58	20742	150	20877	67	20997	69	21436	76
20250	57	20428	58	20743	29	20878	67	20999	68	21437	76
20255	57	20429	58	20743	149	20879	67	21010	75	21440	64
20260	57	20430	58	20744	29	20880	67	21011	75	21441	64
20270	57	20450	64	20745	29	20881	67	21012	75	21442	64
20280	57	20460	64	20748	67	20890	68	21015	75	21443	64
20290	57	20487	61	20749	67	20891	68	21018	75	21444	64
20296	57	20488	61	20750	67	20895	68	21023	75	21445	64

Nummer Artikel	S.	Nummer Artikel	S.	Nummer Artikel	S.	Nummer Artikel	S.	Nummer Artikel	S.	Nummer Artikel	S.
21446	64	21803	78	22012	81	22083	82	22170	189	22277	76
21450	66	21804	78	22013	81	22084	82	22171	189	22280	76
21451	66	21805	78	22014	81	22085	82	22172	189	22281	76
21452	66	21806	78	22015	81	22086	187	22173	189	22285	76
21453	66	21807	65	22016	81	22087	83	22174	189	22286	76
21454	66	21807	78	22017	81	22088	82	22178	188	22294	76
21530	64	21808	65	22018	81	22090	82	22180	188	22300	86
21531	63	21808	78	22019	81	22091	83	22181	188	22301	86
21532	63	21809	79	22020	81	22092	83	22182	188	22302	86
21533	63	21810	84	22021	81	22093	83	22183	188	22303	86
21534	63	21811	84	22022	81	22095	82	22184	188	22305	86
21535	63	21812	84	22023	81	22096	84	22185	188	22307	86
21536	63	21813	84	22024	81	22097	84	22186	188	22309	86
21540	66	21814	84	22025	81	22098	84	22188	189	22310	86
21541	66	21831	84	22026	81	22099	84	22189	189	22311	86
21701	84	21832	84	22027	81	22100	85	22190	189	22312	86
21702	84	21834	84	22028	81	22101	85	22196	189	22313	86
21703	84	21850	85	22029	81	22102	85	22197	189	22314	86
21704	84	21851	85	22030	81	22103	85	22198	189	22315	86
21705	84	21852	85	22031	81	22104	85	22199	189	22316	86
21706	84	21853	85	22032	82	22105	85	22200	70	22317	86
21709	84	21854	85	22033	187	22106	85	22201	70	22318	86
21715	84	21855	85	22034	187	22107	85	22202	189	22319	86
21716	84	21856	85	22035	187	22108	85	22203	189	22320	86
21717	84	21857	85	22036	187	22109	85	22204	189	22322	86
21718	84	21858	85	22037	80	22110	85	22205	189	22324	86
21719	84	21859	85	22038	80	22111	85	22206	188	22326	86
21720	84	21860	85	22039	81	22112	85	22207	188	22328	86
21721	84	21861	85	22040	81	22113	85	22208	188	22329	86
21724	84	21862	85	22041	83	22115	85	22209	188	22332	86
21732	84	21863	85	22042	83	22116	85	22211	77	22333	86
21734	84	21864	85	22043	83	22117	85	22212	77	22335	86
21735	84	21900	80	22044	83	22119	85	22215	77	22337	86
21736	84	21901	80	22045	84	22120	293	22216	77	22340	86
21737	84	21902	80	22046	84	22121	293	22217	77	22343	86
21740	84	21903	80	22047	84	22122	293	22218	77	22345	86
21741	84	21904	80	22048	84	22123	293	22219	77	22350	86
21742	84	21905	80	22049	84	22124	293	22220	77	22351	86
21743	84	21906	80	22050	84	22125	293	22222	77	22355	86
21744	84	21907	80	22051	84	22126	293	22224	77	22357	86
21750	84	21908	80	22052	84	22129	293	22225	77	22365	86
21751	84	21909	81	22053	84	22130	293	22228	77	22370	86
21752	84	21910	81	22054	84	22132	293	22229	77	22398	86
21753	84	21911	80	22055	84	22133	293	22230	77	22399	86
21754	84	21912	80	22056	84	22134	293	22232	77	22510	56
21760	79	21913	80	22057	84	22135	350	22234	77	22515	56
21761	79	21914	80	22058	81	22136	350	22236	77	22520	56
21762	79	21920	80	22059	81	22137	350	22238	77	22525	56
21763	79	21925	80	22060	83	22138	350	22240	77	22530	56
21764	79	21926	80	22061	83	22140	79	22242	77	22532	56
21780	79	21930	82	22062	83	22141	79	22244	77	22535	56
21781	79	21931	82	22063	83	22142	79	22246	77	22540	56
21782	79	21935	82	22064	83	22143	79	22248	77	22542	56
21783	79	21936	82	22065	83	22145	79	22251	77	22545	56
21784	79	21937	82	22066	83	22146	79	22252	77	22548	56
21786	79	21940	82	22067	85	22147	79	22253	77	22550	56
21787	79	21941	82	22070	83	22148	79	22254	77	22555	56
21788	79	21950	81	22071	83	22150	79	22255	77	22560	56
21789	79	22001	80	22072	83	22151	79	22258	76	22565	56
21790	79	22002	80	22073	83	22155	79	22259	76	22568	56
21792	79	22003	80	22074	83	22156	79	22260	76	22570	56
21793	79	22004	80	22075	85	22158	187	22263	76	22575	56
21794	79	22005	80	22076	85	22159	187	22264	76	22580	56
21795	79	22006	80	22077	85	22160	83	22266	76	22585	56
21796	79	22007	80	22078	187	22161	83	22269	76	22590	56
21798	79	22008	80	22079	187	22162	83	22270	76	22595	56
21800	78	22009	80	22080	187	22163	83	22273	76	22600	56
21801	78	22010	80	22081	187	22164	83	22274	76	22602	56
21802	78	22011	80	22082	187	22167	83	22275	76	22605	56

Nummer Artikel	S.	Nummer Artikel	S.	Nummer Artikel	S.	Nummer Artikel	S.	Nummer Artikel	S.	Nummer Artikel	S.
22610	56	23658	209	23973	183	24111	190	24197	93	24676	72
22615	56	23660	210	23974	183	24114	191	24301	90	24677	72
22620	56	23661	209	23975	183	24115	191	24302	90	24678	72
22625	56	23664	209	23976	183	24118	93	24303	90	24680	276
22630	56	23670	203	23977	183	24119	93	24304	90	24690	202
22701	82	23671	203	23978	183	24120	93	24305	90	24691	202
22702	82	23672	203	23979	183	24121	190	24306	90	24695	202
22703	82	23673	203	23985	183	24122	190	24308	90	24700	72
22704	82	23674	203	23986	183	24124	190	24310	90	24701	72
22705	82	23675	203	23987	183	24125	190	24312	91	24702	72
22706	82	23676	203	23988	183	24126	190	24313	91	24703	72
22707	82	23677	203	23989	183	24128	193	24314	91	24704	72
23270	239	23678	203	24000	183	24130	192	24315	91	24705	72
23400	212	23679	203	24001	183	24131	192	24316	91	24706	65
23401	212	23680	203	24005	183	24132	134	24320	87	24710	73
23402	212	23681	203	24007	182	24133	192	24321	87	24712	65
23406	212	23682	203	24008	183	24134	191	24322	87	24713	65
23407	212	23683	203	24010	182	24135	192	24325	91	24714	65
23410	212	23684	203	24015	182	24136	192	24410	60	24715	65
23411	212	23685	203	24017	182	24137	192	24411	60	24716	65
23412	212	23730	168	24020	182	24140	192	24412	60	24717	69
23415	212	23731	168	24030	182	24141	192	24415	65	24718	69
23416	212	23732	168	24035	183	24142	192	24419	60	24719	69
23417	212	23734	168	24036	183	24143	191	24420	60	24720	65
23420	205	23735	168	24038	183	24144	191	24422	60	24721	65
23506	204	23736	168	24039	183	24145	191	24425	60	24722	65
23507	204	23760	185	24040	183	24147	191	24429	60	24723	69
23508	204	23761	185	24041	183	24148	192	24432	60	24725	70
23515	204	23762	185	24042	183	24149	191	24435	60	24726	70
23520	204	23763	185	24043	183	24150	192	24437	60	24727	290
23525	204	23764	185	24045	89	24151	192	24444	60	24728	290
23530	204	23800	184	24050	91	24152	193	24451	60	24729	290
23531	204	23840	322	24055	88	24152	315	24457	60	24730	69
23551	204	23845	323	24055	277	24153	190	24464	60	24731	69
23560	204	23846	323	24060	88	24155	194	24468	60	24732	69
23561	204	23847	323	24061	88	24156	194	24476	60	24734	73
23562	204	23875	223	24062	88	24158	194	24483	60	24735	70
23563	204	23875	357	24063	88	24159	194	24620	71	24736	70
23564	204	23904	185	24064	88	24159	293	24621	71	24737	70
23565	204	23906	185	24065	88	24160	93	24622	71	24738	70
23566	204	23908	185	24066	88	24161	93	24623	71	24739	70
23570	203	23910	185	24067	88	24162	93	24624	71	24740	70
23571	203	23912	185	24068	88	24163	93	24627	71	24741	70
23572	203	23914	185	24069	88	24164	93	24630	71	24743	70
23573	203	23920	184	24070	88	24165	93	24633	71	24745	70
23574	203	23922	184	24071	88	24166	93	24636	71	24746	70
23585	203	23923	184	24072	88	24167	93	24638	71	24747	70
23587	203	23924	184	24073	88	24168	93	24640	71	24748	70
23589	203	23925	184	24074	88	24169	93	24642	71	24749	70
23591	203	23927	184	24075	88	24170	190	24643	71	24750	61
23595	204	23928	184	24076	88	24171	192	24647	79	24751	61
23598	204	23945	184	24077	88	24173	192	24648	79	24752	290
23600	205	23950	183	24078	88	24174	194	24649	79	24753	290
23601	205	23951	183	24080	89	24175	194	24650	72	24755	66
23602	205	23952	183	24081	89	24176	194	24651	71	24756	66
23605	205	23953	183	24082	89	24177	194	24652	71	24757	69
23607	205	23954	183	24083	89	24178	194	24655	73	24758	69
23620	205	23955	183	24084	89	24180	93	24658	73	24759	69
23625	203	23960	185	24085	89	24181	194	24661	72	24760	72
23626	203	23961	185	24086	89	24185	93	24663	72	24761	72
23628	203	23962	185	24087	89	24186	93	24665	82	24762	72
23630	203	23963	185	24098	89	24187	93	24666	82	24763	72
23632	203	23964	185	24099	89	24188	93	24667	82	24764	72
23635	203	23965	185	24100	190	24189	93	24670	72	24765	72
23637	204	23966	185	24102	190	24190	194	24671	72	24766	72
23650	210	23967	185	24104	190	24190	293	24672	72	24767	72
23652	208	23970	183	24108	93	24192	93	24673	72	24768	72
23655	210	23971	183	24109	93	24195	93	24674	72	24769	72
23657	208	23972	183	24110	190	24196	93	24675	72	24770	70

Nummer Artikel	S.	Nummer Artikel	S.	Nummer Artikel	S.	Nummer Artikel	S.	Nummer Artikel	S.	Nummer Artikel	S.
24771	70	25206	305	28032	11	31082	245	31502	252	32166	248
24772	70	25212	305	28035	13	31091	244	31503	252	32167	248
24773	70	25215	305	28040	12	31101	244	31505	247	32168	248
24774	70	25220	305	28045	12	31111	244	31506	247	32169	248
24775	71	25224	305	28050	14	31121	244	31507	247	32170	247
24776	72	25230	305	28055	14	31131	244	31510	247	32171	248
24777	71	25240	305	28060	17	31132	244	31511	247	32172	248
24778	71	25248	305	28061	17	31140	244	31512	247	32173	247
24779	72	25260	305	28065	17	31141	244	31513	247	32174	248
24780	73	25296	305	28070	10	31142	244	31514	247	32176	248
24781	73	25350	305	28075	15	31143	244	31515	247	32186	248
24782	73	25369	305	28076	18	31144	244	31517	247	32196	248
24783	73	25370	305	28080	19	31145	244	31519	252	32206	248
24784	73	25371	305	28081	19	31146	244	31520	249	32216	248
24785	73	25372	305	28083	19	31148	244	31521	249	32226	248
24786	73	25373	305	28085	19	31150	245	31522	249	32234	248
24787	73	25374	305	28086	19	31151	245	31523	249	32240	248
24788	73	25376	305	28090	20	31155	245	31524	249	32265	250
24789	73	25378	305	28101	21	31218	247	31541	249	32268	251
24790	72	25379	305	28102	20	31220	246	31551	249	32269	251
24791	72	25380	305	28103	20	31221	246	31552	249	32270	250
24792	72	25400	305	28104	21	31222	246	31553	249	32273	250
24793	72	25410	305	28210	28	31231	246	31555	249	32283	250
24794	72	26028	111	28213	28	31232	246	31556	249	32285	250
24795	71	26201	113	28215	27	31233	246	31557	249	32293	250
24796	72	26203	112	28218	28	31234	246	31558	249	32295	251
24797	71	26204	113	28220	25	31235	246	31559	249	32296	251
24798	73	26205	112	28221	23	31270	246	31601	253	32297	251
24799	71	26209	114	28223	28	31271	246	31602	253	32298	251
25001	305	26211	113	28225	24	31280	246	31603	253	32301	251
25002	305	26216	114	28228	28	31281	246	31610	249	32302	251
25003	305	26217	114	28229	28	31320	247	31641	253	32311	255
25004	305	26218	114	28230	26	31322	247	31651	253	32312	254
25005	305	26219	114	28233	28	31330	246	31655	253	32313	251
25006	305	26520	115	28240	36	31332	246	32001	250	32314	254
25009	305	26521	115	28267	29	31334	246	32002	250	32315	255
25012	305	26705	228	28275	50	31340	246	32003	250	32316	255
25015	305	26706	228	28278	50	31341	246	32013	250	32317	254
25016	305	26707	228	28280	50	31343	246	32014	250	32318	255
25020	305	26720	228	28282	50	31360	246	32015	250	32319	255
25024	305	26721	228	28340	37	31362	246	32016	250	32320	254
25025	305	26722	228	28342	37	31380	246	32018	250	32321	255
25030	305	26730	272	28345	37	31382	246	32020	250	32322	255
25040	305	26731	272	28346	37	31390	246	32021	250	32323	255
25048	305	26735	272	30003	256	31392	246	32022	253	32324	255
25060	305	26736	272	30003	259	31400	246	32023	253	32325	255
25096	305	26740	273	30004	256	31402	246	32024	250	32326	255
25150	305	26775	292	30004	259	31403	246	32026	250	32327	254
25153	305	26780	273	30005	256	31404	246	32037	251	32328	255
25155	305	26781	273	30005	259	31452	253	32038	251	32329	254
25160	305	26782	273	30007	256	31453	253	32040	253	32330	255
25162	305	26783	273	30007	259	31454	253	32041	253	32331	255
25163	305	26973	216	31005	245	31455	247	32042	253	32332	254
25164	305	26974	216	31006	245	31456	247	32043	253	32333	254
25167	305	26975	216	31007	245	31461	248	32044	253	32335	255
25169	305	26976	216	31008	245	31467	248	32050	253	32337	254
25170	305	26977	216	31009	245	31468	248	32051	253	32338	254
25171	305	28000	4	31011	245	31471	248	32052	253	33168	254
25179	305	28001	5	31021	245	31481	248	32053	253	33275	296
25180	305	28002	5	31031	245	31491	248	32060	250	34005	256
25181	305	28003	6	31041	245	31493	248	32062	250	34006	256
25182	305	28004	6	31051	245	31494	248	32064	250	34007	256
25183	305	28005	7	31052	245	31495	248	32066	250	34027	255
25184	305	28006	7	31053	245	31496	248	32089	251	34028	255
25186	305	28007	8	31061	245	31497	252	32161	248	34033	260
25188	305	28008	8	31062	245	31498	248	32162	248	34041	256
25189	305	28021	9	31071	245	31499	248	32163	248	34051	256
25190	305	28025	9	31072	245	31500	248	32164	248	34053	256
25195	305	28030	11	31081	245	31501	252	32165	248	34061	256

Nummer Artikel	S.	Nummer Artikel	S.	Nummer Artikel	S.	Nummer Artikel	S.	Nummer Artikel	S.	Nummer Artikel	S.
34071	256	34405	258	35082	263	35345	40	36130	277	37115	291
34081	256	34406	259	35085	262	35345	286	36136	277	37117	278
34091	256	34407	259	35086	262	35346	41	36138	277	37119	291
34101	256	34409	259	35087	262	35346	288	36139	277	37120	291
34111	256	34410	259	35091	262	35347	41	36140	277	37121	296
34115	256	34411	259	35092	262	35347	288	36145	274	37122	296
34116	256	34412	259	35093	262	35348	40	36160	274	37123	364
34117	256	34413	259	35094	263	35348	286	36175	274	37124	364
34121	256	34414	259	35095	263	35360	46	36190	274	37125	282
34122	256	34415	258	35096	263	35361	46	36191	274	37126	282
34132	256	34416	258	35103	264	35362	46	36195	277	37127	282
34142	256	34417	259	35113	264	35500	266	36199	274	37129	364
34152	256	34418	259	35123	264	35501	266	36200	274	37130	281
34153	256	34419	258	35125	264	35502	266	36300	209	37131	281
34154	256	34420	258	35126	264	35503	266	36308	292	37132	281
34155	256	34421	259	35127	264	35504	266	36310	273	37135	231
34156	256	34422	259	35142	262	35505	266	36312	292	37139	231
34157	256	34423	259	35300	38	35506	266	36318	283	37140	231
34158	256	34424	259	35300	261	35507	266	36319	283	37141	231
34159	256	34425	259	35305	39	35508	266	36325	283	37142	231
34160	256	34426	259	35305	262	35510	266	36326	16	37143	231
34200	252	34428	259	35310	38	35511	266	36326	283	37144	231
34201	252	34429	259	35310	261	35512	266	36328	16	37145	231
34202	252	34439	258	35311	38	35514	266	36329	16	37148	282
34203	252	34440	258	35311	261	35515	266	36410	208	37149	282
34221	260	34441	258	35315	39	35516	266	37005	302	37150	282
34223	260	34442	258	35315	262	35517	266	37006	279	37151	282
34231	260	34443	258	35316	38	35518	267	37006	279	37152	282
34235	260	34445	258	35316	261	35519	267	37007	279	37153	282
34237	260	34446	258	35317	38	35524	267	37007	279	37154	282
34238	260	34447	258	35317	261	35525	267	37008	279	37155	280
34241	260	34448	259	35318	38	35527	267	37009	279	37156	280
34243	260	34449	258	35318	261	35532	267	37011	278	37157	280
34251	260	34450	258	35319	38	35533	267	37012	279	37158	282
34261	260	34451	258	35319	261	35539	267	37021	278	37162	281
34262	260	34452	259	35320	50	35540	267	37025	278	37166	273
34265	260	34453	258	35322	50	35542	267	37025	278	37170	281
34271	252	34454	258	35323	42	35552	267	37026	278	37171	281
34272	252	34455	259	35323	289	35553	267	37026	278	37172	281
34273	252	34456	259	35325	42	35555	267	37028	278	37173	282
34274	252	34457	259	35325	289	35603	269	37028	278	37174	282
34275	252	34458	259	35326	42	35604	269	37029	278	37175	281
34276	252	34480	258	35326	289	35605	269	37029	278	37176	281
34280	252	34481	258	35327	42	35833	52	37031	253	37177	282
34281	252	34482	258	35327	289	35845	52	37041	253	37178	282
34282	252	34485	258	35328	42	35850	52	37050	278	37185	281
34283	252	34486	258	35328	42	36014	276	37051	253	37186	281
34284	252	34490	259	35328	289	36024	276	37052	278	37187	281
34285	252	34491	259	35328	289	36034	276	37053	278	37188	281
34300	292	34496	259	35329	42	36035	276	37054	278	37189	281
34301	252	34500	260	35329	42	36036	276	37055	278	37190	281
34303	292	35006	263	35329	289	36046	276	37065	284	37192	281
34304	252	35007	263	35329	289	36056	277	37066	284	37195	282
34305	252	35011	264	35330	40	36057	277	37067	284	37196	282
34305	292	35012	263	35330	287	36058	277	37068	284	37197	282
34306	252	35013	263	35331	41	36059	277	37069	284	37198	282
34306	292	35015	264	35331	288	36076	275	37070	284	37199	282
34307	252	35021	264	35332	41	36077	275	37094	284	37200	280
34307	292	35023	262	35332	288	36080	275	37095	284	37201	280
34308	252	35038	262	35333	41	36081	275	37096	284	37202	280
34308	292	35048	264	35333	288	36082	275	37097	284	37203	280
34315	293	35058	262	35334	41	36085	275	37098	284	37204	280
34316	131	35059	263	35334	288	36086	275	37101	253	37205	280
34316	293	35068	264	35335	42	36087	275	37102	280	37210	280
34400	258	35069	263	35335	289	36102	275	37105	280	37211	280
34401	258	35070	263	35336	41	36103	275	37106	280	37212	280
34402	259	35078	263	35336	288	36105	275	37107	280	37216	291
34403	259	35079	263	35344	41	36126	277	37111	253	37217	291
34404	258	35081	263	35344	287	36128	277	37114	291	37218	291

Nummer Artikel	S.	Nummer Artikel	S.	Nummer Artikel	S.	Nummer Artikel	S.	Nummer Artikel	S.	Nummer Artikel	S.
37220	280	37344	236	38022	299	38949	224	39217	290	42179	353
37230	292	37345	236	38024	297	38950	290	39218	290	42180	354
37231	292	37350	235	38025	298	38951	290	39219	290	42181	354
37232	292	37500	267	38026	279	38952	290	39238	292	42182	354
37233	292	37501	267	38027	297	38953	290	39240	290	42185	354
37234	292	37505	267	38028	297	38954	290	39241	290	42186	354
37235	292	37506	267	38030	299	38955	224	39242	290	42187	354
37236	291	37509	268	38031	299	38956	224	39243	290	42188	354
37237	291	37510	268	38032	297	38957	224	39244	290	42190	224
37238	291	37511	268	38042	279	38958	224	39245	292	42190	354
37239	291	37512	268	38045	279	38959	224	40050	353	42201	355
37243	303	37515	268	38050	223	38960	224	40051	353	42202	355
37244	303	37516	268	38052	223	38961	224	40052	353	42203	355
37245	303	37517	268	38054	223	38963	226	40053	353	42207	355
37246	303	37518	268	38055	223	38964	225	40054	353	42208	355
37247	303	37527	268	38060	223	38965	225	40055	353	42209	355
37248	303	37530	268	38063	223	38966	225	40056	353	42210	355
37250	303	37532	268	38065	223	38968	224	40057	353	42211	355
37251	303	37533	268	38095	223	38969	226	40058	353	42212	355
37252	303	37539	269	38096	223	38970	290	40059	353	42213	355
37253	303	37541	269	38097	223	38971	290	40060	353	42214	355
37255	225	37545	307	38895	284	38972	226	40075	353	42217	355
37256	225	37546	307	38896	284	38973	226	40076	353	42218	355
37257	225	37549	210	38899	284	38975	226	40077	353	42219	355
37258	225	37553	212	38900	284	38975	226	40077	353	42219	355
37259	225	37560	209	38901	285	38980	224	40100	352	42220	355
37263	225	37564	269	38902	285	38981	224	40120	352	42221	355
37264	225	37570	192	38903	285	38985	226	41050	352	42228	355
37266	225	37570	209	38904	285	38990	225	41080	352	42229	355
37267	225	37611	53	38905	285	38991	225	41081	352	42230	355
37268	225	37615	53	38905	285	38995	225	41082	352	42244	355
37270	225	37616	53	38906	285	39000	296	41083	352	42248	355
37271	225	37616	53	38907	284	39001	296	41100	352	42249	355
37272	225	37647	218	38907	284	39002	296	41101	352	42251	355
37272	225	37660	306	38908	284	39002	296	41101	352	42251	355
37273	225	37660	306	38909	284	39003	296	41102	352	42252	355
37273	225	37730	53	38909	284	39005	296	41103	352	42253	355
37275	225	37731	53	38910	285	39005	296	41103	352	42253	355
37280	226	37732	53	38911	285	39010	296	41120	352	42255	355
37281	226	37732	53	38912	285	39012	296	41121	352	42256	355
37281	226	37733	53	38912	285	39012	296	41121	352	42256	355
37285	282	37733	53	38913	285	39014	296	41122	352	42257	355
37285	282	37740	53	38913	285	39014	296	41122	352	42257	355
37286	282	37740	53	38914	285	39020	296	41123	352	42260	355
37286	282	37741	53	38914	285	39021	296	41150	352	42261	355
37287	282	37741	53	38915	285	39021	296	41150	352	42261	355
37287	282	37744	53	38916	285	39045	296	41151	352	42312	291
37288	282	37745	53	38917	285	39065	296	41152	352	42312	354
37288	282	37745	53	38917	285	39065	296	41152	352	42312	354
37289	282	37746	53	38918	285	39090	296	41153	352	42365	222
37289	282	37746	53	38918	285	39090	296	41153	352	42365	222
37290	303	37747	53	38919	279	39145	296	42101	352	42366	222
37291	303	37747	53	38919	279	39145	296	42101	352	42366	222
37291	303	37750	53	38920	279	39165	296	42102	352	42367	222
37295	226	37751	53	38920	279	39165	296	42102	352	42367	222
37295	226	37751	53	38923	279	39190	296	42103	352	42368	222
37296	226	37760	53	38923	279	39190	296	42103	352	42368	222
37296	226	37760	53	38924	225	39192	296	42115	291	42420	291
37297	226	37761	53	38924	225	39192	296	42115	291	42420	291
37300	235	38000	298	38925	224	39192	323	42120	291	43050	358
37300	235	38000	298	38926	226	39193	296	42150	353	43058	358
37301	235	38001	297	38927	224	39193	323	42151	353	43060	358
37301	235	38001	297	38927	224	39193	323	42151	353	43060	358
37302	235	38002	298	38928	225	39194	223	42152	353	43068	358
37302	235	38002	298	38928	225	39194	223	42152	353	43068	358
37303	235	38003	298	38929	225	39195	223	42153	353	43071	358
37303	235	38003	298	38929	225	39195	223	42153	353	43071	358
37308	236	38004	299	38930	226	39196	223	42155	353	43072	358
37308	236	38004	299	38930	226	39196	223	42155	353	43072	358
37309	236	38005	299	38931	224	39197	223	42156	353	43077	358
37309	236	38005	299	38931	224	39197	223	42156	353	43077	358
37310	235	38006	298	38932	224	39198	223	42157	353	43082	358
37310	235	38006	298	38932	224	39198	223	42157	353	43082	358
37311	235	38007	298	38933	226	39199	223	42158	353	43083	358
37311	235	38007	298	38933	226	39199	223	42158	353	43083	358
37317	313	38008	298	38934	225	39200	223	42160	353	43084	358
37317	313	38008	298	38934	225	39200	223	42160	353	43084	358
37320	235	38009	298	38935	226	39201	223	42161	353	43086	358
37320	235	38009	298	38935	226	39201	223	42161	353	43086	358
37321	235	38010	298	38937	226	39202	223	42162	353	43087	359
37321	235	38010	298	38937	226	39202	223	42162	353	43087	359
37325	234	38012	297	38939	226	39203	223	42163	353	43089	359
37325	234	38012	297	38939	226	39203	223	42163	353	43089	359
37326	234	38013	297	38940	226	39204	223	42170	354	43090	359
37326	234	38013	297	38940	226	39204	223	42170	354	43090	359
37328	234	38014	299	38941	226	39205	223	42171	354	43094	359
37328	234	38014	299	38941	226	39205	223	42171	354	43094	359
37330	234	38014	299	38942	225	39206	290	42172	354	43097	358
37330	234	38014	299	38942	225	39206	290	42172	354	43097	358
37331	234	38015	299	38943	226	39207	290	42173	354	43098	359
37331	234	38015	299	38943	226	39207	290	42173	354	43098	359
37332	234	38016	299	38944	224	39208	290	42174	354	43099	359
37332	234	38016	299	38944	224	39208	290	42174	354	43099	359
37340	236	38017	299	38945	224	39210	290	42175	353	43300	347
37340	236	38017	299	38945	224	39210	290	42175	353	43300	347
37341	236	38018	299	38946	224	39212	290	42176	353	43301	347
37341	236	38018	299	38946	224	39212	290	42176	353	43301	347
37342	236	38020	298	38947	224	39214	290	42177	353	44041	322
37342	236	38020	298	38947	224	39214	290	42177	353	44041	322
37343	236	38021	299	38948	224	39216	290	42178	353	44042	322
37343	236	38021	299	38948	224	39216	290	42178	353	44042	322

Nummer Artikel	S.	Nummer Artikel	S.	Nummer Artikel	S.	Nummer Artikel	S.	Nummer Artikel	S.	Nummer Artikel	S.
44043	322	45034	319	45099	310	45178	333	45268	335	45391	324
44050	322	45035	318	45100	334	45179	331	45269	335	45392	324
44053	319	45036	322	45101	334	45180	327	45270	39	45393	324
44950	131	45038	319	45102	334	45181	327	45271	39	45394	324
44950	315	45039	319	45104	334	45182	333	45280	334	45395	324
44955	319	45040	319	45105	334	45183	333	45283	334	45396	325
44960	323	45041	319	45106	334	45184	331	45285	334	45397	325
44965	338	45042	319	45107	334	45185	331	45286	334	45398	325
44970	313	45043	323	45108	334	45186	331	45287	334	45399	325
44971	313	45044	322	45110	326	45187	332	45289	329	45400	325
44972	310	45045	136	45111	327	45190	332	45290	329	45401	325
44980	310	45045	320	45112	327	45191	332	45291	329	45450	357
44980	310	45046	136	45113	327	45192	332	45292	329	45451	357
44980	311	45046	320	45114	327	45193	332	45293	329	45452	357
44981	310	45047	323	45115	327	45194	332	45294	328	45453	357
44981	310	45048	136	45116	326	45195	332	45295	328	45460	357
44981	311	45048	312	45117	326	45196	332	45296	328	45461	357
44981	311	45048	320	45118	326	45197	332	45297	328	45462	357
44982	310	45049	322	45120	327	45198	332	45298	328	45463	357
44982	310	45050	338	45122	327	45199	332	45299	328	45465	357
44982	311	45051	338	45123	326	45200	332	45300	333	45466	357
44983	310	45052	338	45124	326	45203	332	45301	333	45467	357
44983	310	45053	339	45125	326	45204	332	45320	339	45470	357
44983	311	45054	339	45126	326	45206	332	45321	339	45471	226
44984	311	45055	339	45130	329	45211	332	45323	337	45471	323
44984	312	45056	318	45131	329	45213	328	45323	348	45472	323
44984	312	45057	318	45132	329	45214	327	45325	337	45473	323
44985	311	45058	318	45133	329	45215	329	45326	337	45480	357
44985	312	45059	318	45134	330	45216	328	45326	337	45485	357
44991	311	45060	193	45135	329	45217	329	45327	337	45490	314
44992	311	45060	315	45136	329	45218	328	45328	337	45496	357
44995	314	45061	193	45137	329	45219	329	45329	337	45497	357
44996	312	45061	315	45138	328	45220	334	45330	337	45498	357
44997	312	45062	193	45139	328	45221	334	45330	350	45499	357
44998	312	45062	315	45140	328	45222	334	45331	337	45500	321
44999	313	45063	310	45141	328	45223	334	45331	350	45502	321
45000	314	45065	318	45142	328	45224	334	45341	333	45503	321
45001	314	45066	318	45143	328	45225	334	45342	333	45505	321
45002	314	45067	318	45144	329	45226	334	45343	333	45506	321
45003	314	45068	136	45145	329	45227	334	45344	333	45508	321
45005	314	45068	312	45146	330	45228	334	45345	333	45509	321
45006	314	45068	320	45147	331	45229	334	45346	333	45511	321
45007	314	45069	131	45150	331	45239	336	45347	333	45512	321
45008	314	45069	315	45151	331	45240	336	45348	333	45513	321
45009	314	45070	340	45152	330	45241	336	45349	333	45515	321
45010	312	45071	338	45153	330	45242	336	45350	333	45516	321
45011	313	45073	136	45154	330	45244	335	45351	333	45517	321
45012	313	45073	320	45155	330	45245	335	45352	333	45518	321
45014	312	45074	323	45156	331	45246	335	45353	333	45519	321
45015	313	45079	319	45158	330	45247	335	45354	333	45520	321
45016	313	45080	319	45159	331	45248	335	45370	136	45521	321
45017	311	45081	131	45160	331	45249	335	45370	320	45522	321
45018	312	45081	315	45161	331	45250	335	45372	325	45523	321
45019	312	45082	131	45162	330	45251	335	45372	333	45524	321
45020	310	45082	315	45163	330	45253	335	45373	325	45525	321
45021	312	45083	131	45164	331	45254	335	45373	333	45526	321
45023	310	45083	315	45167	330	45256	335	45374	325	45527	321
45025	313	45084	131	45168	331	45257	335	45374	333	45528	321
45026	312	45084	315	45169	331	45260	335	45375	325	45529	321
45027	313	45085	319	45170	336	45261	335	45375	333	45530	321
45029	313	45086	323	45171	336	45262	335	45376	325	45531	321
45030	193	45088	311	45172	336	45262	335	45376	333	45532	321
45030	315	45089	311	45172	336	45263	335	45377	325	45533	321
45031	193	45093	323	45173	336	45263	335	45377	333	45534	321
45031	315	45094	311	45173	336	45265	335	45385	324	45535	322
45032	193	45095	310	45174	333	45266	335	45386	324	45540	321
45032	315	45096	310	45175	332	45267	335	45388	324	45541	321
45033	193	45097	311	45176	333	45267	335	45389	324	45542	321
45033	315	45098	310	45177	333	45268	335	45390	324	45543	321

Nummer Artikel	S.	Nummer Artikel	S.	Nummer Artikel	S.	Nummer Artikel	S.	Nummer Artikel	S.	Nummer Artikel	S.
45550	321	45660	322	48094	49	50544	233	51244	227	52055	307
45551	321	45661	322	48095	49	50549	232	51245	227	52060	307
45552	321	45662	322	48096	49	50550	230	51246	227	52065	307
45553	321	45663	322	48097	49	50551	230	51247	227	52070	300
45555	322	45664	322	48410	306	50553	230	51258	227	52071	300
45556	321	45670	322	48411	306	50554	230	51259	227	52075	300
45557	321	45671	322	48415	306	50555	233	51260	227	52076	300
45558	321	45672	322	48420	306	50556	230	51261	227	52077	300
45559	321	45673	322	48452	307	50557	232	51262	227	52078	300
45560	322	48001	48	48453	307	50558	232	51264	227	52101	349
45562	321	48002	48	48454	307	50559	230	51271	227	52102	349
45563	321	48004	47	48455	307	50560	230	51272	227	52103	349
45564	321	48005	47	48456	307	50562	230	51273	227	52104	349
45565	321	48006	47	48457	307	50563	230	51274	227	52105	349
45570	354	48007	47	48719	273	50564	230	51275	227	52108	348
45571	354	48008	49	48729	269	50570	230	51276	227	52109	349
45572	354	48009	49	48730	269	50571	230	51278	227	52113	349
45573	354	48010	48	48731	269	50585	233	51280	227	52114	349
45580	354	48011	48	50030	355	50585	303	51281	227	52115	349
45600	334	48013	15	50031	355	50586	233	51282	227	52116	349
45601	334	48013	48	50032	355	50586	303	51283	227	52119	348
45602	334	48015	47	50033	355	50587	233	51284	227	52126	350
45603	334	48020	46	50035	228	50587	303	51286	227	52130	280
45604	334	48021	46	50035	355	50588	233	51287	227	52135	348
45605	334	48022	46	50036	228	50588	303	51288	227	52160	349
45606	334	48030	47	50036	355	51100	228	51300	227	52161	349
45607	334	48031	48	50037	355	51102	228	51301	227	52162	349
45608	334	48032	48	50038	355	51103	228	51302	227	52163	349
45609	334	48033	48	50040	355	51104	228	51303	227	52164	349
45610	334	48034	48	50041	355	51105	228	51304	227	52168	348
45611	334	48036	47	50042	355	51106	228	51305	227	52173	348
45612	334	48037	47	50050	222	51107	228	51306	227	52175	348
45613	334	48040	48	50050	222	51108	228	51307	227	52176	348
45614	334	48041	48	50051	222	51109	228	51308	227	52185	349
45615	334	48042	48	50052	222	51110	228	51320	227	52186	349
45616	334	48043	48	50052	222	51111	228	51321	227	52187	349
45617	334	48046	46	50100	227	51120	228	51322	227	52188	349
45618	334	48046	49	50101	227	51121	228	51323	227	52189	349
45619	334	48047	46	50102	227	51122	228	51324	227	52190	349
45620	334	48047	49	50103	227	51123	228	51325	227	52191	349
45621	334	48050	49	50104	227	51124	228	51327	227	52192	349
45622	334	48051	49	50106	227	51125	228	51341	227	52193	349
45623	334	48054	49	50108	227	51126	228	51402	228	52194	349
45624	334	48055	49	50500	233	51127	228	51403	228	52195	349
45625	334	48056	49	50503	233	51130	228	51404	228	52196	349
45626	334	48057	49	50510	230	51131	228	51405	228	52197	348
45627	334	48060	49	50511	230	51132	228	51406	228	52198	348
45628	334	48061	49	50512	230	51196	228	51407	228	52202	300
45629	334	48062	49	50513	230	51197	228	51408	228	52203	300
45630	334	48063	49	50514	230	51198	228	51410	228	52204	300
45631	334	48064	49	50518	232	51199	228	51412	228	52205	300
45632	334	48065	49	50519	232	51204	227	51413	228	52206	300
45633	334	48066	49	50520	232	51205	227	51414	228	52207	300
45634	334	48067	49	50522	232	51206	227	51415	228	52208	300
45635	334	48068	49	50524	232	51207	227	51416	228	52212	300
45636	334	48070	49	50525	232	51208	227	51417	228	52213	300
45637	334	48071	49	50526	232	51209	227	51418	228	52214	300
45638	334	48072	49	50527	233	51210	227	51418	228	52215	300
45639	334	48075	49	50529	232	51211	227	51420	228	52215	300
45650	322	48076	49	50531	233	51212	227	51430	228	52216	300
45651	322	48077	49	50532	233	51220	227	51431	228	52217	300
45652	322	48080	49	50533	232	51221	227	51432	228	52218	300
45653	322	48081	49	50535	232	51221	227	51433	228	52220	300
45654	322	48085	49	50536	232	51222	227	51435	228	52223	300
45655	322	48086	49	50537	232	51225	227	51436	228	52284	300
45656	322	48087	49	50539	232	51226	227	51450	228	52285	300
45657	322	48090	49	50540	233	51227	227	52011	249	52286	300
45658	322	48091	49	50541	233	51241	227	52011	303	52288	300
45659	322	48093	49	50542	233	51242	227	52030	252	52305	301
						51243	227	52050	307	52306	301

Nummer Artikel	S.	Nummer Artikel	S.	Nummer Artikel	S.	Nummer Artikel	S.	Nummer Artikel	S.	Nummer Artikel	S.
52328	301	55356	229	61003	344	61098	345	61236	217	70025	44
52331	301	55357	229	61004	344	61098	351	61240	197	70026	44
52334	301	55358	229	61005	341	61111	346	61250	351	70030	44
52391	301	55359	229	61005	351	61112	346	61251	319	70031	44
52421	301	55360	229	61006	341	61114	346	61251	351	70032	44
52424	301	55361	229	61006	351	61120	346	61252	351	70033	44
52428	301	55362	229	61007	341	61121	346	61253	351	70035	44
52456	301	55400	356	61008	341	61130	338	61254	351	70036	44
52471	301	55401	356	61009	345	61131	338	61255	351	70037	44
52600	302	55402	356	61010	341	61132	339	61256	351	70040	43
52601	302	55403	356	61012	345	61133	339	61290	346	70060	44
52602	302	55404	356	61013	344	61134	339	61291	346	70061	44
52605	302	55405	356	61014	345	61135	339	61292	346	70062	44
52610	302	55406	356	61015	341	61141	339	61293	346	70063	44
52611	248	55420	356	61018	345	61142	340	61294	318	70064	43
52612	248	55421	356	61019	344	61143	340	61295	318	70065	44
52620	302	55422	356	61020	342	61144	340	61296	318	70066	43
52625	302	55423	356	61021	342	61145	340	61297	318	70070	44
52630	302	55424	356	61022	343	61146	340	61299	356	70075	44
52635	302	55425	356	61024	343	61150	338	61300	356	70090	45
52640	302	55429	356	61025	342	61155	341	61301	356	70091	45
52645	302	55430	356	61026	342	61156	341	61302	356	70092	45
52652	302	55431	356	61027	343	61157	341	61320	197	70093	45
52656	302	55432	356	61028	345	61158	341	61321	197	70094	45
52662	302	55433	356	61029	341	61161	344	61322	197	70095	45
52666	302	55436	356	61030	340	61162	344	61323	197	70096	45
52671	302	55437	356	61031	340	61163	344	61324	197	70098	210
52694	302	55450	356	61032	340	61164	345	61325	197	81011	361
52695	302	55452	356	61033	340	61165	345	61326	197	81012	361
54008	303	55453	356	61034	340	61166	345	61327	197	81013	361
55040	229	55454	356	61035	346	61169	251	61328	197	81014	361
55050	229	55455	356	61036	346	61171	350	61329	197	81015	361
55051	229	55456	356	61038	346	61172	348	61330	197	81016	361
55060	229	55457	356	61040	346	61172	350	61331	197	81022	361
55080	229	55460	356	61042	346	61173	350	61340	317	81023	361
55100	229	55461	356	61044	345	61174	350	61341	317	81024	361
55120	229	55462	356	61045	340	61175	350	61342	317	81025	361
55140	229	55465	356	61046	340	61176	350	61343	317	81035	361
55160	229	55640	229	61047	340	61177	350	61344	317	81036	361
55180	229	55642	229	61048	340	61183	351	61345	317	81053	364
55181	229	55645	229	61050	342	61184	351	61346	317	81054	364
55200	229	55650	229	61050	351	61189	351	65062	307	81057	364
55201	229	60001	347	61051	342	61190	351	65063	307	81070	364
55220	229	60006	347	61051	351	61192	350	65064	307	81071	364
55221	229	60008	347	61052	343	61193	350	65065	307	81077	364
55240	229	60012	347	61052	351	61194	350	69900	294	81100	364
55300	229	60018	347	61053	343	61195	351	69901	294	81101	364
55315	229	60019	347	61054	343	61200	350	69902	294	81102	364
55316	229	60020	347	61056	342	61201	347	69903	294	81103	364
55317	229	60022	347	61057	342	61201	350	69904	295	81104	364
55318	229	60100	251	61058	343	61202	350	69905	294	81105	364
55319	229	60115	273	61059	343	61203	345	69906	294	81106	364
55331	229	60116	273	61060	340	61204	351	69907	295	81150	362
55332	229	60117	273	61061	340	61205	351	69908	295	81151	362
55333	229	60118	273	61062	340	61207	351	69909	295	81152	362
55334	229	60121	273	61063	340	61208	350	69910	295	81155	362
55335	229	60123	273	61067	346	61209	345	69911	295	81160	362
55336	229	60125	272	61068	346	61215	351	69912	295	81165	362
55337	229	60130	272	61069	346	61218	251	69914	294	81170	362
55339	229	60132	272	61070	346	61219	351	69917	295	81175	362
55340	229	60155	272	61077	351	61221	318	69918	294	81178	362
55341	229	60157	272	61079	351	61221	318	69919	294	81180	362
55342	229	60201	347	61079	351	61221	318	69920	295	81185	362
55350	229	60206	347	61085	319	61221	318	69923	295	81186	362
55351	229	60208	347	61088	342	61222	345	69928	295	81188	362
55352	229	60212	347	61089	342	61223	344	69930	296	81189	362
55353	229	61000	342	61090	343	61224	346	69931	296	81190	362
55354	229	61001	342	61097	344	61224	346	70020	44	81191	362
55355	229	61002	343	61097	351	61230	351	70021	44	81195	361

Nummer		Nummer		Nummer		Nummer		Nummer		Nummer	
Artikel	S.	Artikel	S.	Artikel	S.	Artikel	S.	Artikel	S.	Artikel	S.
81196	361	81267	363	81337	363	81408	363	82103	307		
81197	361	81268	363	81338	363	81409	363	82104	307		
81200	363	81269	363	81339	363	81410	363	89775	51		
81201	363	81270	363	81340	363	81411	363	89970	51		
81202	363	81271	363	81341	363	81412	363	89973	51		
81203	363	81272	363	81342	363	81413	363	89975	51		
81204	363	81273	363	81343	363	81414	363	89980	51		
81205	363	81274	363	81344	363	81415	363	89985	51		
81206	363	81275	363	81345	363	81416	363	89987	51		
81207	363	81276	363	81346	363	81417	363	89988	51		
81208	363	81277	363	81347	363	81418	363	89989	51		
81209	363	81278	363	81348	363	81419	363	89990	51		
81210	363	81279	363	81349	363	81420	363	90070	278		
81211	363	81280	363	81350	363	81421	363	90071	278		
81212	363	81281	363	81351	363	81422	363	90072	278		
81213	363	81282	363	81352	363	81423	363	90191	56		
81214	363	81284	363	81353	363	81424	363	90192	57		
81215	363	81285	363	81354	363	81425	363	18610A	150		
81216	363	81286	363	81355	363	81426	363	18611A	150		
81217	363	81287	363	81356	363	81427	363	18612A	150		
81218	363	81288	363	81357	363	81428	363	18613A	150		
81219	363	81289	363	81358	363	81429	363	18614A	150		
81220	363	81290	363	81359	363	81430	363	18615A	150		
81221	363	81291	363	81360	363	81431	363	18632A	147		
81222	363	81292	363	81361	363	81432	363	18633A	147		
81223	363	81293	363	81362	363	81433	363	18636A	147		
81224	363	81294	363	81363	363	81434	363	18637A	147		
81225	363	81295	363	81364	363	81435	363	18638A	147		
81226	363	81296	363	81365	363	81436	363	18827A	147		
81227	363	81297	363	81366	363	81437	363	18828A	147		
81228	363	81298	363	81367	363	81438	363	18830A	147		
81229	363	81299	363	81370	363	81439	363	18831A	147		
81230	363	81300	363	81371	363	81440	363	81011A	361		
81231	363	81301	363	81372	363	81441	363	81011F	361		
81232	363	81302	363	81373	363	81442	363	81011G	361		
81233	363	81303	363	81374	363	81443	363	81011H	361		
81234	363	81304	363	81375	363	81444	363	81011R	361		
81235	363	81305	363	81376	363	81445	363	M90203	365		
81236	363	81306	363	81377	363	81447	363	M90204	365		
81237	363	81307	363	81378	363	81448	363	M90205	365		
81238	363	81308	363	81379	363	81449	363	M90206	365		
81239	363	81309	363	81380	363	81450	363	M90207	365		
81240	363	81310	363	81381	363	81451	363	M90210	365		
81241	363	81311	363	81382	363	81452	363	M90220	365		
81242	363	81312	363	81383	363	81453	363	M90221	365		
81243	363	81313	363	81384	363	81454	363	M90222	365		
81244	363	81314	363	81385	363	81455	363	M90400	365		
81245	363	81315	363	81386	363	81456	363	M90403	365		
81246	363	81316	363	81387	363	81457	363	M90519	365		
81247	363	81317	363	81388	363	81458	363				
81248	363	81318	363	81389	363	81459	363				
81249	363	81319	363	81390	363	81460	363				
81250	363	81320	363	81391	363	81461	363				
81251	363	81321	363	81392	363	81462	363				
81252	363	81322	363	81393	363	81463	363				
81253	363	81323	363	81394	363	81466	363				
81254	363	81324	363	81395	363	81467	363				
81255	363	81325	363	81396	363	81468	363				
81256	363	81326	363	81397	363	81469	363				
81257	363	81327	363	81398	363	81470	363				
81258	363	81328	363	81399	363	81471	363				
81259	363	81329	363	81400	363	81472	363				
81260	363	81330	363	81401	363	81473	363				
81261	363	81331	363	81402	363	81486	363				
81262	363	81332	363	81403	363	81600	364				
81263	363	81333	363	81404	363	81603	364				
81264	363	81334	363	81405	363	82100	307				
81265	363	81335	363	81406	363	82101	307				
81266	363	81336	363	81407	363	82102	307				

IM KATALOG VERWENDETE GRAFISCHE SYMBOLE



PRODUKTSPEZIFIKATIONEN VERWENDETE SYMBOLE

- S2** · funktionsteile aus hochlegierten Werkzeugstählen S2
- HSS** · funktionsteile aus Schnellarbeitsstahl
- Cr-Mo** · funktionsteile aus Chrom-Molybdän-Stahl
- CrV** · funktionsteile aus Chrom-Molybdän-Stahl
- INOX** · funktionsteile aus Edelstahl
- NYLON** · nylongriff
- TEFLON** · teflon-Oberfläche
- Zn** · verzinkte Oberfläche
- TiN** · titannitridbeschichtete Oberfläche
- HRC 58-61** · die Härte des Funktionsteilematerials (Rockwell)
- 40% PES** · materialzusammensetzung - enthält 40% Polyester
- PES** · materialzusammensetzung - aus Polyester
- Diamond** · diamantkörner auf der Oberfläche von Funktionsteilen
- Magnet** · magnetisch

- SDS+** **SDS MAX** **M14** · befestigungsart
- 72T** **36T** · anzahl der Sperrzähne
- 1/2"** **3/4"** **1/4"** · Montagegröße
- 27 dB** · Informationen zum Gehörschutz
- DIN 3113** **IP 54** · entspricht dieser Norm
- 32x** · Set enthält diese Anzahl an Produkten
- II. class** **III. class** · entspricht der angegebenen Genauigkeitsklasse
- Winter** · geeignet für kaltes Wetter
- ERGO HANDLE** · ergonomischer Griff
- HOBBY** · für den Hobbygebrauch
- 2x AAA** · Anzahl und Art der Batterien
- UV STABLE** · UV stabil
- RUBBER ENDS** · craschichere Gummienden

ANWENDUNGSSPEZIFIKATIONEN

- holz ·
- keramik ·
- plastik ·
- aluminium · **ALU**
- kupfer · **Cu**
- steine ·
- glas ·
- mauerwerk ·
- papier ·
- stahl ·
- composite ·
- fliesen ·
- rostfreier stahl · **INOX**
- gips ·
- holz mit schraube, nägel ·
- trockenbau · **DRYWALL**
- zum Bohren in Materialie mit Zugfestigkeit bis zu .. **900 MPa**

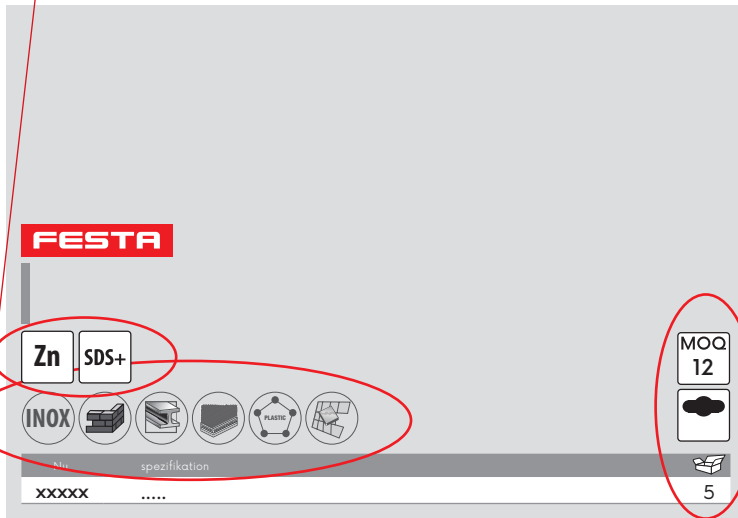

VERPACKUNGSSINFORMATIONEN

- verpackt in einer Kiste
- verpackt mit euro lot
- MOQ 12** · Mindestbestellmenge
- 5** · nein. Stückzahl im Paket

SPEZIFIKATIONEN FÜR BEWÄSSERUNGSPRODUKTE

einstellbare Sprühbilder ·

- minimum and maximum pressure · **2bar min** **4bar max**
- maximaler Wasserdurchfluss · **Max 27L/min**
- bewässertes Gebiet · **318 m²**
- Größe des Adaptergewindes · **1/2"**
- hose diameter for connector · **1/2"**



20

25

26

FESTA

PROFESSIONELLE  HANDWERKZEUGE



festatools



#festatools



festatools

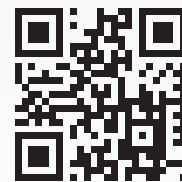

www.festa.tools

HORIZONT.

FESTA
POWER X TOOLS

FESTA
AQUATIC

ROSA KOMELON.

KDS

Stahlberg

SUPER PRO

Lescha

