



# FESTA

SCULE X PROFESIONALE



20  
25  
—  
26

**FESTA**  
POWER X TOOLS

Scule electrice și scule fără fir (cu acumulatori) în care s-au folosit componente de calitate, cele mai noi tehnologii și tendințe actuale în această gamă.

**FESTA**

O marcă de scule de mână profesionale pentru construcții, ateliere și grădină

**FESTA**  
INDUSTRY

O linie premium de scule selectate și unelte de mână de cea mai înaltă calitate, concepute pentru condiții de lucru solicitante, unde accentul este pus pe performanță.

**FESTA**  
AQUATIC

Sortiment profesional de instrumente pentru irigații cu design modern, compatibile cu produsele Rosa

**HORIZONT**  
MASTER

Brandul nivelelor de cea mai înaltă calitate

**HORIZONT**

Brandul nivelelor și al dreptarelor de înaltă calitate

**ROSA**

Sisteme calitative de irigații și scule pentru grădină

**KDS**<sup>®</sup>

Cuțite japoneze cu tradiție îndelungată

**KOMELON**<sup>®</sup>

Rulete profesionale



Instrumente profesionale pentru tăiat plăci ceramice



Producător de foarfeci calitativi pentru grădină

**Lescha**

Betoniere profesionale

**Stahlberg**

Accesorii profesionale pentru înșurubat



Brand profesional de lame fierăstrău

UNELE ELECTRICE

2 - 53

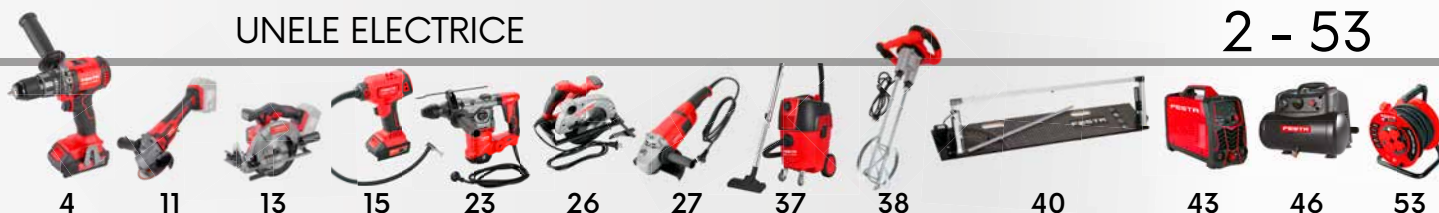

UNELTE DE TAIAT SI SLEFUIT

54 - 93



UNELTE

94 - 205



ATELIER

206 - 241



SCULE PENTRU CONSTRUCTII

242 - 307



UNELTE PENTRU GRADINARIT

308 - 359



FESTA

360 - 365



LISTA PROD USELOR

366 - 380



DRILL

4



BURGHIU CU CIOCAN

9



NAILER | CAPSATOR

10



POLIZOR UNGHIULAR

11



SLEFUITOR ORBITAL

12



FERASTRAU CIRCULAR

13



COMPRESOR DE AER

15



MAȘINĂ CU VENTUZĂ

16



PISTOL DE ȘTEMUIRE

17



LUMINA LED

17



RADIO DAB+ / FM / BT

18



BURGHIU CU CIOCAN

23



FERASTRAU CIRCULAR

26



POLIZOR UNGHIULAR

27



SLEFUITOR DE GIPS-CARTON

36



ASPIRATOARE

37



AMESTECATOR  
MATERIALE CONSTRUCTII

38



ĂPARATE DE CURĂȚAT CU  
ÎNALTĂ PRESIUNE

39



FREZE DE POLISTIREN

40



INVERTOR DE SUDARE

43



SUDORI PRIN POLIFUZIUNE

45



COMPRESOARE  
SI ACCESORII

46



PISTOALE CU AER CALD

50



ÎNCĂLZITOARE

52



CABLURI PRELUNGITOARE

53



SCULE  
ELECTRICE

2 - 53



**FESTA**  
POWER X TOOLS

**BRUSHLESS** **SHARE** **20V** *Li-ion technology*

viteză  
0-550 min<sup>-1</sup>  
0-2000 min<sup>-1</sup>

masa  
cu baterie 2,0 Ah **1,8 kg**  
cu baterie 4,0 Ah **2,1 kg**

cuplu  
**80 Nm**

chuck  
**2 - 13 mm**



Setul contine:  
- burghiu cu ciocan  
- 2.0 Ah baterie  
- 4.0 Ah baterie  
- 2.4 A încărcător  
- mâner suplimentar  
- valiză



**FESTA**  
POWER X TOOLS

**BURGHIU CU CIOCAN CU ACUMULATOR**

|              |  |                                |  |  |             |  |  |            |        |  |
|--------------|--|--------------------------------|--|--|-------------|--|--|------------|--------|--|
| max<br>80 Nm |  | I.0-8800 bpm<br>II.0-32000 bpm | I.0-550min <sup>-1</sup><br>II.0-2000min <sup>-1</sup> |  | <br>2-13 mm |  |  | <br>1,4 kg | <br>2x |  |
|--------------|--|--------------------------------|--|--|-------------|--|--|------------|--------|--|

Nu. specificatie  
**28000**

**BRUSHLESS SHARE 20V** *Li-ion technology*

viteză  
0-550 min<sup>-1</sup>  
0-2000 min<sup>-1</sup>

masa  
cu baterie 2,0 Ah **1,8 kg**  
cu baterie 4,0 Ah **2,1 kg**

cuplu  
**80 Nm**

chuck  
**2 - 13 mm**

Setul contine:  
-burghiu cu ciocan  
- 2.0 Ah baterie  
- 2.4 A încărcător  
- mâner suplimentar  
- valiză



selectarea modului  
alegerea forței cuplu

mâner suplimentar

eliberare rapidă  
cap de mandrină

mâner ergonomic cauciucat  
pentru o prindere confortabilă  
și sigură

Iluminare LED

blocarea bateriei



viteză intrerupator

comutator de  
sens de rotație

cârlig  
pentru agățat



**BURGHIU CU CIOCAN CU ACUMULATOR**



Nu. specificatie  
**28001**

2

**BRUSHLESS SHARE 20V**

viteză  
0-550 min<sup>-1</sup>  
0-2000 min<sup>-1</sup>

masa  
fara baterie  
**1,4 kg**

cuplu  
**80 Nm**

chuck  
**2 - 13 mm**

**accesorii recomandate**

2 Ah - 28080  
acumulator\* 4 Ah - 28081  
8 Ah - 28083  
2,4 A - 28085  
încărcător\* 4,0 A - 28086



selectarea modului  
alegerea forței cuplu

mâner suplimentar

eliberare rapidă  
cap de mandrină

mâner ergonomic  
cauciucat pentru o prindere  
confortabilă și sigură

Iluminare LED



viteză intrerupator

direcție  
comutator de rotație

cârlig pentru agățat



**BURGHIU CU CIOCAN CU ACUMULATOR**



\*bateria nu este inclusa

Nu. specificatie  
**28002**

5

**SHARE  
20V**

**Li-ion  
technology**

viteză  
**0-500 min<sup>-1</sup>  
0-1800 min<sup>-1</sup>**

masa  
cu baterie 2,0 Ah  
**1,7 kg**

cuplu  
**45 Nm**

chuck  
**2 - 13 mm**

Setul contine:

- burghiu cu ciocan
- 2x 2.0 Ah Baterie
- 2.4 A încărcător
- valiză
- suport și biți:

- ⊖ S5, S6 x 25 mm
- ⊕ PH1, PH2 x 25 mm
- ✦ PZ1, PZ2 x 25 mm
- burghie HSS  
2-2.5-3-4-5-6 mm



**FESTA  
POWER X TOOLS**

**BURGHIU CU CIOCAN CU ACUMULATOR**

|              |  |                |   |  |            |  |  |           |    |        |
|--------------|--|----------------|---|--|------------|--|--|-----------|----|--------|
| max<br>45 Nm |  | 0-19200<br>bpm | 0-500min <sup>-1</sup><br>0-1800min <sup>-1</sup> |  | 2-13<br>mm |  |  | 1,7 / 1,3 | 2x | Li-ion |
|--------------|--|----------------|---|--|------------|--|--|-----------|----|--------|



Nu. specificatie

28003

3

**SHARE  
20V**

viteză  
**0-550 min<sup>-1</sup>  
0-2000 min<sup>-1</sup>**

viteză intrerupator

masa  
fara baterie  
**1,4 kg**

cuplu  
**45 Nm**

chuck  
**2 - 13 mm**

accesorii recomandate

**SHARE  
20V  
Li-ion  
technology**

- 2 Ah - 28080
- acumulator\* 4 Ah - 28081
- 8 Ah - 28083
- 2,4 A - 28085
- incărcător\* 4,0 A - 28086



selectarea modului  
alegerea forței cuplu

eliberare rapidă  
cap de mandrină

maner ergonomic cauciucat  
pentru o prindere confortabilă  
și sigură

Iluminare LED

viteză intrerupator

directia rotatiei

cârlig pentru agățat



**FESTA  
POWER X TOOLS**

**BURGHIU CU CIOCAN CU ACUMULATOR**

|              |  |                |   |  |            |  |  |     |
|--------------|--|----------------|---|--|------------|--|--|-----|
| max<br>45 Nm |  | 0-19200<br>bpm | 0-500min <sup>-1</sup><br>0-1800min <sup>-1</sup> |  | 2-13<br>mm |  |  | 1,4 |
|--------------|--|----------------|---|--|------------|--|--|-----|

\*bateria nu este inclusa

Nu. specificatie

28004

5



**SHARE**  
**20V** *Li-ion*  
*technology*

viteză  
0-350 min<sup>-1</sup>  
0-1300 min<sup>-1</sup>

masa  
cu baterie 2,0 Ah  
1,3 kg

cuplu  
28 Nm

chuck  
1 - 10 mm

Setul contine:

- burghiu cu ciocan
- 2x 2.0 Ah Baterie
- 2.4 A încărcător
- valiză
- suport și biți:
- ⊖ S5, S6 x 25 mm
- ⊕ PH1, PH2 x 25 mm
- ⊕ PZ1, PZ2 x 25 mm
- burghie HSS
- 1,5-2,5-3-4-5-6 mm



selectarea modului  
alegerea forței cuplu

eliberare rapidă  
cap de mandrină

maner ergonomic  
cauciucat pentru o prindere  
confortabilă și sigură

Iluminare LED

blocarea bateriei

viteză intrerupator

comutator  
de sens de  
rotație

cârlig pentru  
agățat



**GĂURIȚI ȘURUBELNIȚĂ FĂRĂ FIR**

|              |  |   |  |            |  |     |           |    |        |
|--------------|--|---|--|------------|--|-----|-----------|----|--------|
| max<br>28 Nm |  | 0-350min <sup>-1</sup><br>0-1300min <sup>-1</sup> |  | 1-10<br>mm |  | LED | 1,3 / 0,9 | 2x | Li-ion |
|--------------|--|---|--|------------|--|-----|-----------|----|--------|



Nu. specificație  
28005

3

**SHARE**  
**20V**

viteză  
0-350 min<sup>-1</sup>  
0-1300 min<sup>-1</sup>

masa  
fara baterie  
0,9 kg

cuplu  
28 Nm

chuck  
1 - 10 mm

accesorii recomandate

- 2 Ah - 28080
- acumulator\* 4 Ah - 28081
- 8 Ah - 28083
- 2,4 A - 28085
- încărcător\* 4,0 A - 28086



selectarea modului  
alegerea forței cuplu

eliberare rapidă  
cap de mandrină

maner ergonomic cauciucat  
pentru o prindere confortabilă  
și sigură

Iluminare LED

viteză intrerupator

comutator de  
sens de rotație

cârlig pentru  
agățat



**SHARE**  
**20V** *Li-ion*  
*technology*



**GĂURIȚI ȘURUBELNIȚĂ FĂRĂ FIR**

|              |  |   |  |            |  |     |     |
|--------------|--|---|--|------------|--|-----|-----|
| max<br>28 Nm |  | 0-350min <sup>-1</sup><br>0-1300min <sup>-1</sup> |  | 1-10<br>mm |  | LED | 0,9 |
|--------------|--|---|--|------------|--|-----|-----|

\*bateria nu este inclusa

Nu. specificație  
28006



5

**Li-ion**  
technology

viteză  
**0-350 min<sup>-1</sup>**  
**0-1300 min<sup>-1</sup>**

masa  
cu baterie 1,5 Ah  
**1 kg**

cuplu  
**20 Nm**

chuck  
**1 - 10 mm**

Setul conține:

- burghiu cu ciocan
- 2x Baterie 12 V I 1.5 Ah
- încărcător 12 V I 2.4 A
- valiză
- suport și biți:
- ⊖ S5, S6 x 25 mm
- ⊕ PH1, PH2 x 25 mm
- ⊕ PZ1, PZ2 x 25 mm
- burghie HSS
- 1,5-2,5-3-4-5-6 mm



selectarea modului  
alegerea forței cuplu

eliberare rapidă  
cap de mandrină

viteză intrerupator

Iluminare LED

indicator de  
încărcare a bateriei

maner ergonomic cauciucat  
pentru o prindere confortabilă  
și sigură

directia rotatiei

baterie



**FESTA**  
POWER X TOOLS

## GĂURIȚI ȘURUBELNIȚĂ FĂRĂ FIR



Nu.      specificatie  
**28007**

**5**

**Li-ion**  
technology

viteză  
fără povară  
**200 min<sup>-1</sup>**

masa  
cu baterie 1,5 Ah  
**0,4 kg**

maximum cuplu  
**3 Nm**

purtător  
de scule  
**1/4" hexagon**

Setul conține:

- odvijač
- încărcător 5 V I 0,5 A
- biți:
- ⊖ S5 x 50 mm
- ⊕ PH1 x 50 mm
- ⊕ PH2 x 50 mm
- ⊕ H5 x 50 mm
- ⊕ T20 x 50 mm

1/4 „cap cu eliberare  
rapidă cu siguranța

setari cuplu

indicator  
de încărcare a bateriei

setare blocare  
pozitia manerului

Iluminare LED

comutator de sens de  
rotație

maner ergonomic  
cauciucat pentru o prindere  
confortabilă și sigură



Iluminare LED



**FESTA**  
POWER X TOOLS

## ȘURUBELNIȚĂ FĂRĂ FIR



Nu.      specificatie  
**28008**

**10**

**SHARE  
20V**

viteză  
fără povară  
**0-2000 min<sup>-1</sup>**

masa  
fara baterie  
**1,2 kg**

cuplu  
**150 Nm**

număr  
mişcări  
**0-3000 bpm**

1/4 „cap cu eliberare  
rapidă cu siguranța



selectabil  
directia rotatiei

maner ergonomic  
cauciucat pentru o prindere  
confortabilă și sigură

iluminare LED

cârlig pentru agățat

**accesorii recomandate**

**SHARE  
20V  
Li-ion  
technology**

2 Ah - 28080  
acumulator\* 4 Ah - 28081  
8 Ah - 28083  
2,4 A - 28085  
încărcător\* 4,0 A - 28086



**CHEIE DE IMPACT FĂRĂ FIR**



\*bateria nu este inclusa

Nu. specificatie  
**28021**



5

**SHARE  
20V**

viteză  
fără povară  
**I.0-300 min<sup>-1</sup>  
II.0-1000 min<sup>-1</sup>**

masa  
fara baterie  
**1,7 kg**

numărul de  
accesări  
**0-5000 bpm**

mâner  
**SDS+**

opritor de adâncime

comutarea modului de lucru  
(cu/fara percutie)

prindere SDS  
capul sculei

viteză intreruptor

direcție  
de rotatie  
intreruptor



**SHARE  
20V  
Li-ion  
technology**

**accesorii recomandate**

2 Ah - 28080  
acumulator\* 4 Ah - 28081  
8 Ah - 28083  
2,4 A - 28085  
încărcător\* 4,0 A - 28086



**CORDLESS BURGHIU CU CIOCAN**



\*bateria nu este inclusa

Nu. specificatie  
**28025**



MAX Ø

beton - ø 20 mm  
otel - ø 10 mm  
lemn - ø 20 mm



2

**SHARE  
20V**

frecvență filmare  
**60-100 min<sup>-1</sup>**

lungime maxima unghii / capse  
**30 mm**  
**materiale dure**

lungime maxima unghii / capse  
**50 mm**  
**materiale moi**

masa fara baterie  
**2,7 kg**



**SHARE  
20V  
Li-ion  
technology**

**accesorii recomandate**

- 2 Ah - 28080
- acumulator\* 4 Ah - 28081
- 8 Ah - 28083
- 2,4 A - 28085
- încărcător\* 4,0 A - 28086

**Unghiile**

- 23930** Cu cuie 30 mm, 2000 pcs
- 23931** Cu cuie 40 mm, 2000 pcs
- 23932** Cu cuie 50 mm, 2000 pcs

**Cataramă**

- 23935** Clip pentru unghii 30 mm, 2000 pcs
- 23936** Clip pentru unghii 40 mm, 2000 pcs

Tipuri potrivite de unghii și capse:

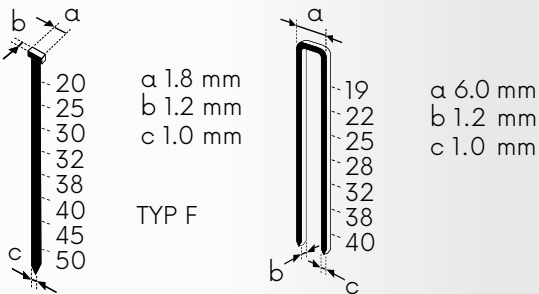

**NAILER ȘI CAPSATOR FĂRĂ FIR**

max 60 min<sup>-1</sup>

23930-32  
a 1.8 mm  
b 1.2 mm  
c 1.0 mm  
TYPE F

23935-36  
a 6.0 mm  
b 1.2 mm  
c 1.0 mm

L R

LED

2,7 kg

\*bateria nu este inclusa

| Nu.   | specificație |
|-------|--------------|
| 28070 |              |



**BRUSHLESS SHARE 20V**

Viteză fără povară  
**8500 min<sup>-1</sup>**

masa fara baterie  
**1,6 kg**

grosime maxima material tăiat  
**15 mm**

maximal diametrul roții  
**125 mm**

**SHARE 20V**  
*Li-ion technology*

**accesorii recomandate**

- 2 Ah - 28080
- acumulator\* 4 Ah - 28081
- 8 Ah - 28083
- încărcător\* 2,4 A - 28085
- 4,0 A - 28086



**POLIZOR UNGHIULAR FARA FIR**

|                        |                   |     |     |           |
|------------------------|-------------------|-----|-----|-----------|
| 8500 min <sup>-1</sup> | max<br>Ø<br>125mm | M14 | L R | KG<br>1,6 |
|------------------------|-------------------|-----|-----|-----------|

\*bateria și discul nu sunt incluse

Nu. specificatie

28030



4

orificiile de ventilație ale motorului

maner ergonomic cauciucat pentru o prindere confortabilă și sigură

blocare rotație

eliberare rapidă mecanism strat protector

siguranța comutator de operare

piulițe de strângere a roților



**SHARE 20V**

Viteză fără povară  
**8000 min<sup>-1</sup>**

masa fara baterie  
**1,6 kg**

grosime maxima material tăiat  
**15 mm**

maximal diametrul roții  
**115 mm**

**SHARE 20V**  
*Li-ion technology*

**accesorii recomandate**

- 2 Ah - 28080
- acumulator\* 4 Ah - 28081
- 8 Ah - 28083
- încărcător\* 2,4 A - 28085
- 4,0 A - 28086



**POLIZOR UNGHIULAR FARA FIR**

|                        |                   |     |     |           |
|------------------------|-------------------|-----|-----|-----------|
| 8000 min <sup>-1</sup> | max<br>Ø<br>115mm | M14 | L R | KG<br>1,6 |
|------------------------|-------------------|-----|-----|-----------|

\*bateria și discul nu sunt incluse

Nu. specificatie

28032



4

maner ergonomic cauciucat pentru o prindere confortabilă și sigură

blocare rotație

eliberare rapidă mecanism strat protector

siguranța comutator de operare

piulițe de strângerea roților



**SHARE  
20V**

Viteză  
fără povară  
**10000 min<sup>-1</sup>**

masa  
fara baterie  
**1 kg**

excentricitate  
rotile  
**5 mm**

preçnik  
toçkovi  
**125 mm**

**SHARE  
20V  
Li-ion  
technology**

**accesorii recomandate**

- 2 Ah - 28080
- acumulator\* 4 Ah - 28081
- 8 Ah - 28083
- 2,4 A - 28085
- încărcător\* 4,0 A - 28086



**SLEFUITOR ORBITAL CU BATERIE**



\*bateria nu este inclusa

| Nu.   | specificatie |
|-------|--------------|
| 28040 |              |



**SHARE  
20V**

Un numar de  
oscilații  
fara sarcina  
**5000-15000 min<sup>-1</sup>**

masa  
fara baterie  
**1 kg**

viteză control



**SHARE  
20V  
Li-ion  
technology**

**accesorii recomandate**

- 2 Ah - 28080
- acumulator\* 4 Ah - 28081
- 8 Ah - 28083
- 2,4 A - 28085
- încărcător\* 4,0 A - 28086



**DISPOZITIV FĂRĂ FIR MULTIFUNCȚIONAL**



\*bateria nu este inclusa

| Nu.   | specificatie |
|-------|--------------|
| 28045 |              |



**SHARE**  
**20V**



viteză fara sarcina  
**3650 min<sup>-1</sup>**

reglabil unghi de înclinare a tăieturii **45-90 de grade**

max. diametru rotile  
**165 mm**  
(ø16 mm)

tăiere maximă  
**50 mm**  
\* la un unghi de 90 de grade ø165 mm



**SHARE**  
**20V**  
**Li-ion**  
technology

**accesorii recomandate**

- 2 Ah - 28080
- acumulator\* 4 Ah - 28081
- 8 Ah - 28083
- 2,4 A - 28085
- încărcător\* 4,0 A - 28086



**FERĂSTRĂU CIRCULAR FĂRĂ FIR**

Setul contine:

- Fierăstrău circular
- ghidaj lateral
- cheie
- lama de ferastrau ø 165 x 2,8/2,0 x 20 mm 24T (**22314**)



Nu. specificatie

28035



**SHARE  
20V**

numărul de curse  
ale lamei

0-2400 min<sup>-1</sup>

masa  
fara baterie  
1,8 kg

max. unghi  
tăietură teșită  
45 de grade

max. a tăia  
profil  
oțel: 6 mm  
lemn: 80 mm

**accesorii recomandate**

- 2 Ah - 28080
- acumulator\* 4 Ah - 28081
- 8 Ah - 28083
- 2,4 A - 28085
- încărcător\* 4,0 A - 28086



**SHARE  
20V  
Li-ion  
technology**

**FESTA  
POWER X TOOLS**

**PUZZLE FĂRĂ FIR**



\*bateria nu este inclusa

| Nu.   | specificatie |
|-------|--------------|
| 28050 |              |

maner ergonomic cauciucat pentru  
o prindere confortabilă și sigură

siguranța  
comutator de operare

pre-oscilatie  
setare

LED

blocarea barei

șină de ghidare

baza

laba  
blocarea pantei

teșit tăietura  
0°  
45° 45°

**SHARE  
20V**

Un numar de  
oscilații fără  
sarcină

0-3000 min<sup>-1</sup>

masa  
fara baterie  
1,7 kg

max. grosimeade tăiere  
Lemn: 100 mm  
Oțel: 5 mm  
aluminu/cupru: 20 mm

**accesorii recomandate**

- 2 Ah - 28080
- acumulator\* 4 Ah - 28081
- 8 Ah - 28083
- 2,4 A - 28085
- încărcător\* 4,0 A - 28086



**SHARE  
20V  
Li-ion  
technology**

**FESTA  
POWER X TOOLS**

**FERĂSTRĂU ALTERNATIV FĂRĂ FIR**



\*bateria nu este inclusa

| Nu.   | specificatie |
|-------|--------------|
| 28055 |              |

siguranța  
comutator de operare

maner ergonomic cauciucat  
pentru o prindere confortabilă  
și sigură

eliberare rapidă  
lamă de ferăstrău



**SHARE**  
**20V**

max. presiune  
**8,2 bar**

manometru  
psi, bar,  
kgf/cm<sup>2</sup>, kPa

furtun  
**600 mm**

voltaj  
**20 V**

display manometru  
iluminat din spate



soft  
grip

maner ergonomic  
cauciucat pentru  
o prindere confortabilă și sigură

mandrina cu  
eliberare rapida  
pentru umflarea  
anelor

baterie auto  
adaptor  
3 m



adaptoare

Setul contine:  
- compresor  
- adaptor de alimentare de la bateria auto  
- 3x adaptoare de umflare

furtun  
Ø 10,5 x 600 mm

Lumina LED



**accesorii recomandate**

**SHARE**  
**20V**  
*Li-ion*  
technology

2 Ah - 28080  
acumulator\* 4 Ah - 28081  
8 Ah - 28083  
2,4 A - 28085  
încărcător\* 4,0 A - 28086



**FESTA**  
POWER X TOOLS

**COMPRESOR DE AER**

\*bateria nu este inclusa

| Nu.   | specificatie  |
|-------|---------------|
| 28075 |               |
| 48013 | NEW adaptoare |



1  
1



**NEW**

poziție orizontală  
110 kg

poziție verticală  
80 kg

Ø 220 mm

USB-C



**FESTA**  
POWER X TOOLS

VENTUZĂ AKU

|          |       |        |               |       |                    |
|----------|-------|--------|---------------|-------|--------------------|
| Ø 220 mm | 80 kg | 110 kg | ROUGH SURFACE | USB-C | Li-ion 3.6V<br>2Ah |
|----------|-------|--------|---------------|-------|--------------------|

Nu. 36326

specificație

1

**SHARE 20V**

capacitate încărcare  
60 kg

vibrație  
12 niveluri de ajustare,  
3500 - 8500 r/min

masă  
3 kg

voltaj  
20 V

maner ergonomic  
cauciucat pentru o  
prindere confortabilă și sigură



display iluminat



pârghia de blocare a  
ventuzei



Ventuză diametru  
Ø 125 mm



accesorii recomandate

**SHARE 20V**  
Li-ion technology

- 2 Ah - 28080
- acumulator\* 4 Ah - 28081
- 8 Ah - 28083
- încărcător\* 2,4 A - 28085
- 4,0 A - 28086

Setul conține:  
- vibrator faianta  
- baterie 2,0 Ah (doar 36328)  
- încărcător (doar 36328)  
- caz

**FESTA**  
POWER X TOOLS

VENTUZA VIBRATOARE  
PENTRU NIVELARE PLACI CERAMICE

| Nu.   | specificație                    |   |
|-------|---------------------------------|---|
| 36328 | cu acumulator 2Ah si incarcator | 1 |
| 36329 | fara baterie si incarcator      | 1 |



**SHARE**  
**20V**

viteza reglabila  
0-8,7 mm/s

masa  
1,7 kg

cuplu  
6500 N

voltaj  
20 V

**accesorii recomandate**

**SHARE**  
**20V**  
*Li-ion*  
technology

2 Ah - 28080  
acumulator\* 4 Ah - 28081  
8 Ah - 28083  
2,4 A - 28085  
încărcător\* 4,0 A - 28086



declanșare cu  
viteză variabilă

Lumina LED

maner ergonomic  
cauciucat pentru o  
prindere conforta-  
bilă și sigură



**PISTOL DE CALAFAT**

\*bateria nu este inclusa

| Nu.   | specificație |
|-------|--------------|
| 28060 |              |



1



**CARTUȘ DE ETANȘARE DE REZERVĂ**  
- for 28060

| Nu.   | specificație |
|-------|--------------|
| 28061 | 600 ml       |



600 ml



1

**SHARE**  
**20V**

temperatura de  
culoare  
5000 K

masa  
fara baterie  
0,9 kg

flux luminos  
2000 lm (100%)

putere LED  
20W



**LUMINA LED AKU**

|     |            |      |        |
|-----|------------|------|--------|
| 20W | 2000 lumen | IP20 | 0.9 kg |
|-----|------------|------|--------|

\*bateria nu este inclusa

| Nu.   | specificație |
|-------|--------------|
| 28065 |              |



**SHARE**  
**20V**  
*Li-ion*  
technology

**accesorii recomandate**

2 Ah - 28080  
acumulator\* 4 Ah - 28081  
8 Ah - 28083  
2,4 A - 28085  
încărcător\* 4,0 A - 28086



setarea intensității luminii  
50%, 100%



reglare cap pivotant la 360°



2

**SHARE  
20V**

- tuner  
DAB+ / FM / BT
- putere  
2x 15 W
- voltaj  
20 V
- rezistența la  
patrundera apei  
IP54



USB  
pentru încărcare 5V



baterie **SHARE  
20V**

Antena FM



color display

**accesorii recomandate**

**SHARE  
20V**  
*Li-ion  
technology*

- 2 Ah - 28080
- acumulator\* 4 Ah - 28081
- 8 Ah - 28083
- 2,4 A - 28085
- încărcător\* 4,0 A - 28086



AUX IN jack 3,5 mm



difuzoare stereo

alimentare - adaptor 230V



**FESTA  
POWER X TOOLS**

**RADIO DAB+ / FM / BT**

- stereo
- DAB+ / FM
- intrare externă Bluetooth V5.0 / AUX IN jack de 3,5 mm
- rezistența la patrundera apei IP54
- 30 de memorie presetate (30 pentru DAB / 30 pentru FM)
- USB pentru încărcare
- Afișaj color de 2,4"
- putere 2x 15 W
- 20 V / 1,3 A
- adaptor de alimentare

\*bateria nu este inclusă



**SHARE**  
**20V**



**ÎNCĂRCĂTOR 20 V I 2,4 A**

| Nu.   | specificație                  |
|-------|-------------------------------|
| 28085 | 220 – 240 V, 50 – 60 Hz, 70 W |



**SHARE**  
**20V**



**ÎNCĂRCĂTOR 20 V I 4,0 A**

| Nu.   | specificație                    |
|-------|---------------------------------|
| 28086 | *220 – 240 V, 50 – 60 Hz, 105 W |



**SHARE** *Li-ion technology*  
**20V**



indicator de încărcare a bateriei

**BATERIE 20 V I 2,0 Ah**

|     |        |        |        |
|-----|--------|--------|--------|
| 20V | 2,0 Ah | Li-ion | KG 0,4 |
|-----|--------|--------|--------|



| Nu.   | specificație |
|-------|--------------|
| 28080 |              |



**SHARE** *Li-ion technology*  
**20V**



indicator de încărcare a bateriei

**BATERIE 20 V I 4,0 Ah**

|     |        |        |        |
|-----|--------|--------|--------|
| 20V | 4,0 Ah | Li-ion | KG 0,7 |
|-----|--------|--------|--------|



| Nu.   | specificație |
|-------|--------------|
| 28081 |              |



**SHARE** *Li-ion technology*  
**20V**



**NEW**



indicator de încărcare a bateriei

**BATERIE 20 V I 8,0 Ah**

|     |        |        |        |
|-----|--------|--------|--------|
| 20V | 8,0 Ah | Li-ion | KG 1,0 |
|-----|--------|--------|--------|



| Nu.   | specificație |
|-------|--------------|
| 28083 |              |



**SHARE**  
**20V** *Li-ion*  
*technology*

28080



28085



REDUCERE  
**PRET**

**FESTA**  
POWER X TOOLS

### SET FĂRĂ FĂRĂ CU SET SACĂ 2+3

28080 - Baterie pentru scule cu acumulator FESTA SHARE20V 2,0 Ah  
28085 - Încărcător FESTA SHARE20V 2,4 A

| Nu.   | specificatie |   |
|-------|--------------|---|
| 28090 |              | 1 |

**SHARE**  
**20V** *Li-ion*  
*technology*

28004  
pagina 628025  
pagina 9

37330

28030  
pagina 12**BRUSHLESS**

REDUCERE  
**PRET**  
+GEANT GRATUIT

**FESTA**  
POWER X TOOLS

### SET FĂRĂ FĂRĂ CU SET SACĂ 3+3

28004 - Burghiu fara fir cu ciocan FESTA SHARE20V  
28025 - Ciocan de foraj FESTA SDS+ SHARE20V  
28030 - Polizor unghiular fara fir FESTA "BRUSHLES" SHARE20V 125 mm  
28080 - Baterie pentru scule cu acumulator FESTA SHARE20V 2,0 Ah  
28081 - Baterie pentru scule cu acumulator FESTA SHARE20V 4,0 Ah  
28086 - Încărcător FESTA SHARE20V 4,0 A

28080  
pagina 1828081  
pagina 1828086  
pagina 18

| Nu.   | specificatie |   |
|-------|--------------|---|
| 28102 |              | 1 |

**BRUSHLESS** **SHARE**  
**20V** *Li-ion*  
*technology*

28002  
pagina 5

37330

28030  
pagina 12

REDUCERE  
**PRET**  
+GEANT GRATUIT

**FESTA**  
POWER X TOOLS

### SET FĂRĂ FĂRĂ CU SET SACĂ 2+3

28002 - Burghiu fara fir cu ciocan FESTA SHARE20V  
28030 - Polizor unghiular fara fir FESTA "BRUSHLES" SHARE20V 125 mm  
28080 - Baterie pentru scule cu acumulator FESTA SHARE20V 2,0 Ah  
28081 - Baterie pentru scule cu acumulator FESTA SHARE20V 4,0 Ah  
28086 - Încărcător FESTA SHARE20V 4,0 A

28080  
pagina 1828081  
pagina 1828086  
pagina 18

| Nu.   | specificatie |   |
|-------|--------------|---|
| 28103 |              | 1 |

**SHARE**  
**20V** *Li-ion*  
*technology*

28004  
pagina 6

28032  
pagina 12

28055  
pagina 15

REDUCERE  
**PRET**  
+GEANT GRATUIT

28035  
pagina 14

37330

28040  
pagina 13

**FESTA**  
POWER X TOOLS

**SET FĂRĂ FĂRĂ CU SET SACĂ 5+3**

- 28004 - Burghiu fara fir cu ciocan FESTA SHARE20V
- 28032 - Polizor unghiular fara fir FESTA SHARE20V 115 mm
- 28035 - Ferăstrău circular fără fir FESTA SHARE20V 165 mm/d 16 mm
- 28040 - Polizor excentric FESTA SHARE20V 125 mm 8 otv.
- 28055 - Ferăstrău fără fir FESTA SHARE20V
- 28080 - Baterie pentru scule cu acumulator FESTA SHARE20V 2,0 Ah
- 28081 - Baterie pentru scule cu acumulator FESTA SHARE20V 4,0 Ah
- 28086 - Încărcător FESTA SHARE20V 4,0 A



28080  
pagina 18



28081  
pagina 18



28086  
pagina 18



Nu. specificatie

28101



1

**SHARE**  
**20V** *Li-ion*  
*technology*

**BRUSHLESS**

28002  
pagina 5

28030  
pagina 12

REDUCERE  
**PRET**  
+GEANT GRATUIT

28040  
pagina 13

**BRUSHLESS**

37330

28055  
pagina 15

28035  
pagina 14

**FESTA**  
POWER X TOOLS

**SET FĂRĂ FĂRĂ CU SET SACĂ 5+3**

- 28002 - Burghiu fara fir cu ciocan FESTA SHARE20V
- 28030 - Polizor unghiular fara fir FESTA "BRUSHLES" SHARE20V 125 mm
- 28035 - Ferăstrău circular fără fir FESTA SHARE20V 165 mm/d 16 mm
- 28040 - Polizor excentric FESTA SHARE20V 125 mm 8 otv.
- 28055 - Ferăstrău fără fir FESTA SHARE20V
- 28080 - Baterie pentru scule cu acumulator FESTA SHARE20V 2,0 Ah
- 28081 - Baterie pentru scule cu acumulator FESTA SHARE20V 4,0 Ah
- 28086 - Încărcător FESTA SHARE20V 4,0 A

28080  
pagina 18



28081  
pagina 18



28086  
pagina 18



Nu. specificatie

28104





1

**BRUSHLESS**

instrumentul este alimentat  
motor DC fără perii

cuplu 

viteză 

direcție selectabilă  
de rotație 

chuck 

găurire, găurire cu ciocan,  
înșurubarea 

numărul de lovituri pe minut 

găurire, înșurubare 

masa  
cu/fara baterie 

metoda de atasare 

metoda de atasare 

metoda de atasare 

excentricitatea discului 

controlul dispozitivului pentru  
mâna dreaptă și stângă 

îndeplinește acel standard 

flux luminos 

unghiul de direcție al luminii 

frecvența maximă  
de tragere 

**SHARE  
20V**

instrumentul este compatibil  
cu atât baterie

 tipuri adecvate de unghii

 tipuri adecvate de catarama

 piatră de polizor  
cu gauri

 diametrul maxim al roții

 diametrul roții

 grosimea maximă de tăiere  
material: lemn

 grosimea maximă de tăiere  
material: lemn

 setare pre-oscilație

 atașamentul ferăstrăului

 numărul de curse ale lamei  
numărul de curse ale lamei

 posibilitate de  
teșit a tăia

 eliberare rapidă a pânzei  
de ferăstrău

 numărul de oscilații a ferăstrăului

 iluminare LED

 capacitatea bateriei

 baterie

 timp de incarcare  
baterie



**NEW**

viteza  
520 min<sup>-1</sup>

BPM / Forța de impact  
0 - 4100 / 12 J

putere  
1500 W

cap  
de prindere  
SDS MAX



MAX ø beton - ø 40 mm



opritor  
de adâncime

reducerea vibrațiilor  
sistem

maner ergonomic  
cauciucat pentru o  
prindere  
confortabilă și  
sigură



colector de praf

prindere SDS MAX  
capul sculei



mâner suplimentar



**FESTA**  
POWER X TOOLS

**BURGHIU CU CIOCAN  
SDS MAX**

Setul contine:

- burghiu cu ciocan
- maner lateral
- calibre de adâncime
- colector de praf
- cheie
- Cutie de plastic
- perii de cărbune de rezervă
- accesorii SDS MAX:

ø 16 x 280 mm  
| 18 x 320 mm

perii de cărbune  
de rezervă 2 buc

- 28229



|                |       |             |                      |     |            |              |           |                       |  |
|----------------|-------|-------------|----------------------|-----|------------|--------------|-----------|-----------------------|--|
| 230V<br>~ 50Hz | 1500W | 4100<br>bpm | 520min <sup>-1</sup> | 12J | SDS<br>MAX | 3m<br>RUBBER | 6.8<br>kg | MAX ø40mm<br>Concrete |  |
|----------------|-------|-------------|----------------------|-----|------------|--------------|-----------|-----------------------|--|

Nu. specificatie  
28221

**FESTA**  
POWER X TOOLS



viteza  
0-850 min<sup>-1</sup>

BPM / Forța de impact  
0-4500 / 6 J

putere  
1500 W

cap  
de prindere  
SDS+



MAX Ø

beton - ø 32 mm  
otel - ø 13 mm  
lemn - ø 40 mm



opritor  
de adâncime

reducerea vibrațiilor  
sistem

prindere SDS  
capul sculei

maner ergonomic  
cauciucat pentru o  
prindere  
confortabilă și  
sigură

mâner suplimentar



2.0m

**FESTA**  
POWER X TOOLS

**BURGHIU CU CIOCAN**

- Setul contine:
- burghiu cu ciocan
  - maner lateral
  - calibre de adâncime
  - cheie
  - Cutie de plastic
  - perii de cărbune de rezervă
  - accesorii SDS+:

- ø 8, 10, 12 x 160 mm
- 20 x 250 mm
- 14 x 250 mm



|                |       |               |                         |    |      |              |           |
|----------------|-------|---------------|-------------------------|----|------|--------------|-----------|
| 230V<br>~ 50Hz | 1500W | 0-4500<br>bpm | 0-850 min <sup>-1</sup> | 6J | SDS+ | 2m<br>RUBBER | 5.0<br>KG |
|----------------|-------|---------------|-------------------------|----|------|--------------|-----------|

perii de cărbune  
de rezervă 2 buc

- 28228



viteza  
0-1350 min<sup>-1</sup>

BPM / Forța de impact  
0-5500 / 2,8 J

putere  
800 W

cap  
de prindere  
SDS+  
ø 2 - 13 mm



MAX ø beton - ø 25 mm  
otel - ø 13 mm  
lemn - ø 30 mm



**FESTA**  
POWER X TOOLS

**BURGHIU CU CIOCAN**

- Setul contine:
- burghiu cu ciocan
  - maner lateral
  - calibre de adâncime
  - mandrina ø 2 - 13 mm
  - Cutie de plastic
  - vaselina
  - perii de cărbune de rezervă
  - accesorii SDS+:

- ø 6, 8, 10 x 160 mm
- 20 x 250 mm
- 14 x 250 mm



|                |      |            |                          |      |      |           |     |
|----------------|------|------------|--------------------------|------|------|-----------|-----|
| 230V<br>~ 50Hz | 800W | 0-5500 bpm | 0-1350 min <sup>-1</sup> | 2.8J | SDS+ | 2m RUBBER | 3.2 |
|----------------|------|------------|--------------------------|------|------|-----------|-----|

perii de cărbune de rezervă 2 buc - 28223



viteză  
fara sarcina  
**0-4500 min<sup>-1</sup>**

masa  
**4,3 kg**

putere  
**1400 W**

max.  
diametru roțile  
**max ø 185 mm/  
ø 20 mm**



max. 63 mm



maner ergonomic  
cauciucat  
pentru o prindere  
confortabilă și  
sigură



max. 45°

șină de ghidare  
6 - 120 mm



extragerea prafului  
ø 35 mm

2.0m



**FERĂSTRĂU CIRCULAR**

Setul contine:

- Fierăstrău circular
- ghidaj lateral
- cheie
- perii de cărbune de rezervă
- lama de ferăstrău ø 185 x 2,3/1,3 x 20 mm 24T (22316)



22316

|              |                       |                              |                     |             |                     |                         |
|--------------|-----------------------|------------------------------|---------------------|-------------|---------------------|-------------------------|
| <b>1400W</b> | <b>230V</b><br>~ 50Hz | <b>4500 min<sup>-1</sup></b> | <b>ø 20</b><br>1 mm | <b>90°</b>  | <b>45°</b><br>42 mm | <b>KG</b><br><b>4.3</b> |
|              |                       |                              | <b>MAX 185mm</b>    | <b>63mm</b> |                     |                         |

perii de cărbune  
de rezervă 2 buc

- 28233



Nu. specificatie

28230

viteza  
**6600 min<sup>-1</sup>**

masa  
**5,8 kg**

putere  
**2400 W**

maximal  
diametrul roții  
**M14**  
**max ø 230 mm**



ergonomic rubberized handle for a comfortable and secure grip

## SOFT START

Pornire soft electronică

siguranța comutator de operare



husa de protecție

mâner rotativ



**FESTA**  
POWER X TOOLS

### POLIZOR UNGHIULAR

- Setul conține:
- polizor unghiular
  - paza de protecție
  - mâner lateral
  - cheie
  - perii de cărbune de rezervă

|              |                       |  |            |                    |                       |                  |
|--------------|-----------------------|--|------------|--------------------|-----------------------|------------------|
| <b>2400W</b> | <b>230V</b><br>~ 50Hz | <b>6600 min<sup>-1</sup></b><br>SOFT START | <b>M14</b> | <b>max ø 230mm</b> | <b>2.0m</b><br>RUBBER | <b>5.8</b><br>KG |
|--------------|-----------------------|--|------------|--------------------|-----------------------|------------------|



perii de cărbune de rezervă 2 buc

- 28218



Nu. specificaties

28215

2

viteza  
**11000 min<sup>-1</sup>**

masa  
**2 kg**

putere  
**900 W**

maximal  
diametrul roții  
**M14**  
**max ø 125 mm**

mâner suplimentar



siguranța  
comutator de operare

**SOFT START**  
Pornire soft electronică



husa de protecție

**FESTA**  
POWER X TOOLS

**POLIZOR UNGHIULAR**

- Setul conține:
- polizor unghiular
  - paza de protecție
  - mâner lateral
  - cheie
  - perii de cărbune de rezervă



|             |                       |                              |            |                    |                    |               |  |  |  |
|-------------|-----------------------|------------------------------|------------|--------------------|--------------------|---------------|--|--|--|
| <b>900W</b> | <b>230V</b><br>~ 50Hz | <b>11000min<sup>-1</sup></b> | <b>M14</b> | <b>max ø 125mm</b> | <b>2.0m RUBBER</b> | <b>KG 2.0</b> |  | perii de cărbune de rezervă 2 buc - <b>28213</b> |  |
|-------------|-----------------------|------------------------------|------------|--------------------|--------------------|---------------|--|--|--|

| Nu.          | specificatii |          |
|--------------|--------------|----------|
| <b>28210</b> |              | <b>8</b> |

**FESTA**  
POWER X TOOLS

**PERII DE CĂRBUNE DE REZERVĂ**

**2x**



| Nu.          | specificatii |   |
|--------------|--------------|---|
| <b>28229</b> | pentru 28221 | 1 |
| <b>28228</b> | pentru 28225 | 1 |
| <b>28223</b> | pentru 28220 | 1 |
| <b>28233</b> | pentru 28230 | 1 |
| <b>28213</b> | pentru 28210 | 1 |
| <b>28218</b> | pentru 28215 | 1 |



**ADAPTOR SDS MAX / SDS +**

|                              |              |
|------------------------------|--------------|
| <b>SDS MAX</b> → <b>SDS+</b> |              |
| Nu.                          | specificație |
| 20744                        | 1            |



**ADAPTOR SDS+ / 1/2 UNF**

|             |              |
|-------------|--------------|
| <b>SDS+</b> |              |
| Nu.         | specificație |
| 20745       | 1            |



**FESTA**

**ADAPTER SDS + TO BIT 1/4"**

|               |              |
|---------------|--------------|
| <b>SDS+</b> → |              |
| Nu.           | Specificație |
| 20743         | 75 mm        |
|               | 20           |



**FESTA**

**MANDRINA CU CHEIE**

|             |                                 |
|-------------|---------------------------------|
| <b>1/2"</b> |                                 |
| Nu.         | specificație                    |
| 20960       | 1-13 mm + 2 clișe, 1/2 - 20 UNF |
| 20966       | năhradní klíček                 |
|             | 3                               |
|             | 25                              |



**FESTA**

**MANDRINA RAPIDA**

|             |                           |
|-------------|---------------------------|
| <b>1/2"</b> |                           |
| Nu.         | specificație              |
| 20965       | 1,5 - 13 mm 1/2' - 20 UNF |
|             | 1                         |



**MANDRINA RAPIDA**

|             |                           |
|-------------|---------------------------|
| <b>1/2"</b> |                           |
| Nu.         | specificație              |
| 20961       | 1,5 - 13 mm 1/2' - 20 UNF |
|             | 1                         |



**ADAPTOR PENTRU GAURIRE LA 90°**

|       |              |
|-------|--------------|
| Nu.   | specificație |
| 20365 | Ø 1 - 10 mm  |
|       | 10           |



**MANDRINĂ STRÂNGERE RAPIDĂ ÎN AKU**

|       |              |
|-------|--------------|
|       |              |
| Nu.   | specificație |
| 20963 | Ø 1 - 6 mm   |
|       | 10           |



**FESTA**

**EXTRACTOR DE PRAF**

|       |              |
|-------|--------------|
| Nu.   | specificație |
| 28267 | max. 70 mm   |
|       | 1            |

**MASINA DE GHIDARE**

|       |                            |
|-------|----------------------------|
| Nu.   | specificație               |
| 20379 | Ø 4, 5, 6, 7, 8, 10, 12 mm |
|       | 10                         |

TEHNIC  
SPECIFICAȚIE

| NUMĂR DE CATALOG PRODUSE                         | 28000  | 28001  | 28002  | 28003   | 28004  |
|--|--|--|--|---|--|
| Nume   | Burghiu cu ciocan cu acumulator  | Burghiu cu ciocan cu acumulator  | Burghiu cu ciocan cu acumulator                          | Burghiu cu ciocan cu acumulator   | Burghiu cu ciocan cu acumulator                          |
| Viteză fără sarcină                              | I.0-550 min <sup>-1</sup><br>II.0-2000 min <sup>-1</sup>   | I.0-550 min <sup>-1</sup><br>II.0-2000 min <sup>-1</sup>                         | I.0-550 min <sup>-1</sup><br>II.0-2000 min <sup>-1</sup> | I.0-500 min <sup>-1</sup><br>II.0-1800 min <sup>-1</sup>                                    | I.0-500 min <sup>-1</sup><br>II.0-1800 min <sup>-1</sup> |
| Numărul de accesări                              | I.0-8800min <sup>-1</sup><br>II.0-32000min <sup>-1</sup>   | I.0-8800min <sup>-1</sup><br>II.0-32000min <sup>-1</sup>                         | I.0-8800min <sup>-1</sup><br>II.0-32000min <sup>-1</sup> | 0-19200 min <sup>-1</sup>   | 0-19200 min <sup>-1</sup>                                |
| Numărul de lovituri                              |  |  |  |   |  |
| Cuplu  | 80 Nm  | 80 Nm  | 80 Nm  | 45 Nm   | 45 Nm  |
| Max. tensiunea bateriei                          | 20V  | 20V  | 20V  | 20V   | 20V  |
| Numărul de etape cuplu                           | 20+1+1   | 20+1+1   | 20+1+1   | 19+1+1  | 19+1+1   |
| Cap de prindere                                  | 2-13 mm  | 2-13 mm  | 2-13 mm  | 2-13 mm   | 2-13 mm  |
| Greutate fara baterie                            | 1,4kg  | 1,4kg  | 1,4kg  | 1,3kg   | 1,3kg  |
| Acoperi  | IPX0   | IPX0   | IPX0   | IPX0  | IPX0   |
| Nivelul de presiune al sunetului incertitudine K | LpA=97,04dB(A)<br>K=5dB(A)   | LpA=97,04dB(A)<br>K=5dB(A)   | LpA=97,04dB(A)<br>K=5dB(A)                               | LpA=79dB(A)<br>K=5dB(A)   | LpA=79dB(A)<br>K=5dB(A)                                  |
| Nivel de putere sonoră incertitudine K           | LwA=86,04dB(A)<br>K=5dB(A)   | LwA=86,04dB(A)<br>K=5dB(A)   | LwA=86,04dB(A)<br>K=5dB(A)                               | LwA=90dB(A)<br>K=5dB(A)   | LwA=90dB(A)<br>K=5dB(A)                                  |
| Vibrație fără lovire în metal                    | $\alpha_{h,D}=3,9m/s^2$<br>K=1,5m/s <sup>2</sup>   | $\alpha_{h,D}=3,9m/s^2$<br>K=1,5m/s <sup>2</sup>                                 | $\alpha_{h,D}=3,9m/s^2$<br>K=1,5m/s <sup>2</sup>         | $\alpha_{h,D}=2,4m/s^2$<br>K=1,5m/s <sup>2</sup>  | $\alpha_{h,D}=2,4m/s^2$<br>K=1,5m/s <sup>2</sup>         |
| Vibrație fără lovire în beton                    | $\alpha_{h,D}=11,4m/s^2$<br>K=1,5m/s <sup>2</sup>  | $\alpha_{h,D}=11,4m/s^2$<br>K=1,5m/s <sup>2</sup>                                | $\alpha_{h,D}=11,4m/s^2$<br>K=1,5m/s <sup>2</sup>        | $\alpha_{h,D}=7,5m/s^2$<br>K=1,5m/s <sup>2</sup>  | $\alpha_{h,D}=7,5m/s^2$<br>K=1,5m/s <sup>2</sup>         |
| Vibrație maximă, incertitudine K                 |  |  |  |   |  |
| Forța de lovitură                                |  |  |  |   |  |
| Diametrul de gaurire                             |  |  |  |   |  |
| Vibrații în beton -mâner principal               |  |  |  |   |  |
| Vibrații în beton - mâner suplimentar            |  |  |  |   |  |
| Conținutul pachetului                            | burghiu,<br>2,4 A încărcător,<br>baterie 2.0 Ah,<br>baterie de 4,0 Ah,<br>mâner suplimentar,<br>valiză | burghiu, încărcător<br>2,4 A,<br>baterie 2.0 Ah,<br>mâner suplimentar,<br>valiză | burghiu  | burghiu,<br>2,4 A încărcător,<br>2x 2.0 Ah baterie,<br>6x bit, carrier,<br>6x drill, valiză | burghiu  |





| 28005   | 28006  | 28007  | 28008  | 28021   | 28025   |
|---|--|--|--|---|---|
| Găuriți șurubelniță fără fir  | Găuriți șurubelniță fără fir                             | Găuriți șurubelniță fără fir   | Șurubelniță fără fir   | Cheie de impact fără fir                            | Burghiu fara fir cu ciocan                                    |
| I.0-350 min <sup>-1</sup><br>II.0-1300 min <sup>-1</sup>                                      | I.0-350 min <sup>-1</sup><br>II.0-1300 min <sup>-1</sup> | I.0-350 min <sup>-1</sup><br>II.0-1300 min <sup>-1</sup>                                     | 200 min <sup>-1</sup>  | 0-2000 min <sup>-1</sup>                            | I.0-300 min <sup>-1</sup><br>II.0-1000 min <sup>-1</sup>      |
|   |  |  |  |   | 0-5000bpm   |
|   |  |  |  | 0-3000bpm   |   |
| 28 Nm   | 28 Nm  | 20 Nm  | 3 Nm   | 150 Nm  |   |
| 20V   | 20V  | 12V  | 3.6V   | 20V   | 20V   |
| 19+1  | 19+1   | 19+1   | 6+1  |   |   |
| 1-10mm  | 1-10mm   | 1-10mm   | 1/4" hexagon   | 1/4" hexagon  | SDS+  |
| 0,9kg   | 0,9kg  | *1kg   | *0,4kg   | 1,2kg   | 1,7kg   |
| IPX0  | IPX0   | IPX0   | IPX0   | IPX0  | IPX0  |
| LpA=69dB(A)<br>K=5dB(A)   | LpA=69dB(A)<br>K=5dB(A)                                  | LpA=78dB(A)<br>K=5dB(A)  | LpA=58dB(A)<br>K=3dB(A)  | LpA=92dB(A)<br>K=3dB(A)                             | LpA=82,98dB(A)<br>K=3dB(A)                                    |
| LwA=80dB(A)<br>K=5dB(A)   | LwA=80dB(A)<br>K=5dB(A)                                  | LwA=67dB(A)<br>K=5dB(A)  | LwA=69dB(A)<br>K=3dB(A)  | LwA=103dB(A)<br>K=3dB(A)                            | LwA=93,98dB(A)<br>K=3dB(A)                                    |
| $\alpha_{h,D} < 1,9m/s^2$<br>K=1,5m/s <sup>2</sup>  | $\alpha_{h,D} < 1,9m/s^2$<br>K=1,5m/s <sup>2</sup>       | $\alpha_{h,D} = 2,1m/s^2$<br>K=1,5m/s <sup>2</sup>   |  |   |   |
| $\alpha_{h,D} = 10,1m/s^2$<br>K=1,5m/s <sup>2</sup>   | $\alpha_{h,D} = 10,1m/s^2$<br>K=1,5m/s <sup>2</sup>      | $\alpha_{h,D} = 7,5m/s^2$<br>K=1,5m/s <sup>2</sup>   |  |   |   |
|   |  |  | $\alpha_h < 2,5m/s^2$<br>K=1,5m/s <sup>2</sup>                 | $\alpha_{h,D} = 15,9m/s^2$<br>K=1,5m/s <sup>2</sup> |   |
|   |  |  |  |   | 1,2J  |
|   |  |  |  |   | Oțel: 10mm<br>concrete: 20mm<br>Lemn: 20mm                    |
|   |  |  |  |   | $\alpha_{h,(HD)} = 5,582m/s^2$<br>K=1,5m/s <sup>2</sup>       |
|   |  |  |  |   | $\alpha_{h,(HD)} = 5,523m/s^2$<br>K=1,5m/s <sup>2</sup>       |
| burghiu,<br>2.4 A încărcător,<br>2x 2.0 Ah baterie,<br>6x bit, carrier,<br>6x burghiu, valiză | burghiu  | drill,<br>2.4 A încărcător,<br>2x 1.5 Ah Baterie,<br>6x bits, carrier,<br>6x burghiu, valiză | screwdriver,<br>încărcător 0.5 A,<br>1.5 Ah baterie,<br>5x bit | tightener   | ciocan de foraj,<br>mâner suplimentar,<br>opritor de adâncime |

\* greutatea este indicată inclusiv bateria

TEHNIC  
SPECIFICAȚIE

| NUMĂR DE CATALOG PRODUSE                              | 28030   | 28032   | 28035   | 28040  |
|---|---|---|---|--|
| Nume  | Unghi fără fir polizor                              | Unghi fără fir polizor                              | Circular fără fir a văzut                       | Baterie orbital șlefuitor                      |
| Viteză fără sarcină                                   | 8500 min <sup>-1</sup>                              | 8000 min <sup>-1</sup>                              | 3650 min <sup>-1</sup>                          | 10000 min <sup>-1</sup>                        |
| Numărul de oscilații fără sarcină                     |   |   |   |  |
| Redirecționa  |   |   |   |  |
| Numărul de grade de pre-oscilație                     |   |   |   |  |
| Numărul de pânze ale pânzei de ferăstrău              |   |   |   |  |
| Profil de tăiere maximă                               |   |   |   |  |
| Diametrul maxim al roții                              | 125 mm  | 115 mm  |   |  |
| Disc suport   |   |   |   | 125 mm   |
| 8 orificii de aspirare pe cerc                        |   |   |   | 65 mm  |
| Excentricitatea roții                                 |   |   |   | 5 mm   |
| Dimensiunea firului axului                            | M14   | M14   |   |  |
| Grosimea maximă a materialului tăiat                  | 15 mm   | 15 mm   |   |  |
| Max. tensiunea bateriei                               | 20V   | 20V   | 20V   | 20V  |
| Unghi de taiere reglabil                              |   |   | 0-45°   |  |
| Tăiați la un unghi de 45 °                            |   |   | 35 mm   |  |
| Tăiați la un unghi de 90 °                            |   |   | 50 mm   |  |
| Unghiul de oscilație                                  |   |   |   |  |
| Dimensiunea bazei de măcinare delta                   |   |   |   |  |
| Vibrația viteză control                               |   |   |   |  |
| Atașarea pânzei de ferăstrău                          |   |   |   |  |
| Cursa pânzei de ferăstrău                             |   |   |   |  |
| Dimensiunea plăcii de bază                            |   |   | 28 cm x 13,3 cm                                 |  |
| Greutate fara baterie                                 | 1,6kg   | 1,6kg   | 2,7kg   | 1kg  |
| Diametrul roții                                       |   |   | 165 mm  |  |
| Grosimea corpului roții                               |   |   | 1,4 mm ± 5% mm                                  |  |
| Grosimea SK a lamei lamei                             |   |   | 2,0 ± 5% mm                                     |  |
| Lățimea de tăiere                                     |   |   | 2,3 ± 5% mm                                     |  |
| Diametrul orificiului roții după prindere             |   |   | 16 mm   |  |
| Numărul de dinți disc                                 |   |   | 24  |  |
| Acoperi   | IPX0  | IPX0  | IPX0  | IPX0   |
| Tip unghiile, inaltime x latime x grosime             |   |   |   |  |
| Cataramă-lungime x înălțime x lățime x grosime        |   |   |   |  |
| Max. lungimea Unghiile / clips in covorase moi.       |   |   |   |  |
| Max. lungimea Unghiile / clips into hard mat.         |   |   |   |  |
| Medie / max. frecvența de tragere                     |   |   |   |  |
| Timp de funcționare (baterie 4 AH, complet încărcată) |   |   |   |  |
| Capacitate magazin unghii/capse                       |   |   |   |  |
| Nivelul de presiune al sunetului incertitudine K      | LpA=87,1dB(A)<br>K=3dB(A)                           | LpA=76,67dB(A)<br>K=3dB(A)                          | LpA=84dB(A)<br>K=3dB(A)                         | LpA=76dB(A)<br>K=3dB(A)                        |
| Nivel de putere sonoră incertitudine K                | LwA=98,1dB(A)<br>K=3dB(A)                           | LwA=87,67dB(A)<br>K=3dB(A)                          | LwA=95dB(A)<br>K=3dB(A)                         | LwA=87dB(A)<br>K=3dB(A)                        |
| Vibrații la șlefuirea suprafeței                      | $\alpha_{h,AG}=8,363m/s^2$<br>K=1,5m/s <sup>2</sup> | $\alpha_{h,AG}=5,324m/s^2$<br>K=1,5m/s <sup>2</sup> |   |  |
| Vibrații pentru tăierea plăcii                        |   |   |   |  |
| Vibrații pentru tăierea tablei                        |   |   |   |  |
| Vibrații pentru taiere Lemn:en rame                   |   |   |   |  |
| Vibrație maximă, incertitudine K                      |   |   | $\alpha_h < 2,5m/s^2$<br>K=1,5m/s <sup>2</sup>  | $\alpha_h = 9,5m/s^2$<br>K=1,5m/s <sup>2</sup> |
| Conținutul pachetului                                 | grinder, wheel cover, mâner suplimentar, wrench     | grinder, wheel cover, mâner suplimentar, wrench     | a văzut, opritor de adâncime, lamă de ferăstrău | polizor, sac de colectare a prafului           |



| 28045  | 28050  | 28055  | 28070                                     |
|--|--|--|---|
| Dispozitiv fără fir multifuncțional                                | Puzzle fără fir  | Ferăstrău alternativ fără fir                      | Nailer și capsator fără fir               |
| 5000-15000 min <sup>-1</sup>                                       |  | 0-3000 min <sup>-1</sup>                           |   |
|  | 3+0  | 1°   |   |
|  | 0-2400 min <sup>-1</sup>   |  |   |
|  | Oțel: 6mm, Lemn: 80mm  | Lemn: 100 mm, Oțel: 5 mm, aluminum / copper: 20 mm |   |
|  |  |  |   |
|  |  |  |   |
|  |  |  |   |
|  |  |  |   |
| 20V  |  | 20V  | 20V                                       |
|  | tăietură teșită max. 45 °  |  |   |
|  |  |  |   |
| 3°   |  |  |   |
| 90 mm  |  |  |   |
| Da   |  |  |   |
| universal  |  | universal  |   |
|  |  | 20 mm  |   |
| 1kg  | 1,8kg  | 1,7kg  | 2,7kg                                     |
|  |  |  |   |
|  |  |  |   |
|  |  |  |   |
|  |  |  |   |
| IPX0   | IPX0   | IPX0   | IPX0                                      |
|  |  |  | F, 20-50mm x 1,2mm x 1,0 mm               |
|  |  |  | 6,0mm x 19-40mm x 1,2mm x 1,0mm           |
|  |  |  | 50 mm                                     |
|  |  |  | 30 mm                                     |
|  |  |  | 60/100 min <sup>-1</sup>                  |
|  |  |  | 1 ora                                     |
|  |  |  | 100 bucăți                                |
| LpA=78dB(A)<br>K=3dB(A)  | LpA=88,1dB(A)<br>K=5dB(A)  | LpA=87,33dB(A)<br>K=5dB(A)                         | LpA=79,9dB(A)<br>K=3dB(A)                 |
| LwA=89dB(A)<br>K=3dB(A)  | LwA=99,1dB(A)<br>K=5dB(A)  | LwA=98,33dB(A)<br>K=5dB(A)                         | LwA=90,9dB(A)<br>K=3dB(A)                 |
|  |  |  |   |
|  | $\alpha_{h,B}=3,3m/s^2$<br>$K=1,5m/s^2$<br>$\alpha_{h,M}=4m/s^2$<br>$K=1,5m/s^2$ | $\alpha_{h,B}=21,10m/s^2$<br>$K=1,5m/s^2$          |   |
|  |  | $\alpha_{h,WB}=21,98m/s^2$<br>$K=1,5m/s^2$         |   |
| $\alpha_h=2,8m/s^2$<br>$K=1,5m/s^2$                                |  |  | $\alpha_h=1,39m/s^2$<br>$K=1,5m/s^2$      |
| râșniță, atașamente (fierăstrău, racletă, suport), 3x șmirghel P80 | ferăstrău, Führungsschiene, atașament de aspirație, 2x lama de ferăstrău         | ferăstrău, 2x pânză de ferăstrău                   | cuier/capsator, 200x Unghiile, 200x capse |

TEHNIC  
SPECIFICAȚIE

| NUMĂR DE CATALOG PRODUSE       | 28075   | 36328   | 36329   | 28060             | 28076   |
|--------------------------------|---|---|---|-------------------|---|
| Nume                           | compresor de aer  | ventuza vibratoare pentru nivelare placi ceramice       | ventuza vibratoare pentru nivelare placi ceramice       | pistol de calafat | radio AKU DAB+ / FM / BT                                |
| Manometru                      | psi; bar; kgf/cm <sup>2</sup> ; kPa   |   |   |                   |   |
| Max. Presiune                  | 120 psi / 8,2 bar   |   |   |                   |   |
| Furtun                         | ø 10,5 x 600 mm   |   |   |                   |   |
| Suction cup                    |   | Ø 123 mm  | Ø 123 mm  |                   |   |
| Suction capacity               |   | 60 kg   | 60 kg   |                   |   |
| Vibrație                       |   | 12 niveluri de ajustare<br>3500 - 8500 r/min            | 12 niveluri de ajustare<br>3500 - 8500 r/min            |                   |   |
| Cuplu                          |   |   |   | 6500 N            |   |
| Viteza reglabila               |   |   |   | 0 - 8,7 mm/s      |   |
| Volum                          |   |   |   | 310 ml            |   |
| Tuner                          |   |   |   |                   | DAB+ / FM   |
| Intrare externă                |   |   |   |                   | Bluetooth 5.0,<br>aux IN jack 3,5 mm                    |
| Putere                         |   |   |   |                   | 2 x 15 W  |
| Afișaj                         |   |   |   |                   | color de 2,4"   |
| Power supply                   |   |   |   |                   | adaptor 230 V,<br>acumulator Li-ion<br>FESTA share 20 V |
| Memorie presetate              |   |   |   |                   | 30 (DAB+), 30 (FM)                                      |
| Rezistența la patrunderea apei |   |   |   |                   | IPX54   |
| Masa                           |   | 3 kg  | 3 kg  | 1,7 kg            | 1,3kg   |
| Voltaj                         | 20 V  | 20 V  | 20 V  | 20 V              | 20 V  |
| Conținutul pachetului          | compresor,<br>adaptor de alimentare de la<br>bateria auto,<br>3x adaptoare de umflare | vibrator faianta,<br>baterie 2,0 Ah,<br>încărcător, caz | vibrator faianta,<br>baterie 2,0 Ah,<br>încărcător, caz | pistol de calafat | Radio, adapter<br>230 V                                 |



| NUMĂR DE CATALOG<br>PRODUSE | 28221   | 28225  | 28220   | 28230  | 28210  | 28215  |
|-----------------------------|---|--|---|--|--|--|
| Nume                        | burghiu cu<br>ciocan<br>SDS MAX   | burghiu cu<br>ciocan<br>SDS+   | burghiu cu<br>ciocan  | ferăstrău circular   | polizor<br>unghiular   | polizor<br>unghiular   |
| putere                      | 1 500 W   | 1 500 W  | 800 W   | 1 400 W  | 900 W  | 2 400 W  |
| viteza                      | 0 - 520 min-1   | 0 - 850 min-1  | 0 - 1 350 min-1   | 0 - 4 500 min-1  | 0 - 11 000 min-1   | 0 - 6 600 min-1  |
| BPM                         | 0 - 4 100   | 0 - 4 500  | 0 - 5 500   |  |  |  |
| Forța de impact             | 12 J  | 6 J  | 2,8 J   |  |  |  |
| cap de prindere             | SDS MAX   | SDS+   | SDS+<br>ø 2 - 13 mm   | 20 mm  | M14 / 22,2 mm  | M14 / 22,2 mm  |
| Unghi de tăiere reglabil    |   |  |   | 0 - 45°  |  |  |
| adâncimea de tăiere 45°     |   |  |   | 42 mm  |  |  |
| adâncimea de tăiere 90°     |   |  |   | 63 mm  |  |  |
| max. diametru roțile        |   |  |   | 185 mm   | 125 mm   | 230 mm   |
| masa                        | 6,8 kg  | 5 kg   | 3,2 kg  | 4,3 kg   | 2 kg   | 5,8 kg   |
| Cablu de alimentare         | 3 m l cauciuc   | 2 m l cauciuc  | 2 m l cauciuc   | 2 m l cauciuc  | 2 m l cauciuc  | 2 m l cauciuc  |
| Conținutul pachetului       | burghiu cu ciocan,<br>maner lateral,<br>calibre de<br>adâncime,<br>cheie, cutie de<br>plastic, perii<br>de cărbune de<br>rezervă,<br>accesorii SDS MAX:<br>  ø 16 x 280 mm<br>  18 x 320 mm | burghiu cu ciocan,<br>maner lateral,<br>calibre de<br>adâncime,<br>cheie, cutie de<br>plastic, perii<br>de cărbune de<br>rezervă,<br>accesorii SDS+:<br>  ø 8, 10, 12 x 160 mm<br>  20 x 250 mm<br>  14 x 250 mm | burghiu cu ciocan,<br>maner lateral,<br>calibre de<br>adâncime,<br>mandrina ø 2 - 13<br>mm,<br>cutie de plastic,<br>vaselina, perii de<br>cărbune de rezervă,<br>accesorii SDS+:<br>  ø 6, 8, 10 x 160 mm<br>  20 x 250 mm<br>  14 x 250 mm | Fierăstrău circular,<br>ghidaj lateral,<br>cheie, perii de cărbune<br>de rezervă,<br>lama de ferastrau<br>ø 185 x 2,3/1,3<br>x 20 mm 24T | polizor unghiular,<br>paza de protecție,<br>maner lateral,<br>cheie,<br>perii de cărbune<br>de rezervă | polizor unghiular,<br>paza de protecție,<br>maner lateral,<br>cheie,<br>perii de cărbune<br>de rezervă |

**NEW**

viteza  
1000 - 1850 min<sup>-1</sup>

lungime  
110 - 180 cm

putere  
750 W

diametrul  
roții  
Ø 225 mm



ergonomic  
rubberized  
handle for  
a comfortable  
and secure grip



**FESTA**  
POWER X TOOLS

ȘLEFUITOR PENTRU GIPS-CARTON

|                |      |                            |         |               |
|----------------|------|----------------------------|---------|---------------|
| 230V<br>~ 50Hz | 750W | 1000-1850min <sup>-1</sup> | Ø 225mm | 110-180<br>cm |
| LED            | 4m   | DRYWALL                    |         |               |



Nu. specificatie  
28240

1

**NEW**



**FESTA**  
POWER X TOOLS

**ASPIRATOR 30L**

|                        |                |                    |                                  |             |           |           |
|------------------------|----------------|--------------------|----------------------------------|-------------|-----------|-----------|
| <b>230 V</b><br>~50 Hz | <b>1600 W</b>  | <b>MAX 2000W</b>   | <b>82dB</b>                      | <b>IPX4</b> | <b>3m</b> | <b>5m</b> |
| <b>30L</b>             | <b>WET DRY</b> | <b>AUTO ON-OFF</b> | <b>AUTOMATIC FILTER CLEANING</b> | <b>HEPA</b> |           |           |

| Nu.   | specificatie |   |
|-------|--------------|---|
| 28345 |              | 1 |
| 28346 | filtru HEPA  | 1 |

**NEW**



**WEST BERG**

**ASPIRATOR 30L**

|                        |                |                    |             |                                       |
|------------------------|----------------|--------------------|-------------|---------------------------------------|
| <b>230 V</b><br>~50 Hz | <b>1200 W</b>  | <b>3m</b>          | <b>5m</b>   | <b>SEMI-AUTOMATIC FILTER CLEANING</b> |
| <b>30L</b>             | <b>WET DRY</b> | <b>AUTO ON-OFF</b> | <b>HEPA</b> |                                       |

| Nu.   | specificatie |   |
|-------|--------------|---|
| 28340 |              | 1 |
| 28342 | filtru HEPA  | 1 |

**FESTA**  
 POWER X TOOLS

**AIXER ELECTRIC PENTRU CONSTRUIREA AMESTECURILOR**

|                                  |                  |
|----------------------------------|------------------|
| Intrare                          | 1800 W           |
| Tensiune/frecvență               | 230 V / 50 Hz    |
| Unelte                           | 2                |
| Treapta 1 (turatie la ralanti)   | 0 - 450 ot./min. |
| Treapta a 2 (turatie la ralanti) | 0 - 790 ot./min. |
| Protecție la suprasarcina        | Da               |
| Diametrul coșului de amestecare  | 100 mm           |
| Lungimea măturii                 | 570 mm           |
| Greutate                         | 5,6 kg           |



| Nu.   | specificatie                            |   |
|-------|---|---|
| 35311 | agitator                                | 1 |
| 35318 | carbon de rezervă                       | 1 |
| 35319 | agitatoare de rezervă - pereche (L + R) | 1 |

**FESTA**  
 POWER X TOOLS

**AMESTECĂTOR MATERIALE DE CONSTRUCȚIE, 1600 W**

|                                  |                  |
|----------------------------------|------------------|
| Putere:                          | 1600 W           |
| Tensiune:                        | 230 V   50 Hz    |
| Number of gears:                 | 2                |
| Treapta 1 (turatie la ralanti)   | 0 - 480 ot./min. |
| Treapta a 2 (turatie la ralanti) | 0 - 800 ot./min. |
| Protecție la suprasolicitare:    | Da               |
| Filet tel de mestecare:          | M 14             |
| Diametrul coșului de amestecat:  | 140 mm           |
| Lungimea telului de amestecare:  | 600 mm           |
| Weight:                          | 4,7 kg           |



| Nu.   | specificatie      |   |
|-------|-------------------|---|
| 35310 |                   | 1 |
| 35317 | carbon de rezervă | 1 |

**FESTA**  
 POWER X TOOLS

**AMESTECĂTOR MATERIALE DE CONSTRUCȚIE, 850 W**

|                                  |                  |
|----------------------------------|------------------|
| Putere:                          | 850 W            |
| Tensiune:                        | 230 V   50 Hz    |
| Number of gears:                 | 1                |
| Treapta 1 (turatie la ralanti)   | 0 - 500 ot./min. |
| Treapta a 2 (turatie la ralanti) | -                |
| Protecție la suprasolicitare:    | Da               |
| Filet tel de mestecare:          | M 14             |
| Diametrul coșului de amestecat:  | 120 mm           |
| Lungimea telului de amestecare:  | 600 mm           |
| Weight:                          | 3,7 kg           |



| Nu.   | specificatie      |   |
|-------|-------------------|---|
| 35300 |                   | 1 |
| 35316 | carbon de rezervă | 1 |





**NEW**

**WEST BERG**

**AMESTECĂTOR MATERIALE DE CONSTRUCȚIE, 1600 W**

|                                  |                    |
|----------------------------------|--------------------|
| Putere:                          | 1600 W             |
| Tensiune:                        | 230 V / 50 Hz      |
| Number of gears:                 | 2                  |
| Treapta 1 (turatie la ralanti)   | 180 - 400 ot./min. |
| Treapta a 2 (turatie la ralanti) | 300 - 700 ot./min. |
| Protecție la suprasolicitare:    | Da                 |
| Filet tel de mestecare:          | M 14               |
| Diametrul coșului de amestecat:  | 140 mm             |
| Lungimea telului de amestecare:  | 600 mm             |
| Weight:                          | 5,4 kg             |

|              |                   |           |   |
|--------------|-------------------|-----------|---|
| <b>M14</b>   | <b>Zn</b>         | <b>CE</b> |   |
| Nu.          | specificatie      |           |   |
| <b>35305</b> |                   |           | 1 |
| <b>35315</b> | carbon de rezervă |           | 1 |



**NEW**



**FESTA**  
POWER X TOOLS

**APARAT DE CURATAT CU INALTA PRESIUNE**

|                        |               |             |                    |                    |                 |           |                  |               |
|------------------------|---------------|-------------|--------------------|--------------------|-----------------|-----------|------------------|---------------|
| <b>230 V</b><br>~50 Hz | <b>1800 W</b> | <b>IPX5</b> | <b>MAX 7 l/min</b> | <b>MAX 140 bar</b> | <b>MAX 50°C</b> | <b>5m</b> | <b>AUTO STOP</b> | <b>7,8 kg</b> |
|------------------------|---------------|-------------|--------------------|--------------------|-----------------|-----------|------------------|---------------|

|              |              |   |
|--------------|--------------|---|
| Nu.          | specificatie |   |
| <b>45271</b> |              | 1 |



**FESTA**

**APARAT DE CURATAT CU INALTA PRESIUNE**

|                        |               |                    |                    |             |           |                  |
|------------------------|---------------|--------------------|--------------------|-------------|-----------|------------------|
| <b>230 V</b><br>~50 Hz | <b>1500 W</b> | <b>MAX 120 bar</b> | <b>MAX 6 l/min</b> | <b>IPX5</b> | <b>5m</b> | <b>AUTO STOP</b> |
|------------------------|---------------|--------------------|--------------------|-------------|-----------|------------------|

|              |                       |   |
|--------------|-----------------------|---|
| Nu.          | specificatie          |   |
| <b>45270</b> | high pressure cleaner | 1 |

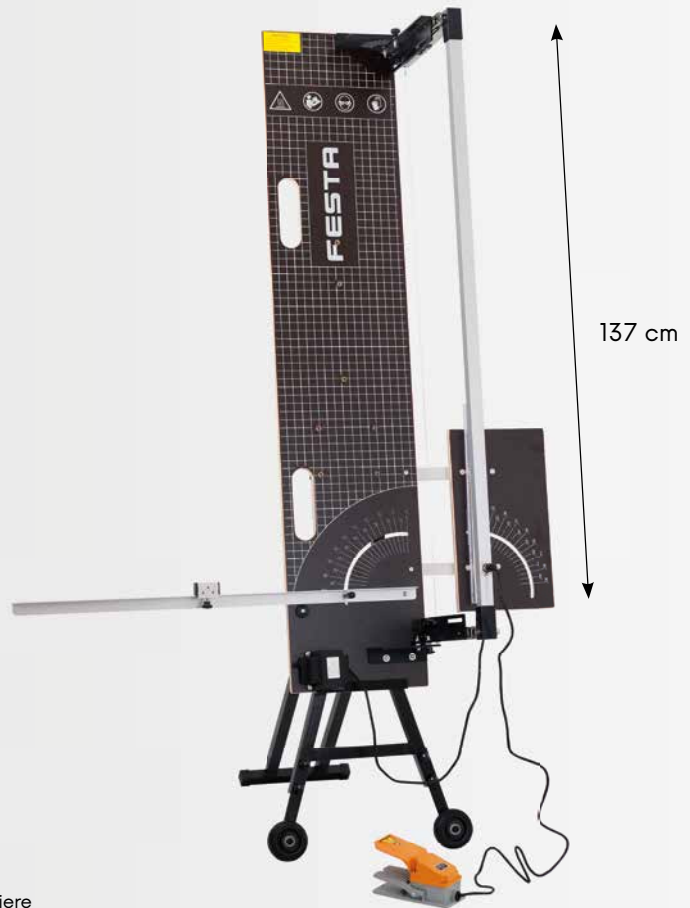
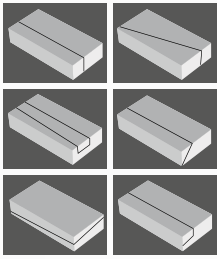

**FESTA**  
POWER X TOOLS

**ȚĂIETOR DE POLISTIREN**

- tensiune | frecvență: 230 V / 50 Hz
- consum de energie: 200 W
- lungimea tăieturii 137 cm
- înălțimea de tăiere 35 cm
- protecție IP44
- unghiul de tăiere 0° - 90°

· echipament: suport, comutator cu picior, suport pentru schelă, 2x sârmă de tăiere Ni-Cr, perie de curățare din alamă, unelte și elemente de fixare, cutie de plastic cu roți



Nu. Specificație

35348

1

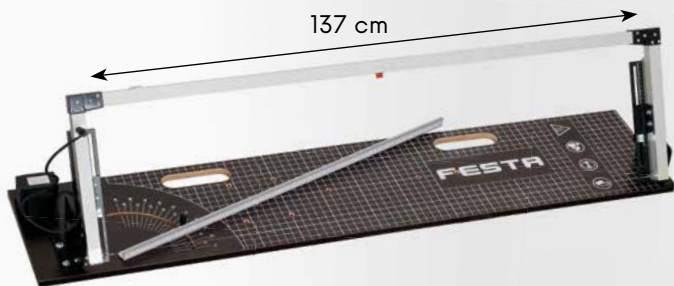
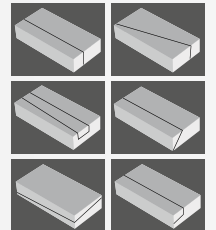
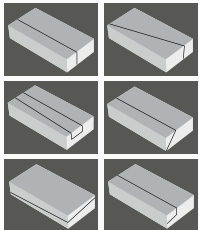

**FESTA**  
POWER X TOOLS

**ȚĂIETOR DE POLISTIREN**

- tensiune | frecvență: 230 V / 50 Hz
- consum de energie: 200 W
- lungimea tăieturii 137 cm
- înălțimea de tăiere 35 cm
- protecție IP44
- unghiul de tăiere 0° - 90°



· echipament: sarma de taiere Ni-Cr, perie de curatare din alama



35345

1

**FESTA**  
POWER X TOOLS

**ȚĂIETOR DE POLISTIREN**

- tensiune | frecvență: 230 V / 50 Hz
- consum de energie: 160 W
- lungimea tăieturii 120 cm
- înălțimea de tăiere 35 cm
- protecție IP44
- unghiul de tăiere 0° - 90°



· echipament: sarma de taiere Ni-Cr, perie de curatare din alama



35330

1



**FESTA**

**TĂIETOR DE POLISTIREN**

- tensiune | frecvență: 230 V / 50 Hz
- consum de energie: 160 W
- lungimea tăieturii: 120 cm
- înălțimea de tăiere: 52 cm
- protecție: IP44
- unghiul de tăiere: 0° - 90°



· echipament: sarma de taiere Ni-Cr, perie de curatare din alama, cheie hexagonala

| Nu.   | specificatie |   |
|-------|--------------|---|
| 35344 |              | 1 |



**FESTA**

**COMUTATOR CU PICIOR PENTRU UN TĂIETOR DE POLISTIREN**

· pentru 35330, 35345, 35348



| Nu.   | Specificatie |   |
|-------|--------------|---|
| 35334 |              | 1 |



**FESTA**

**STAND PENTRU UN TĂIETOR DE POLISTIREN**

· pentru 35330, 35345, 35348



| Nu.   | Specificatie |   |
|-------|--------------|---|
| 35336 |              | 1 |



**FESTA**

**ARC DE SCHIMB PENTRU UN TĂIETOR DE POLISTIREN**

· pentru 35330, 35345, 35348



| Nu.   | Specificatie |   |
|-------|--------------|---|
| 35332 |              | 1 |



**FESTA**

**ADAPTOR DE ALIMENTARE DE REZERVĂ PENTRU UN TĂIETOR DE POLISTIREN**

· pentru 35330, 35345, 35348



- tensiune/frecvență: 230 V / 50Hz
- ieșire: 36 V / 5 A
- putere: 200 W



| Nu.   | Specificatie |   |
|-------|--------------|---|
| 35347 |              | 1 |



**FESTA**

**SUPORT PENTRU SCHELE PENTRU UN TĂIETOR DE POLISTIREN**

· pentru 35330, 35345, 35348



| Nu.   | Specificatie |   |
|-------|--------------|---|
| 35333 |              | 1 |



**FIR DE ÎNCĂLZIRE DE REZERVĂ NI-CR PENTRU CUTTER POLISTIREN**



| Nu.   | Specificatie |   |
|-------|--------------|---|
| 35331 | 117 cm       | 1 |
| 35346 | 137 cm       | 1 |



**Li-ion**  
technology

**FESTA**  
POWER X TOOLS

**TĂIETOR DE POLISTIREN FĂRĂ FIR**

- baterie **36 V, 1,5Ah Li-ion**
- power consumption **180 W**
- temperature **max 350 C°**
- length of knife **20 cm**
- echipament: 2 baterii, încărcător, lamă, perie de alamă, hex



| Nu.   | specificație                             |   |
|-------|--|---|
| 35323 | electric polystyrene cutter              | 1 |
| 35328 | Spare knife for polystyrene cutter 14 cm | 1 |
| 35329 | Spare knife for polystyrene cutter 25 cm | 1 |



**FESTA**  
POWER X TOOLS

**ELECTRIC POLYSTYRENE CUTTER**

- voltage / frequency **230 V/50 Hz**
- power consumption **250 W**
- temperature **50-600 C°**
- length of knife **25 cm**
- length of supply cable **3 m**



· echipament: cleaning brass brush, inbus, dlades 25 and 30 cm,

| Nu.   | specificație                             |   |
|-------|--|---|
| 35326 | electric polystyrene cutter              | 1 |
| 35328 | Spare knife for polystyrene cutter 14 cm | 1 |
| 35329 | Spare knife for polystyrene cutter 25 cm | 1 |



**GUIDE BAR FOR POLYSTYRENE CUTTER 35326**

| Nu.   | specificație        |   |
|-------|---------------------|---|
| 35327 | Guide bar           | 1 |
| 35335 | Spare knife - 30 cm | 1 |

**FESTA**  
POWER X TOOLS

**POLYSTYRENE ELECTRIC CUTTER**



· temperature regulation

| Nu.   | specificație |   |
|-------|--------------|---|
| 35325 | 220 W        | 1 |



**FESTA****WELDING INVERTER TIG/MMA 160 A**

|                                    |  |
|------------------------------------|--|
| Voltage /frequency:                | 230 V / 50 Hz                              |
| Voltage free:                      | 55 V                                       |
| Regulatory range welding currents: | 10 - 160 A                                 |
| Diameter of electrode:             | 1,5 - 4,0 mm                               |
| Working cycle:                     | TIG- 160 A / 60%, MMA - 140 A / 60%        |
| Protection class:                  | IP 21                                      |
| Type of welding:                   | TIG/MMA                                    |
| Dimensions:                        | 405 x 165 x 270 mm                         |
| Technology:                        | Anti-stick, Arc-force, Hot start, Lidf TIG |
| Weight:                            | 6 kg                                       |



| Nu.   | specificație                 |
|-------|------------------------------|
| 70040 | Welding inverter TIG/MMA160A |



1

**FESTA**

LCD display

**FESTA****MASCA SUDURA CU VIZOR SPECIAL**

|                                  |                       |
|----------------------------------|-----------------------|
| dimensiunea câmpului vizual      | 98 x 80 mm            |
| viteza de întunecare a filtrului | 1/25 000 s            |
| diminuarea filtrului             | DIN 5-8 / 9-13        |
| Protecție UV / IR                | DIN 16                |
| clasa optică                     | 1   1   1   2         |
| numărul de senzori               | 4                     |
| alimentare electrică             | napelem + elem CR2450 |
| mod de lucru                     | Sudare, măcinare      |

**CE EN  
379**

| Nu.   | specificație              |
|-------|---------------------------|
| 70064 | activ                     |
| 70066 | sticlă capac de înlocuire |



1

1





**FESTA**

MASCA SUDURA CU VIZOR SPECIAL CARBON



| Nu.   | specificatie |   |
|-------|--------------|---|
| 70063 | activ        | 4 |



MASCA SUDURA CU VIZOR SPECIAL



| Nu.   | specificatie |   |
|-------|--------------|---|
| 70060 | activ        | 4 |



CASCA SUDURA



| Nu.   | specificatie |   |
|-------|--------------|---|
| 70061 |              | 4 |



STICLA OCHELARI SUDURA

2x

| Nu.   | specificatie |    |
|-------|--------------|----|
| 70065 | 113 x 80 mm  | 20 |



OCHELARI SUDURA



| Nu.   | specificatie |   |
|-------|--------------|---|
| 70062 |              | 1 |



ELECTROD RUTILIC

· certificat

| Nu.   | specificatie   | mnoštvi |   |
|-------|----------------|---------|---|
| 70021 | Ø 2,0 x 300 mm | 10 buc  | 1 |
| 70020 | Ø 2,0 x 300 mm | 2,5 kg  | 8 |
| 70026 | Ø 2,5 x 300 mm | 10 buc  | 1 |
| 70025 | Ø 2,5 x 300 mm | 2,5 kg  | 8 |
| 70033 | Ø 3,2 x 350 mm | 10 buc  | 1 |
| 70032 | Ø 3,2 x 350 mm | 5 kg    | 4 |



ELECTROD BASIC

· certificat

| Nu.   | specificatie   | mnoštvi |   |
|-------|----------------|---------|---|
| 70030 | Ø 2,0 x 300 mm | 2,5 kg  | 1 |
| 70031 | Ø 2,0 x 300 mm | 5 kg    | 1 |
| 70035 | Ø 2,5 x 300 mm | 2,5 kg  | 8 |
| 70036 | Ø 2,5 x 300 mm | 10 buc  | 1 |
| 70037 | Ø 3,2 x 350 mm | 5 kg    | 5 |



CIOCAN SUDURA



| Nu.   | specificatie |   |
|-------|--------------|---|
| 19115 | 320 g        | 1 |



CLESTE SUDURA



| Nu.   | specificatie |   |
|-------|--------------|---|
| 70070 | 300 A        | 1 |



CLESTE SUDURA MASA



| Nu.   | specificatie |   |
|-------|--------------|---|
| 70075 | 300 A        | 1 |



**FESTA**

MAGNET UNGHIULAR SUDURA



| Nu.   | specificatie                       | nosnost |    |
|-------|------------------------------------|---------|----|
| 70096 | 150 x 130 x 30 mm · 45°, 90°, 135° | 25 kg   | 10 |

MAGNET UNGHIULAR SUDURA



| Nu.   | specificatie          | nosnost |    |
|-------|-----------------------|---------|----|
| 70090 | 85 x 85 mm · 45°, 90° | 9 kg    | 10 |



MAGNET UNGHIULAR SUDURA



| Nu.   | specificatie                           | nosnost |    |
|-------|--|---------|----|
| 70093 | 95 x 64 mm · 30°, 45°, 60°, 75°, 90°   | 9 kg    | 10 |
| 70094 | 120 x 90 mm · 30°, 45°, 60°, 75°, 90°  | 18 kg   | 10 |
| 70095 | 137 x 110 mm · 30°, 45°, 60°, 75°, 90° | 27 kg   | 10 |

MAGNET UNGHIULAR SUDURA



| Nu.   | specificatie                       | nosnost |    |
|-------|------------------------------------|---------|----|
| 70091 | 95 x 109 x 25 mm · 45°, 90°, 135°  | 13 kg   | 10 |
| 70092 | 130 x 150 x 32 mm · 45°, 90°, 135° | 22 kg   | 5  |



**FESTA**  
POWER X TOOLS

PIPE WELDER

- voltage / frequency 230 V / 50 Hz
- power consumption 750 / 1500 W
- temperature 0-300 C°
- extensions Ø 20,25,32,40,50,63 mm
- weight 1,6 kg



· package included: measuring tape, spirit level, screwdriver, hex key, 6x welding adapter, stand, shelf case



| Nu.   |   |
|-------|---|
| 17182 | 1 |

**FESTA**  
POWER X TOOLS

PIPE WELDER

- voltage / frequency 230 V / 50 Hz
- power consumption 800 / 1000 W
- temperature 0-300 C°
- extensions Ø 16, 20, 25, 32 mm
- weight 1 kg



· package included: hex key, 4x welding adapter, stand, shelf case



| Nu.   |   |
|-------|---|
| 17183 | 1 |

**FESTA**

**COMPRESOR AER 6 L**



|                        |                |
|------------------------|----------------|
| Alimentare:            | 230 V   50Hz   |
| producie:              | 1,2 kW (1,5HP) |
| Capacitate rezervor:   | 6 l            |
| Presiune de lucru:     | 8 Bar          |
| rate                   | 3900 min.      |
| Putere de aspiratie:   | 180 l/min.     |
| Alimentare libera aer: | 116 l/min.     |
| reutate:               | 10 kg          |



| Nu.   | specificatie |   |
|-------|--------------|---|
| 35360 |              | 1 |



**COMPRESOR AER 24 L**



|                          |                            |
|--------------------------|----------------------------|
| producie:                | 1100 W                     |
| Alimentare:              | 230 V   50Hz               |
| Funcionare fara sarcina: | 2850 min-1                 |
| Presiune de lucru:       | 8 bar                      |
| Alimentare libera aer:   | 160 l   min                |
| Tip:                     | Olajmentes   legare gumata |
| Capacitate rezervor:     | 24 L                       |
| reutate:                 | 23 kg                      |



| Nu.   | specificatie |   |
|-------|--------------|---|
| 35361 | 1,1 kW, 24 l | 1 |



**COMPRESOR AER 24 L**



|                          |                 |
|--------------------------|-----------------|
| producie:                | 1500 W          |
| Alimentare:              | 230 V   50Hz    |
| Funcionare fara sarcina: | 2850 min-1      |
| Presiune de lucru:       | 8 bar           |
| Alimentare libera aer:   | 200 l   min     |
| Tip:                     | olajsav   oleic |
| Capacitate rezervor:     | 24 L            |
| reutate:                 | 24 kg           |



| Nu.   | specificatie |   |
|-------|--------------|---|
| 35362 | 1,5 kW, 24 l | 1 |



500 ml



600 ml



1000 ml

**FESTA**

**PISTOL VOPSIT CUPA SUS PLASTIC**

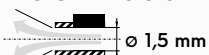

ø 1,5 mm



| Nu.   | specificatie |   |
|-------|--------------|---|
| 48020 | superior     | 1 |

**FESTA**

**PISTOL VOPSIT CUPA SUS PLASTIC**

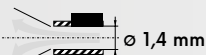

ø 1,4 mm



| Nu.   | specificatie             |   |
|-------|--------------------------|---|
| 48021 | superior                 | 1 |
| 48047 | duza de rezervă ø 1,7 mm | 1 |

**FESTA**

**PISTOL VOPSIT CUPA SUS INOX**



ø 1,4 mm



| Nu.   | specificatie             |   |
|-------|--------------------------|---|
| 48022 | superior                 | 1 |
| 48046 | duza de rezervă ø 1,5 mm | 1 |



**FESTA**

**PISTOL AER SCURT**



| Nu.   | specificație |   |
|-------|--------------|---|
| 48030 | dolní        | 1 |



**PISTOL DE PULVERIZARE PENTRU VOPSELE SI TENCUIELI**

- 4 - 6 Bar
- 5 l
- duză Ø 4; 6; 8 mm

| Nu.   | specificație |   |
|-------|--------------|---|
| 48037 |              | 1 |



**FESTA**

**PISTOL AER SCURT**

- 25 mm
- 90 mm
- 190 mm

| Nu.   | specificație |    |
|-------|--------------|----|
| 48004 |              | 10 |



**FESTA**

**PISTOL AER SCURT**

| Nu.   | specificație |    |
|-------|--------------|----|
| 48005 | scurte       | 25 |



**FESTA**

**PISTOL AER SCURT**

| Nu.   | specificație |    |
|-------|--------------|----|
| 48006 | medium       | 25 |



**FESTA**

**PISTOL AER SCURT**

| Nu.   | specificație |    |
|-------|--------------|----|
| 48007 | lung         | 25 |

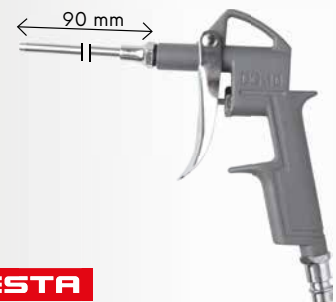

**FESTA**

**PISTOL VOPSEA CU RECIPIENT**

| Nu.   | specificație |   |
|-------|--------------|---|
| 48015 | spodní       | 1 |



**FESTA**

**PISTOL**

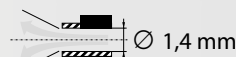

| Nu.   | specificație |   |
|-------|--------------|---|
| 48036 | spodní       | 1 |





30 cm

**FESTA**

**PISTOL AER CU DUZA**

- 0 - 10 bar
- LCD display
- bar, kPa, Psi, kgf/cm<sup>2</sup>

2x AAA

| Nu.   | specificatie |    |
|-------|--------------|----|
| 48011 | 0 - 10 bar   | 10 |



**FESTA**

**PISTOL AER CU DUZA**

| Nu.   | specificatie |   |
|-------|--------------|---|
| 48010 |              | 1 |



**FESTA**

**SET PISTOL**

5x

- 1. pistol vopsea cu recipient
- 2. pistol aer cu duza
- 3. felső tartály pistol vopsea - plastic
- 4. pistol aer scurt
- 5. furtun spiralat conectori inclusi

| Nu.   | specificatie |   |
|-------|--------------|---|
| 48001 |              | 1 |



**FESTA**

**SET PISTOL**

3x

- 1. pistol aer cu duza
- 2. pistol aer scurt
- 3. furtun spiralat conectori inclusi

| Nu.   | specificatie |   |
|-------|--------------|---|
| 48002 |              | 1 |

**NEW**

**ADAPTOARE PENTRU COMPRESOARE**

8x

| Nu.   | specificatie |   |
|-------|--------------|---|
| 48013 |              | 1 |



**FESTA**

**FURTUN SPIRALAT CONECTORI INCLUSI**

| Nu.   | specificatie      |   |
|-------|-------------------|---|
| 48043 | 5 m 8 atm ø 10 mm | 1 |



**FESTA**

**FURTUN SPIRALAT CONECTORI INCLUSI**

| Nu.   | specificatie      |   |
|-------|-------------------|---|
| 48040 | 5 m 8 atm ø 8 mm  | 1 |
| 48041 | 10 m 8 atm ø 8 mm | 1 |
| 48042 | 15 m 8 atm ø 8 mm | 1 |



**FESTA**

**FURTUN SPIRALAT CONECTORI INCLUSI max. 20 Bar**

| Nu.   | specificatie   |   |
|-------|----------------|---|
| 48031 | 5 m ø 9/15 mm  | 1 |
| 48032 | 10 m ø 9/15 mm | 1 |
| 48033 | 15 m ø 9/15 mm | 1 |
| 48034 | 20 m ø 9/15 mm | 1 |

**FESTA**

**FILTRU AER  
SEPARATOR APA**

· max. pressure **10 bar**



| Nu.   | specificație |   |
|-------|--------------|---|
| 48008 | G 1/4'       | 1 |

**FESTA**

**REGULATOR PRESIUNE**

· working pressure **0 - 10 bar**



| Nu.   | specificație |   |
|-------|--------------|---|
| 48009 | G 1/4'       | 1 |

**FESTA**

**DUZE DE REZERVĂ**

· pentru 48021



| Nu.   | specificație  |   |
|-------|---------------|---|
| 48047 | duză Ø 1,7 mm | 1 |

**FESTA**

**DUZE DE REZERVĂ**

· pentru 48022



| Nu.   | specificație  |   |
|-------|---------------|---|
| 48046 | duză Ø 1,5 mm | 1 |

TABEL DIMENSIUNI FILETE DE ȚEAVĂ WHITWORTH

| MĂRIME FILET G ÎN ȚOLI | Ø EXTERIOR MAX. FILETULUI ÎN MM |
|------------------------|---------------------------------|
| 1/8                    | 9,728                           |
| 1/4                    | 13,157                          |
| 3/8                    | 16,662                          |
| 1/2                    | 20,955                          |
| 3/4                    | 26,441                          |
| 1                      | 33,249                          |

**CONECTOR FURTUN**

| Nu.   | specificație      |    |
|-------|-------------------|----|
| 48075 | 1/4' külső   ext. | 10 |
| 48076 | 3/8' külső   ext. | 10 |
| 48077 | 1/2' külső   ext. | 10 |
| 48095 | 1/4' belső   int. | 10 |
| 48096 | 3/8' belső   int. | 10 |
| 48097 | 1/2' belső   int. | 10 |

**ADAPTOR DUBLU**

| Nu.   | specificație          |    |
|-------|-----------------------|----|
| 48050 | 1/4' ext. x 1/4' ext. | 10 |
| 48051 | 1/4' ext. x 3/8' ext. | 10 |

**ADAPTOR**

| Nu.   | specificație          |    |
|-------|-----------------------|----|
| 48054 | 3/8' ext. x 1/4' int. | 10 |
| 48055 | 1/2' ext. x 3/8' int. | 10 |
| 48056 | 3/8' ext. x 1/2' int. | 10 |
| 48057 | 1/4' ext. x 3/8' int. | 10 |

**CONECTOR FURTUN  
FILET EXTERIOR**

| Nu.   | specificație |    |
|-------|--------------|----|
| 48080 | 1/4' ext.    | 10 |
| 48081 | 3/8' ext.    | 10 |
| 48090 | 3/8' int.    | 10 |
| 48091 | 1/4' int.    | 10 |

**RACORD**

| Nu.   | specificație |    |
|-------|--------------|----|
| 48085 | 1/4' - 6 mm  | 10 |
| 48086 | 3/8' - 9 mm  | 10 |
| 48087 | 1/2' - 13 mm | 10 |

**CONECTOR FURTUN**

| Nu.   | specificație |    |
|-------|--------------|----|
| 48070 | 1/4' - 6 mm  | 10 |
| 48071 | 3/8' - 9 mm  | 10 |
| 48072 | 1/2' - 13 mm | 10 |

**ADAPTOR ALAMA  
AER COMPRIMAT**

| Nu.   | specificație        |    |
|-------|---------------------|----|
| 48060 | Ø 6 mm - 1/8' ext.  | 10 |
| 48061 | Ø 6 mm - 1/4' ext.  | 10 |
| 48062 | Ø 6 mm - 3/8' ext.  | 10 |
| 48063 | Ø 9 mm - 1/4' ext.  | 10 |
| 48064 | Ø 9 mm - 3/8' ext.  | 10 |
| 48065 | Ø 13 mm - 1/4' ext. | 10 |
| 48066 | Ø 13 mm - 3/8' ext. | 10 |
| 48067 | Ø 6 mm - 3/8' int.  | 10 |
| 48068 | Ø 9 mm - 3/8' int.  | 10 |
| 48093 | Ø 6 mm - 1/4' int.  | 10 |
| 48094 | Ø 9 mm - 1/4' int.  | 10 |



**FESTA**  
POWER X TOOLS

**PISTOL CU AER FIERBINTE  
CU REGLAJ TEMPERATURĂ**

|           |                            |
|-----------|----------------------------|
| voltaj    | 230V / 50Hz                |
| consumul  | 2000W                      |
| capcsoló  | 0 - I (350°C) - II (550°C) |
| accesorii | prelungiri inox - 4 buc    |



| Nu.   | specificatie |   |
|-------|--------------|---|
| 35320 | 2000 W       | 1 |



**FESTA**  
POWER X TOOLS

**PISTOL CU AER FIERBINTE CU REGLAJ  
TEMPERATURĂ ŞI FLUX AER**

|                         |                                |
|-------------------------|--------------------------------|
| voltaj                  | 230V   50Hz                    |
| consumul                | 2000W                          |
| capcsoló                | 0 - I (50°C) - II (50 - 600°C) |
| flux de aer             | 120 - 500 l/min.               |
| kiegészítők   accesorii | prelungiri inox - 4 buc        |



| Nu.   | specificatie |   |
|-------|--------------|---|
| 35322 | 2000 W       | 1 |

ecran digital

**NEW**



**WEST  
BERG**

**FIER DE LIPIT**

**230V**  
~ 50Hz **175W**



| Nu.   | specificatie           |   |
|-------|------------------------|---|
| 28275 |                        | 1 |
| 28278 | varfuri de lipit 3 buc | 1 |



**NEW**



**WEST  
BERG**

**FIER DE LIPIT**

**230V**  
~ 50Hz **60W**



| Nu.   | specificatie                       |   |
|-------|------------------------------------|---|
| 28280 |                                    | 1 |
| 28282 | Set varf pentru pistol lipit 2 buc | 1 |



**FESTA**  
POWER X TOOLS

**PISTOL DE LIPIT**

· Ø lipici 11,2 mm

**230V**  
~ 50Hz

**80W**



Nu. specificație

**89975**

**20**



**NEW**



**FESTA**  
POWER X TOOLS

**PISTOL DE LIPIT**

· Ø lipici 7,2 mm

**230V**  
~ 50Hz

**12W**



Nu. specificație

**89775**

**1**



**PISTOL DE LIPIT**

· Ø lipici 7,2 mm

**230V**  
~ 50Hz

**15W**



Nu. specificație

**89970**

**25**



**PISTOL DE LIPIT**

· Ø lipici 11,2 mm

**230V**  
~ 50Hz

**60W**



Nu. specificație

**89973**

**20**



**REZERVE BATON PLASTIC, TRANSP.**

| Nu.          | Ø      | lungime |        |     |
|--------------|--------|---------|--------|-----|
| <b>89980</b> | 7,2 mm | 100 mm  | 12 buc | 100 |
| <b>89988</b> | 7,2 mm | 100 mm  | 1 kg   | 25  |



**REZERVE BATON PLASTIC, TRANSP.**

| Nu.          | Ø       | lungime |        |    |
|--------------|---------|---------|--------|----|
| <b>89985</b> | 11,2 mm | 200 mm  | 10 buc | 50 |
| <b>89987</b> | 11,2 mm | 200 mm  | 1 kg   | 25 |



**REZERVE BATON PLASTIC**

| Nu.          | Ø       | lungime |        |     |
|--------------|---------|---------|--------|-----|
| <b>89989</b> | 7,2 mm  | 100 mm  | 12 buc | 100 |
| <b>89990</b> | 11,2 mm | 200 mm  | 10 buc | 50  |



### CORP DE ÎNCĂLZIRE ELECTRIC

|                   |                  |
|-------------------|------------------|
| voltaj            | 230V ~50Hz       |
| putere            | 3300W            |
| Solicitare curent | 14.5A            |
| Setare putere     | 30/1650/3300W    |
| Gama temperatura  | 5-40°C           |
| acoperire         | IP24             |
| dimensiuni        | 27 x 25.5 x 40cm |
| greutate          | 4.8 kg           |



- Încalzire rapida i eficienta a pivnielor, a atelierelor, magazinelor, corturilor pentru party, a serelor etc.
- Nu consuma oxigen
- Exploatare sigura, reglaj continuu putere, termostat spaial, ventilator
- Corp de încălzire din oel inoxidabil
- Posibilitate de utilizare în sezonul de vara pentru ventilatie fara încălzire
- Nivel redus de zgomot
- Executie de calitate, materiale de calitate, structura de oel robusta, manipulare voara i sigura, durata de viaa lunga



| Nu.   | specificatie |
|-------|--------------|
| 35833 | 3,3 kW       |



1

### CORP DE ÎNCĂLZIRE PE GAZ

|                            |           |
|----------------------------|-----------|
| Gaz                        | G30-i3B/P |
| Presiune gaz               | 0.7bar    |
| Tensiune nominala          | 230V 50Hz |
| Putere motor               | 25W       |
| Consum maxim gaz           | 1.11 kg/h |
| Putere de încălzire maxima | 15kW      |
| Volum maxim de aer erbinte | 300m3/h   |

- Încalzire rapida i eficienta în cursul lucrarilor de constructii, în ateliere etc.
- Consuma oxigen!
- Încalzire directa cu circulaie forata – asigurarea rapida a caldurii
- Exploatare sigura, reglaj continuu putere
- Termostat i supapa de sigurana contra supraîncalzirii i scaparii gazului
- Inclusiv accesoriile – regulator i furtun alimentare gaz
- Executie de calitate, materiale de calitate, structura de oel robusta, manipulare voara i sigura, durata de viaa lunga



| Nu.   | specificatie |
|-------|--------------|
| 35845 | 15 kW        |



1

### CORP DE ÎNCĂLZIRE PE GAZ

|                            |           |
|----------------------------|-----------|
| Gaz                        | G30-i3b/p |
| Presiune gaz               | 1.5bar    |
| Tensiune nominala          | 230V 50Hz |
| Putere motor               | 70W       |
| Consum maxim gaz           | 2.2kg/h   |
| Putere de încălzire maxima | 30kW      |
| Volum maxim de aer erbinte | 750m3/h   |

- Încalzire rapida i eficienta în cursul lucrarilor de constructii, în ateliere etc.
- Consuma oxigen!
- Încalzire directa cu circulaie forata – asigurarea rapida a caldurii
- Exploatare sigura, reglaj continuu putere
- Termostat i supapa de sigurana contra supraîncalzirii i scaparii gazului
- Inclusiv accesoriile – regulator i furtun alimentare gaz
- Executie de calitate, materiale de calitate, structura de oel robusta, manipulare voara i sigura, durata de viaa lunga



| Nu.   | specificatie |
|-------|--------------|
| 35850 | 30 kW        |



1



**FESTA**

**LED LAMPĂ**



| Nu.   | specificație |   |
|-------|--------------|---|
| 37611 |              | 1 |



**FESTA**

**LED LAMPĂ**

· max. înălțime 180 cm

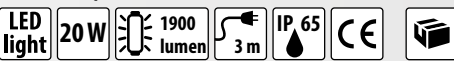

| Nu.   | specificație |   |
|-------|--------------|---|
| 37615 | 20 W         | 1 |
| 37616 | 2 x 20 W     | 1 |



**NEW**



**FESTA**  
INDUSTRY

**CABLU PRELUNGITOR CU TROLIU**

- rubber - IP44
- H07RN-F3G - 2,5mm<sup>2</sup>
- Prevăzut cu siguranță termică
- 16 A max. / 3680 W max.
- 4 prize

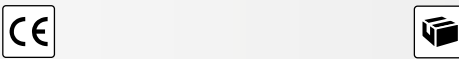

| Nu.   | specificație                      |   |
|-------|-----------------------------------|---|
| 37740 | lungime 25 m, 2,5 mm <sup>2</sup> | 2 |
| 37741 | lungime 50 m, 2,5 mm <sup>2</sup> | 2 |

**NEW**



**FESTA**  
INDUSTRY

**CABLU PRELUNGITOR CU TROLIU**

- rubber - IP44
- H05RR-F3G - 1,5mm<sup>2</sup>
- Prevăzut cu siguranță termică
- 16 A max. / 3680 W max.
- 4 prize

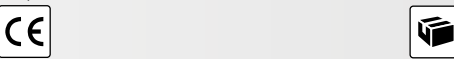

| Nu.   | specificație                      |   |
|-------|-----------------------------------|---|
| 37750 | lungime 25 m, 1,5 mm <sup>2</sup> | 2 |
| 37751 | lungime 50 m, 1,5 mm <sup>2</sup> | 2 |



**FESTA**

**CABLU PRELUNGITOR CU TROLIU**

- IP20
- H05VV - F 3G 1,5mm<sup>2</sup>, -
- Prevăzut cu siguranță termică
- Putere în stare înfășurată: 1000 W max.
- Putere în stare desfășurată : 3000 W max.
- 4 prize



| Nu.   | specificație                      |   |
|-------|-----------------------------------|---|
| 37760 | lungime 25 m, 1,5 mm <sup>2</sup> | 2 |
| 37761 | lungime 50 m, 1,5 mm <sup>2</sup> | 2 |

**FESTA**  
INDUSTRY

**CABLU PRELUNGITOR**

- rubber - IP44
- H07RN-F3G - 1,5mm<sup>2</sup>
- 16 A max. / 3680 W max.



| Nu.   | specificație                      |   |
|-------|-----------------------------------|---|
| 37744 | lungime 5 m, 1,5 mm <sup>2</sup>  | 8 |
| 37745 | lungime 10 m, 1,5 mm <sup>2</sup> | 4 |
| 37746 | lungime 20 m, 1,5 mm <sup>2</sup> | 8 |
| 37747 | lungime 30 m, 1,5 mm <sup>2</sup> | 8 |

**NEW**

**FESTA**

**CABLU PRELUNGITOR**

- IP20
- H05VV-F3G - 1,5mm<sup>2</sup>
- 16 A max. / 3680 W max.



| Nu.   | specificație                                 |   |
|-------|--|---|
| 37730 | lungime 10 m, 1,5 mm <sup>2</sup>            | 8 |
| 37731 | lungime 20 m, 1,5 mm <sup>2</sup>            | 4 |
| 37732 | <b>NEW</b> lungime 30 m, 1,5 mm <sup>2</sup> | 8 |
| 37733 | <b>NEW</b> lungime 40 m, 1,5 mm <sup>2</sup> | 4 |





56

BURGHIE HSS



63

BURGHIE LEMN ȘI  
FREZE LEMN

67

BURGHIE PENTRU ZIDĂRIE,  
DALTA

71

CAROTA DIAMANTATA



74

DISC DIAMANTAT



76

DISC DEBITARE ȘI POLIZARE



80

PERIE CONICA

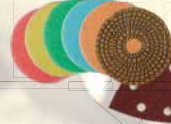

82

DISC ABRAZIV LAMELAT PE  
COADA

86

LAMA PROFESIONALE DE  
FERASTRAU



UNELTE DE TAIAT  
ȘI SLEFUIT

54 - 93



**FESTA**

## BURGHIE HSS-COBALT 5%

Co 5%, W 6%  
Mo 5%, Cr 4%, V 4%**HSS****DIN**  
**338****135°**

INOX

**1400**  
MPa

| Nu.   | specificație |   | Nu.   | specificație |   | Nu.   | specificație |   |
|-------|--------------|---|-------|--------------|---|-------|--------------|---|
| 22510 | Ø 1,00 mm    | 1 | 22548 | Ø 4,80 mm    | 1 | 22590 | Ø 9,00 mm    | 1 |
| 22515 | Ø 1,50 mm    | 1 | 22550 | Ø 5,00 mm    | 1 | 22595 | Ø 9,50 mm    | 1 |
| 22520 | Ø 2,00 mm    | 1 | 22555 | Ø 5,50 mm    | 1 | 22600 | Ø 10,00 mm   | 1 |
| 22525 | Ø 2,50 mm    | 1 | 22560 | Ø 6,00 mm    | 1 | 22602 | Ø 10,20 mm   | 1 |
| 22530 | Ø 3,00 mm    | 1 | 22565 | Ø 6,50 mm    | 1 | 22605 | Ø 10,50 mm   | 1 |
| 22532 | Ø 3,20 mm    | 1 | 22568 | Ø 6,80 mm    | 1 | 22610 | Ø 11,00 mm   | 1 |
| 22535 | Ø 3,50 mm    | 1 | 22570 | Ø 7,00 mm    | 1 | 22615 | Ø 11,50 mm   | 1 |
| 22540 | Ø 4,00 mm    | 1 | 22575 | Ø 7,50 mm    | 1 | 22620 | Ø 12,00 mm   | 1 |
| 22542 | Ø 4,20 mm    | 1 | 22580 | Ø 8,00 mm    | 1 | 22625 | Ø 12,50 mm   | 1 |
| 22545 | Ø 4,50 mm    | 1 | 22585 | Ø 8,50 mm    | 1 | 22630 | Ø 13,00 mm   | 1 |

**FESTA**

## BURGHIE HSS-G W9

W 9%, Mo 3%  
Cr 4%, V 1%**HSS****DIN**  
**338**

INOX

**1100**  
MPa

MOQ



| Nu.   | specificație |    | Nu.   | specificație |   | Nu.   | specificație |   | Nu.   | specificație   |   |
|-------|--------------|----|-------|--------------|---|-------|--------------|---|-------|----------------|---|
| 19530 | Ø 1,00 mm    | 10 | 19579 | Ø 5,90 mm    | 5 | 19612 | Ø 9,20 mm    | 5 | 19639 | Ø 11,90 mm     | 3 |
| 19535 | Ø 1,50 mm    | 10 | 19580 | Ø 6,00 mm    | 5 | 19613 | Ø 9,30 mm    | 5 | 19640 | Ø 12,00 mm     | 3 |
| 19536 | Ø 1,60 mm    | 10 | 19585 | Ø 6,50 mm    | 5 | 19614 | Ø 9,40 mm    | 5 | 19641 | Ø 12,10 mm     | 3 |
| 19537 | Ø 1,70 mm    | 10 | 19586 | Ø 6,60 mm    | 5 | 19615 | Ø 9,50 mm    | 3 | 19642 | Ø 12,20 mm     | 3 |
| 19538 | Ø 1,80 mm    | 10 | 19587 | Ø 6,70 mm    | 5 | 19616 | Ø 9,60 mm    | 3 | 19643 | Ø 12,30 mm     | 3 |
| 19539 | Ø 1,90 mm    | 10 | 19588 | Ø 6,80 mm    | 5 | 19617 | Ø 9,70 mm    | 3 | 19644 | Ø 12,40 mm     | 3 |
| 19540 | Ø 2,00 mm    | 10 | 19589 | Ø 6,90 mm    | 5 | 19618 | Ø 9,80 mm    | 3 | 19645 | Ø 12,50 mm     | 3 |
| 19543 | Ø 2,30 mm    | 10 | 19590 | Ø 7,00 mm    | 5 | 19619 | Ø 9,90 mm    | 3 | 19646 | Ø 12,60 mm     | 1 |
| 19544 | Ø 2,40 mm    | 10 | 19591 | Ø 7,10 mm    | 5 | 19620 | Ø 10,00 mm   | 3 | 19647 | Ø 12,70 mm     | 1 |
| 19545 | Ø 2,50 mm    | 10 | 19593 | Ø 7,30 mm    | 5 | 19621 | Ø 10,10 mm   | 3 | 19648 | Ø 12,80 mm     | 1 |
| 19550 | Ø 3,00 mm    | 10 | 19594 | Ø 7,40 mm    | 5 | 19622 | Ø 10,20 mm   | 3 | 19649 | Ø 12,90 mm     | 1 |
| 19552 | Ø 3,20 mm    | 10 | 19595 | Ø 7,50 mm    | 5 | 19623 | Ø 10,30 mm   | 3 | 19650 | Ø 13,00 mm     | 1 |
| 19554 | Ø 3,40 mm    | 10 | 19596 | Ø 7,60 mm    | 5 | 19624 | Ø 10,40 mm   | 3 | 19651 | Ø 13,20 mm R13 | 1 |
| 19555 | Ø 3,50 mm    | 10 | 19597 | Ø 7,70 mm    | 5 | 19625 | Ø 10,50 mm   | 3 | 19652 | Ø 13,50 mm R13 | 1 |
| 19557 | Ø 3,70 mm    | 10 | 19598 | Ø 7,80 mm    | 5 | 19626 | Ø 10,60 mm   | 3 | 19653 | Ø 14,00 mm R13 | 1 |
| 19559 | Ø 3,90 mm    | 10 | 19599 | Ø 7,90 mm    | 5 | 19627 | Ø 10,70 mm   | 3 | 19654 | Ø 14,50 mm R13 | 1 |
| 19560 | Ø 4,00 mm    | 10 | 19600 | Ø 8,00 mm    | 5 | 19628 | Ø 10,80 mm   | 3 | 19655 | Ø 15,00 mm R13 | 1 |
| 19562 | Ø 4,20 mm    | 10 | 19601 | Ø 8,10 mm    | 5 | 19629 | Ø 10,90 mm   | 3 | 19656 | Ø 15,50 mm R13 | 1 |
| 19564 | Ø 4,40 mm    | 10 | 19603 | Ø 8,30 mm    | 5 | 19630 | Ø 11,00 mm   | 3 | 19657 | Ø 16,00 mm R13 | 1 |
| 19565 | Ø 4,50 mm    | 10 | 19604 | Ø 8,40 mm    | 5 | 19631 | Ø 11,10 mm   | 3 | 19658 | Ø 16,50 mm R13 | 1 |
| 19567 | Ø 4,70 mm    | 10 | 19605 | Ø 8,50 mm    | 5 | 19632 | Ø 11,20 mm   | 3 | 19659 | Ø 17,00 mm R13 | 1 |
| 19568 | Ø 4,80 mm    | 10 | 19606 | Ø 8,60 mm    | 5 | 19633 | Ø 11,30 mm   | 3 | 19660 | Ø 17,50 mm R13 | 1 |
| 19570 | Ø 5,00 mm    | 5  | 19607 | Ø 8,70 mm    | 5 | 19634 | Ø 11,40 mm   | 3 | 19661 | Ø 18,00 mm R13 | 1 |
| 19574 | Ø 5,40 mm    | 5  | 19608 | Ø 8,80 mm    | 5 | 19635 | Ø 11,50 mm   | 3 | 19662 | Ø 18,50 mm R13 | 1 |
| 19575 | Ø 5,50 mm    | 5  | 19609 | Ø 8,90 mm    | 5 | 19636 | Ø 11,60 mm   | 3 | 19663 | Ø 19,00 mm R13 | 1 |
| 19576 | Ø 5,60 mm    | 5  | 19610 | Ø 9,00 mm    | 5 | 19637 | Ø 11,70 mm   | 3 | 19664 | Ø 19,50 mm R13 | 1 |
| 19577 | Ø 5,70 mm    | 5  | 19611 | Ø 9,10 mm    | 5 | 19638 | Ø 11,80 mm   | 3 | 19665 | Ø 20,00 mm R13 | 1 |
| 19578 | Ø 5,80 mm    | 5  |       |              |   |       |              |   |       |                |   |

**FESTA**CUTIE PREZENTARE  
HSS-G W9W 9%, Mo 3%  
Cr 4%, V 1%**HSS****DIN**  
**338**

INOX

**1100**  
MPa

| Nu.   | specificație |   |
|-------|--------------|---|
| 19669 |              | 1 |
| 90191 | fara burghie | 1 |



| Nu.   | continutul setului | Nu.   | continutul setului |
|-------|--------------------|-------|--------------------|
| 19530 | Ø 1,00 mm 20x      | 19585 | Ø 6,50 mm 15x      |
| 19535 | Ø 1,50 mm 20x      | 19590 | Ø 7,00 mm 15x      |
| 19540 | Ø 2,00 mm 20x      | 19595 | Ø 7,50 mm 15x      |
| 19545 | Ø 2,50 mm 20x      | 19600 | Ø 8,00 mm 15x      |
| 19550 | Ø 3,00 mm 20x      | 19605 | Ø 8,50 mm 15x      |
| 19552 | Ø 3,20 mm 20x      | 19610 | Ø 9,00 mm 15x      |
| 19555 | Ø 3,50 mm 20x      | 19615 | Ø 9,50 mm 15x      |
| 19558 | Ø 3,80 mm 20x      | 19620 | Ø 10,00 mm 15x     |
| 19560 | Ø 4,00 mm 30x      | 19625 | Ø 10,50 mm 6x      |
| 19562 | Ø 4,20 mm 20x      | 19630 | Ø 11,00 mm 6x      |
| 19565 | Ø 4,50 mm 20x      | 19635 | Ø 11,50 mm 6x      |
| 19568 | Ø 4,80 mm 20x      | 19640 | Ø 12,00 mm 6x      |
| 19570 | Ø 5,00 mm 15x      | 19645 | Ø 12,50 mm 6x      |
| 19575 | Ø 5,50 mm 15x      | 19650 | Ø 13,00 mm 6x      |
| 19580 | Ø 6,00 mm 30x      |       |                    |

## FESTA

### BURGHIE HSS 4241

W 4%, Mo 3%  
Cr 4%, V 1%

HSS

DIN  
338

ALU 900 MPa



MOQ

| Nu.   | specificație |    | Nu.   | specificație |    | Nu.   | specificație |    | Nu.   | specificație  |   |
|-------|--------------|----|-------|--------------|----|-------|--------------|----|-------|---------------|---|
| 19670 | Ø 0,6 mm     | 10 | 19703 | Ø 4,0 mm     | 10 | 19736 | Ø 7,3 mm     | 10 | 19769 | Ø 10,6 mm     | 5 |
| 19671 | Ø 0,8 mm     | 10 | 19704 | Ø 4,1 mm     | 10 | 19737 | Ø 7,4 mm     | 10 | 19770 | Ø 10,7 mm     | 5 |
| 19672 | Ø 0,9 mm     | 10 | 19705 | Ø 4,2 mm     | 10 | 19738 | Ø 7,5 mm     | 10 | 19771 | Ø 10,8 mm     | 5 |
| 19673 | Ø 1,0 mm     | 10 | 19706 | Ø 4,3 mm     | 10 | 19739 | Ø 7,6 mm     | 10 | 19772 | Ø 11,0 mm     | 5 |
| 19674 | Ø 1,1 mm     | 10 | 19707 | Ø 4,4 mm     | 10 | 19740 | Ø 7,7 mm     | 10 | 19773 | Ø 11,2 mm     | 5 |
| 19675 | Ø 1,2 mm     | 10 | 19708 | Ø 4,5 mm     | 10 | 19741 | Ø 7,8 mm     | 10 | 19774 | Ø 11,3 mm     | 5 |
| 19676 | Ø 1,3 mm     | 10 | 19709 | Ø 4,6 mm     | 10 | 19742 | Ø 7,9 mm     | 10 | 19775 | Ø 11,4 mm     | 5 |
| 19677 | Ø 1,4 mm     | 10 | 19710 | Ø 4,7 mm     | 10 | 19743 | Ø 8,0 mm     | 10 | 19776 | Ø 11,5 mm     | 5 |
| 19678 | Ø 1,5 mm     | 10 | 19711 | Ø 4,8 mm     | 10 | 19744 | Ø 8,1 mm     | 10 | 19777 | Ø 11,6 mm     | 5 |
| 19679 | Ø 1,6 mm     | 10 | 19712 | Ø 4,9 mm     | 10 | 19745 | Ø 8,2 mm     | 10 | 19778 | Ø 11,7 mm     | 5 |
| 19680 | Ø 1,7 mm     | 10 | 19713 | Ø 5,0 mm     | 10 | 19746 | Ø 8,3 mm     | 10 | 19779 | Ø 11,8 mm     | 5 |
| 19681 | Ø 1,8 mm     | 10 | 19714 | Ø 5,1 mm     | 10 | 19747 | Ø 8,4 mm     | 10 | 19780 | Ø 11,9 mm     | 5 |
| 19682 | Ø 1,9 mm     | 10 | 19715 | Ø 5,2 mm     | 10 | 19748 | Ø 8,5 mm     | 10 | 19781 | Ø 12,0 mm     | 5 |
| 19683 | Ø 2,0 mm     | 10 | 19716 | Ø 5,3 mm     | 10 | 19749 | Ø 8,6 mm     | 5  | 19782 | Ø 12,2 mm     | 5 |
| 19684 | Ø 2,1 mm     | 10 | 19717 | Ø 5,4 mm     | 10 | 19750 | Ø 8,7 mm     | 5  | 19783 | Ø 12,5 mm     | 5 |
| 19685 | Ø 2,2 mm     | 10 | 19718 | Ø 5,5 mm     | 10 | 19751 | Ø 8,8 mm     | 5  | 19784 | Ø 12,8 mm     | 5 |
| 19686 | Ø 2,3 mm     | 10 | 19719 | Ø 5,6 mm     | 10 | 19752 | Ø 8,9 mm     | 5  | 19785 | Ø 12,9 mm     | 5 |
| 19687 | Ø 2,4 mm     | 10 | 19720 | Ø 5,7 mm     | 10 | 19753 | Ø 9,0 mm     | 5  | 19786 | Ø 13,0 mm     | 5 |
| 19688 | Ø 2,5 mm     | 10 | 19721 | Ø 5,8 mm     | 10 | 19754 | Ø 9,1 mm     | 5  | 19787 | Ø 13,2 mm R13 | 5 |
| 19689 | Ø 2,6 mm     | 10 | 19722 | Ø 5,9 mm     | 10 | 19755 | Ø 9,2 mm     | 5  | 19788 | Ø 13,5 mm R13 | 5 |
| 19690 | Ø 2,7 mm     | 10 | 19723 | Ø 6,0 mm     | 10 | 19756 | Ø 9,3 mm     | 5  | 19789 | Ø 14,0 mm R13 | 5 |
| 19691 | Ø 2,8 mm     | 10 | 19724 | Ø 6,1 mm     | 10 | 19757 | Ø 9,4 mm     | 5  | 19790 | Ø 14,5 mm R13 | 5 |
| 19692 | Ø 2,9 mm     | 10 | 19725 | Ø 6,2 mm     | 10 | 19758 | Ø 9,5 mm     | 5  | 19791 | Ø 15,0 mm R13 | 5 |
| 19693 | Ø 3,0 mm     | 10 | 19726 | Ø 6,3 mm     | 10 | 19759 | Ø 9,6 mm     | 5  | 19792 | Ø 15,5 mm R13 | 5 |
| 19694 | Ø 3,1 mm     | 10 | 19727 | Ø 6,4 mm     | 10 | 19760 | Ø 9,7 mm     | 5  | 19793 | Ø 16,0 mm R13 | 5 |
| 19695 | Ø 3,2 mm     | 10 | 19728 | Ø 6,5 mm     | 10 | 19761 | Ø 9,8 mm     | 5  | 19794 | Ø 16,5 mm R13 | 5 |
| 19696 | Ø 3,3 mm     | 10 | 19729 | Ø 6,6 mm     | 10 | 19762 | Ø 9,9 mm     | 5  | 19795 | Ø 17,0 mm R13 | 5 |
| 19697 | Ø 3,4 mm     | 10 | 19730 | Ø 6,7 mm     | 10 | 19763 | Ø 10,0 mm    | 5  | 19796 | Ø 17,5 mm R13 | 5 |
| 19698 | Ø 3,5 mm     | 10 | 19731 | Ø 6,8 mm     | 10 | 19764 | Ø 10,1 mm    | 5  | 19797 | Ø 18,0 mm R13 | 5 |
| 19699 | Ø 3,6 mm     | 10 | 19732 | Ø 6,9 mm     | 10 | 19765 | Ø 10,2 mm    | 5  | 19798 | Ø 18,5 mm R13 | 5 |
| 19700 | Ø 3,7 mm     | 10 | 19733 | Ø 7,0 mm     | 10 | 19766 | Ø 10,3 mm    | 5  | 19799 | Ø 19,0 mm R13 | 5 |
| 19701 | Ø 3,8 mm     | 10 | 19734 | Ø 7,1 mm     | 10 | 19767 | Ø 10,4 mm    | 5  | 19800 | Ø 19,5 mm R13 | 5 |
| 19702 | Ø 3,9 mm     | 10 | 19735 | Ø 7,2 mm     | 10 | 19768 | Ø 10,5 mm    | 5  | 19801 | Ø 20,0 mm R13 | 5 |

## FESTA

### CUTIE PREZENTARE HSS

W 4%, Mo 3%  
Cr 4%, V 1%

HSS

DIN  
338

ALU 900 MPa



| Nu.   | specificație |   |
|-------|--------------|---|
| 19802 |              | 1 |
| 90192 | fara burghie | 1 |

| Nu.   | continutul setului | Nu.   | continutul setului |
|-------|--------------------|-------|--------------------|
| 19673 | Ø 1,00 mm 20x      | 19728 | Ø 6,50 mm 20x      |
| 19678 | Ø 1,50 mm 20x      | 19733 | Ø 7,00 mm 10x      |
| 19683 | Ø 2,00 mm 20x      | 19738 | Ø 7,50 mm 10x      |
| 19688 | Ø 2,50 mm 20x      | 19743 | Ø 8,00 mm 10x      |
| 19693 | Ø 3,00 mm 30x      | 19748 | Ø 8,50 mm 10x      |
| 19695 | Ø 3,20 mm 30x      | 19753 | Ø 9,00 mm 10x      |
| 19698 | Ø 3,50 mm 30x      | 19758 | Ø 9,50 mm 10x      |
| 19701 | Ø 3,80 mm 30x      | 19763 | Ø 10,00 mm 10x     |
| 19703 | Ø 4,00 mm 30x      | 19768 | Ø 10,50 mm 10x     |
| 19705 | Ø 4,20 mm 30x      | 19772 | Ø 11,00 mm 10x     |
| 19708 | Ø 4,50 mm 30x      | 19776 | Ø 11,50 mm 10x     |
| 19711 | Ø 4,80 mm 30x      | 19781 | Ø 12,00 mm 10x     |
| 19713 | Ø 5,00 mm 20x      | 19783 | Ø 12,50 mm 10x     |
| 19718 | Ø 5,50 mm 20x      | 19786 | Ø 13,00 mm 5x      |
| 19723 | Ø 6,00 mm 20x      |       |                    |

## FESTA

### BURGHIE HSS

W 4%, Mo 3%  
Cr 4%, V 1%

HSS

DIN  
340

ALU



MOQ

| Nu.   | specificație      |   | Nu.   | specificație      |   | Nu.   | specificație       |   |
|-------|-------------------|---|-------|-------------------|---|-------|--------------------|---|
| 20220 | Ø 2,0 mm x 85 mm  | 1 | 20245 | Ø 4,5 mm x 126 mm | 1 | 20280 | Ø 8,0 mm x 165 mm  | 1 |
| 20225 | Ø 2,5 mm x 95 mm  | 1 | 20250 | Ø 5,0 mm x 132 mm | 1 | 20290 | Ø 9,0 mm x 175 mm  | 1 |
| 20230 | Ø 3,0 mm x 100 mm | 1 | 20255 | Ø 5,5 mm x 139 mm | 1 | 20296 | Ø 10,0 mm x 184 mm | 1 |
| 20235 | Ø 3,5 mm x 110 mm | 1 | 20260 | Ø 6,0 mm x 139 mm | 1 |       |                    |   |
| 20240 | Ø 4,0 mm x 119 mm | 1 | 20270 | Ø 7,0 mm x 156 mm | 1 |       |                    |   |

**HSS BURGHIE TITAN**

\* titanium surface to enhance performance and durability

**TiN** **HSS** **DIN 338**



| Nu.   | specificație |   |
|-------|--------------|---|
| 20400 | Ø 1,0 mm     | 1 |
| 20401 | Ø 1,5 mm     | 1 |
| 20402 | Ø 2,0 mm     | 1 |
| 20403 | Ø 2,5 mm     | 1 |
| 20404 | Ø 3,0 mm     | 1 |
| 20405 | Ø 3,2 mm     | 1 |
| 20406 | Ø 3,5 mm     | 1 |
| 20407 | Ø 3,8 mm     | 1 |
| 20408 | Ø 4,0 mm     | 1 |
| 20409 | Ø 4,2 mm     | 1 |
| 20410 | Ø 4,5 mm     | 1 |

| Nu.   | specificație |   |
|-------|--------------|---|
| 20411 | Ø 4,8 mm     | 1 |
| 20412 | Ø 5,0 mm     | 1 |
| 20413 | Ø 5,5 mm     | 1 |
| 20414 | Ø 6,0 mm     | 1 |
| 20415 | Ø 6,5 mm     | 1 |
| 20416 | Ø 6,8 mm     | 1 |
| 20417 | Ø 7,0 mm     | 1 |
| 20418 | Ø 7,5 mm     | 1 |
| 20419 | Ø 8,0 mm     | 1 |
| 20420 | Ø 8,5 mm     | 1 |
| 20421 | Ø 9,0 mm     | 1 |

| Nu.   | specificație |   |
|-------|--------------|---|
| 20422 | Ø 9,5 mm     | 1 |
| 20423 | Ø 10,0 mm    | 1 |
| 20424 | Ø 10,2 mm    | 1 |
| 20425 | Ø 10,5 mm    | 1 |
| 20426 | Ø 11,0 mm    | 1 |
| 20427 | Ø 11,5 mm    | 1 |
| 20428 | Ø 12,0 mm    | 1 |
| 20429 | Ø 12,5 mm    | 1 |
| 20430 | Ø 13,0 mm    | 1 |

**BURGHIE HSS**

**HSS** **DIN 338**

**ALU**



| Nu.   | specificație  |    |
|-------|---------------|----|
| 19841 | Ø 4,1 mm 5 ks | 10 |
| 19842 | Ø 4,2 mm 5 ks | 10 |
| 19845 | Ø 4,5 mm 5 ks | 10 |
| 19885 | Ø 8,5 mm 1 ks | 10 |
| 19895 | Ø 9,5 mm 1 ks | 10 |



**FESTA**

**SET BURGHIE HSS RECTIFICATE**

W 9%, Mo 3%  
Cr 4%, V 1% **HSS** **DIN 338**

**13x**



| Nu.   | specificație   |    |
|-------|----------------|----|
| 20333 | Ø 1,5 - 6,5 mm | 20 |



**FESTA**

**SET BURGHIE HSS RECTIFICATE**

W 9%, Mo 3%  
Cr 4%, V 1% **HSS** **DIN 338**

**19x**



| Nu.   | specificație    |    |
|-------|-----------------|----|
| 20334 | Ø 1,0 - 10,0 mm | 20 |



**FESTA**

**SET BURGHIE HSS RECTIFICATE**

W 9%, Mo 3%  
Cr 4%, V 1% **HSS** **DIN 338**

**25x**



| Nu.   | specificație    |   |
|-------|-----------------|---|
| 20335 | Ø 1,0 - 13,0 mm | 5 |



**FESTA**

**SET BURGHIE**

W 4%, Mo 3%  
Cr 4%, V 1% **HSS** **DIN 338**

**13x**



| Nu.   | specificație   |   |
|-------|----------------|---|
| 20336 | Ø 1,5 - 6,5 mm | 1 |



**FESTA**

**SET BURGHIE**

W 4%, Mo 3%  
Cr 4%, V 1% **HSS** **DIN 338**

**19x**



| Nu.   | specificație    |    |
|-------|-----------------|----|
| 20337 | Ø 1,0 - 10,0 mm | 20 |



**FESTA**

**SET BURGHIE**

W 4%, Mo 3%  
Cr 4%, V 1% **HSS** **DIN 338**

**25x**



| Nu.   | specificație    |    |
|-------|-----------------|----|
| 20338 | Ø 1,0 - 13,0 mm | 10 |

**FESTA**  
SET BURGHIE

TiN



9x

| Nu.   | specificație |
|-------|--------------|
| 20317 | Ø 5-6-8 mm   |



20



**FESTA**  
SET BURGHIE

1/4" HSS



7x

| Nu.   | specificație           |
|-------|------------------------|
| 20316 | Ø 1,5-2-3-4-5-5,5-6 mm |



20



SET BURGHIE

HSS DIN 338



19x

| Nu.   | specificație    |
|-------|-----------------|
| 20305 | Ø 1,0 - 13,0 mm |

25



SET BURGHIE

HSS DIN 338



25x

| Nu.   | specificație    |
|-------|-----------------|
| 20311 | Ø 1,0 - 13,0 mm |

10



SET BURGHIE

HSS DIN 338



13x

| Nu.   | specificație   |
|-------|----------------|
| 20300 | Ø 1,5 - 6,5 mm |

50



SET BURGHIE

HSS DIN 338



19x

| Nu.   | specificație |
|-------|--------------|
| 20310 | Ø 1 - 13 mm  |

10



**SET BURGHIE**

- burghiu pentru lemn Ø 3 · 4 · 5 · 6 · 8 mm
- burghiu pentru metal Ø 1 · 1,5 · 2 · 2,5 · 3 · 3,5 · 4 · 4,5 · 5 · 5,5 · 6 · 7 · 8 · 10 mm
- burghiu zidarie Ø 4 · 5 · 6 · 8 · 10 mm
- burghiu plat din lemn Ø 16 · 22 · 25 mm
- ferăstrău cu găuri Ø 32 · 38 · 44 · 54 mm
- opritoare de adâncime Ø 6 · 8 · 10 mm

punctator  
calibre de măsurare a diametrului burghiului

- bit 25 mm S 3 · 4 · 4 · 5 · 5 · 6 · 6 · 7
- PH 0 · 0 · 1 · 1 · 2 · 2 · 2 · 3 · 3
- PZ 0 · 0 · 1 · 1 · 2 · 2 · 2 · 3 · 3
- H 2 · 2,5 · 3 · 3,5 · 4 · 5 · 6
- T 10 · 15 · 20 · 25 · 27 · 30 · 40

- bit 50 mm S 4 · 5 · 6 · 6
- PH 1 · 2 · 2 · 3
- PZ 1 · 2 · 2 · 3

adapter  
debavurator  
suport de bițir 4 · 5 · 6 · 7 · 8 · 9 · 10 · 13 mm



**SET BURGHIE**

**HSS** **DIN 338**



**19x**

**100x**

| Nu.   | specifications |   | Nu.   | specificație |    |
|-------|----------------|---|-------|--------------|----|
| 20340 |                | 1 | 20315 | Ø 1 - 10 mm  | 10 |

**SET BURGHIE**

**TiN** **HSS** **DIN 338**



**19x**



**SET BURGHIE**

**HSS** **DIN 338**



**19x**



**ASCUTITOR BURGHIE**

| Nu.   | specificație      |    | Nu.   | specificație         |    |
|-------|-------------------|----|-------|----------------------|----|
| 20320 | Ø 1 - 10 x 0,5 mm | 30 | 20321 | Ø 1 - 10 x 0,5 mm    | 5  |
|       |                   |    | 20380 | pentru Ø 3,5 - 10 mm | 20 |

**FESTA**

**CAROTE BI-METAL**



| Nu.              | specificație |   |
|------------------|--------------|---|
| 24419            | Ø 19 mm      | 1 |
| 24420            | Ø 20 mm      | 1 |
| 24422            | Ø 22 mm      | 1 |
| 24425            | Ø 25 mm      | 1 |
| 24429            | Ø 29 mm      | 1 |
| 24432            | Ø 32 mm      | 1 |
| 24435            | Ø 35 mm      | 1 |
| 24437            | Ø 37 mm      | 1 |
| 24444            | Ø 44 mm      | 1 |
| 24451            | Ø 51 mm      | 1 |
| 24457            | Ø 57 mm      | 1 |
| 24464            | Ø 64 mm      | 1 |
| 24468 <b>NEW</b> | Ø 68 mm      | 1 |
| 24476            | Ø 76 mm      | 1 |
| 24483            | Ø 83 mm      | 1 |



**FESTA**

**SUPORT PENTRU CAROTE HSS BI-METAL**

| Nu.   | specificație             |   |
|-------|--------------------------|---|
| 24410 | pentru carote 14 - 30 mm | 1 |



**FESTA**

**SUPORT PENTRU CAROTE HSS BI-METAL**

| Nu.   | specificație              |   |
|-------|---------------------------|---|
| 24411 | pentru carote 32 - 152 mm | 1 |



**FESTA**

**BURGHIU DE REZERVĂ PENTRU SUPORT PENTRU FERĂSTRĂU**

| Nu.   | Specificație |   |
|-------|--------------|---|
| 24412 | 24410, 24411 | 5 |



**FESTA**

SET CAROTE HSS BI-METAL

HSS



9x

| Nu.   | specificație                |    |
|-------|-----------------------------|----|
| 24750 | Ø 19, 22, 29, 38, 44, 57 mm | 10 |



**FESTA**

SET CAROTE HSS BI-METAL

HSS



13x

| Nu.   | specificație                            |    |
|-------|---|----|
| 24751 | Ø 19, 22, 29, 35, 38, 44, 51, 57, 64 mm | 10 |



**FESTA**

BURGHIU IN TREPTE TITAN

TiN

HSS



| Nu.   | specificație           |    |
|-------|------------------------|----|
| 20489 | Ø 4 - 12 mm 9 steps    | 20 |
| 20490 | Ø 4 - 20 mm 9 steps    | 10 |
| 20491 | Ø 5 - 35 mm 13 steps   | 10 |
| 20492 | Ø 7 - 40,5 mm 13 steps | 5  |



**FESTA**

BURGHIU IN TREPTE TITAN

TiN

HSS



3x

| Nu.   | specificație                |   |
|-------|-----------------------------|---|
| 20495 | Ø 4 - 12, 4 - 20, 4 - 32 mm | 1 |



BURGHIU IN TREPTE

HSS



| Nu.   | specificație           |    |
|-------|------------------------|----|
| 20487 | Ø 4 - 20 mm 9 steps    | 10 |
| 20488 | Ø 5 - 35 mm 13 steps   | 10 |
| 20494 | Ø 4 - 32 mm 15 steps   | 10 |
| 20493 | Ø 7 - 40,5 mm 13 steps | 1  |



BURGHIU IN TREPTE

HSS



3x

| Nu.   | specificație                |   |
|-------|-----------------------------|---|
| 20496 | Ø 4 - 12, 4 - 20, 4 - 32 mm | 1 |





**FESTA**  
EXTRACTOR SURUBURI

- ∅ 4 mm
- ∅ 4,5 mm
- ∅ 6,5 mm
- ∅ 7,5 mm
- ∅ 11 mm
- ∅ 15 mm
- ∅ 19 mm
- ∅ 24 mm

8x

| Nu.   | specificație |   |
|-------|--------------|---|
| 20387 |              | 5 |



CLICHET REGLABIL M3- M8

| Nu.   | specificație |    |
|-------|--------------|----|
| 20397 | M3 - M8      | 10 |



**FESTA**  
EXTRACTOR SURUBURI

- ∅ 4 mm
- ∅ 4,5 mm
- ∅ 6 mm
- ∅ 7,5 mm
- ∅ 11 mm

5x

| Nu.   | specificație |    |
|-------|--------------|----|
| 20386 |              | 10 |



EXTRACTOR SURUBURI

- ∅ 4 mm
- ∅ 4,5 mm
- ∅ 6 mm
- ∅ 7,5 mm
- ∅ 11 mm

5x

| Nu.   | specificație |    |
|-------|--------------|----|
| 20385 |              | 10 |



**FESTA**  
SUPPORT PENTRU FILIERE

DIN 225

| Nu.   | specificație |    |
|-------|--------------|----|
| 20396 | 25 x 9 mm    | 10 |



**FESTA**  
SUPPORT PENTRU TAROZI

DIN 1814

| Nu.   | specificație       |    |
|-------|--------------------|----|
| 20394 | M5 - M20           | 10 |
| 20395 | 1 - 1/2', M3 - M12 | 10 |



**FESTA**  
TAROZI SI FILIERE SET

32x

| Nu.   | specificație               |   |
|-------|----------------------------|---|
| 20391 | M 3, 4, 5, 6, 8, 10, 12 mm | 1 |



**FESTA**  
TAROZI SET

21x

| Nu.   | specificație               |   |
|-------|----------------------------|---|
| 20390 | M 3, 4, 5, 6, 8, 10, 12 mm | 1 |

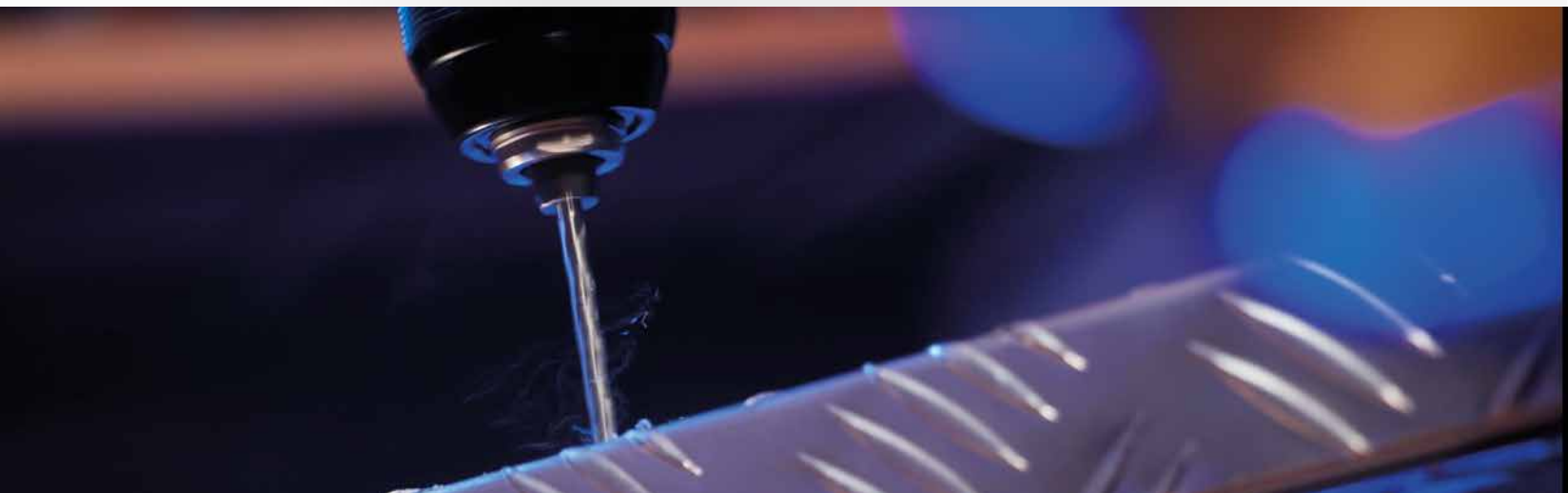



NEW

FESTA

## BURGHIIU FORSTNER

TC



| Nu.   | specificație |   |
|-------|--------------|---|
| 21531 | Ø 15 mm      | 1 |
| 21532 | Ø 20 mm      | 1 |
| 21533 | Ø 25 mm      | 1 |
| 21534 | Ø 30 mm      | 1 |
| 21535 | Ø 35 mm      | 1 |
| 21536 | Ø 40 mm      | 1 |



FESTA

FESTA

## BURGHIE LEMN



| Nu.   | specificație  |   |
|-------|---------------|---|
| 20980 | Ø 6 x 230 mm  | 1 |
| 20957 | Ø 6 x 300 mm  | 1 |
| 20981 | Ø 8 x 230 mm  | 1 |
| 20958 | Ø 8 x 300 mm  | 1 |
| 20982 | Ø 10 x 230 mm | 1 |
| 20896 | Ø 10 x 300 mm | 1 |
| 20913 | Ø 10 x 450 mm | 1 |
| 20983 | Ø 12 x 230 mm | 1 |
| 20897 | Ø 12 x 300 mm | 1 |
| 20915 | Ø 12 x 450 mm | 1 |
| 20920 | Ø 12 x 600 mm | 1 |
| 20898 | Ø 14 x 300 mm | 1 |
| 20916 | Ø 14 x 450 mm | 1 |
| 20921 | Ø 14 x 600 mm | 1 |

| Nu.   | specificație  |   |
|-------|---------------|---|
| 20984 | Ø 16 x 230 mm | 1 |
| 20899 | Ø 16 x 300 mm | 1 |
| 20917 | Ø 16 x 450 mm | 1 |
| 20922 | Ø 16 x 600 mm | 1 |
| 20918 | Ø 18 x 450 mm | 1 |
| 20923 | Ø 18 x 600 mm | 1 |
| 20919 | Ø 20 x 450 mm | 1 |
| 20924 | Ø 20 x 600 mm | 1 |
| 20724 | Ø 22 x 450 mm | 1 |
| 20725 | Ø 24 x 450 mm | 1 |
| 20726 | Ø 26 x 450 mm | 1 |
| 20727 | Ø 28 x 450 mm | 1 |
| 20728 | Ø 30 x 450 mm | 1 |

FESTA

## BURGHIE LEMN SET



5x

| Nu.   | specificație                 |    |
|-------|------------------------------|----|
| 20911 | Ø 8, 10, 12, 14, 16 x 460 mm | 10 |



FESTA

## BURGHIE LEMN SET



6x

| Nu.   | specificație                    |    |
|-------|---------------------------------|----|
| 20912 | Ø 6, 8, 10, 12, 16, 20 x 230 mm | 10 |



## BURGHIE



| Nu.   | specificație  |   |
|-------|---------------|---|
| 20729 | Ø 6 x 400 mm  | 1 |
| 20731 | Ø 8 x 400 mm  | 1 |
| 20736 | Ø 8 x 600 mm  | 1 |
| 20730 | Ø 10 x 400 mm | 1 |
| 20737 | Ø 10 x 600 mm | 1 |



| Nu.   | specificație  |   |
|-------|---------------|---|
| 20732 | Ø 12 x 400 mm | 1 |
| 20738 | Ø 12 x 600 mm | 1 |
| 20733 | Ø 14 x 400 mm | 1 |
| 20739 | Ø 14 x 600 mm | 1 |

| Nu.   | specificație  |   |
|-------|---------------|---|
| 20734 | Ø 16 x 400 mm | 1 |
| 20740 | Ø 16 x 600 mm | 1 |
| 20735 | Ø 18 x 400 mm | 1 |
| 20741 | Ø 18 x 600 mm | 1 |

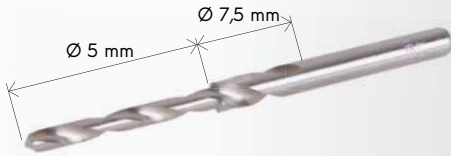

**FESTA**

**BURGHIU COMPLET LA SOL**



| Nu.   | specificație |   |
|-------|--------------|---|
| 20210 | Ø 7,5, 5 mm  | 1 |



**SET BURGHIE LEMN**



| Nu.   | specificație  |   |
|-------|---------------|---|
| 21440 | Ø 4 x 75 mm   | 1 |
| 21441 | Ø 5 x 85 mm   | 1 |
| 21442 | Ø 6 x 90 mm   | 1 |
| 21443 | Ø 7 x 105 mm  | 1 |
| 21444 | Ø 8 x 115 mm  | 1 |
| 21445 | Ø 9 x 120 mm  | 1 |
| 21446 | Ø 10 x 120 mm | 1 |



**BURGHIU FREZARE TITAN HSS**



| Nu.   | specificație |    |
|-------|--------------|----|
| 20460 | Ø 6 mm       | 50 |



**SET BURGHIE LEMN**



| Nu.   | specificație                       |    |
|-------|------------------------------------|----|
| 20910 | 8 buc Ø 3, 4, 5, 6, 7, 8, 9, 10 mm | 10 |
| 20905 | 5 buc Ø 4, 5, 6, 8, 10 mm          | 10 |



**SET FREZE LEMN**



| Nu.   | specificație                   |    |
|-------|--------------------------------|----|
| 21530 | Ø 15, 20, 25, 30, 35 mm Ø 8 mm | 20 |



**SET BURGHIE FREZARE**



| Nu.   | specificație            |    |
|-------|-------------------------|----|
| 20450 | Ø 3, 4, 5, 6, 6.5, 8 mm | 20 |

**SET BURGHIE PLATE**



**6x**

| Nu.   | specificație                |    |
|-------|-----------------------------|----|
| 20901 | Ø 10, 12, 16, 18, 20, 25 mm | 20 |



**SET SFREDELE**

**HOBBY**

**4x**

| Nu.   | specificație    |    |
|-------|-----------------|----|
| 20381 | Ø 2, 3, 4, 5 mm | 20 |





**FESTA**

SET FREZA  
GIPS CARTON + LEMN

- Ø 19 mm
- Ø 22 mm
- Ø 25,5 mm
- Ø 36 mm
- Ø 44 mm
- Ø 51 mm
- Ø 60 mm
- Ø 67 mm
- Ø 76 mm
- Ø 82 mm
- inbus
- 2x cap



12x

| Nu.   | specificație |    |
|-------|--------------|----|
| 24712 | 6 tpi        | 20 |



**FESTA**

SET FREZA  
GIPS CARTON  
+ LEMN

- Ø 64 mm
- Ø 73 mm
- Ø 89 mm
- Ø 102 mm
- Ø 127 mm
- inbus
- cap



8x

| Nu.   | specificație |    |
|-------|--------------|----|
| 24706 | 6 tpi        | 20 |



**FESTA**

· Ø 19 - 127 mm  
CAROTA PENTRU DOZE  
REGLABIL



| Nu.   | Specificație                       |   |
|-------|------------------------------------|---|
| 24415 | Ø 19 - 127 mm<br>max. hlobka 29 mm | 6 |

**FESTA**

SET FREZA  
GIPS CARTON + LEMN



| Nu.   | specificație      |   |
|-------|-------------------|---|
| 24715 | 1' Ø 67 mm 6 tpi  | 5 |
| 24713 | 1' Ø 73 mm 6 tpi  | 5 |
| 24714 | 1' Ø 102 mm 6 tpi | 5 |
| 24720 | 1' Ø 152 mm 6 tpi | 5 |



SET FREZA GIPS CARTON

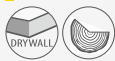

| Nu.   | specificație                       |    |
|-------|------------------------------------|----|
| 24721 | 1' Ø 26, 32, 38, 45, 50, 56, 63 mm | 10 |
| 24722 | 2' Ø 26, 32, 38, 45, 50, 56, 63 mm | 10 |

DISPOZITIV PENTRU  
GAURIT, REGLABIL



| Nu.   | specificație  |   |
|-------|---------------|---|
| 24716 | Ø 30 - 120 mm | 5 |



**FESTA**

FREZE METALICE

M14



| Nu.   | specificație    |   |
|-------|-----------------|---|
| 21807 | Ø 30 mm / 60 mm | 1 |

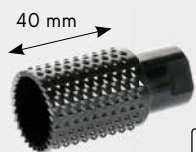

**FESTA**

FREZE METALICE

M14



| Nu.   | specificație     |    |
|-------|------------------|----|
| 21808 | Ø 30 mm / 105 mm | 10 |





FREZE METALICE SET

5x



| Nu.   | specificatie |    |
|-------|--------------|----|
| 21541 |              | 25 |



PIETRE CU TIJA (BIAX) - SET

5x



| Nu.   | specificatie |    |
|-------|--------------|----|
| 21540 | Ø 3 mm, 6 mm | 12 |

ACCESORII PENTRU SLEFUIT

190x



| Nu.   | specificatie |   |
|-------|--------------|---|
| 24755 |              | 5 |

ACCESORII PENTRU SLEFUIT

150x



| Nu.   | specificatie |    |
|-------|--------------|----|
| 24756 |              | 10 |



SET FREZE LEMN



5x



| Nu.   | specificatie |    |
|-------|--------------|----|
| 21450 | Ø 8 mm       | 10 |



SET FREZE LEMN



12x

| Nu.   | specificatie |    |
|-------|--------------|----|
| 21451 | Ø 8 mm       | 10 |



SET FREZE LEMN



24x

| Nu.   | specificatie |   |
|-------|--------------|---|
| 21452 | Ø 8 mm       | 1 |



SET FREZE LEMN



35x

| Nu.   | specificatie |   |
|-------|--------------|---|
| 21453 | Ø 8 mm       | 1 |



SET FREZE LEMN



59x

| Nu.   | specificatie |   |
|-------|--------------|---|
| 21454 | Ø 8 mm       | 1 |

## FESTA

### BURGHIU

DIN 8039



· Burghiu cu două tășuri



| Nu.   | specificație | A mm | B mm |     |
|-------|--------------|------|------|-----|
| 20673 | Ø 3 mm       | 60   | 30   | 100 |
| 20674 | Ø 4 mm       | 75   | 40   | 100 |
| 20675 | Ø 5 mm       | 85   | 50   | 100 |
| 20676 | Ø 6 mm       | 100  | 60   | 100 |
| 20677 | Ø 6 mm       | 200  | 160  | 50  |
| 20685 | Ø 6 mm       | 300  | 260  | 50  |
| 20678 | Ø 8 mm       | 120  | 75   | 50  |
| 20686 | Ø 8 mm       | 200  | 155  | 50  |

| Nu.   | specificație | A mm | B mm |    |
|-------|--------------|------|------|----|
| 20687 | Ø 8 mm       | 300  | 255  | 25 |
| 20688 | Ø 8 mm       | 400  | 340  | 25 |
| 20680 | Ø 10 mm      | 120  | 70   | 50 |
| 20690 | Ø 10 mm      | 200  | 150  | 50 |
| 20691 | Ø 10 mm      | 300  | 250  | 25 |
| 20692 | Ø 10 mm      | 400  | 340  | 25 |
| 20682 | Ø 12 mm      | 150  | 100  | 50 |
| 20694 | Ø 12 mm      | 300  | 250  | 25 |

| Nu.   | specificație    | A mm | B mm |    |
|-------|-----------------|------|------|----|
| 20696 | Ø 12 mm         | 400  | 340  | 25 |
| 20684 | Ø 14 mm         | 150  | 90   | 25 |
|       | reducțe Ø 10 mm |      |      |    |
| 20697 | Ø 14 mm         | 300  | 240  | 5  |
|       | reducțe Ø 10 mm |      |      |    |
| 20698 | Ø 14 mm         | 400  | 340  | 15 |
|       | reducțe Ø 10 mm |      |      |    |

## FESTA

### BURGHIU SDS+

SDS+



· Burghiu cu două tășuri



| Nu.   | specificație | A mm | B mm |  |
|-------|--------------|------|------|--|
| 20855 | Ø 14 mm      | 160  | 75   |  |

| Nu. | specificație | A mm | B mm |    |
|-----|--------------|------|------|----|
|     |              |      |      | 25 |

| Nu. | specificație | A mm | B mm |    |
|-----|--------------|------|------|----|
|     |              |      |      | 25 |

## FESTA

### BURGHIU SDS+

SDS+

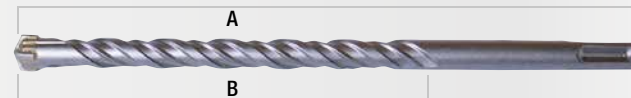

· patru bucăți de găurire cu o creștere a performanței și a duratei de viață



| Nu.   | specificație | A mm | B mm |    |
|-------|--------------|------|------|----|
| 20748 | Ø 6 mm       | 110  | 40   | 50 |
| 20749 | Ø 6 mm       | 160  | 90   | 50 |
| 20750 | Ø 6 mm       | 210  | 140  | 50 |
| 20751 | Ø 6 mm       | 260  | 190  | 50 |
| 20861 | Ø 6,5 mm     | 230  | 160  | 50 |
| 20862 | Ø 6,5 mm     | 300  | 230  | 50 |
| 20752 | Ø 8 mm       | 110  | 40   | 50 |
| 20753 | Ø 8 mm       | 160  | 90   | 50 |
| 20754 | Ø 8 mm       | 210  | 140  | 50 |
| 20755 | Ø 8 mm       | 260  | 190  | 50 |
| 20825 | Ø 8 mm       | 350  | 280  | 50 |
| 20756 | Ø 10 mm      | 160  | 90   | 50 |
| 20757 | Ø 10 mm      | 210  | 140  | 50 |
| 20758 | Ø 10 mm      | 260  | 190  | 50 |
| 20759 | Ø 10 mm      | 350  | 280  | 50 |
| 20760 | Ø 10 mm      | 450  | 380  | 50 |
| 20761 | Ø 10 mm      | 600  | 530  | 50 |
| 20762 | Ø 10 mm      | 1000 | 930  | 50 |
| 20764 | Ø 12 mm      | 160  | 80   | 50 |
| 20765 | Ø 12 mm      | 210  | 130  | 50 |
| 20766 | Ø 12 mm      | 260  | 180  | 50 |
| 20767 | Ø 12 mm      | 350  | 270  | 50 |

| Nu.   | specificație | A mm | B mm |    |
|-------|--------------|------|------|----|
| 20768 | Ø 12 mm      | 460  | 380  | 50 |
| 20769 | Ø 12 mm      | 600  | 520  | 25 |
| 20770 | Ø 12 mm      | 1000 | 920  | 25 |
| 20771 | Ø 14 mm      | 160  | 80   | 25 |
| 20772 | Ø 14 mm      | 260  | 180  | 25 |
| 20773 | Ø 14 mm      | 350  | 270  | 25 |
| 20774 | Ø 14 mm      | 460  | 380  | 25 |
| 20775 | Ø 14 mm      | 600  | 520  | 25 |
| 20776 | Ø 14 mm      | 1000 | 920  | 30 |
| 20777 | Ø 16 mm      | 160  | 80   | 25 |
| 20778 | Ø 16 mm      | 210  | 130  | 25 |
| 20779 | Ø 16 mm      | 260  | 180  | 25 |
| 20780 | Ø 16 mm      | 350  | 270  | 25 |
| 20781 | Ø 16 mm      | 460  | 380  | 25 |
| 20782 | Ø 16 mm      | 600  | 520  | 30 |
| 20783 | Ø 16 mm      | 1000 | 920  | 25 |
| 20784 | Ø 18 mm      | 260  | 180  | 25 |
| 20785 | Ø 18 mm      | 450  | 370  | 25 |
| 20786 | Ø 18 mm      | 600  | 520  | 32 |
| 20787 | Ø 18 mm      | 1000 | 920  | 20 |
| 20788 | Ø 20 mm      | 450  | 370  | 20 |
| 20789 | Ø 20 mm      | 600  | 520  | 20 |

| Nu.   | specificație | A mm | B mm |    |
|-------|--------------|------|------|----|
| 20790 | Ø 20 mm      | 800  | 720  | 25 |
| 20791 | Ø 20 mm      | 1000 | 920  | 10 |
| 20792 | Ø 22 mm      | 450  | 365  | 20 |
| 20793 | Ø 22 mm      | 600  | 520  | 20 |
| 20794 | Ø 22 mm      | 800  | 715  | 20 |
| 20795 | Ø 22 mm      | 1000 | 920  | 10 |
| 20796 | Ø 24 mm      | 450  | 365  | 10 |
| 20797 | Ø 24 mm      | 600  | 520  | 20 |
| 20798 | Ø 24 mm      | 800  | 715  | 10 |
| 20799 | Ø 24 mm      | 1000 | 920  | 10 |
| 20870 | Ø 26 mm      | 450  | 370  | 10 |
| 20871 | Ø 26 mm      | 650  | 570  | 20 |
| 20872 | Ø 26 mm      | 800  | 720  | 10 |
| 20873 | Ø 26 mm      | 1000 | 920  | 10 |
| 20874 | Ø 28 mm      | 450  | 365  | 10 |
| 20875 | Ø 28 mm      | 600  | 565  | 20 |
| 20876 | Ø 28 mm      | 800  | 715  | 10 |
| 20877 | Ø 28 mm      | 1000 | 915  | 10 |
| 20878 | Ø 30 mm      | 450  | 365  | 10 |
| 20879 | Ø 30 mm      | 600  | 565  | 20 |
| 20880 | Ø 30 mm      | 800  | 715  | 10 |
| 20881 | Ø 30 mm      | 1000 | 915  | 10 |

## FESTA

### BURGHIU SDS MAX

SDS MAX

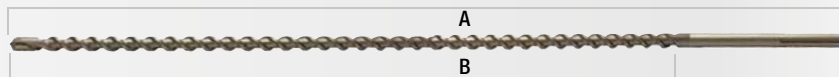

· patru bucăți de găurire cu o creștere a performanței și a duratei de viață



| Nu.   | specificație | A mm | B mm |   |
|-------|--------------|------|------|---|
| 20508 | Ø 16 mm      | 550  | 395  | 5 |
| 20510 | Ø 18 mm      | 550  | 395  | 5 |
| 20520 | Ø 18 mm      | 800  | 650  | 5 |
| 20511 | Ø 20 mm      | 550  | 395  | 5 |
| 20521 | Ø 20 mm      | 800  | 650  | 5 |

| Nu.   | specificație | A mm | B mm |   |
|-------|--------------|------|------|---|
| 20512 | Ø 22 mm      | 550  | 395  | 5 |
| 20522 | Ø 22 mm      | 800  | 650  | 5 |
| 20513 | Ø 24 mm      | 550  | 395  | 5 |
| 20523 | Ø 24 mm      | 800  | 650  | 5 |
| 20514 | Ø 28 mm      | 550  | 395  | 5 |

| Nu.   | specificație | A mm | B mm |   |
|-------|--------------|------|------|---|
| 20524 | Ø 28 mm      | 800  | 650  | 5 |
| 20515 | Ø 30 mm      | 550  | 395  | 5 |
| 20525 | Ø 30 mm      | 800  | 650  | 5 |
| 20516 | Ø 40 mm      | 550  | 395  | 2 |
| 20526 | Ø 40 mm      | 800  | 650  | 1 |

SET BURGHIE SDS+

5x SDS+



| Nu.   | specificatie         |        |    |
|-------|----------------------|--------|----|
| 20890 | Ø 5, 6, 8, 10, 12 mm | 160 mm | 25 |



SET BURGHIE SDS+

6x SDS+



| Nu.   | specificatie                   |                  |    |
|-------|--------------------------------|------------------|----|
| 20891 | Ø 5, 6, 8 mm<br>Ø 8, 10, 12 mm | 110 mm<br>160 mm | 25 |



BURGHIE ZIDARIE

6x DIN 8039



| Nu.   | specificatie         |  |    |
|-------|----------------------|--|----|
| 20895 | Ø 5, 6, 8, 10, 12 mm |  | 25 |



SET BURGHIE



| Nu.   | specificatie      |  |    |
|-------|-------------------|--|----|
| 20805 | 5 buc Ø 4 - 10 mm |  | 10 |
| 20820 | 8 buc Ø 3 - 10 mm |  | 10 |



FESTA

SET BURGHIE, DALTI SPITURI, SDS+

SDS+

4x



| Nu.   | specificatie |   |  |
|-------|--------------|---|--|
| 20954 | 250 mm       | 1 |  |

STATIV DE PROMOVARE

| Nu.   | specificatie |   |  |
|-------|--------------|---|--|
| 20999 |              | 1 |  |



FESTA

SET BURGHIE, DALTI SPITURI, SDS+

- 2 x dalta
- 3 x dalta
- 12 x Ø 5-12 mm

17x SDS+



| Nu.   | specificatie |   |  |
|-------|--------------|---|--|
| 20952 |              | 1 |  |



FESTA

SET BURGHIE, DALTI SPITURI, SDS+

- 1 x dalta 250 mm
- 1 x dalta 22 x 250 mm
- 1 x dalta 20 x 250 mm

- Ø 5 x 110 mm
- Ø 6 x 110 mm
- Ø 8 x 160 mm
- Ø 10 x 160 mm
- Ø 12 x 160 mm
- Ø 14 x 210 mm
- Ø 16 x 210 mm
- Ø 18 x 310 mm
- Ø 20 x 450 mm

12x SDS+



| Nu.   | specificatie |   |  |
|-------|--------------|---|--|
| 20950 |              | 5 |  |



FESTA

DALTA SDS +

SDS+



| Nu.   | specificatie |   |  |
|-------|--------------|---|--|
| 20996 | 250 x 100 mm | 1 |  |



**NEW**



**FESTA**

DALTA SDS +

**SDS+**

| Nu.   | specificație |   |
|-------|--------------|---|
| 20997 | 445 x 130 mm | 1 |

**FESTA**

DALTA 15° SDS +

**SDS+**

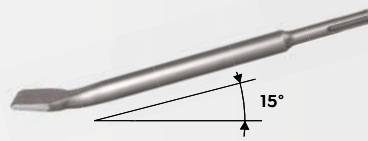

| Nu.   | specificație |   |
|-------|--------------|---|
| 20936 | 40 x 250 mm  | 5 |

**FESTA**

DALTA SDS MAX

**SDS MAX**



| Nu.   | specificație |   |
|-------|--------------|---|
| 20940 | 25 x 280 mm  | 5 |
| 20941 | 40 x 280 mm  | 5 |
| 20942 | 75 x 280 mm  | 5 |
| 20943 | 25 x 400 mm  | 5 |
| 20944 | 40 x 400 mm  | 5 |
| 20945 | 25 x 600 mm  | 5 |
| 20946 | 50 x 600 mm  | 5 |



**FESTA**

DALTA SDS MAX

**SDS MAX**



| Nu.   | specificație  |   |
|-------|---------------|---|
| 20937 | ∅ 18 x 280 mm | 5 |
| 20938 | ∅ 18 x 400 mm | 5 |
| 20939 | ∅ 18 x 600 mm | 2 |



**FESTA**

CAROTA PENTRU DOZE-DINTI TC SDS+

**SDS+**



| Nu.   | specificație |   |
|-------|--------------|---|
| 24719 | ∅ 67 mm      | 1 |
| 24717 | ∅ 73 mm      | 1 |
| 24723 | ∅ 80 mm      | 1 |
| 24718 | ∅ 100 mm     | 1 |
| 24757 | ∅ 115 mm     | 1 |
| 24758 | ∅ 125 mm     | 1 |
| 24759 | ∅ 150 mm     | 1 |



**NEW**

**FESTA**

DALTA SDS MAX

**SDS MAX**

100 mm



| Nu.   | specificație |   |
|-------|--------------|---|
| 20932 | 450 x 100 mm | 1 |

**FESTA**

DALTA SDS +

**SDS+**



| Nu.   | specificație |    |
|-------|--------------|----|
| 20948 | 20 x 250 mm  | 25 |
| 20990 | 20 x 400 mm  | 25 |
| 20949 | 40 x 250 mm  | 25 |
| 20991 | 40 x 400 mm  | 25 |



**FESTA**

DALTA SDS MAX

**SDS+**



| Nu.   | specificație |    |
|-------|--------------|----|
| 20947 | 250 mm       | 25 |
| 20992 | 400 mm       | 25 |



**FESTA**

DALTA SDS +

**SDS+**



| Nu.   | specificație |    |
|-------|--------------|----|
| 20956 | 22 x 250 mm  | 25 |



**FESTA**

LIMITATOR DE PRINDERE PENTRU COROANE DE GĂURI MAX.

**SDS MAX**

| Nu.   | specificație |   |
|-------|--------------|---|
| 24730 | 180 mm       | 1 |



24731

24732

**FESTA**

LIMITATOR DE PRINDERE PENTRU COROANE DE GĂURIT SDS+

**SDS+**

| Nu.   | specificație |   |
|-------|--------------|---|
| 24731 | 300 mm       | 1 |
| 24732 |              | 1 |



**FESTA**

SET COROANE DIAMANTATE



6x



| Nu.   | specificație                            |   |
|-------|---|---|
| 24745 | Ø 33, 53, 67, 73 mm + purtător, burghiu | 1 |

**FESTA**

SET COROANE DIAMANTATE



8x

| Nu.   | specificație                              |   |
|-------|---|---|
| 24747 | Ø 33, 53, 67, 73, 83 mm purtător, burghiu | 1 |



**FESTA**

COROANA DIAMANTATA



| Nu.   | specificație |   |
|-------|--------------|---|
| 24735 | Ø 33 mm      | 1 |
| 24736 | Ø 43 mm      | 1 |
| 24737 | Ø 53 mm      | 1 |
| 24738 | Ø 67 mm      | 1 |
| 24739 | Ø 73 mm      | 1 |
| 24740 | Ø 83 mm      | 1 |
| 24741 | Ø 103 mm     | 1 |



**FESTA**

CAROTA DIAMANTATA

3x



| Nu.   | specificație                 |   |
|-------|------------------------------|---|
| 24746 | Ø 103 mm + purtător, burghiu | 1 |



**FESTA**

BURGHIU



| Nu.   | specificație |    |
|-------|--------------|----|
| 24749 |              | 50 |



**FESTA**

SUPPORT COROANA



| Nu.   | specificație  |    |
|-------|---------------|----|
| 24748 | Ø 33 - 83 mm  | 10 |
| 24743 | Ø 33 - 103 mm | 10 |



**FESTA**

CAROTA - CARBURĂ

· pentru sticlă și ceramică  
· răcire necesară



| Nu.   | specificație |   |
|-------|--------------|---|
| 24770 | Ø 4 mm       | 1 |
| 24771 | Ø 6 mm       | 1 |
| 24772 | Ø 8 mm       | 1 |
| 24773 | Ø 10 mm      | 1 |
| 24774 | Ø 12 mm      | 1 |



COROANA

| Nu.   | specificație |   |
|-------|--------------|---|
| 24726 | Ø 20-95mm    | 1 |



COROANA

| Nu.   | specificație |    |
|-------|--------------|----|
| 24725 | Ø 20-95mm    | 10 |



**FESTA**

PILA CU CARBURI PENTRU PLACI



| Nu.   | specificație |    |
|-------|--------------|----|
| 22200 | 160 mm       | 20 |



**FESTA**

PILA CU CARBURI PENTRU PLACI

· Pentru cărămizile de măcinat



| Nu.   | specificație            |    |
|-------|-------------------------|----|
| 22201 | 200 mm dublă rugozitate | 20 |







## CAROTA DIAMANTATA

- Ø 6 mm
- Ø 8 mm
- Ø 10 mm
- Ø 12 mm
- Ø 20 mm
- Ø 28 mm
- Ø 35 mm
- Ø 45 mm
- Ø 55 mm
- Ø 68 mm

disc taiere / polizare      Ø 125 mm x 2,0 mm    Ø 22,2 mm  
disc taiere                      Ø 125 mm x 1,2 mm    Ø 22,2 mm

coroană de măcinat cu diamante      Ø 0 - 50 mm  
burete diamantat abraziv      90 x 55 mm P60

**13x M14**

- placi ceramice
- marmură
- granit

· Nu. are nevoie de răcire cu apă



| Nu.   | Specificație |   |
|-------|--------------|---|
| 24652 |              | 1 |



## CAROTA DIAMANTATA

**M14**

- placi ceramice
- marmură
- granit

· Nu. are nevoie de răcire cu apă



| Nu.   | Specificație       |   |
|-------|--------------------|---|
| 24620 | Ø 6 mm      M14    | 1 |
| 24621 | Ø 8 mm      M14    | 1 |
| 24622 | Ø 10 mm     M14    | 1 |
| 24623 | Ø 12 mm     M14    | 1 |
| 24624 | Ø 14 mm     M14    | 1 |
| 24627 | Ø 20 mm     M14    | 1 |
| 24630 | Ø 28 mm     M14    | 1 |
| 24633 | Ø 35 mm     M14    | 1 |
| 24636 | Ø 45 mm     M14    | 1 |
| 24638 | Ø 55 mm     M14    | 1 |
| 24640 | Ø 68 mm     M14    | 1 |
| 24642 | NEW Ø 72 mm    M14 | 1 |
| 24643 | Ø 75 mm     M14    | 1 |



## CAROTA DIAMANTATA

- Ø 6 mm
- Ø 8 mm
- Ø 10 mm
- Ø 20 mm
- Ø 35 mm
- Ø 45 mm
- Ø 55 mm
- Ø 68 mm

**8x M14**

- placi ceramice
- marmură
- granit

· Nu. are nevoie de răcire cu apă



| Nu.   | Specificație |   |
|-------|--------------|---|
| 24651 |              | 1 |



## COROANĂ DE MĂCINAT CU DIAMANTE

**M14**

- placi ceramice
- marmură
- granit

· Nu. are nevoie de răcire cu apă



| Nu.   | Specificație |   |
|-------|--------------|---|
| 24795 | Ø 20 / 50 mm | 1 |
| 24797 | Ø 6 / 50 mm  | 1 |
| 24799 | Ø 10 / 50 mm | 1 |



## COROANĂ DE MĂCINAT CU DIAMANTE

**M14**

- placi ceramice
- marmură
- granit

· Nu. are nevoie de răcire cu apă



| Nu.   | Specificație    |   |
|-------|-----------------|---|
| 24775 | NEW Ø 2 - 35 mm | 1 |
| 24777 | Ø 2 - 75 mm     | 1 |
| 24778 | Ø 2 - 50 mm     | 1 |



· Ø 2 mm - Ø 75 mm



**COROANĂ DE MĂCINAT CU DIAMANTE**

M14

- placi ceramice
- marmură
- granit

· Nu. are nevoie de răcire cu apă

| Nu.   | Specificație |   |
|-------|--------------|---|
| 24779 | Ø 20 - 48 mm | 1 |



**COROANĂ DE MĂCINAT CU DIAMANTE**

M14

- placi ceramice
- marmură
- granit

· Nu. are nevoie de răcire cu apă

| Nu.   | Specificație |   |
|-------|--------------|---|
| 24663 | Ø 50 mm      | 1 |



**NEW**



**CAROTA DIAMANTATA**

M14

- placi ceramice
- marmură
- granit

· Nu. are nevoie de răcire cu apă

| Nu.   | specificație | úchyt |   | Nu.   | specificație | úchyt |   |
|-------|--------------|-------|---|-------|--------------|-------|---|
| 24760 | Ø 6 mm       | M14   | 1 | 24766 | Ø 35 mm      | M14   | 1 |
| 24761 | Ø 8 mm       | M14   | 1 | 24776 | Ø 40 mm      | M14   | 1 |
| 24762 | Ø 10 mm      | M14   | 1 | 24767 | Ø 45 mm      | M14   | 1 |
| 24763 | Ø 12 mm      | M14   | 1 | 24791 | Ø 50 mm      | M14   | 1 |
| 24764 | Ø 14 mm      | M14   | 1 | 24768 | Ø 53 mm      | M14   | 1 |
| 24670 | Ø 16 mm      | M14   | 1 | 24792 | Ø 60 mm      | M14   | 1 |
| 24671 | Ø 18 mm      | M14   | 1 | 24793 | Ø 65 mm      | M14   | 1 |
| 24790 | Ø 20 mm      | M14   | 1 | 24769 | Ø 68 mm      | M14   | 1 |
| 24672 | Ø 22 mm      | M14   | 1 | 24794 | Ø 75 mm      | M14   | 1 |
| 24673 | Ø 25 mm      | M14   | 1 | 24796 | Ø 83 mm      | M14   | 1 |
| 24765 | Ø 28 mm      | M14   | 1 | 24677 | Ø102 mm      | M14   | 1 |
| 24674 | Ø 30 mm      | M14   | 1 | 24676 | Ø 110 mm     | M14   | 1 |
| 24675 | Ø 32 mm      | M14   | 1 | 24678 | Ø125 mm      | M14   | 1 |



**COROANĂ DE MĂCINAT CU DIAMANTE**

M14

- placi ceramice
- marmură
- granit

· Nu. are nevoie de răcire cu apă

| Nu.   | Specificație |   |
|-------|--------------|---|
| 24661 | Ø 50 mm      | 1 |



**NEW**



**CAROTA DIAMANTATA**

7x M14

- placi ceramice
- marmură
- granit

· Nu. are nevoie de răcire cu apă

| Nu.   | Specificație |   |
|-------|--------------|---|
| 24650 |              | 1 |



- Ø 8 mm
- Ø 10 mm
- Ø 14 mm
- Ø 22 mm
- Ø 32 mm
- Ø 40 mm
- Ø 68 mm



**CAROTA DIAMANTATA**

- placi ceramice
- marmură
- granit

| Nu.   | specificație |   |
|-------|--------------|---|
| 24700 | Ø 6 mm       | 1 |
| 24701 | Ø 8 mm       | 1 |
| 24702 | Ø 10 mm      | 1 |
| 24703 | Ø 12 mm      | 1 |
| 24704 | Ø 14 mm      | 1 |
| 24705 | Ø 20 mm      | 1 |



**FESTA**

CEARĂ DE RĂCIRE  
PENTRU FERĂSTRĂU  
CU DIAMANTE



| Nu.   | Specificație |   |
|-------|--------------|---|
| 24710 | 30 ml        | 1 |

**FESTA**

CAROTA  
DIAMANTATA



6x

- placi ceramice
- marmură
- granit

| Nu.   | specificație              |   |
|-------|---------------------------|---|
| 24798 | Ø 6, 8, 10, 12, 14, 20 mm | 1 |



**FESTA**

DISC DIAMANTAT

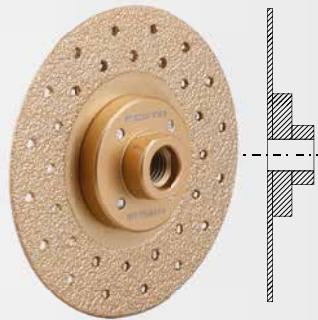

M14

- placi ceramice
- marmură
- granit

Nu. are nevoie de răcire cu apă

| Nu.   | Specificație |   |
|-------|--------------|---|
| 24655 | Ø 115 mm M14 | 1 |

**FESTA**

DISC DE MĂCINAT  
CU DIAMANTE

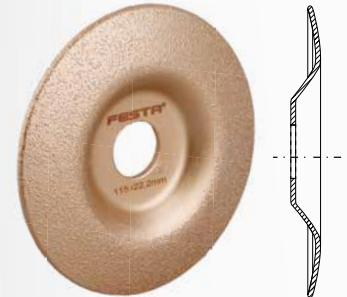

- placi ceramice
- marmură
- granit

Nu. are nevoie de răcire cu apă

| Nu.   | Specificație       |   |
|-------|--------------------|---|
| 24658 | Ø 115 mm Ø 22,2 mm | 1 |

**FESTA**

BURGHIU PENTRU STICLĂ ȘI CERAMICĂ

TiN 1/4"

- placi ceramice
- marmură
- granit

| Nu.   | specificație |    |
|-------|--------------|----|
| 24780 | Ø 4 mm       | 40 |
| 24781 | Ø 5 mm       | 40 |
| 24782 | Ø 6 mm       | 40 |
| 24783 | Ø 8 mm       | 40 |
| 24784 | Ø 10 mm      | 40 |
| 24785 | Ø 12 mm      | 40 |
| 24786 | Ø 14 mm      | 1  |
| 24787 | Ø 16 mm      | 1  |
| 24788 | Ø 18 mm      | 1  |
| 24789 | Ø 20 mm      | 1  |



**FESTA**

BURGHIU PENTRU STICLĂ  
ȘI CERAMICĂ - SET

- Ø 4 mm
- Ø 5 mm
- Ø 6 mm
- Ø 8 mm
- Ø 10 mm

5x

- placi ceramice
- marmură
- granit

Nu. are nevoie de răcire cu apă

| Nu.   | specificație |   |
|-------|--------------|---|
| 24734 |              | 1 |





DISC DIAMANTAT  
TAIERE / POLIZARE

- placi ceramice
- marmura
- granit
- Nu. are nevoie de racire cu apa



| Nu.   | specificatie      |           |   |
|-------|-------------------|-----------|---|
| 21230 | Ø 115 mm x 1,8 mm | Ø 22,2 mm | 1 |
| 21231 | Ø 125 mm x 2,0 mm | Ø 22,2 mm | 1 |



DISC DIAMANTAT TAIERE  
TURBO EXTREME

- placi ceramice
- marmura
- granit
- Nu. are nevoie de racire cu apa

| Nu.   | specificatie      |           |   |
|-------|-------------------|-----------|---|
| 21205 | Ø 125 mm x 2,0 mm | Ø 22,2 mm | 1 |
| 21209 | Ø 230 mm x 2,6 mm | Ø 22,2 mm | 1 |



DISC DIAMANTAT TAIERE

- placi ceramice
- marmura
- granit
- Nu. are nevoie de racire cu apa



| Nu.              | specificatie           |           |   |
|------------------|------------------------|-----------|---|
| 21234 <b>NEW</b> | Ø 115 mm x 1,2 x 8 mm  | Ø 22,2 mm | 1 |
| 21235            | Ø 125 mm x 1,2 x 8 mm  | Ø 22,2 mm | 1 |
| 21238 <b>NEW</b> | Ø 200 mm x 1,6 x 11 mm | Ø 25,4 mm | 1 |



DISC DIAMANTAT ULTRASUBTIRE PROFI

- placi ceramice
- marmura
- granit
- Nu. are nevoie de racire cu apa

| Nu.   | specificatie    |           |   |
|-------|-----------------|-----------|---|
| 21200 | Ø 115 mm 1,4 mm | Ø 22,2 mm | 1 |
| 21201 | Ø 125 mm 1,4 mm | Ø 22,2 mm | 1 |
| 21204 | Ø 200 mm 1,8 mm | Ø 25,4 mm | 1 |
| 21203 | Ø 230 mm 1,8 mm | Ø 22,2 mm | 1 |



**FESTA**

DISC DIAMANTAT



| Nu.   | specificație |           |   |
|-------|--------------|-----------|---|
| 21311 | Ø 115 mm     | Ø 22,2 mm | 1 |
| 21312 | Ø 125 mm     | Ø 22,2 mm | 1 |
| 21315 | Ø 150 mm     | Ø 22,2 mm | 1 |
| 21318 | Ø 180 mm     | Ø 22,2 mm | 1 |
| 21323 | Ø 230 mm     | Ø 22,2 mm | 1 |
| 21324 | Ø 300 mm     | Ø 25,4 mm | 1 |
| 21327 | Ø 350 mm     | Ø 25,4 mm | 1 |
| 21326 | Ø 400 mm     | Ø 25,4 mm | 1 |



**FESTA**

DISC DIAMANTAT TURBO



| Nu.   | specificație |           |   |
|-------|--------------|-----------|---|
| 21411 | Ø 115 mm     | Ø 22,2 mm | 1 |
| 21412 | Ø 125 mm     | Ø 22,2 mm | 1 |
| 21415 | Ø 150 mm     | Ø 22,2 mm | 1 |
| 21418 | Ø 180 mm     | Ø 22,2 mm | 1 |
| 21423 | Ø 230 mm     | Ø 22,2 mm | 1 |
| 21424 | Ø 300 mm     | Ø 25,4 mm | 1 |



**FESTA**

DISC DIAMANTAT



| Nu.   | specificație |           |   |
|-------|--------------|-----------|---|
| 21210 | Ø 110 mm     | Ø 22,2 mm | 1 |
| 21211 | Ø 115 mm     | Ø 22,2 mm | 1 |
| 21212 | Ø 125 mm     | Ø 22,2 mm | 1 |
| 21215 | Ø 150 mm     | Ø 22,2 mm | 1 |
| 21218 | Ø 180 mm     | Ø 22,2 mm | 1 |
| 21219 | Ø 180 mm     | Ø 25,4 mm | 1 |
| 21220 | Ø 200 mm     | Ø 25,4 mm | 1 |
| 21223 | Ø 230 mm     | Ø 22,2 mm | 1 |
| 21224 | Ø 300 mm     | Ø 25,4 mm | 1 |



**FESTA**  
INDUSTRY

DISC DIAMANTAT



| Nu.   | specificație |           |        |
|-------|--------------|-----------|--------|
| 21301 | Ø 125 mm     | Ø 22,2 mm | 1,5 mm |
| 21303 | Ø 230 mm     | Ø 22,2 mm | 1,8 mm |



**FESTA**

DISC DIAMANTAT TURBO



| Nu.   | specificație |         |   |
|-------|--------------|---------|---|
| 21195 | Ø 125 x      | 22,2 mm | 1 |



6 mm



DISC DIAMANTAT



| Nu.   | specificație |           |   |
|-------|--------------|-----------|---|
| 21010 | Ø 110 mm     | Ø 22,2 mm | 1 |
| 21011 | Ø 115 mm     | Ø 22,2 mm | 1 |
| 21012 | Ø 125 mm     | Ø 22,2 mm | 1 |
| 21015 | Ø 150 mm     | Ø 22,2 mm | 1 |
| 21018 | Ø 180 mm     | Ø 22,2 mm | 1 |
| 21023 | Ø 230 mm     | Ø 22,2 mm | 1 |



DISC DIAMANTAT



| Nu.   | specificație |           |   |
|-------|--------------|-----------|---|
| 21110 | Ø 110 mm     | Ø 22,2 mm | 1 |
| 21111 | Ø 115 mm     | Ø 22,2 mm | 1 |
| 21112 | Ø 125 mm     | Ø 22,2 mm | 1 |
| 21115 | Ø 150 mm     | Ø 22,2 mm | 1 |
| 21118 | Ø 180 mm     | Ø 22,2 mm | 1 |
| 21123 | Ø 230 mm     | Ø 22,2 mm | 1 |



DISC DIAMANTAT TURBO



| Nu.   | specificație |           |   |
|-------|--------------|-----------|---|
| 21130 | Ø 110 mm     | Ø 22,2 mm | 1 |
| 21135 | Ø 115 mm     | Ø 22,2 mm | 1 |
| 21140 | Ø 125 mm     | Ø 22,2 mm | 1 |
| 21150 | Ø 150 mm     | Ø 22,2 mm | 1 |
| 21180 | Ø 180 mm     | Ø 22,2 mm | 1 |
| 21190 | Ø 230 mm     | Ø 22,2 mm | 1 |



**FESTA**  
DISC DIAMANTAT



| Nu.   | specificatie |           |   |
|-------|--------------|-----------|---|
| 21435 | Ø 115 mm     | Ø 22,2 mm | 1 |
| 21436 | Ø 125 mm     | Ø 22,2 mm | 1 |
| 21437 | Ø 150 mm     | Ø 22,2 mm | 1 |



**FESTA**  
DISC DIAMANTAT



| Nu.   | specificatie |           |   |
|-------|--------------|-----------|---|
| 21430 | Ø 115 mm     | Ø 22,2 mm | 1 |
| 21431 | Ø 125 mm     | Ø 22,2 mm | 1 |
| 21432 | Ø 150 mm     | Ø 22,2 mm | 1 |



**FESTA**  
DISC DIAMANTAT  
POLIZARE TURBO



| Nu.   | specificatie |           |   |
|-------|--------------|-----------|---|
| 21425 | Ø 100 mm     | Ø 22,2 mm | 1 |
| 21426 | Ø 115 mm     | Ø 22,2 mm | 1 |
| 21427 | Ø 125 mm     | Ø 22,2 mm | 1 |
| 21428 | Ø 150 mm     | Ø 22,2 mm | 1 |



**FESTA**  
INDUSTRY  
DISC TAIERE  
METAL



| Nu.   | specificatie |                    |    |
|-------|--------------|--------------------|----|
| 22258 | Ø 115 mm     | Ø 22,2 mm x 0,8 mm | 25 |
| 22260 | Ø 115 mm     | Ø 22,2 mm x 1 mm   | 25 |
| 22263 | Ø 115 mm     | Ø 22,2 mm x 1,6 mm | 25 |
| 22264 | Ø 115 mm     | Ø 22,2 mm x 2 mm   | 25 |
| 22259 | Ø 125 mm     | Ø 22,2 mm x 0,8 mm | 25 |
| 22266 | Ø 125 mm     | Ø 22,2 mm x 1 mm   | 25 |
| 22269 | Ø 125 mm     | Ø 22,2 mm x 1,6 mm | 25 |
| 22270 | Ø 125 mm     | Ø 22,2 mm x 2 mm   | 25 |
| 22273 | Ø 150 mm     | Ø 22,2 mm x 1,6 mm | 25 |
| 22274 | Ø 150 mm     | Ø 22,2 mm x 2 mm   | 25 |
| 22275 | Ø 150 mm     | Ø 22,2 mm x 2,5 mm | 25 |
| 22277 | Ø 180 mm     | Ø 22,2 mm x 2 mm   | 25 |
| 22280 | Ø 230 mm     | Ø 22,2 mm x 2 mm   | 25 |
| 22281 | Ø 230 mm     | Ø 22,2 mm x 2,5 mm | 25 |



**FESTA**  
INDUSTRY  
DISC TAIERE  
ALUMINIULUI



| Nu.   | specificatie |                  |   |
|-------|--------------|------------------|---|
| 22285 | Ø 115 mm     | Ø 22,2 mm x 1 mm | 1 |
| 22286 | Ø 125 mm     | Ø 22,2 mm x 1 mm | 1 |



**FESTA**  
INDUSTRY  
DISC TAIERE  
PIATRA



| Nu.   | specificatie |                  |   |
|-------|--------------|------------------|---|
| 22294 | Ø 230 mm     | Ø 22,2 mm x 3 mm | 1 |



## FESTA

### DISC TAIERE METAL

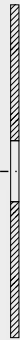

| Nu.   | specificație |                    |      |    |
|-------|--------------|--------------------|------|----|
| 22211 | Ø 115 mm     | Ø 22,2 mm x 1 mm   | INOX | 50 |
| 22212 | Ø 115 mm     | Ø 22,2 mm x 1,2 mm | INOX | 50 |
| 22225 | Ø 125 mm     | Ø 22,2 mm x 1 mm   | INOX | 50 |
| 22217 | Ø 125 mm     | Ø 22,2 mm x 1,2 mm | INOX | 50 |

## FESTA

### DISC TAIERE METAL

10x



| Nu.   | specificație |                    |      |   |
|-------|--------------|--------------------|------|---|
| 22228 | Ø 115 mm     | Ø 22,2 mm x 1 mm   | INOX | 1 |
| 22229 | Ø 125 mm     | Ø 22,2 mm x 1,2 mm | INOX | 1 |

## FESTA

### DISC TAIERE METAL

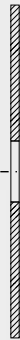

| Nu.   | specificație |                    |  |    |
|-------|--------------|--------------------|--|----|
| 22251 | Ø 115 mm     | Ø 22,2 mm x 1,6 mm |  | 50 |
| 22215 | Ø 115 mm     | Ø 22,2 mm x 2 mm   |  | 50 |
| 22216 | Ø 115 mm     | Ø 22,2 mm x 2,5 mm |  | 50 |
| 22252 | Ø 125 mm     | Ø 22,2 mm x 1,6 mm |  | 25 |
| 22218 | Ø 125 mm     | Ø 22,2 mm x 2,5 mm |  | 25 |
| 22219 | Ø 150 mm     | Ø 22,2 mm x 1,2 mm |  | 25 |
| 22253 | Ø 150 mm     | Ø 22,2 mm x 1,6 mm |  | 50 |
| 22220 | Ø 150 mm     | Ø 22,2 mm x 2,5 mm |  | 50 |
| 22254 | Ø 180 mm     | Ø 22,2 mm x 1,6 mm |  | 50 |
| 22222 | Ø 180 mm     | Ø 22,2 mm x 2,5 mm |  | 25 |
| 22255 | Ø 230 mm     | Ø 22,2 mm x 1,6 mm |  | 25 |
| 22224 | Ø 230 mm     | Ø 22,2 mm x 2,5 mm |  | 25 |

## FESTA

### DISC POLIZARE METAL



| Nu.   | specificație |                    |  |    |
|-------|--------------|--------------------|--|----|
| 22240 | Ø 115 mm     | Ø 22,2 mm x 6,4 mm |  | 25 |
| 22242 | Ø 125 mm     | Ø 22,2 mm x 6,4 mm |  | 25 |
| 22244 | Ø 150 mm     | Ø 22,2 mm x 6,4 mm |  | 25 |
| 22246 | Ø 180 mm     | Ø 22,2 mm x 6,4 mm |  | 25 |
| 22248 | Ø 230 mm     | Ø 22,2 mm x 6,4 mm |  | 25 |

## FESTA

### DISC DIAMANTAT

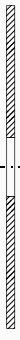

| Nu.   | specificație |           |        |   |
|-------|--------------|-----------|--------|---|
| 21306 | Ø 125 mm     | Ø 22,2 mm | 1,3 mm | 1 |
| 21308 | Ø 230 mm     | Ø 22,2 mm | 1,8 mm | 1 |

## FESTA

### DISC TAIERE PIATRA

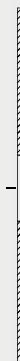

| Nu.   | specificație |                    |  |    |
|-------|--------------|--------------------|--|----|
| 22230 | Ø 115 mm     | Ø 22,2 mm x 2,5 mm |  | 50 |
| 22232 | Ø 125 mm     | Ø 22,2 mm x 2,5 mm |  | 50 |
| 22234 | Ø 150 mm     | Ø 22,2 mm x 2,5 mm |  | 25 |
| 22236 | Ø 180 mm     | Ø 22,2 mm x 2,5 mm |  | 25 |
| 22238 | Ø 230 mm     | Ø 22,2 mm x 2,5 mm |  | 25 |

## FESTA

### DISC CARBID

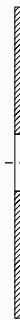

| Nu.   | specificație |           |  |   |
|-------|--------------|-----------|--|---|
| 21192 | Ø 125 mm     | Ø 22,2 mm |  | 1 |
| 21194 | Ø 230 mm     | Ø 22,2 mm |  | 1 |

**FESTA**

DISC SLEFUIRE LEMN



| Nu.   | specificatie |           |  |   |
|-------|--------------|-----------|--|---|
| 21806 | Ø 125 mm     | Ø 22,2 mm |  | 1 |



20 mm



**FESTA**

DISC SLEFUIRE LEMN MEDIU GROSIER



| Nu.   | specificatie |           |      |    |
|-------|--------------|-----------|------|----|
| 21802 | Ø 125 mm     | Ø 22,2 mm | 3 mm | 10 |



**FESTA**

DISC SLEFUIRE LEMN GROSIER



| Nu.   | specificatie |           |      |    |
|-------|--------------|-----------|------|----|
| 21801 | Ø 125 mm     | Ø 22,2 mm | 3 mm | 10 |

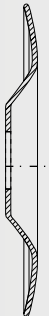

**FESTA**

DISC TAIERE PIATRA / SPATCH



| Nu.   | Specificatie |           |  |   |
|-------|--------------|-----------|--|---|
| 21803 | Ø 125 mm     | Ø 22,2 mm |  | 1 |

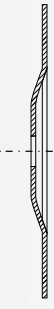

**NEW**

**FESTA**

DISC SLEFUIRE LEMN



| Nu.   | Specificatie |           |  |   |
|-------|--------------|-----------|--|---|
| 21805 | Ø 125 mm     | Ø 22,2 mm |  | 1 |



**FESTA**

DISC PENTRU LEMN CU GĂURI

· pentru slefuirea lemn



| Nu.   | specificatie |           |  |   |
|-------|--------------|-----------|--|---|
| 21800 | Ø 125 mm     | Ø 22,2 mm |  | 1 |

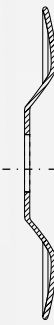

**FESTA**

FREZE METALICE

M14



| Nu.   | specificatie    |  |  |   |
|-------|-----------------|--|--|---|
| 21807 | Ø 30 mm / 60 mm |  |  | 1 |

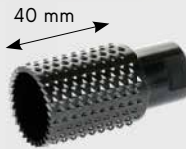

40 mm



**FESTA**

FREZE METALICE

M14



| Nu.   | specificatie     |  |  |    |
|-------|------------------|--|--|----|
| 21808 | Ø 30 mm / 105 mm |  |  | 10 |



65 mm



DISC TAIERE



| Nu.   | Specificatie |           |     |   |
|-------|--------------|-----------|-----|---|
| 21804 | Ø 125 mm     | Ø 22,2 mm | 14T | 1 |





**NEW**

**DISC  
TAIERE**



| Nu.   | Specificație  |           |   |
|-------|---------------|-----------|---|
| 21809 | Ø 125 mm x 4T | Ø 22,2 mm | 1 |

**NEW**

**FESTA**  
**DISC  
LAMELAR  
FRONTAL**



| Nu.   | specificație       | asperity |    |
|-------|--------------------|----------|----|
| 21760 | Ø 125 mm Ø 22,2 mm | P40      | 10 |
| 21761 | Ø 125 mm Ø 22,2 mm | P60      | 10 |
| 21762 | Ø 125 mm Ø 22,2 mm | P80      | 10 |
| 21763 | Ø 125 mm Ø 22,2 mm | P100     | 10 |
| 21764 | Ø 125 mm Ø 22,2 mm | P120     | 10 |

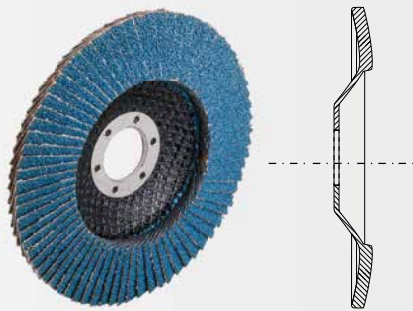

**FESTA**

**DISC LAMELAR FRONTAL**

grinding disc suitable for gringing stainless steel



| Nu.   | specificație       | asperity |   |
|-------|--------------------|----------|---|
| 22140 | Ø 115 mm Ø 22,2 mm | P40      | 5 |
| 22141 | Ø 115 mm Ø 22,2 mm | P60      | 5 |
| 22142 | Ø 115 mm Ø 22,2 mm | P80      | 5 |
| 22143 | Ø 115 mm Ø 22,2 mm | P100     | 5 |
| 22145 | Ø 125 mm Ø 22,2 mm | P40      | 5 |
| 22146 | Ø 125 mm Ø 22,2 mm | P60      | 5 |
| 22147 | Ø 125 mm Ø 22,2 mm | P80      | 5 |
| 22148 | Ø 125 mm Ø 22,2 mm | P100     | 5 |
| 22150 | Ø 150 mm Ø 22,2 mm | P40      | 5 |
| 22151 | Ø 150 mm Ø 22,2 mm | P60      | 5 |
| 22155 | Ø 150 mm Ø 22,2 mm | P80      | 5 |
| 22156 | Ø 150 mm Ø 22,2 mm | P100     | 5 |

**NEW**

**FESTA  
INDUSTRY**

**DISC LAMELAR FRONTAL  
CU DIAMANTE**



- placi ceramice
- marmura
- granit



- Nu. are nevoie de racire cu apa

| Nu.   | specificație |           |        |  |   |
|-------|--------------|-----------|--------|--|---|
| 24647 | Ø 115 mm     | Ø 22,2 mm | ● P60  |  | 1 |
| 24648 | Ø 115 mm     | Ø 22,2 mm | ● P120 |  | 1 |
| 24649 | Ø 115 mm     | Ø 22,2 mm | ● P200 |  | 1 |

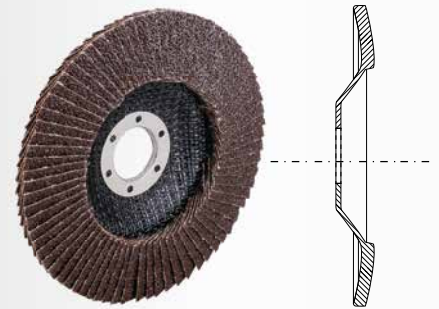

**DISC LAMELAR FRONTAL**



| Nu.   | specificație       | asperity |    |
|-------|--------------------|----------|----|
| 21780 | Ø 115 mm Ø 22,2 mm | P40      | 10 |
| 21781 | Ø 115 mm Ø 22,2 mm | P60      | 10 |
| 21782 | Ø 115 mm Ø 22,2 m  | P80      | 10 |
| 21783 | Ø 115 mm Ø 22,2 mm | P100     | 10 |
| 21784 | Ø 115 mm Ø 22,2 mm | P120     | 10 |
| 21786 | Ø 125 mm Ø 22,2 mm | P40      | 10 |
| 21787 | Ø 125 mm Ø 22,2 mm | P60      | 10 |
| 21788 | Ø 125 mm Ø 22,2 mm | P80      | 10 |
| 21789 | Ø 125 mm Ø 22,2 mm | P100     | 10 |
| 21790 | Ø 125 mm Ø 22,2 mm | P120     | 10 |
| 21792 | Ø 150 mm Ø 22,2 mm | P40      | 10 |
| 21793 | Ø 150 mm Ø 22,2 mm | P60      | 10 |
| 21794 | Ø 150 mm Ø 22,2 mm | P80      | 10 |
| 21795 | Ø 150 mm Ø 22,2 mm | P100     | 10 |
| 21796 | Ø 150 mm Ø 22,2 mm | P120     | 10 |

**DISC NYLON**



| Nu.   | specificație       |   |
|-------|--------------------|---|
| 21798 | Ø 125 mm Ø 22,2 mm | 1 |



# FESTA



20mm

**FESTA**  
PERIE CONICA

· cu acoperire de aramă

| Nu.   | specificație | sărmă |    |
|-------|--------------|-------|----|
| 21900 | Ø 100 mm M14 | s 0,3 | 60 |
| 21902 | Ø 125 mm M14 | s 0,3 | 42 |



10mm

**FESTA**  
PERIE CONICA

· cu acoperire de aramă

| Nu.   | specificație | sărmă |    |
|-------|--------------|-------|----|
| 22001 | Ø 100 mm M14 | s 0,3 | 60 |
| 21901 | Ø 125 mm M14 | s 0,3 | 42 |



**FESTA**  
PERIE CONICA

· alamă

| Nu.   | specificație | sărmă |    |
|-------|--------------|-------|----|
| 21920 | Ø 100 mm M14 | s 0,3 | 60 |



**FESTA**  
PERIE CUPA

· cu acoperire de aramă

| Nu.   | specificație | sărmă |    |
|-------|--------------|-------|----|
| 21903 | Ø 65 mm M14  | s 0,3 | 60 |
| 22002 | Ø 75 mm M14  | s 0,3 | 80 |
| 21904 | Ø 85 mm M14  | s 0,3 | 60 |
| 22003 | Ø 100 mm M14 | s 0,3 | 36 |
| 21905 | Ø 125 mm M14 | s 0,3 | 24 |
| 21906 | Ø 150 mm M14 | s 0,3 | 12 |



**FESTA**  
PERIE CUPA

· alamă

| Nu.   | specificație | sărmă  |    |
|-------|--------------|--------|----|
| 21925 | Ø 75 mm M14  | 0,3 mm | 80 |
| 21926 | Ø 100 mm M14 | 0,3 mm | 36 |



**FESTA**  
PERIE ROTATIVA

· cu acoperire de aramă  
· discuri de reducere

| Nu.   | specificație       | sărmă |    |
|-------|--------------------|-------|----|
| 22007 | Ø 100 mm Ø 20 mm   | s 0,3 | 60 |
| 22008 | Ø 125 mm Ø 20 mm   | s 0,3 | 42 |
| 22009 | Ø 150 mm Ø 32,2 mm | s 0,3 | 32 |
| 22010 | Ø 175 mm Ø 32,2 mm | s 0,3 | 20 |
| 22011 | Ø 200 mm Ø 32,2 mm | s 0,3 | 20 |



**FESTA**  
PERIE CUPA TOROANE

· călit

| Nu.   | specificație | sărmă |    |
|-------|--------------|-------|----|
| 22037 | Ø 65 mm M14  | s 0,5 | 60 |
| 22038 | Ø 80 mm M14  | s 0,5 | 24 |



**FESTA**  
PERIE CUPA TOROANE

· călit

| Nu.   | specificație | sărmă |    |
|-------|--------------|-------|----|
| 22004 | Ø 65 mm M14  | s 0,3 | 60 |
| 22005 | Ø 75 mm M14  | s 0,3 | 24 |
| 22006 | Ø 100 mm M14 | s 0,3 | 24 |
| 21907 | Ø 125 mm M14 | s 0,3 | 24 |
| 21908 | Ø 150 mm M14 | s 0,3 | 12 |



**FESTA**  
PERIE ROTATIVA TOROANE

· călit

| Nu.   | specificație | sărmă | počet copii |    |
|-------|--------------|-------|-------------|----|
| 21911 | Ø 100 mm M14 | s 0,5 | 30          | 60 |
| 21912 | Ø 115 mm M14 | s 0,5 | 32          | 42 |
| 21913 | Ø 125 mm M14 | s 0,5 | 36          | 42 |
| 21914 | Ø 150 mm M14 | s 0,5 | 40          | 32 |

**FESTA**

## PERIE ROTATIVA TOROANE

· călit

**M14**

| Nu.   | specificație | sărmă |    |
|-------|--------------|-------|----|
| 22012 | Ø 100 mm M14 | s 0,5 | 60 |
| 22013 | Ø 115 mm M14 | s 0,5 | 42 |
| 22014 | Ø 125 mm M14 | s 0,5 | 42 |
| 22015 | Ø 150 mm M14 | s 0,5 | 32 |
| 22016 | Ø 178 mm M14 | s 0,5 | 20 |

**FESTA**

## PERIE ROTATIVA TOROANE

· călit

**INOX M14**

| Nu.   | specificație | sărmă |    |
|-------|--------------|-------|----|
| 22039 | Ø 100 mm M14 | s 0,5 | 60 |
| 22040 | Ø 125 mm M14 | s 0,5 | 42 |

**FESTA**

## PERIE CONICA TOROANE

· călit

**M14**

| Nu.   | specificație | sărmă |    |
|-------|--------------|-------|----|
| 22017 | Ø 100 mm M14 | s 0,5 | 60 |
| 21909 | Ø 115 mm M14 | s 0,5 | 42 |
| 21910 | Ø 125 mm M14 | s 0,5 | 42 |



Ø 6 mm

**FESTA**PERIE ROTATIVA TOROANE  
CU TIJA

· călit

| Nu.   | specificație | sărmă |    |
|-------|--------------|-------|----|
| 22023 | Ø 75 mm      | s 0,5 | 10 |



Ø 6 mm

**FESTA**

## PERIE CUPA

· călit

| Nu.   | specificație | sărmă |    |
|-------|--------------|-------|----|
| 22024 | Ø 75 mm      | s 0,5 | 12 |



Ø 6 mm

**FESTA**PERIE CONICA TOROANE  
CU TIJA

· călit

| Nu.   | specificație | sărmă |    |
|-------|--------------|-------|----|
| 22025 | Ø 75 mm      | s 0,5 | 12 |

**NEW****FESTA**PERIE ROTATIVA  
TOROANE

| Nu.   | specificație     | sărmă |   |
|-------|------------------|-------|---|
| 21950 | Ø 200 mm 25,4 mm |       | 1 |



Ø 6 mm

**FESTA**

## PERIE CUPA, TIJA

· cu acoperire de aramă

| Nu.   | specificație | sărmă |    |
|-------|--------------|-------|----|
| 22030 | Ø 65 mm      | s 0,3 | 12 |
| 22031 | Ø 75 mm      | s 0,3 | 12 |



Ø 6 mm

**FESTA**

## PERIE CIRCULARA, TIJA

· cu acoperire de aramă

| Nu.   | specificație | sărmă |    |
|-------|--------------|-------|----|
| 22026 | Ø 50 mm      | s 0,3 | 15 |
| 22027 | Ø 63 mm      | s 0,3 | 15 |
| 22028 | Ø 75 mm      | s 0,3 | 10 |
| 22029 | Ø 100 mm     | s 0,3 | 15 |



Ø 6 mm

**FESTA**

## PERIE PENSULA, TIJA

| Nu.   | specificație | sărmă |    |
|-------|--------------|-------|----|
| 22058 | Ø 12 mm      | s 0,3 | 25 |
| 22059 | Ø 25 mm      | s 0,3 | 25 |



Ø 6 mm

**FESTA**

## PERIE PENSULA, TIJA

· cu acoperire de aramă

| Nu.   | specificație | sărmă |    |
|-------|--------------|-------|----|
| 22018 | Ø 12 mm      | s 0,3 | 15 |
| 22019 | Ø 17 mm      | s 0,3 | 15 |
| 22020 | Ø 25 mm      | s 0,3 | 25 |



Ø 6 mm

**FESTA**

## PERIE PENSULA RASUCITA

· călit

| Nu.   | specificație | sărmă |    |
|-------|--------------|-------|----|
| 22021 | Ø 19 mm      | s 0,5 | 30 |
| 22022 | Ø 22 mm      | s 0,5 | 25 |



**FESTA**

PERIE ROTATIVA NYLON

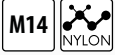

| Nu.   | specificație | sărmă  |   |
|-------|--------------|--------|---|
| 21940 | Ø 75 mm M14  | 1,2 mm | 1 |
| 21941 | Ø 100 mm M14 | 1,2 mm | 1 |



**FESTA**

PERIE ROTATIVA NYLON



| Nu.   | specificație | sărmă  |    |
|-------|--------------|--------|----|
| 21930 | Ø 125 mm M14 | 1,2 mm | 10 |
| 21931 | Ø 150 mm M14 | 1,2 mm | 15 |

Ø 6 mm



**FESTA**

PERIE EVANTAI, TIJA



| Nu.   | specificație | sărmă  |    |
|-------|--------------|--------|----|
| 22032 | Ø 100 mm     | 1,2 mm | 12 |

Ø 6 mm



**FESTA**

PERIE ROTATIVA NYLON



| Nu.   | specificație | sărmă  |   |
|-------|--------------|--------|---|
| 21935 | Ø 50 mm      | 1,2 mm | 1 |
| 21936 | Ø 75 mm      | 1,2 mm | 1 |
| 21937 | Ø 100 mm     | 1,2 mm | 1 |



Ø 6 mm

DISC NYLON



| Nu.   | specificație |   |
|-------|--------------|---|
| 22088 | Ø 65 mm      | 9 |
| 22090 | Ø 100 mm     | 5 |



DISC NYLON



| Nu.   | specificație       |    |
|-------|--------------------|----|
| 22083 | Ø 115 mm Ø 22,2 mm | 10 |
| 22084 | Ø 125 mm Ø 22,2 mm | 10 |
| 22085 | Ø 150 mm Ø 22,2 mm | 10 |



DISC NYLON



| Nu.   | specificație |   |
|-------|--------------|---|
| 22095 | Ø 178 mm     | 1 |

**NEW**

**FESTA**

DISC DE LUSTRUIT  
CU DIAMANTE  
CU VELCRO

- placi ceramice
- sticlă
- marmură
- granit



• suport 22043

| Nu.   | specificație | asperity |    |
|-------|--------------|----------|----|
| 24665 | Ø 100 mm     | ● P60    | 10 |
| 24666 | Ø 100 mm     | ● P120   | 10 |
| 24667 | Ø 100 mm     | ● P200   | 10 |

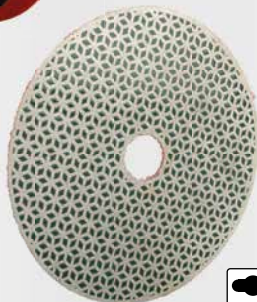

**FESTA**

DISC DE LUSTRUIT  
CU DIAMANTE  
Ø 100 MM,  
CU VELCRO

- placi ceramice
- sticlă
- marmură
- granit



• suport 22043

| Nu.   | asperity |   |
|-------|----------|---|
| 22701 | 50       | 1 |
| 22702 | 100      | 1 |
| 22703 | 200      | 1 |
| 22704 | 400      | 1 |
| 22705 | 800      | 1 |
| 22706 | 1500     | 1 |
| 22707 | 3000     | 1 |



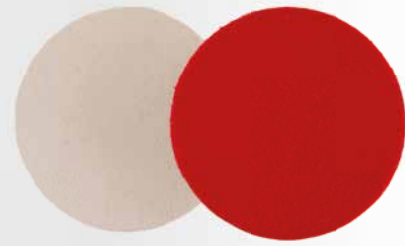

## DISC LUSTRIRE

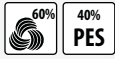

| Nu.   | specificație | specificație |    |
|-------|--------------|--------------|----|
| 22065 | Ø 125 mm     | cu velcro    | 20 |
| 22066 | Ø 150 mm     | cu velcro    | 20 |

## DISC LUSTRIRE



| Nu.   | specificație |              |
|-------|--------------|--------------|
| 22070 | Ø 115 mm     | 20           |
| 22071 | Ø 125 mm     | cu velcro 20 |
| 22072 | Ø 150 mm     | 20           |

## FESTA

### SUPPORT PENTRU DISC VELCRO

- M14 | Ø 8 mm
- EVA 10 mm

| Nu.   | specificație |    |
|-------|--------------|----|
| 22062 | Ø 115 mm     | 25 |
| 22063 | Ø 125 mm     | 25 |
| 22064 | Ø 150 mm     | 10 |



## FESTA

### SUPPORT PENTRU DISC DE FIBRE



| Nu.   | specificație  |   |
|-------|---------------|---|
| 22073 | Ø 125 mm, M14 | 1 |
| 22074 | Ø 150 mm, M14 | 1 |



## FESTA

### SUPPORT PENTRU DISC VELCRO

- Pentru kutnica brusnicu
- pentru 24665-24667, 22701-22707

| Nu.   | specificație |             |
|-------|--------------|-------------|
| 22043 | Ø 100 mm     | cu velcro 1 |

### SUPPORT PENTRU DISC VELCRO

- Pentru kutnica brusnicu

| Nu.   | specificație |                  |
|-------|--------------|------------------|
| 22044 | Ø 125 mm     | M14 cu velcro 15 |
| 22060 | Ø 150 mm     | M14 cu velcro 6  |

## ADAPTER

| Nu.   | specificație |   |
|-------|--------------|---|
| 22087 |              | 1 |



Ø 6 mm

### SUPPORT PENTRU DISC VELCRO

| Nu.   | specificație |             |
|-------|--------------|-------------|
| 22061 | Ø 125 mm     | cu velcro 6 |

### SUPPORT PENTRU DISC VELCRO

| Nu.   | specificație |                    |
|-------|--------------|--------------------|
| 22041 | Ø 125 mm     | bind with screw 11 |
| 22042 | Ø 125 mm     | cu velcro 11       |



| Nu.   | specificație |        |
|-------|--------------|--------|
| 22091 | Ø 50 mm      | P240 1 |
| 22092 | Ø 75 mm      | P240 1 |
| 22093 | Ø 100 mm     | P240 1 |

## FESTA

### FIBER DISC - Ø 125 MM

3x



| Nu.   | asperity |   |
|-------|----------|---|
| 22160 | P40      | 1 |
| 22161 | P60      | 1 |
| 22162 | P80      | 1 |
| 22163 | P100     | 1 |
| 22164 | P120     | 1 |



## FESTA

### FIBER DISC - Ø 150 MM

3x



| Nu.   | asperity |   |
|-------|----------|---|
| 22167 | P80      | 1 |



**FESTA**

DISCURI ABRAZIVE VELCRO Ø 150 M

3x

| Nu.   | asperity |   |
|-------|----------|---|
| 22045 | P40      | 1 |
| 22046 | P60      | 1 |
| 22047 | P80      | 1 |
| 22048 | P100     | 1 |
| 22049 | P120     | 1 |
| 22050 | P150     | 1 |
| 22051 | P180     | 1 |
| 22052 | P220     | 1 |

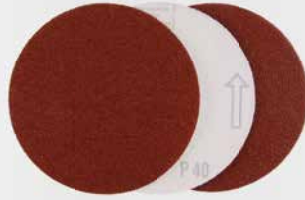

**FESTA**

DISCURI ABRAZIVE VELCRO Ø 125 MM

3x

| Nu.   | asperity |   |
|-------|----------|---|
| 22053 | P40      | 1 |
| 22054 | P60      | 1 |
| 22055 | P80      | 1 |
| 22056 | P100     | 1 |
| 22057 | P120     | 1 |

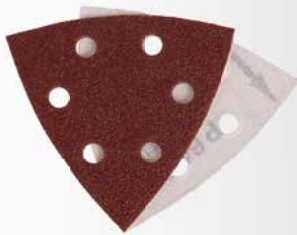

**FESTA**

SECȚIUNE VIBRARE OSA 94 X 94 X 94 MM

| Nu.   | asperity |   |
|-------|----------|---|
| 21831 | P60      | 1 |
| 21832 | P80      | 1 |
| 21834 | P120     | 1 |

3x

| Nu.   | asperity |    |
|-------|----------|----|
| 22096 | P40      | 20 |
| 22097 | P60      | 20 |
| 22098 | P80      | 20 |
| 22099 | P120     | 20 |

3x

| Nu.   | asperity |    |
|-------|----------|----|
| 21810 | P40      | 20 |
| 21811 | P60      | 20 |
| 21812 | P80      | 20 |
| 21813 | P100     | 20 |
| 21814 | P120     | 20 |



HARTIE ABRAZIVA 93 X 230 MM

5x

| Nu.   | asperity | numărul de găuri |    |
|-------|----------|------------------|----|
| 21740 | P40      | 8                | 20 |
| 21741 | P60      | 8                | 20 |
| 21742 | P80      | 8                | 20 |
| 21743 | P100     | 8                | 20 |
| 21744 | P120     | 8                | 20 |

HARTIE ABRAZIVA 115 X 280 MM

5x

| Nu.   | asperity | numărul de găuri |    |
|-------|----------|------------------|----|
| 21750 | P40      | 10               | 20 |
| 21751 | P60      | 10               | 20 |
| 21752 | P80      | 10               | 20 |
| 21753 | P100     | 10               | 20 |
| 21754 | P120     | 10               | 20 |



PANZA ABRAZIVA 230X280 MM

10x

| Nu.   | asperity |   |
|-------|----------|---|
| 21732 | P40      | 1 |
| 21734 | P60      | 1 |
| 21735 | P80      | 1 |
| 21736 | P100     | 1 |
| 21737 | P120     | 1 |

10x

| Nu.   | asperity |   |
|-------|----------|---|
| 21701 | P60      | 1 |
| 21702 | P80      | 1 |
| 21703 | P100     | 1 |
| 21704 | P120     | 1 |
| 21705 | P150     | 1 |
| 21706 | P180     | 1 |
| 21709 | P240     | 1 |

10x

| Nu.   | asperity |   |
|-------|----------|---|
| 21715 | P40      | 1 |
| 21716 | P60      | 1 |
| 21717 | P80      | 1 |
| 21718 | P100     | 1 |
| 21719 | P120     | 1 |
| 21720 | P150     | 1 |
| 21721 | P180     | 1 |
| 21724 | P240     | 1 |

HARTIE ABRAZIVA HIDROREZISTENTA

HARTIE ABRAZIVA 230X280 MM

**NEW**



**FESTA**

SUPORT  
CAUCIUC

· Ø 150 mm



| Nu.   | Specificație |   |
|-------|--------------|---|
| 22119 |              | 1 |

**FESTA**

SUPORT  
CAUCIUC

· prindere rapidă



| Nu.   | specificație |    |
|-------|--------------|----|
| 22067 | 170 x 70 mm  | 10 |

SUPORT  
CAUCIUC



| Nu.   | specificație |     |
|-------|--------------|-----|
| 22075 | 210 x 105 mm | 100 |
| 22076 | 160 x 85 mm  | 100 |

SUPORT  
CAUCIUC



| Nu.   | specificație |    |
|-------|--------------|----|
| 22077 | 125 x 68 mm  | 10 |

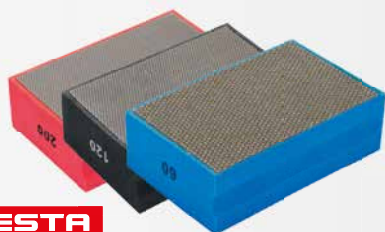

**FESTA**

BURETE DIAMANTAT ABRAZIV

· 90 x 55 x 25 mm  
· placi ceramice  
· sticlă  
· marmură  
· granit



| Nu.   | asperity |    |
|-------|----------|----|
| 22115 | P60      | 10 |
| 22116 | P120     | 10 |
| 22117 | P200     | 10 |

DISC ABRAZIV LAMELAR CU TIJA

| Nu.   | asperity | specificație    |   |
|-------|----------|-----------------|---|
| 21850 | P40      |                 | 1 |
| 21851 | P60      |                 | 1 |
| 21852 | P80      | 20 x 20, Ø 6 mm | 1 |
| 21853 | P100     |                 | 1 |
| 21854 | P120     |                 | 1 |
| 21855 | P40      |                 | 1 |
| 21856 | P60      |                 | 1 |
| 21857 | P80      | 30x30, Ø 6mm    | 1 |
| 21858 | P100     |                 | 1 |
| 21859 | P120     |                 | 1 |
| 21860 | P40      |                 | 1 |
| 21861 | P60      |                 | 1 |
| 21862 | P80      | 60x30, Ø 6mm    | 1 |
| 21863 | P100     |                 | 1 |
| 21864 | P120     |                 | 1 |



**FESTA**

BURETE ABRAZIV  
100 X 70 X 28 MM - TEȘITĂ



| Nu.   | asperity |    |
|-------|----------|----|
| 22106 | P 60     | 10 |
| 22107 | P 80     | 10 |
| 22108 | P 100    | 10 |
| 22109 | P 120    | 10 |



**FESTA**

BURETE ABRAZIV  
100 X 70 X 25 MM



| Nu.   | asperity |    |
|-------|----------|----|
| 22100 | P60      | 20 |
| 22101 | P80      | 20 |
| 22102 | P100     | 20 |
| 22103 | P120     | 20 |
| 22104 | P180     | 20 |
| 22105 | P220     | 20 |



**FESTA**

BURETE ABRAZIV  
120 X 95 X 10 MM



| Nu.   | asperity |    |
|-------|----------|----|
| 22110 | P80      | 20 |
| 22111 | P120     | 20 |
| 22112 | P180     | 20 |
| 22113 | P220     | 20 |



**FESTA**

| Nu.             | specificație  | nu. dinti |  |
|-----------------|---------------|-----------|---|
| <b>Ø 115 mm</b> |               |           |   |
| 22300           | Ø 115 x 22 mm | 40        | 1   |
| <b>Ø 125 mm</b> |               |           |   |
| 22301           | Ø 125 x 22 mm | 40        | 1   |
| <b>Ø 140 mm</b> |               |           |   |
| 22302           | Ø 140 x 20 mm | 24        | 1   |
| 22303           | Ø 140 x 20 mm | 30        | 1   |
| <b>Ø 150 mm</b> |               |           |   |
| 22305           | Ø 150 x 20 mm | 24        | 1   |
| <b>Ø 160 mm</b> |               |           |   |
| 22307           | Ø 160 x 20 mm | 18        | 1   |
| 22309           | Ø 160 x 20 mm | 24        | 1   |
| 22310           | Ø 160 x 20 mm | 30        | 1   |
| 22311           | Ø 160 x 20 mm | 36        | 1   |
| 22312           | Ø 160 x 20 mm | 48        | 1   |
| 22313           | Ø 160 x 20 mm | 60        | 1   |
| <b>Ø 165 mm</b> |               |           |   |
| 22314           | Ø 165 x 20 mm | 24        | 1   |
| <b>Ø 180 mm</b> |               |           |   |
| 22315           | Ø 180 x 30 mm | 24        | 1   |
| 22317           | Ø 180 x 30 mm | 50        | 1   |
| 22318           | Ø 180 x 20 mm | 50        | 1   |
| <b>Ø 185 mm</b> |               |           |   |
| 22316           | Ø 185 x 20 mm | 24        | 1   |
| <b>Ø 190 mm</b> |               |           |   |
| 22319           | Ø 190 x 20 mm | 40        | 1   |
| 22320           | Ø 190 x 30 mm | 40        | 1   |
| <b>Ø 200 mm</b> |               |           |   |
| 22322           | Ø 200 x 30 mm | 24        | 1   |
| 22324           | Ø 200 x 30 mm | 40        | 1   |
| 22326           | Ø 200 x 30 mm | 60        | 1   |
| <b>Ø 205 mm</b> |               |           |   |
| 22328           | Ø 205 x 30 mm | 40        | 1   |
| 22329           | Ø 205 x 30 mm | 60        | 1   |
| <b>Ø 210 mm</b> |               |           |   |
| 22332           | Ø 210 x 30 mm | 40        | 1   |
| 22333           | Ø 210 x 30 mm | 60        | 1   |
| <b>Ø 250 mm</b> |               |           |   |
| 22335           | Ø 250 x 30 mm | 40        | 1   |
| 22337           | Ø 250 x 30 mm | 60        | 1   |
| <b>Ø 300 mm</b> |               |           |   |
| 22340           | Ø 300 x 30 mm | 40        | 1   |
| 22343           | Ø 300 x 30 mm | 60        | 1   |
| 22345           | Ø 300 x 30 mm | 96        | 1   |
| <b>Ø 350 mm</b> |               |           |   |
| 22350           | Ø 350 x 30 mm | 40        | 1   |
| 22351           | Ø 350 x 30 mm | 54        | 1   |
| <b>Ø 400 mm</b> |               |           |   |
| 22355           | Ø 400 x 30 mm | 40        | 1   |
| 22357           | Ø 400 x 30 mm | 60        | 1   |
| <b>Ø 500 mm</b> |               |           |   |
| 22365           | Ø 500 x 30 mm | 60        | 1   |
| <b>Ø 600 mm</b> |               |           |   |
| 22370           | Ø 600 x 30 mm | 60        | 1   |

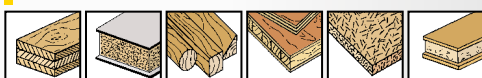
**FESTA****PANZA CIRCULAR TCT****INEL REDUCTIE**

| Nu.   | specificație |  |
|-------|--------------|---|
| 22399 | Ø 20   16 mm | 1   |
| 22398 | Ø 30   25 mm | 1   |



**FESTA**

SET DE ACCESORII CU MAI MULTE SCULE OSCILANTE

pentru 28045



4x

3x BI-METAL



1x SK5

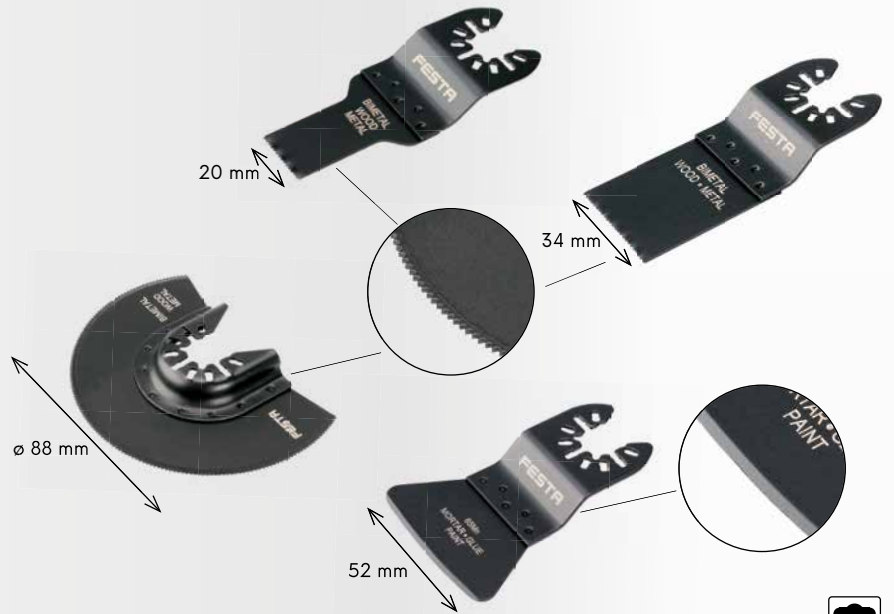

Nu. specificație  
24322



**FESTA**

SET DE ACCESORII CU MAI MULTE SCULE OSCILANTE

pentru 28045



4x

3x CARBIDE



1x

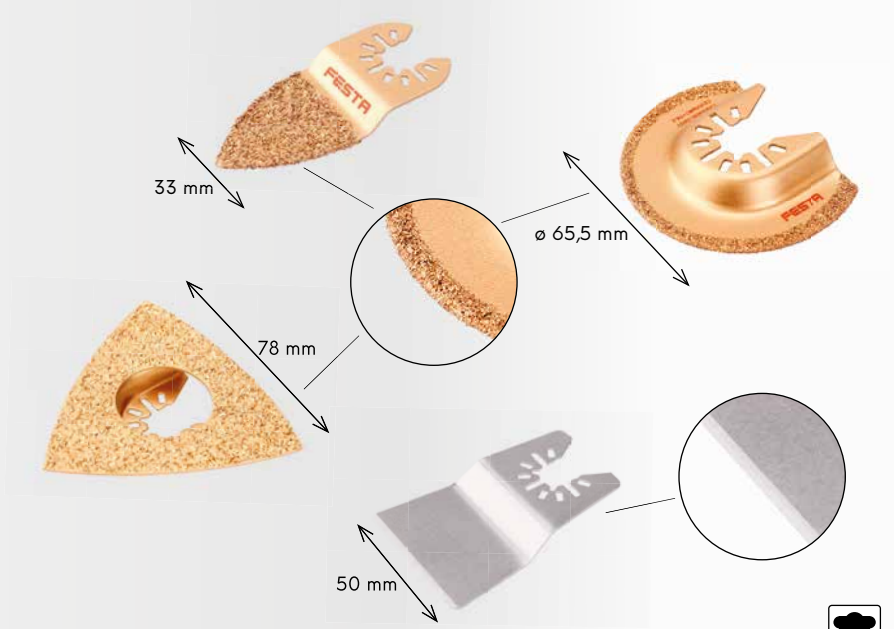

Nu. specificație  
24321



SET DE ACCESORII CU MAI MULTE SCULE OSCILANTE

pentru 28045



HCS 3x

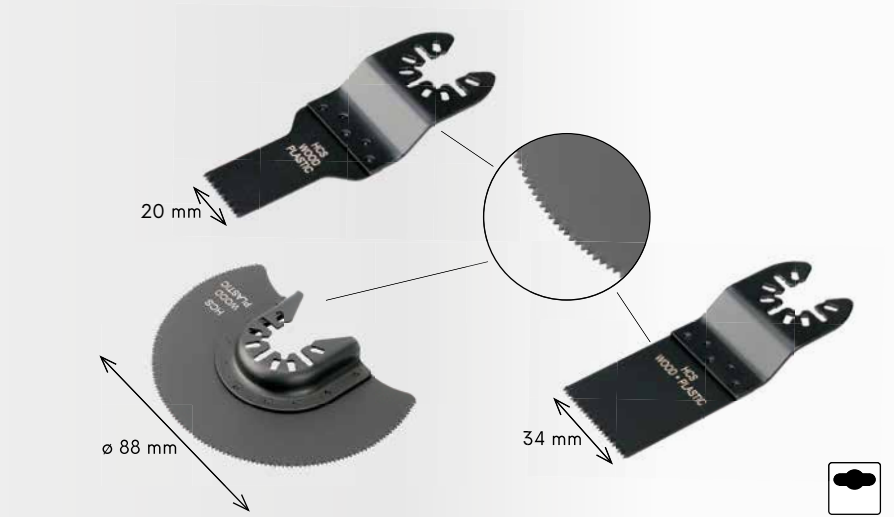

Nu. specificație  
24320



LAMA PROFESIONALE DE FERAȘTRAU  
FABRICAT IN GERMANIA CU TEHNOLOGIE LASER



LAME DE FERAȘTRAU HSS (AEG, BOSCH, FESTO, MAKITA, METABO)

|  |       |              |                           |       |       |    |  |
|--|-------|--------------|---------------------------|-------|-------|----|--|
|  | 24060 | 50mm/1mm     | 0,7 mm/ 36TPI             | 31007 | 5 buc | 10 |  |
|  | 24061 | 50mm/1mm     | 1,2 mm/ 21TPI             | 31012 | 5 buc | 10 |  |
|  | 24062 | 50mm/1mm     | 2,0 mm/ 13TPI             | 31020 | 5 buc | 10 |  |
|  | 24063 | 75mm/1mm     | 3,0 mm/ 8TPI              | 31030 | 5 buc | 10 |  |
|  | 24064 | 100mm/1mm    | 1,2 mm/ 21TPI             | 31112 | 5 buc | 10 |  |
|  | 24065 | 100mm/1,3mm  | 2,0 mm/ 13TPI             | 31112 | 5 buc | 10 |  |
|  | 24066 | 75mm/1,45mm  | 2,0 mm/ 13TPI             | 31220 | 5 buc | 10 |  |
|  | 24067 | 120mm/1,3mm  | 1,8 - 2,4 mm/ 10 - 14 TPI | 31220 | 5 buc | 10 |  |
|  | 24068 | 75mm/1,45mm  | 2,5 mm/ 10 TPI            | 32225 | 5 buc | 10 |  |
|  | 24069 | 75mm/1,45mm  | 4 mm/ 6 TPI               | 32240 | 5 buc | 10 |  |
|  | 24070 | 75mm/1,3mm   | 4 mm/ 6 TPI               | 32340 | 5 buc | 10 |  |
|  | 24071 | 75mm/1,3mm   | 4 mm/ 6 TPI               | 32440 | 5 buc | 10 |  |
|  | 24072 | 75mm/1,45mm  | 2,5 mm/ 10 TPI            | 32625 | 5 buc | 10 |  |
|  | 24073 | 85mm/1,45mm  | 3 mm/ 8 TPI               | 32730 | 5 buc | 10 |  |
|  | 24074 | 85mm/1,45mm  | 4 mm/ 6 TPI               | 32730 | 5 buc | 10 |  |
|  | 24075 | 75mm/1,45mm  | 2,5   1,2 mm/10   21 TPI  | 32825 | 5 buc | 10 |  |
|  | 24076 | 75mm/1,7mm   | 4 mm   6 TPI              | 32940 | 5 buc | 10 |  |
|  | 24077 | 120mm/1,3mm  | 4 mm   6 TPI              | 32040 | 5 buc | 10 |  |
|  | 24078 | 105mm/1,45mm | 4 mm   6 TPI              | 34040 | 5 buc | 10 |  |
|  | 24055 | 55mm         | karbid                    |       | 5 buc | 1  |  |

## LAME DE FERASTRUU HSS (BLACK & DECKER, SKIL)

|  |       |                |              |       |       |    |  |
|--|-------|----------------|--------------|-------|-------|----|--|
|  | 24080 | 50mm   1,0 mm  | 1,2   21 TPI | 11012 | 5 buc | 10 |  |
|  | 24081 | 75mm   1,0 mm  | 3,0   8 TPI  | 11030 | 5 buc | 10 |  |
|  | 24082 | 75mm   1,45 mm | 2,5   10 TPI | 12225 | 5 buc | 10 |  |
|  | 24083 | 75mm   1,45 mm | 4   6 TPI    | 12240 | 5 buc | 10 |  |
|  | 24084 | 75mm   1,3 mm  | 4   6 TPI    | 12340 | 5 buc | 10 |  |
|  | 24085 | 50mm   1,0 mm  | 2,0   13 TPI | 12420 | 5 buc | 10 |  |
|  | 24086 | 75mm   1,3 mm  | 4,0   6 TP   | 12440 | 5 buc | 10 |  |
|  | 24087 | 75mm   1,45 mm | 2,5   10 TPI | 12625 | 5 buc | 10 |  |

|  |                       |  |                    |  |                  |  |               |
|--|-----------------------|--|--------------------|--|------------------|--|---------------|
|  | otel moale            |  | foi de tabla       |  | otel inoxidabil  |  | pal melaminat |
|  | metale neferoase      |  | lemn tare si moale |  | pal              |  | plastic       |
|  | placaj                |  | panel              |  | scanduri cu cuie |  |               |
|  | material tip sandwich |  | pavaj              |  | aluminiu         |  |               |

## STAND PENTRU LAME DE FERASTRUU

|                             |       |
|-----------------------------|-------|
| stand cu lame 24098 - 24060 | 5 buc |
| 24080                       | 5 buc |
| 24061                       | 5 buc |
| 24062                       | 5 buc |
| 24081                       | 5 buc |
| 24063                       | 5 buc |
| 24066                       | 5 buc |
| 24067                       | 5 buc |
| 24082                       | 5 buc |
| 24068                       | 5 buc |
| 24083                       | 5 buc |
| 24069                       | 5 buc |
| 24084                       | 5 buc |
| 24070                       | 5 buc |
| 24086                       | 5 buc |
| 24071                       | 5 buc |
| 24087                       | 5 buc |
| 24072                       | 5 buc |
| 24073                       | 5 buc |
| 24074                       | 5 buc |
| 24075                       | 5 buc |
| 24076                       | 5 buc |



## LAME DE FERASTRUU, SET



5x

| Nu.   | specificatie |    |
|-------|--------------|----|
| 24045 | sada         | 50 |

| Nu.   | specificatie               |   |
|-------|----------------------------|---|
| 24099 | 64 x 50 cm - stand         | 1 |
| 24098 | 64 x 50 cm - stand cu lame | 1 |

**FESTA**

LAME DE FERASTRU

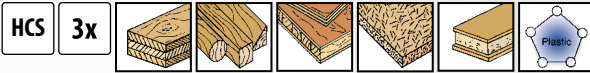

| Nu.   | specificatie            |   |
|-------|-------------------------|---|
| 24301 | 150 x 19 x 1,3 mm TPI 6 | 1 |

**FESTA**

LAME DE FERASTRU

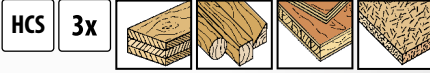

| Nu.   | specificatie            |   |
|-------|-------------------------|---|
| 24302 | 225 x 19 x 1,3 mm TPI 3 | 1 |

**FESTA**

LAME DE FERASTRU

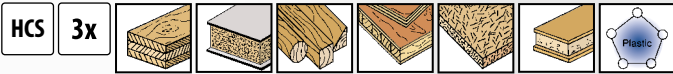

| Nu.   | specificatie                 |   |
|-------|------------------------------|---|
| 24303 | 200 x 19 x 1,3 mm TPI 6 - 10 | 1 |

**FESTA**

LAME DE FERASTRU

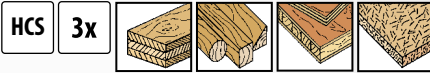

| Nu.   | specificatie            |   |
|-------|-------------------------|---|
| 24304 | 240 x 19 x 1,5 mm TPI 5 | 1 |

**FESTA**

LAME DE FERASTRU

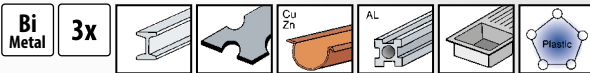

| Nu.   | specificatie           |   |
|-------|------------------------|---|
| 24305 | 150 x 19 x 1 mm TPI 24 | 1 |

**FESTA**

LAME DE FERASTRU

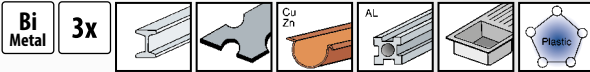

| Nu.   | specificatie          |   |
|-------|-----------------------|---|
| 24306 | 150 x 19 x 1 mm TPI 9 | 1 |

**FESTA**

LAME DE FERASTRU



| Nu.   | specificatie                |   |
|-------|-----------------------------|---|
| 24308 | 225 x 19 x 1 mm TPI 10 - 14 | 1 |

**FESTA**

LAME DE FERASTRU



| Nu.   | specificatie            |   |
|-------|-------------------------|---|
| 24310 | 150 x 22 x 1,6 mm TPI 9 | 1 |

**FESTA**

## LAME DE FERASTRUU

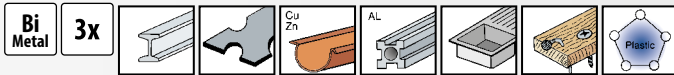

| Nu.   | specificație            |   |
|-------|-------------------------|---|
| 24313 | 225 x 22 x 1,6 mm TPI 6 | 1 |

**FESTA**

## LAME DE FERASTRUU

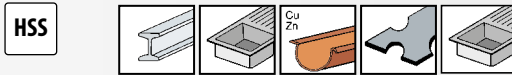

| Nu.   | specificație                |    |
|-------|-----------------------------|----|
| 24050 | 203 x 19 x 1 mm TPI 10 - 14 | 25 |

**FESTA**

## LAME DE FERASTRUU

· Tehnologia carburii

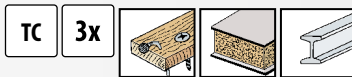

| Nu.   | specificație                |   |
|-------|-----------------------------|---|
| 24312 | 225 x 19 x 1,3 mm TPI 6 - 9 | 1 |

**FESTA**

## LAME DE FERASTRUU

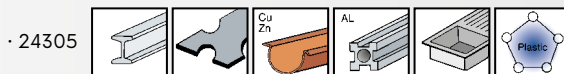
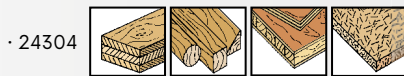
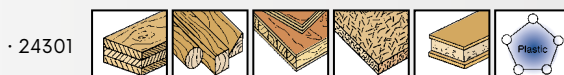

| Nu.   | specificație      |    |
|-------|-------------------|----|
| 24315 | 305 x 50 x 1,5 mm | 1  |
| 24316 | 455 x 50 x 1,5 mm | 25 |

**FESTA**

## SET LAME DE FERASTRUU



| Nu.   | specificație |   |
|-------|--------------|---|
| 24314 |              | 1 |

**FESTA**

## MÂNER PENTRU PÂNZE DE FERĂSTRĂU

· mâner + 2x pânză de ferăstrău  
 · pentru pânze de ferăstrău alternativ



| Nu.   | specificație |   |
|-------|--------------|---|
| 24325 |              | 1 |





**FESTA**  
**INDUSTRY**



## LAMA DE FERAȘTRAU

tratați termi



| Nu.   | specificație |   |
|-------|--------------|---|
| 24185 | 533 mm       | 1 |
| 24186 | 610 mm       | 1 |
| 24187 | 760 mm       | 1 |
| 24188 | 800 mm       | 1 |
| 24189 | 914 mm       | 1 |



## PANZA



| Nu.   | specificație                        |   |
|-------|-------------------------------------|---|
| 24195 | durata 3 mm   300 mm                | 1 |
| 24196 | durata 4 mm   300 mm oblică dinti   | 1 |
| 24197 | durata 5 mm   300 mm tratați termic | 1 |
| 24192 | lama pentru macara 450 mm           | 1 |

## PANZA

10x



| Nu.   | specificație  |   |
|-------|---------------|---|
| 24108 | 6 mm   150 mm | 1 |



## FESTA

## PANZA BI-METAL

8 % COBALT



| Nu.   | specificație |     |
|-------|--------------|-----|
| 24180 | 300 mm       | 125 |

## FESTA

## LAMA DE FERAȘTRAU

tratați termi



| Nu.   | specificație |    |
|-------|--------------|----|
| 24169 | 350 mm       | 10 |
| 24167 | 450 mm       | 10 |
| 24166 | 533 mm       | 10 |
| 24163 | 610 mm       | 10 |
| 24164 | 760 mm       | 10 |
| 24168 | 800 mm       | 10 |
| 24165 | 914 mm       | 10 |

## PANZE FERAȘTRAU

| Nu.   | specificație         |    |
|-------|----------------------|----|
| 24160 | durata 3 mm   300 mm | 20 |
| 24161 | durata 4 mm   300 mm | 20 |
| 24162 | durata 5 mm   300 mm | 50 |



## FIR CU CARBURA



| Nu.   | specificație |    |
|-------|--------------|----|
| 24120 | 300 mm       | 50 |



## FESTA

## PANZA



| Nu.   | specificație                              |     |
|-------|---|-----|
| 24109 | 12,5 mm   300 mm pentru metal             | 144 |
| 24118 | 25 mm   300 mm pentru metal, cu două fețe | 72  |
| 24119 | 25 mm   300 mm pentru metal și lemn       | 72  |



96

RULETA



101

METRU TAMPLARIE



104

ECHER



106

HORIZONT



112

LASERE



116

CREION TAMPLAR



120

SPRAYURI



122

CUTTER PROFESIONAL



137

DISPOZITIV PENTRU TAIAT TEVI



140

SURUBELNITE



146

BITS



154

SET CHEI TUBULARE



159

CHEI TUBULARE



164

CHEI COMBIMATE



169

CLESTE



179

FOARFECA PENTRU TABLA



182

DISPOZITIV PENTRU NITUIT



188

RASPILE SI FISIERE



190

FERASTRAU PENTRU METALE, LEMN



195

CIOCAN



203

DISPOZITIV PRINDERE



INSTRUMENTE DE ATELIER 94 - 205



# KOMELON®

· MĂSURI DE MĂSURĂ PREȚIOASĂ ȘI CALITATE

- II. Acuratete de clasa reg. CSN 251104, EEC 755345
- Rezistența de 10x mai mare a invelisului din nylon DURA NY Coat

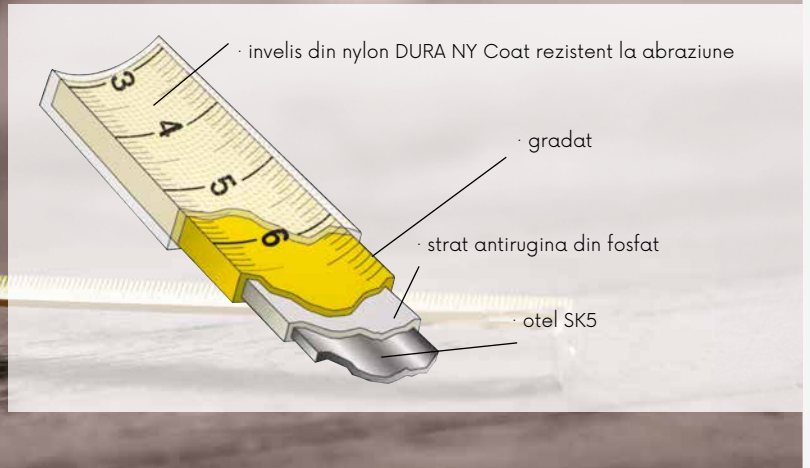

· Nylon rezistent la abraziune acoperiri DURA NY CoatTM



· Nylon rezistent la abraziune acoperiri DURA NY CoatTM



· Nylon rezistent la abraziune acoperiri DURA NY CoatTM

## KOMELON® RULETA

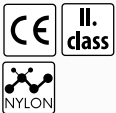

| Nu.   | specificație |    |
|-------|--------------|----|
| 10002 | 2 m · 16 mm  | 10 |
| 10003 | 3 m · 16 mm  | 10 |
| 10005 | 5 m · 19 mm  | 10 |
| 10008 | 8 m · 25 mm  | 10 |

## KOMELON® RULETA

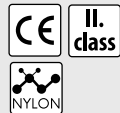

| Nu.   | specificație |    |
|-------|--------------|----|
| 10025 | 5 m · 25 mm  | 10 |

## KOMELON® RULETA

- frâna magnetică
- gumare antiderapanta

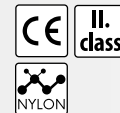

| Nu.   | specificație |   |
|-------|--------------|---|
| 10033 | 3 m · 16 mm  | 6 |
| 10035 | 5 m · 19 mm  | 6 |



## KOMELON® RULETA



| Nu.   | specificație |    |
|-------|--------------|----|
| 10043 | 3 m · 16 mm  | 30 |
| 10045 | 5 m · 19 mm  | 30 |
| 10048 | 8 m · 25 mm  | 12 |



## KOMELON® RULETA METALICA



| Nu.   | specificație |   |
|-------|--------------|---|
| 10110 | 10 m · 10 mm | 6 |
| 10120 | 20 m · 10 mm | 6 |
| 10130 | 30 m · 10 mm | 6 |



## KOMELON® RULETA FIBRA STICLA

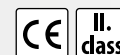

| Nu.   | specificație |   |
|-------|--------------|---|
| 10330 | 10 m · 13 mm | 6 |
| 10332 | 20 m · 13 mm | 6 |
| 10334 | 30 m · 13 mm | 6 |
| 10336 | 50 m · 13 mm | 6 |



**KOMELON®**  
RULETA FIBRA STICLA



| Nu.   | specificatie  |   |
|-------|---------------|---|
| 10430 | 30 m · 13 mm  | 1 |
| 10450 | 50 m · 13 mm  | 1 |
| 10490 | 100 m · 13 mm | 1 |



· fotografie ilustrativă

**STAND PROMOTIONAL**

| Nu.   | specificatie |   |
|-------|--------------|---|
| 10998 |              | 1 |

**KOMELON®**  
**STAND PROMOTIONAL**

· Elemente in stand 10996

|         |       |
|---------|-------|
| 10003 · | 5 buc |
| 10005 · | 4 buc |
| 10008 · | 1 buc |
| 10033 · | 2 buc |
| 10035 · | 3 buc |
| 10045 · | 2 buc |
| 10025 · | 3 buc |
| 10110 · | 1 buc |
| 10120 · | 1 buc |
| 10130 · | 1 buc |
| 10430 · | 1 buc |
| 10330 · | 1 buc |
| 10332 · | 1 buc |
| 10334 · | 1 buc |
| 10336 · | 1 buc |



· fotografie ilustrativă

| Nu.   | specificatie                |   |
|-------|-----------------------------|---|
| 10999 | stand promotional pt rulete | 1 |
| 10996 | stand echipat               | 1 |



· informatii despre banda



- A** · lungimea bandei
- B** · clasa de precizie
- C** · declaratia de conformitate - CE
- D** · data fabricatiei
- E** · numarul biroului de certificare acreditat care elibereaza certificatul
- F** · producător
- G** · reglarea speciala a benzii
- H** · temperatura la care sa facut testul

**FESTA**



**FESTA**

**RULETA**

- scala cu cifre mari
- protectie cauciuc antialunecare
- strat de Nylon



| Nu.   | specificatie |    |
|-------|--------------|----|
| 11353 | 3 m · 19 mm  | 12 |
| 11355 | 5 m · 19 mm  | 12 |
| 11356 | 5 m · 25 mm  | 12 |
| 11358 | 8 m · 25 mm  | 6  |
| 11360 | 10 m · 25 mm | 6  |



**FESTA**

**RULETA**

- strat de Nylon
- carcasa ABS
- clemă metalică acoperită cu crom
- frâna magnetica
- protectie cauciuc antialunecare PTE
- ureche de plastic



| Nu.   | specificatie  |   |
|-------|---------------|---|
| 11343 | 3 m · 16 mm   | 6 |
| 11345 | 5 m · 19 mm   | 6 |
| 11347 | 7,5 m · 25 mm | 6 |



**FESTA**

**RULETA**

- 3x frana
- cârlig magnetic
- incuia
- protectie cauciuc antialunecare PTE

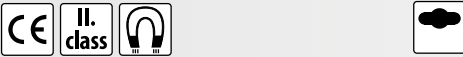

| Nu.   | specificatie  |    |
|-------|---------------|----|
| 11323 | 3 m · 19 mm   | 10 |
| 11325 | 5 m · 25 mm   | 10 |
| 11327 | 7,5 m · 25 mm | 6  |



**FESTA**

**RULETA**

- cârlig magnetic
- protectie cauciuc antialunecare PTE
- bandă fluorescentă
- scala cu cifre mari

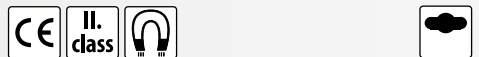

| Nu.   | specificatie  |    |
|-------|---------------|----|
| 11102 | 2 m · 16 mm   | 10 |
| 11103 | 3 m · 16 mm   | 10 |
| 11105 | 5 m · 19 mm   | 12 |
| 11106 | 5 m · 25 mm   | 12 |
| 11107 | 7,5 m · 25 mm | 10 |
| 11110 | 10 m · 25 mm  | 6  |



**FESTA**

**RULETA**

- scala cu cifre mari



| Nu.   | specificatie  |    |
|-------|---------------|----|
| 11226 | 2 m · 16 mm   | 10 |
| 11239 | 3 m · 19 mm   | 10 |
| 11259 | 5 m · 19 mm   | 12 |
| 11260 | 7,5 m · 25 mm | 6  |



**FESTA**

**RULETA**

- frâna magnetica
- protectie cauciuc antialunecare PTE

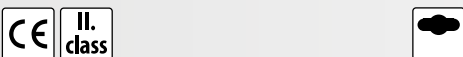

| Nu.   | specificatie  |    |
|-------|---------------|----|
| 11333 | 3 m · 16 mm   | 12 |
| 11335 | 5 m · 19 mm   | 12 |
| 11337 | 7,5 m · 25 mm | 6  |
| 11338 | 10 m · 25 mm  | 6  |



**FESTA**

**RULETA**

- dimensiuni mici ale benzii de măsurare
- strat de Nylon

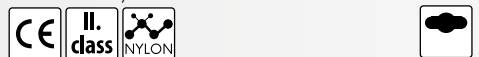

| Nu.   | specificatie |    |
|-------|--------------|----|
| 11220 | 3 m · 16 mm  | 12 |
| 11221 | 5 m · 19 mm  | 12 |



**Johnney®**

**RULETA**

· ajustare fina a benzii

**II. class**



| Nu.   | specificatie  |    |
|-------|---------------|----|
| 11002 | 2 m · 13 mm   | 12 |
| 11003 | 3 m · 13 mm   | 12 |
| 11005 | 5 m · 13 mm   | 12 |
| 11006 | 5 m · 19 mm   | 12 |
| 11007 | 7,5 m · 19 mm | 12 |
| 11008 | 10 m · 25 mm  | 12 |



**RULETA**

· incuia  
· protectie cauciuc antialunecare PTE



| Nu.   | specificatie |    |
|-------|--------------|----|
| 11082 | 2 m · 16 mm  | 12 |
| 11083 | 3 m · 16 mm  | 12 |
| 11085 | 5 m · 19 mm  | 12 |



**RULETA**

· combinatie de sistem metric si inch  
· protectie cauciuc antialunecare PTE



| Nu.   | specificatie |    |
|-------|--------------|----|
| 11416 | 5 m · 19 mm  | 10 |



**RULETA**

· incuia



| Nu.   | specificatie  |    |
|-------|---------------|----|
| 11200 | 2 m · 13 mm   | 24 |
| 11201 | 2 m · 16 mm   | 24 |
| 11202 | 2 m · 19 mm   | 24 |
| 11204 | 3 m · 13 mm   | 24 |
| 11205 | 3 m · 16 mm   | 24 |
| 11206 | 3 m · 19 mm   | 24 |
| 11207 | 5 m · 19 mm   | 12 |
| 11208 | 5 m · 25 mm   | 12 |
| 11209 | 7,5 m · 25 mm | 12 |
| 11210 | 10 m · 25 mm  | 12 |

**RULETA NUME, 3M · 16 MM**

**CE II. class**

| Č.p.  | jméno na metru | Č.p.  | jméno na metru | Č.p.  | jméno na metru | Č.p.  | jméno na metru |
|-------|----------------|-------|----------------|-------|----------------|-------|----------------|
| 13500 | JIŘÍ           | 13509 | MIROSLAV       | 13518 | VÁCLAV         | 13527 | MISTR          |
| 13501 | PETR           | 13510 | BIG BOSS       | 13519 | JAKUB          | 13528 | ONDŘEJ         |
| 13502 | JOSEF          | 13511 | ZDENĚK         | 13520 | LUKÁŠ          | 13529 | MAREK          |
| 13503 | TOMÁŠ          | 13512 | MICHAL         | 13521 | 2X MĚŘ         | 13530 | STANISLAV      |
| 13504 | JAN            | 13513 | MILAN          | 13522 | LADISLAV       | 13531 | BOREC          |
| 13505 | MARTIN         | 13514 | KAREL          | 13523 | DAVID          | 13532 | TATÍNEK        |
| 13506 | JAROSLAV       | 13515 | VLADIMÍR       | 13524 | ROMAN          | 13533 | ANTONÍN        |
| 13507 | FRANTIŠEK      | 13516 | DĚDEČEK        | 13525 | ŠIKULA         | 13534 | ALEŠ           |
| 13508 | PAVEL          | 13517 | MŮJ METR       | 13526 | RADEK          |       |                |



10



**FESTA**

**RULETA CU BANDA METAL**

· bucla

**CE II. class**



| Nu.   | specificatie |   |
|-------|--------------|---|
| 12010 | 10 m · 10 mm | 1 |
| 12020 | 20 m · 10 mm | 1 |
| 12030 | 30 m · 10 mm | 1 |
| 12050 | 50 m · 10 mm | 6 |



**FESTA**

**RULETA CU BANDA FIBRA STICLA**

· bucla

**CE II. class**



| Nu.   | specificatie |   |
|-------|--------------|---|
| 12110 | 10 m · 13 mm | 6 |
| 12120 | 20 m · 13 mm | 1 |
| 12130 | 30 m · 13 mm | 1 |
| 12150 | 50 m · 13 mm | 1 |



**FESTA**

**RULETA CU BANDA METAL**

· bucla + cârlig

**CE II. class**



| Nu.   | specificatie |   |
|-------|--------------|---|
| 12220 | 20 m · 10 mm | 6 |
| 12230 | 30 m · 10 mm | 6 |
| 12250 | 50 m · 10 mm | 6 |



**FESTA**

**RULETA CU BANDA METAL**

· bucla



| Nu.   | specificatie   |    |
|-------|----------------|----|
| 12433 | 30 m · 12,5 mm | 20 |
| 12435 | 50 m · 12,5 mm | 10 |



**ROATA MĂSURARE**

- rezistent, ușor și compact
- contorul adună în cazul micării înainte și scade în cazul micării înapoi
- luminat încorporat pentru munca în cursul nopții, 2 baterii aaa în mâner
- Sac



| Nu.   | specificatie |   |
|-------|--------------|---|
| 15989 | max. 10 km   | 2 |



**FESTA**

**DISPOZITIV TELESCOPIC PENTRU MASURAT INALTIMI**

· Sac

| Nu.   | specificatie |    |
|-------|--------------|----|
| 15983 | 0,7 - 3 m    | 10 |
| 15985 | 1,1 - 5 m    | 10 |
| 15988 | 1,6 - 8 m    | 5  |



**RULETA DE MĂSURARE AUTOADEZIVĂ**



| Nu.   | specificatie  |    |
|-------|---------------|----|
| 11311 | 1 m · 12,5 mm | 30 |
| 11312 | 2 m · 12,5 mm | 30 |
| 11313 | 3 m · 16 mm   | 30 |
| 11314 | 5 m · 19 mm   | 30 |



**RULETA BRELOC CHEI**

| Nu.   | specificatie         |    |
|-------|----------------------|----|
| 11420 | 1 m · 6 mm portocale | 24 |



**FESTA**

**RULETA BRELOC CHEI**

- scala cu cifre mari
- properties of classical measuring tape



| Nu.   | specificatie           |    |
|-------|------------------------|----|
| 11410 | 2 m · 16 mm 6 colorate | 12 |



**RULETA BRELOC CHEI**

| Nu.   | specificatie   |    |
|-------|----------------|----|
| 11444 | 1 m · 6 mm alb | 20 |



**RULETA BRELOC CHEI**

| Nu.   | specificatie |    |
|-------|--------------|----|
| 11425 | 1 m · 6 mm   | 25 |



**BRELOC FIOLA**

| Nu.   | specificatie |     |
|-------|--------------|-----|
| 11445 |              | 100 |

METRU TAMPLARIE LEMN



| Nu.   | specificatie       |    |
|-------|--------------------|----|
| 13010 | 1 m · alb          | 20 |
| 13020 | 2 m · alb          | 10 |
| 13021 | 1 m · galben       | 20 |
| 13022 | 2 m · galben       | 10 |
| 13023 | 2 m · alb - galben | 10 |

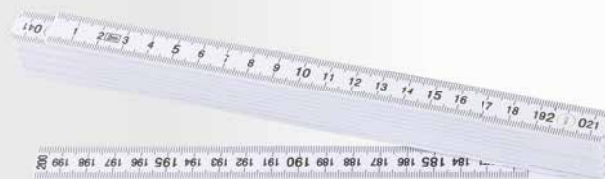
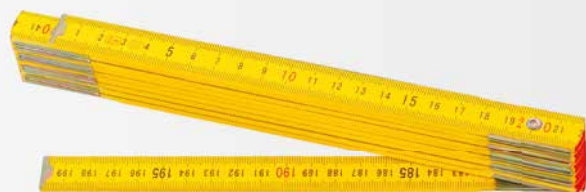

METRU TAMPLARIE LEMN



| Nu.   | specificatie |    |
|-------|--------------|----|
| 13111 | 1 m · galben | 10 |
| 13120 | 2 m · galben | 5  |



METRU TAMPLARIE LEMN



| Nu.   | specificatie |   |
|-------|--------------|---|
| 13211 | 1 m          | 1 |
| 13220 | 2 m          | 1 |

METRU TAMPLARIE LEMN CU NUME



| Nu.   | nume în metru |
|-------|---------------|
| 13401 | JIŘÍ          |
| 13402 | JAN           |
| 13403 | PETR          |
| 13404 | JOSEF         |
| 13405 | PAVEL         |
| 13406 | MARTIN        |
| 13407 | JAROSLAV      |
| 13408 | TOMÁŠ         |
| 13409 | MIROSLAV      |
| 13410 | ZDENĚK        |
| 13411 | FRANTIŠEK     |
| 13412 | VÁCLAV        |
| 13413 | MICHAL        |
| 13414 | MILAN         |
| 13415 | KAREL         |
| 13416 | JAKUB         |
| 13417 | LUKÁŠ         |
| 13418 | DAVID         |
| 13419 | VLADIMÍR      |
| 13420 | LADISLAV      |
| 13421 | ONDŘEJ        |
| 13422 | ROMAN         |
| 13423 | STANISLAV     |
| 13424 | MAREK         |
| 13425 | RADEK         |

| Nu.   | nume în metru |
|-------|---------------|
| 13426 | DANIEL        |
| 13427 | ANTONÍN       |
| 13428 | VOJTĚCH       |
| 13429 | FILIP         |
| 13430 | ADAM          |
| 13431 | MILOSLAV      |
| 13432 | MATĚJ         |
| 13433 | ALEŠ          |
| 13434 | JAROMÍR       |
| 13435 | LIBOR         |
| 13436 | DOMINIK       |
| 13437 | PATRIK        |
| 13438 | VLASTIMIL     |
| 13439 | JINDŘICH      |
| 13440 | MILOŠ         |
| 13441 | JÁN           |
| 13442 | PETER         |
| 13443 | ONDŘEJ        |
| 13444 | JOZEF         |
| 13445 | PAVOL         |
| 13446 | L'UBOMÍR      |
| 13447 | KAROL         |
| 13448 | RADOSLAV      |
| 13449 | VOJTĚCH       |
| 13450 | ZDENKO        |

| Nu. | nume în metru |
|-----|---------------|
| 10  |               |

| Nu.   | nume în metru |
|-------|---------------|
| 13451 | JANA          |
| 13452 | EVA           |
| 13453 | PETRA         |
| 13454 | MAJKA         |
| 13455 | HANA          |
| 13456 | ANNA          |
| 13457 | LENKA         |
| 13458 | KATKA         |
| 13459 | LUCIE         |
| 13460 | ALENA         |
| 13461 | VERONIKA      |
| 13462 | MARTINA       |
| 13463 | JITKA         |
| 13464 | BIG BOSS      |
| 13465 | 2 x MĚŘ       |
| 13466 | TATÍNEK       |
| 13467 | DĚDEČEK       |
| 13468 | ŠIKULA        |
| 13469 | MISTR         |
| 13470 | MACHR         |
| 13471 | BOREC         |
| 13472 | UŽ JE MŮJ     |
| 13473 | MŮJ METR      |

STAND METRU TAMPLARIE

Elementele din stand 13399

- 13401 · 15 buc
- 13402 · 15 buc
- 13403 · 15 buc
- 13404 · 15 buc
- 13405 · 15 buc
- 13406 · 15 buc
- 13412 · 15 buc
- 13413 · 15 buc
- 13414 · 15 buc
- 13415 · 15 buc
- 13416 · 15 buc
- 13417 · 15 buc
- 13418 · 15 buc
- 13419 · 15 buc
- 13420 · 15 buc
- 13421 · 10 buc
- 13422 · 10 buc
- 13423 · 10 buc
- 13424 · 10 buc
- 13425 · 10 buc
- 13426 · 10 buc
- 13427 · 10 buc
- 13428 · 10 buc
- 13429 · 10 buc
- 13430 · 10 buc
- 13431 · 10 buc
- 13432 · 10 buc
- 13433 · 10 buc
- 13434 · 10 buc
- 13435 · 10 buc
- 13436 · 10 buc
- 13437 · 10 buc
- 13438 · 10 buc
- 13439 · 10 buc
- 13440 · 10 buc



| Nu.   | specificatie                    |   |
|-------|---------------------------------|---|
| 13399 | Stand plin cu benzi de măsurare | 1 |
| 13400 | Stand fără elemente             | 1 |



**FESTA**

**SUBLER DIGITAL**



| INOX | Nu.   | specificatie  |    |
|------|-------|---------------|----|
|      | 14007 | 150   0,01 mm | 10 |
|      | 14008 | 200   0,01 mm | 10 |
|      | 14009 | 300   0,01 mm | 10 |



**SUBLER DIGITAL**

· acuratete 0.2 mm, resolution 0.1 mm

| Nu.   | specificatie |    |
|-------|--------------|----|
| 14013 | 150   0,2 mm | 10 |

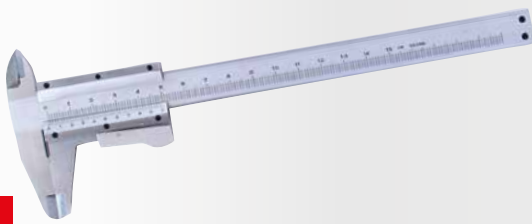

**FESTA**

**SUBLER**



| INOX | Nu.   | specificatie  |    |
|------|-------|---------------|----|
|      | 14004 | 150   0,02 mm | 10 |

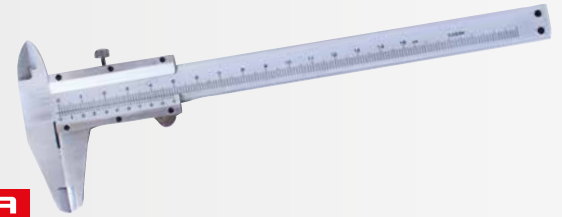

**FESTA**

**SUBLER**



| INOX | Nu.   | specificatie  |    |
|------|-------|---------------|----|
|      | 14001 | 150   0,02 mm | 10 |
|      | 14002 | 200   0,02 mm | 10 |
|      | 14003 | 300   0,02 mm | 10 |



**FESTA**

**MICROMETRU**



| Nu.   | specificatie       |    |
|-------|--------------------|----|
| 14040 | 0 - 0,25   0,01 mm | 10 |
| 14045 | 25 - 50   0,01 mm  | 10 |



**SUBLER**

**HOBBY**

| PLASTIC | Nu.   | specificatie |    |
|---------|-------|--------------|----|
|         | 14006 | 150 mm       | 50 |



**FESTA**

**CEAS COMPARATOR**



| INOX | Nu.   | specificatie       |    |
|------|-------|--------------------|----|
|      | 14035 | 0 - 10mm   0,01 mm | 10 |



**LERE PENTRU GROSIME**

· 20 frunze



| Nu.   | specificatie |    |
|-------|--------------|----|
| 14080 | 0,05 - 1 mm  | 10 |



**COMPAS DE TRASAT**



| Nu.   | specificatie |    |
|-------|--------------|----|
| 13285 | 200 mm       | 10 |



**FESTA**

**CREION TRASARE**



| Nu.   | specificatie |    |
|-------|--------------|----|
| 13281 | 150 mm       | 50 |



**FESTA**

**CREION TRASARE**



| Nu.   | specificatie |    |
|-------|--------------|----|
| 13282 | 200 mm       | 50 |



**FESTA**

RIGLĂ CU MÂNER

ALU



| Nu.   | specificație |   |
|-------|--------------|---|
| 14030 | 600 mm       | 6 |

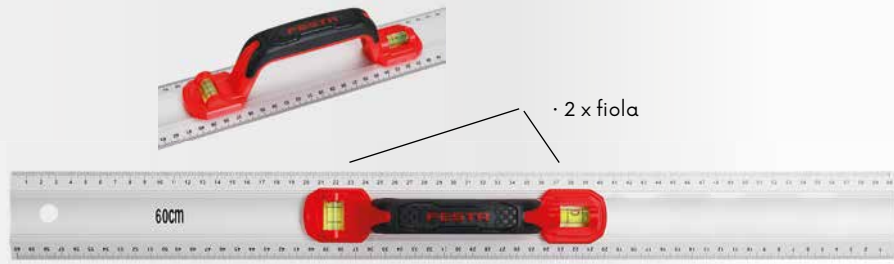

**FESTA**

RIGLA ALU

ALU



| Nu.   | specificație |    |
|-------|--------------|----|
| 14015 | 400 mm       | 48 |
| 14017 | 600 mm       | 50 |
| 14019 | 1000 mm      | 40 |



**FESTA**

RIGLA INOX

INOX



| Nu.   | specificație |    |
|-------|--------------|----|
| 14010 | 300 mm       | 10 |
| 14011 | 600 mm       | 10 |
| 14012 | 1000 mm      | 10 |

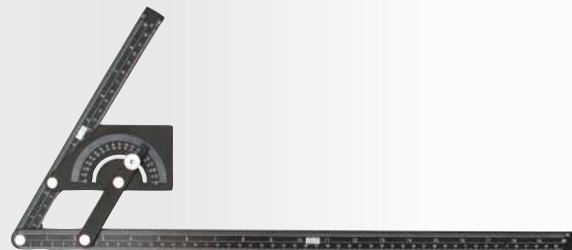
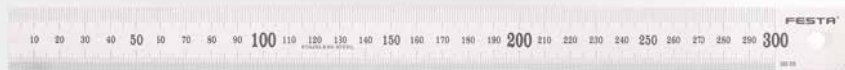

**FESTA**

RAPORTOR

· Sac

| Nu.   | specificație             |    |
|-------|--------------------------|----|
| 14060 | 0° - 180° · 150 x 200 mm | 10 |
| 14070 | 0° - 180° · 300 x 500 mm | 5  |

RAPORTOR

HOBBY

| Nu.   | specificație             |    |
|-------|--------------------------|----|
| 14075 | 0° - 180° · 230 x 500 mm | 30 |



ECHER MULTIFUNCȚIONAL

| Nu.   | Specificație |
|-------|--------------|
| 14077 |              |



10

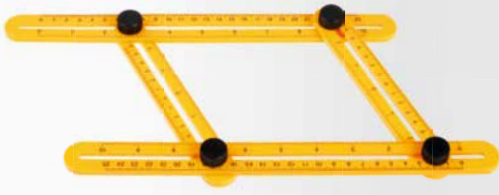

**ECHER MULTIFUNCȚIONAL**



| Nu.   | specificație |   |
|-------|--------------|---|
| 14480 | 250 x 120 mm | 1 |



· blocare

**ȘABLON PENTRU COPIEREA FORMELOR**



| Nu.   | specificație |   |
|-------|--------------|---|
| 14090 | 125 x 30 mm  | 1 |
| 14091 | 250 x 30 mm  | 1 |

**FESTA**

**ECHER MULTIFUNCȚIONAL 3D**



| Nu.   | specificație |    |
|-------|--------------|----|
| 14418 |              | 10 |



**FESTA**

**ECHER ALUMINIU**



| Nu.   | specificație |    |
|-------|--------------|----|
| 14420 | 180 mm       | 10 |
| 14421 | 300 mm       | 10 |

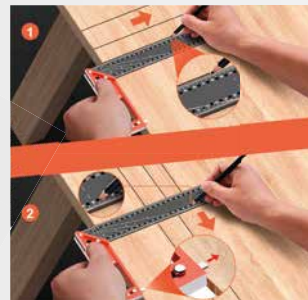
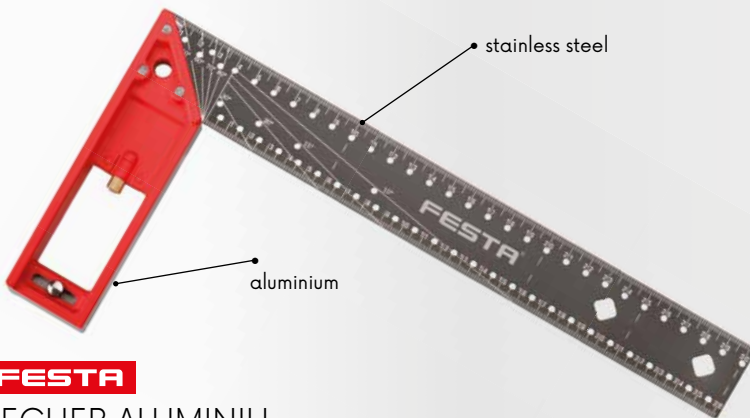

**FESTA**

**ECHER ALUMINIU**



| Nu.   | Specification |   |
|-------|---------------|---|
| 14415 | 300 mm        | 6 |
| 14417 | 400 mm        | 6 |

**FESTA**

**ECHER ZIDARIE**

**ALU**



| Nu.   | specificație   |   |
|-------|----------------|---|
| 14445 | 600 x 600 mm   | 1 |
| 14446 | 1200 x 1200 mm | 1 |



**FESTA**

**ECHER REGLABIL**

**ALU**



| Nu.   | specificație |   |
|-------|--------------|---|
| 14450 | 190 x 355 mm | 6 |
| 14451 | 200 x 405 mm | 6 |

**FESTA**

**ECHER ALUMINIU**



| Nu.   | specificație |    |
|-------|--------------|----|
| 14220 | 200 x 125 mm | 10 |
| 14225 | 250 x 135 mm | 10 |
| 14230 | 300 x 135 mm | 10 |
| 14235 | 350 x 190 mm | 10 |
| 14240 | 400 x 190 mm | 10 |
| 14250 | 500 x 210 mm | 10 |

**FESTA**

**ECHER TAMPLARIE**



| Nu.   | specificație  |    |
|-------|---------------|----|
| 14350 | 500 x 235 mm  | 10 |
| 14360 | 600 x 300 mm  | 10 |
| 14370 | 700 x 300 mm  | 10 |
| 14380 | 800 x 320 mm  | 10 |
| 14399 | 1000 x 360 mm | 10 |



**ECHER**

| Nu.   | specificație |    |
|-------|--------------|----|
| 14410 | 300 x 200 mm | 50 |
| 14411 | 600 x 400 mm | 36 |

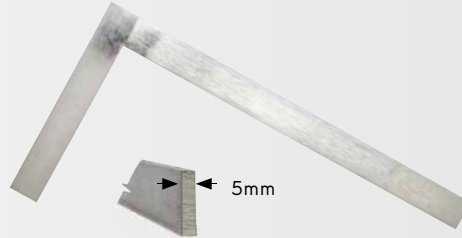

**ECHER PLAT**

**Zn**

| Nu.   | specificație |    |
|-------|--------------|----|
| 14471 | 150 x 100 mm | 25 |
| 14472 | 250 x 125 mm | 25 |
| 14473 | 400 x 200 mm | 30 |
| 14474 | 600 x 300 mm | 25 |

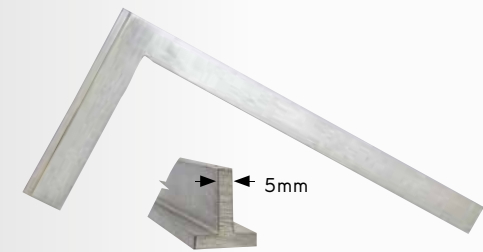

**ECHER CU TALPA**

**Zn**

| Nu.   | specificație |    |
|-------|--------------|----|
| 14490 | 100 x 50 mm  | 10 |
| 14491 | 150 x 75 mm  | 10 |
| 14492 | 250 x 125 mm | 10 |
| 14493 | 400 x 200 mm | 10 |
| 14494 | 600 x 300 mm | 10 |



**ECHER ZIDARIE**

| Nu.   | specificație  |    |
|-------|---------------|----|
| 14455 | 300 x 200 mm  | 50 |
| 14456 | 500 x 250 mm  | 50 |
| 14457 | 700 x 300 mm  | 40 |
| 14458 | 1000 x 450 mm | 30 |



**ECHER ALUMINIU**

**ALU HOBBY**

| Nu.   | specificație |    |
|-------|--------------|----|
| 14425 | 250 x 130 mm | 12 |
| 14430 | 300 x 130 mm | 12 |
| 14435 | 350 x 156 mm | 12 |
| 14440 | 400 x 156 mm | 12 |



**ECHER REGLABIL**



| Nu.   | specificație |   |
|-------|--------------|---|
| 14025 | 255 x 285 mm | 1 |

MADE IN EUROPE

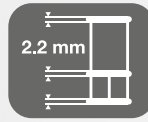
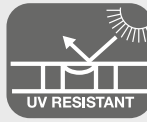
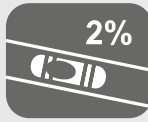
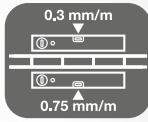

Fiecare bucata este testata electronic si are numar de serie. Producatorul este detinatorul certifi catului ISO 90001



**HORIZONT<sup>®</sup>**  
**MASTER**



**HORIZONT<sup>®</sup>**

NIVELA MASTER CU 2 BULE

ALU

| Nu.   | specificatie |    |
|-------|--------------|----|
| 15033 | 60 cm        | 10 |



**HORIZONT<sup>®</sup>**

NIVELA MASTER CU 3 BULE

ALU

| Nu.   | specificatie |    |
|-------|--------------|----|
| 15034 | 80 cm        | 10 |
| 15035 | 100 cm       | 10 |



**HORIZONT<sup>®</sup>**

NIVELA MASTER CU 3 BULE, 2 MANERE

ALU

| Nu.   | specificatie |    |
|-------|--------------|----|
| 15036 | 120 cm       | 10 |
| 15037 | 150 cm       | 10 |
| 15039 | 200 cm       | 10 |

# HORIZONT®

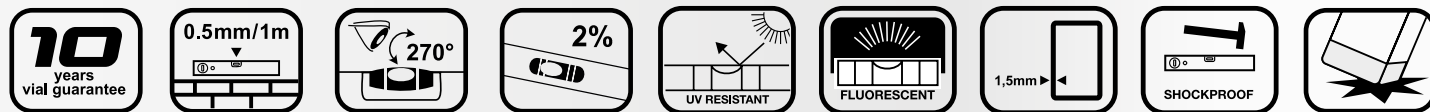

Fiecare bucata este testata electronic si are numar de serie Producatorul este detinatorul certifi catului ISO 90001

## HORIZONT®

### NIVELA ALUMINIU 2 BULE



| Nu.   | specificatie |    |
|-------|--------------|----|
| 15003 | 30 cm        | 30 |
| 15004 | 40 cm        | 30 |
| 15005 | 50 cm        | 30 |
| 15006 | 60 cm        | 30 |
| 15008 | 80 cm        | 30 |
| 15010 | 100 cm       | 30 |
| 15012 | 120 cm       | 10 |
| 15015 | 150 cm       | 10 |
| 15018 | 180 cm       | 10 |
| 15020 | 200 cm       | 10 |



## HORIZONT®

### NIVELA ALUMINIU 3 BULE



| Nu.   | specificatie |    |
|-------|--------------|----|
| 15103 | 30 cm        | 30 |
| 15104 | 40 cm        | 30 |
| 15105 | 50 cm        | 30 |
| 15106 | 60 cm        | 30 |
| 15108 | 80 cm        | 30 |
| 15110 | 100 cm       | 30 |
| 15112 | 120 cm       | 10 |
| 15115 | 150 cm       | 10 |
| 15118 | 180 cm       | 10 |
| 15120 | 200 cm       | 10 |



## HORIZONT®

### NIVELA ALUMINIU 2 BULE + MAGNETI FIXARE



| Nu.   | specificatie |    |
|-------|--------------|----|
| 15204 | 40 cm        | 30 |
| 15205 | 50 cm        | 30 |
| 15206 | 60 cm        | 30 |
| 15208 | 80 cm        | 30 |
| 15210 | 100 cm       | 30 |
| 15212 | 120 cm       | 10 |
| 15215 | 150 cm       | 10 |
| 15218 | 180 cm       | 10 |
| 15220 | 200 cm       | 10 |



## HORIZONT®

### NIVELA PENTRU INCLINATII 4 BULE



| Nu.   | specificatie |    |
|-------|--------------|----|
| 15230 | 80 cm        | 10 |



**HORIZONT**  
NIVELA PENTRU INCLINATII



| Nu.   | specificatie |   |
|-------|--------------|---|
| 15235 | 60 cm        | 1 |



**HORIZONT**  
DREPTAR ALU



| Nu.   | specificatie |    |
|-------|--------------|----|
| 15310 | 100 cm       | 10 |
| 15315 | 150 cm       | 10 |
| 15318 | 180 cm       | 10 |
| 15320 | 200 cm       | 10 |
| 15325 | 250 cm       | 10 |
| 15330 | 300 cm       | 10 |
| 15335 | 350 cm       | 10 |
| 15340 | 400 cm       | 10 |



**HORIZONT**  
DREPTAR ALU 1 BULA



| Nu.   | specificatie |    |
|-------|--------------|----|
| 15415 | 150 cm       | 10 |
| 15418 | 180 cm       | 10 |
| 15420 | 200 cm       | 10 |
| 15425 | 250 cm       | 10 |
| 15430 | 300 cm       | 10 |



**HORIZONT**  
DREPTAR ALU 1 BULA



| Nu.   | specificatie |    |
|-------|--------------|----|
| 15510 | 100 cm       | 10 |
| 15515 | 150 cm       | 10 |
| 15518 | 180 cm       | 10 |
| 15520 | 200 cm       | 10 |
| 15525 | 250 cm       | 10 |
| 15530 | 300 cm       | 10 |
| 15535 | 350 cm       | 10 |
| 15540 | 400 cm       | 5  |



**HORIZONT**  
DREPTAR ALU 2 MANERE



| Nu.   | specificatie |    |
|-------|--------------|----|
| 15615 | 150 cm       | 10 |
| 15620 | 200 cm       | 10 |
| 15625 | 250 cm       | 10 |
| 15630 | 300 cm       | 10 |



**HORIZONT.**

DREPTAR ALU 2 BULE + 2 MANERE

ALU

| Nu.   | specificatie |    |
|-------|--------------|----|
| 15710 | 100 cm       | 10 |
| 15715 | 150 cm       | 10 |
| 15720 | 200 cm       | 10 |
| 15725 | 250 cm       | 10 |
| 15730 | 300 cm       | 10 |
| 15735 | 350 cm       | 10 |
| 15740 | 400 cm       | 5  |



**HORIZONT.**

DREPTAR ALU PROFIL TRAPEZ

PROFIL TRAPEZOIDAL

- Profilul trapezoidal servește pentru finisarea mai fină a suprafeței
- Adecvat pentru stucatori și realizatori fațade
- Adecvat pentru tencuieli în strat subțire

ALU

| Nu.   | specificatie |    |
|-------|--------------|----|
| 15810 | 100 cm       | 10 |
| 15812 | 120 cm       | 10 |
| 15815 | 150 cm       | 10 |
| 15818 | 180 cm       | 10 |
| 15820 | 200 cm       | 10 |
| 15825 | 250 cm       | 10 |
| 15830 | 300 cm       | 10 |



**HORIZONT.**

DREPTAR ALU PROFIL H

Profil „h”

- Profilul „h” servește pentru finisarea mai fină de suprafață
- Adecvat pentru stucatori și realizatori fațade
- Adecvat pentru tencuirea cu stuc

ALU

| Nu.   | specificatie |    |
|-------|--------------|----|
| 15850 | 100 cm       | 10 |
| 15853 | 150 cm       | 10 |
| 15855 | 180 cm       | 10 |
| 15860 | 200 cm       | 10 |
| 15870 | 250 cm       | 10 |
| 15880 | 300 cm       | 10 |

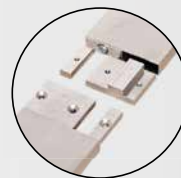

NEW

**HORIZONT.**

AMBREIAJ  
PENTRU DREPTAR  
HORIZONT

| Nu.   | specificatie |   |  |
|-------|--------------|---|--|
| 15301 |              | 1 |  |



**HORIZONT.**

DREPTAR ALU 1 BULA  
REGLABIL



| Nu.   | specificatie |   |
|-------|--------------|---|
| 15893 | 65 - 100 cm  | 1 |
| 15894 | 95 - 150 cm  | 1 |
| 15895 | 145 - 235 cm | 1 |



**HORIZONT.**

ECHER ZIDARIE

ALU

| Nu.   | specificatie   |   |
|-------|----------------|---|
| 14485 | 800 x 1200 mm  | 1 |
| 14486 | 1000 x 1500 mm | 1 |



**HORIZONT.**  
STAND PENTRU  
NEVELE HORIZONT

· elementele din stand 15998

- 15003 · 5 buc
- 15004 · 5 buc
- 15005 · 5 buc
- 15006 · 5 buc
- 15008 · 5 buc
- 15010 · 5 buc
- 15012 · 5 buc
- 15015 · 3 buc
- 15018 · 3 buc
- 15020 · 3 buc
- 15108 · 3 buc
- 15206 · 3 buc
- 15210 · 3 buc

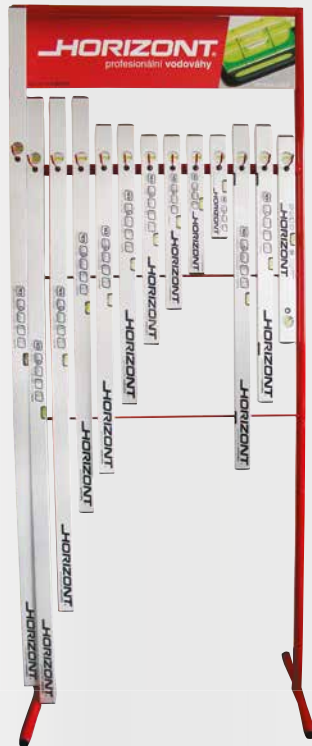

**HORIZONT.**  
STAND PENTRU  
NEVELE HORIZONT

· elementele din stand 15996

- 15004 · 5 buc
- 15005 · 5 buc
- 15006 · 5 buc
- 15008 · 5 buc
- 15010 · 5 buc
- 15012 · 5 buc
- 15015 · 5 buc
- 15018 · 5 buc
- 15020 · 5 buc
- 15315 · 2 buc
- 15320 · 2 buc
- 15325 · 3 buc
- 15515 · 2 buc
- 15520 · 2 buc
- 15525 · 3 buc



| Nu.   | specificatie             |   |
|-------|--------------------------|---|
| 15999 | 85 x 210 x 50 cm         | 1 |
| 15998 | 85 x 210 x 50 cm osazený | 1 |

| Nu.   | specificatie            |   |
|-------|-------------------------|---|
| 15997 | 55 x 75 x 40 cm         | 1 |
| 15996 | 55 x 75 x 40 cm osazený | 1 |

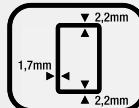
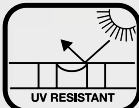
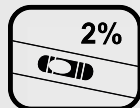

**NEW**

**FESTO**  
NIVELA ALU,  
3 BULE



| Nu.   | specificatie |   |
|-------|--------------|---|
| 15754 | 400 mm       | 1 |
| 15756 | 600 mm       | 1 |
| 15758 | 800 mm       | 1 |
| 15760 | 1000 mm      | 1 |
| 15762 | 1200 mm      | 1 |
| 15768 | 1800 mm      | 1 |
| 15770 | 2000 mm      | 1 |





**NIVELA**

**NIVELA TIP NIVELA**

- Precizie 0,5 mm | 1 m
- Lichid Uv stabil nivelă cu bulă de aer
- Manșoane terminale de gumă rezistente la impact
- Grosime manta 1,2m



| Nu.   | specificatie |    |
|-------|--------------|----|
| 15904 | 40 cm        | 30 |
| 15906 | 60 cm        | 30 |
| 15908 | 80 cm        | 30 |
| 15910 | 100 cm       | 30 |
| 15912 | 120 cm       | 20 |
| 15915 | 150 cm       | 10 |
| 15920 | 200 cm       | 20 |



**NIVELA ALU, GALBENA, 3 BULE**



| Nu.   | specificatie |    |
|-------|--------------|----|
| 15954 | 40 cm        | 60 |
| 15956 | 60 cm        | 60 |
| 15958 | 80 cm        | 60 |
| 15960 | 100 cm       | 30 |
| 15962 | 120 cm       | 30 |
| 15965 | 150 cm       | 30 |
| 15970 | 200 cm       | 30 |



**NIVELA CU BULA PENTRU MIRE**



| Nu.   | specificatie |   |
|-------|--------------|---|
| 15981 |              | 1 |



| Nu.   | specificatie |   |
|-------|--------------|---|
| 15980 | 230 mm       | 1 |

**NIVELA CU FIOLA PENTRU MIRE**

- 3 fiole magneti curea



| Nu.   | specificatie |    |
|-------|--------------|----|
| 26028 |              | 12 |



**FURTUN CU BULE DE NIVEL**



| Nu.   | specificatie           |    |
|-------|------------------------|----|
| 15992 | fiole + furtun de 10 m | 1  |
| 15993 | fiole + furtun de 15 m | 1  |
| 15990 | fiole de sticla        | 50 |
| 15991 | fiole de plastic       | 50 |



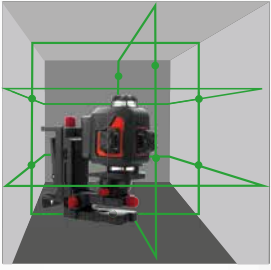

**NEW**

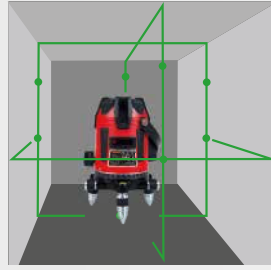

**NEW**



**FESTA**

**LASER ALL LINE GREEN 4 X 360 °**

- 2x plan orizontal + 2x plan vertical (fascicul verde)
- interval de autonivelare ±4°
- precizie: 0,2 mm/m
- interior 30 m, cu receptor laser pana la 50 m
- modul puls – receptor accesoriu recomandat 26209
- livrat cu: cutie de transport, telecomanda, tinta laser, Baterie Li-ion 5200 mAh, suport profesional, mini trepied, încărcător

|      |           |           |                   |        |
|------|-----------|-----------|-------------------|--------|
| ±4°  | max. 50 m | ±0.2 mm/m | II. class         | 515 nm |
| 1/4" | 5/8"      | IP54      | Li-ion 3.7V 5.2Ah |        |

|       |              |   |
|-------|--------------|---|
| Nu.   | specificatie |   |
| 26205 |              | 1 |



**FESTA**

**LASER VERDE ÎNCRUCIȘAT**

- 1x plan orizontal + 4x plan vertical (fascicul verde) + 1x punct
- interval de autonivelare ±3°
- precizie: 0,2 mm/m
- în interior 20 m, cu receptor laser până la 50 m
- modul puls – receptor accesoriu recomandat 26209
- livrat cu: cutie de transport, tinta laser, Baterie Li-ion 5200 mAh, suport profesional, mini trepied, încărcător

|      |           |                   |           |        |
|------|-----------|-------------------|-----------|--------|
| ±3°  | max. 50 m | ±0.2 mm/m         | II. class | 515 nm |
| 5/8" | IP54      | Li-ion 3.7V 5.2Ah |           |        |

|       |              |   |
|-------|--------------|---|
| Nu.   | specificatie |   |
| 26203 |              | 1 |





**FESTA**

**LASER ALL LINE GREEN 3 X 360 °**

- 1x plan orizontal + 2x plan vertical (fascicul verde)
- interval de autonivelare  $\pm 4^\circ$
- precizie 0,2 mm/m
- interior: 30 m, exterior cu detector 50 m
- modul puls – receptor accesoriu recomandat 26209
- inclusiv: husă de transport, 4 baterii alcaline AA, țintă laser, ochelari de protecție, baterie Li-ion de 2600 mAh, suport profesional, încărcător, suport pentru baterie Li-ion

|               |                             |                   |           |                   |
|---------------|-----------------------------|-------------------|-----------|-------------------|
| $\pm 4^\circ$ | INDOOR 30 m<br>OUTDOOR 50 m | $\pm 0.2$<br>mm/m | II. class | 515 nm            |
| IP54          | 5/8"                        | 1/4"              | 4x AA     | Li-ion 7.4V 2.6Ah |



| Nu.   | specificație |
|-------|--------------|
| 26204 | green        |



1



**FESTA**

**LASER VERDE ÎNCRUCIȘAT**

- 1x plan orizontal + 1x plan vertical (fascicul verde)
- interval de autonivelare  $\pm 3^\circ$
- precizie 0,2 mm/m
- interior: 20 m, exterior cu detector 50 m
- modul puls – receptor accesoriu recomandat 26209
- inclusiv: husă de transport, 2 baterii alcaline AA, suport

|               |                             |                   |           |        |
|---------------|-----------------------------|-------------------|-----------|--------|
| $\pm 3^\circ$ | INDOOR 20 m<br>OUTDOOR 50 m | $\pm 0.2$<br>mm/m | II. class | 515 nm |
| IP54          | 1/4"                        | 2x AA             |           |        |

| Nu.   | specificație |
|-------|--------------|
| 26201 | green        |



1

**FESTA**

**TELEMETRU**

- domeniu de măsurare 0,05 - 50 m
- precizie de măsurare  $\pm 2$  mm, unitate de măsură mm/in/ft
- măsurarea continuă, măsurarea suprafeței, măsurarea volumului, măsurare picior triunghi, LCD FSTN, adunare/scădere, max./min. mesurament, stocare maxima 100 unitati, iluminare din spate, clasa laser 630-670 nm clasa 2
- temperatura de functionare 0 - 40°C
- dimensiune 112 x 50 x 25 mm, greutate 90 g
- inclusiv: husă de transport, 2 baterii alcaline AAA

|          |               |               |                  |
|----------|---------------|---------------|------------------|
| max 50 m | $\pm 2$<br>mm | m<br>in<br>ft | 630<br>670<br>nm |
| IP54     | 2x AAA        |               |                  |

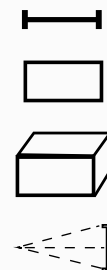

| Nu.   | specificație |
|-------|--------------|
| 26211 |              |



1



**FESTA**

**RECEPTOR LASER**

- pentru utilizare cu dispozitive laser pulsate pentru a extinde raza de acțiune până la 50 m
- inclusiv: baterie de 9 V, suport
- pentru 26201, 26203, 26204, 26205

|                   |                      |             |             |              |
|-------------------|----------------------|-------------|-------------|--------------|
| <b>max</b><br>50m | <b>±1.5mm</b><br>10m | <b>5kHz</b> | <b>IP54</b> | <b>1x 9V</b> |
|-------------------|----------------------|-------------|-------------|--------------|



| Nu.   | specificație |   |
|-------|--------------|---|
| 26209 | range: 50 m  | 1 |

1/4" + 5/8"



60 - 150 cm

**TREPIED**

**ALU**



| Nu.   | specificație            |   |
|-------|-------------------------|---|
| 26219 | 60 - 150 cm 1/4" + 5/8" | 1 |

**FESTA**

**INCLINOMETRU DIGITAL**

- 0° - 360°
- precizie ±0,1°
- rezoluție 0,1°
- funcția de oprire automată
- Funcția HOLD pentru stocarea valorilor măsurate
- ecran de iluminare din spate
- dimensiuni 60x60x25 mm
- baterie 1xAAA



· bag

· magnetic bottom side

|                             |               |               |            |
|-----------------------------|---------------|---------------|------------|
| <b>84.5°</b><br>LCD DISPLAY | <b>1x AAA</b> | <b>0-50°C</b> | <b>82g</b> |
|-----------------------------|---------------|---------------|------------|

| Nu.   | specificație |   |
|-------|--------------|---|
| 26218 |              | 1 |



**FESTA**

**RAPORTOR DIGITAL**

|               |                  |                       |                     |
|---------------|------------------|-----------------------|---------------------|
| <b>200 mm</b> | <b>mm / inch</b> | <b>LCD DISPLAY</b>    | <b>0°-360°</b>      |
| <b>0.05°</b>  | <b>+/- 0.2°</b>  | <b>MANUAL LOCKING</b> | <b>1x CR2032 3V</b> |



| Nu.   | specificație |   |
|-------|--------------|---|
| 26217 | 200 mm       | 1 |



**FESTA**

**NIVELA DIGITALA DL**

- LCD Afișa
- Interval de măsurare 0° - 225°
- Distincție 0,1°
- Precizie ± 0,3

|            |                              |                   |
|------------|------------------------------|-------------------|
| <b>ALU</b> | <b>044.8°</b><br>LCD DISPLAY | <b>3V LITHIUM</b> |
|------------|------------------------------|-------------------|



| Nu.   | specificație |   |
|-------|--------------|---|
| 26216 | 300 mm       | 1 |

**FESTA**

**MULTIMETRUL**

- Măsurarea tensiunii DC: 200 mV - 300 V
- Măsurarea tensiunii AC: 200 mV - 300 V
- Măsurare curent continuu: 2000  $\mu$ A - 10 A
- măsurarea rezistenței: 200  $\Omega$  - 2 M $\Omega$
- verificare baterie: 1,5 V, 9 V
- indicație baterie descărcată
- protecție la suprasarcina

- IEC61010
- CATIII 300 V
- Certificat GS
- alimentare: baterie de 9 V (6F22)
- dimensiuni: 70x128x28 mm
- greutate: 137 g (cu baterie)
- accesorii: cabluri de testare



Nu. specificație  
**18429**



1



**FESTA**

**TESTER DE TENSIUNE**

- AC/DC - 6V, 12V, 24V, 50V, 120V, 230V, 400V
- rezistența la apă IP54
- determinarea polarității
- CAT III 400V



Nu. specificație  
**18428**



1



**Laserliner®**

**LUXTEST-MASTER**

Aparat de măsură profesionist pentru intensitatea iluminatului

- Măsurarea intensității iluminatului la posturile de lucru, birouri, clădiri publice și în industrie
- Fotodiode sensibile cu corecție cosinus pentru măsurarea în unghi lat a luminii
- Funcții relative de măsurare pentru măsurarea și comparația de referință
- Funcție avansată pentru înregistrarea modificării rapide la nivelul iluminatului.
- Funcția reținerii automate a valorii.
- Comutare gamă automat și manual
- Funcția aducerii la zero
- Măsurarea variabilei: Lux (lm/m<sup>2</sup>), lumânări de picior (lm/ft<sup>2</sup>) - Min./ afișaj max.
- 1/4" filet pentru montare pe stativ



Nu. specificație

Gama de măsurare: 20 Lux . . . 200000 Lux

**26520** Precizie:  $\pm 3\%$  (lampa de referință la 2854 K)

Abatere unghiulară cosinus:  $\pm 2\%$  (30°),  $\pm 6\%$  (60°)



1

specificație

Livrat cu: baterie, carcasă

**Laserliner®**

**AIRFLOWTEST-MASTER**

Anemometru profesionist pentru măsurarea debitului de aer, a debitului volumetric și a vitezei vântului

- Senzor integrat pentru măsurarea temperaturii ambiante, a umidității relative a punctului de rouă
- interfață USB pentru salvarea datelor măsurate
- PC software
- Roată alergătoare mare: 65 mm.
- Min. | Max. afișaj - filet de 1/4" pentru fixare pe stativ în scopul măsurării pe termen lung
- Afișaj iluminat, sistematic, cu valori de temperatură și umiditate relativă ambiante vizibile permanent



Nu. specificație

Debitul: 0.80...30 m |s |  $\pm 2\%$

**26521** Temperatura ambientală: -10...60°C |  $\pm 1.5^\circ\text{C}$

Umiditatea relativă: 20%...80% |  $\pm 3\%$

Flux de aer: 0...99990 CMM



RECORDING ON A PC

specificație

Livrat cu: AirflowTest-Master, software, cablu USB, baterii, carcasă



1



**FESTA**

CREION TAMPLAR HB



MOQ  
12

| Nu.   | specificatie            |    |
|-------|-------------------------|----|
| 13270 | HB · 180 mm             | 96 |
| 13271 | HB · 180 mm · set 3 buc | 32 |
| 13265 | HB · 250 mm             | 96 |



**FESTA**

CREION TAMPLAR HB



MOQ  
50

| Nu.   | specificatie |    |
|-------|--------------|----|
| 13269 | HB · 180 mm  | 50 |
| 13266 | HB · 250 mm  | 50 |



**FESTA**

CREION TAMPLAR HB



MOQ  
12

| Nu.   | specificatie                 |    |
|-------|------------------------------|----|
| 13272 | HB · 250 mm                  | 96 |
| 13264 | HB · 250 mm · fără imprimare | 96 |



**FESTA**

CREION TAMPLAR HB



MOQ  
50

| Nu.   | specificatie |    |
|-------|--------------|----|
| 13268 | 250 mm       | 50 |



**FESTA**

CREION TRIUNGHIULAR HB



MOQ  
12

| Nu.   | specificatie |    |
|-------|--------------|----|
| 13278 | 250 mm       | 96 |



**FESTA**

CREION TAMPLAR 6H

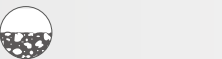

MOQ  
12

| Nu.   | specificatie |    |
|-------|--------------|----|
| 13275 | 6H · 250 mm  | 96 |



**FESTA**

STICLA SI CERAMIC



MOQ  
12

| Nu.   | specificatie                            |     |
|-------|---|-----|
| 13273 | 175 mm, roșu grafit - sticla si ceramic | 144 |



**FESTA**

CREION TAMPLAR

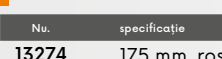

MOQ  
12

| Nu.   | specificatie          |    |
|-------|-----------------------|----|
| 13274 | 175 mm, roșu-albastru | 96 |



CREION TAMPLAR HB



MOQ  
12

| Nu.   | specificație |    |
|-------|--------------|----|
| 13280 | 180 mm       | 96 |



CREION ROSU GRAFIT

MOQ  
12

| Nu.   | specificație |     |
|-------|--------------|-----|
| 13276 | 175 mm       | 144 |



șlefuire hârtie

ASCUTITOARE CREION



| Nu.   |  |    |
|-------|--|----|
| 13261 |  | 12 |



NEW

FESTA

CREION METALIC CU CLIP HB

grafit de schimb 13263, 13267



| Nu.   | specificație |    |
|-------|--------------|----|
| 13288 |              | 20 |



FESTA

CREION METALIC CU CLIP HB

grafit de schimb 13263, 13267



| Nu.   | specificație |    |
|-------|--------------|----|
| 13262 | 150 mm       | 20 |



FESTA

CREION CU MINĂ GRAFIT AMOVIBILĂ



| Nu.   | specificație                 |    |
|-------|------------------------------|----|
| 13279 | creion + grafit de schimb hb | 24 |
| 13284 | grafit 5 buc                 | 20 |

FESTA

CREIOANE COLORATE

pentru 13262, 13288



| Ș.p.  | Specifikație                  |   |
|-------|-------------------------------|---|
| 13267 | 2x galben 2x roșu 2x albastru | 1 |



FESTA

CREIOANE NEGRE HB

pentru 13262, 13288



| Ș.p.  | Specifikație |    |
|-------|--------------|----|
| 13263 | 6x negru     | 20 |



**FESTA**  
INDUSTRY

**MARKER PERMANENT**

| Nu.   | specificatie |   |
|-------|--------------|---|
| 13200 | alb          | 1 |
| 13201 | negru        | 1 |
| 13202 | roșu         | 1 |

**NEW**

**MARKER PERMANENT**

- vârf extrem de puternic
- Pentru marcare chiar și pe suprafețe grase și umede

**MOQ**  
12

| Nu.   | specificatie |    |
|-------|--------------|----|
| 13216 | roșu         | 12 |
| 13217 | negru        | 12 |
| 13218 | albastru     | 12 |
| 13219 | verde        | 12 |

**MARKER PERMANENT**

- 2 tipuri de vârf ale dispozitivului de marcare
- Pentru marcare chiar și pe suprafețe grase și umede



| Nu.   | specificatie |                |
|-------|--------------|----------------|
| 13227 | alb          | ALU pouzdro 40 |
| 13222 | alb          | PVC pouzdro 12 |
| 13228 | roșu         | ALU pouzdro 40 |
| 13229 | negru        | ALU pouzdro 40 |
| 13230 | albastru     | ALU pouzdro 12 |
| 13231 | verde        | ALU pouzdro 12 |

**MARKER PERMANENT**

**MOQ**  
12

| Nu.   | specificatie |    |
|-------|--------------|----|
| 13214 | alb          | 12 |
| 13225 | roșu         | 12 |
| 13226 | negru        | 12 |
| 13223 | albastru     | 12 |
| 13224 | verde        | 12 |

**MARKER PERMANENT**

**MOQ**  
12

| Nu.   | specificatie |    |
|-------|--------------|----|
| 13235 | roșu         | 12 |
| 13236 | negru        | 12 |
| 13237 | albastru     | 12 |
| 13238 | verde        | 12 |





**FESTA**

MARKER PERMANENT



| Nu.   | specificație |   |
|-------|--------------|---|
| 13246 | ● negru      | 1 |
| 13247 | ● roșu       | 1 |
| 13248 | ○ alb        | 1 |



MARKER PERMANENT - 2 DIMENSIUNI DE VÂRF



MOQ 12



| Nu. / No. | Specificație |    |
|-----------|--------------|----|
| 13206     | ○ alb        | 12 |



MARKER PERMANENT - 2 DIMENSIUNI DE VÂRF



MOQ 12



| Nu.   | specificație |    |
|-------|--------------|----|
| 13212 | negru        | 12 |



MARKER PERMANENT - 2 DIMENSIUNI DE VÂRF



MOQ 12



| Nu. / No. | Specificație |    |
|-----------|--------------|----|
| 13207     | ● roșu       | 12 |
| 13208     | ● albastru   | 12 |



MARKER PERMANENT MINI



· lungime 9 cm



MOQ 72



| Nu.   | specificație |    |
|-------|--------------|----|
| 13205 | ● ● ● ●      | 72 |



**FESTA**

**CREION CEARA**  
5 BUC  
· Ø 13 x 110 mm

**5x**



| Nu.   | specificatie |    |
|-------|--------------|----|
| 13240 | 5 culoare    | 20 |
| 13241 | roșu         | 20 |
| 13242 | negru        | 20 |

| Nu.   | specificatie |    |
|-------|--------------|----|
| 13243 | galben       | 20 |
| 13244 | verde        | 20 |
| 13245 | alb          | 20 |



**SUPPORT MOBIL**  
**PENTRU SPRAY SOPEC**

· pentru pulverizare trackmarker and Fluo



| Nu.   | specificatie |   |
|-------|--------------|---|
| 13296 |              | 1 |



**CREION CEARA**  
6 BUC

**6x**



| Nu.   | specificatie |    |
|-------|--------------|----|
| 13277 |              | 88 |



**CRETĂ ALBĂ**

**12x**



| Nu.   | specificatie    |    |
|-------|-----------------|----|
| 13260 | 12 x 12 x 80 mm | 46 |



**SUPPORT TIP PISTOL PENTRU SPRAY SOPEC**

· pentru pulverizare trackmarker and Fluo



| Nu.   | specificatie |   |
|-------|--------------|---|
| 13295 |              | 1 |



### SPRAYURI FLUORESCENT TRACKMARKER 500 ML

- Vizibilitate ridicată datorită pigmentului fluorescent
- Cap de siguranță
- Uscare rapidă 10 min.
- Durabilitate 3 luni
- Utilizare - beton, asfalt, iarbă, pietriș, nisip, piatră, lemn



| Nu.   | specificație |    |
|-------|--------------|----|
| 13250 | galben       | 12 |
| 13251 | roșu         | 12 |
| 13252 | portocale    | 12 |
| 13253 | verde        | 12 |
| 13254 | roz          | 12 |
| 13249 | albastru     | 12 |



### SPRAYURI FLUORESCENT MARK 6M FLUO 500 ML

- Vizibilitate ridicată datorită pigmentului fluorescent
- Cap de siguranță
- Uscare rapidă 10 min.
- Durabilitate 6 luni
- Utilizare - beton, asfalt, iarbă, pietriș, nisip, piatră, lemn



| Nu.   | specificație |    |
|-------|--------------|----|
| 13360 | galben       | 12 |
| 13361 | roșu         | 12 |
| 13362 | portocale    | 12 |
| 13363 | verde        | 12 |
| 13364 | roz          | 12 |
| 13365 | alb          | 12 |



### SPRAYURI FLUORESCENT FLUO 500 ML

- Vizibilitate ridicată datorită pigmentului fluorescent
- Cap de siguranță
- Uscare rapidă 10 min.
- Durabilitate 12 luni
- Utilizare - beton, asfalt, iarbă, pietriș, nisip, piatră, lemn



| Nu.   | specificație |    |
|-------|--------------|----|
| 13350 | galben       | 12 |
| 13351 | roșu         | 12 |
| 13352 | portocale    | 12 |
| 13353 | verde        | 12 |
| 13354 | roz          | 12 |
| 13355 | alb          | 12 |



### SPRAYURI FLUORESCENT IDEAL 500 ML

- Vizibilitate ridicată datorită pigmentului fluorescent
- Cap de siguranță
- Uscare rapidă 10 min.
- Durabilitate 12 luni
- Utilizare - beton, asfalt, iarbă, pietriș, nisip, piatră, lemn



| Nu.   | specificație |    |
|-------|--------------|----|
| 13255 | galben       | 12 |
| 13256 | roșu         | 12 |
| 13257 | portocale    | 12 |
| 13258 | verde        | 12 |
| 13259 | roz          | 12 |



# KDS®

Knives of Japanese company KDS

- excellent ergonomics of grips
- high performance and lifespan of blades
- blades of the best materials
- low cutting resistance enabling easy cutting



## KDS® CUTTER PROFESIONAL



| Nu.   | specificatie      |    |  |
|-------|-------------------|----|--|
| 16002 | LC405 18 mm verde | 25 |  |
| 16011 | LB10 lame rezerva | 10 |  |



## KDS® CUTTER PROFESIONAL



| Nu.   | specificatie       |    |  |
|-------|--------------------|----|--|
| 16003 | G11 18 mm + 2 lame | 10 |  |
| 16012 | GB10 lame rezerva  | 10 |  |



## KDS® CUTTER PROFESIONAL



| Nu.   | specificatie       |    |  |
|-------|--------------------|----|--|
| 16019 | L19 18 mm + 2 lame | 10 |  |
| 16011 | LB10 lame rezerva  | 10 |  |
| 16012 | GB10 lame rezerva  | 10 |  |



## KDS® CUTTER PROFESIONAL

| Nu.   | specificatie      |    |  |
|-------|-------------------|----|--|
| 16004 | H11 25 mm         | 10 |  |
| 16013 | HB10 lame rezerva | 10 |  |



## KDS® CUTTER PROFESIONAL



| Nu.   | specificatie      |    |  |
|-------|-------------------|----|--|
| 16005 | S14 9 mm + 2 lame | 10 |  |
| 16010 | SB10 lame rezerva | 10 |  |



## KDS® CUTTER PROFESIONAL



| Nu.   | specificatie  |    |  |
|-------|---------------|----|--|
| 16006 | D12 + 16 lame | 10 |  |

## KDS® LAME REZERVA



| Nu.   | specificatie     |             |    |
|-------|------------------|-------------|----|
| 16010 | SB10 9   0,38 mm | 13 segmente | 20 |
| 16011 | LB10 18   0,5 mm | 15 segmente | 20 |
| 16012 | GB10 18   0,6 mm | 15 segmente | 20 |
| 16013 | HB10 25   0,7 mm | 7 segmente  | 10 |



## KDS® LAME REZERVA

- aliaj special
- dubla ascutire
- durata de viata ridicata
- rezistenta mica la taiere care permite taierea cu usurinta



| Nu.   | specificatie      |            |    |
|-------|-------------------|------------|----|
| 16016 | LB10B 18   0,5 mm | 8 segmente | 20 |
| 16017 | HB10B 25   0,7 mm | 7 segmente | 10 |



## KDS® STATIV DE PROMOVARE KDS

| Nu.   | specificatie        |   |  |
|-------|---------------------|---|--|
| 16999 | stativ de promovare | 1 |  |
| 16998 | sta cu elemente     | 1 |  |



- Articolele din standul 16998 : 16001 - 5 buc
- 16003 - 5 buc
- 16004 - 3 buc
- 16005 - 3 buc
- 16006 - 2 buc
- 16008 - 3 buc
- 16010 - 4 buc
- 16012 - 4 buc
- 16013 - 1 buc
- 16016 - 4 buc
- 16018 - 4 buc
- 16019 - 4 buc
- 16020 - 4 buc

• fotografie ilustrativă



**FESTA**



sistem de rupere a lamei



**CUTTER PROFESIONAL**

· Acoperire din cauciuc antiderapant



| Nu.   | specificatie |    |
|-------|--------------|----|
| 16099 | 18 mm        | 12 |

**FESTA**



**CUTTER LAME CERAMICE**

· 3x sharper than the steel blade  
· 10x longer lifetime  
· Refractory, non-conductive, non-magnetic



| Nu.   | specificatie              |    |
|-------|---------------------------|----|
| 16131 | 18 mm                     | 10 |
| 16066 | lame rezerva 18 mm, 5 buc | 10 |



**CUTTER PROFESIONAL**



| Nu.   | specificatie       |    |
|-------|--------------------|----|
| 16110 | L11 18 mm + 1 lame | 12 |



**CUTTER PROFESIONAL**



| Nu.   | specificatie       |    |
|-------|--------------------|----|
| 16100 | L12 18 mm + 1 lame | 12 |

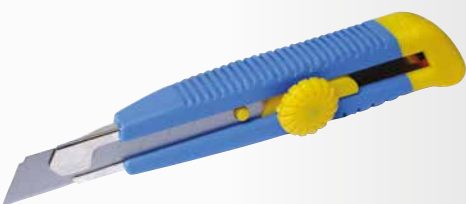

**CUTTER PROFESIONAL**



| Nu.   | specificatie       |    |
|-------|--------------------|----|
| 16105 | L17 18 mm + 1 lame | 12 |



**CUTTER PROFESIONAL**



| Nu.   | specificatie |    |
|-------|--------------|----|
| 16125 | L4 9 mm      | 24 |
| 16120 | L8 18 mm     | 24 |



**CUTTER PROFESIONAL**



| Nu.   | specificatie |    |
|-------|--------------|----|
| 16115 | L10 9 mm     | 24 |



**FESTA**  
CUTTER PROFESIONAL

**ALU**

| Nu.   | specificație               |    |
|-------|----------------------------|----|
| 16150 | 18 mm                      | 24 |
| 16151 | 18 mm fără imprimare FESTA | 20 |



**FESTA**  
CUTTER PROFESIONAL

**ALU**

| Nu.   | specificație |    |
|-------|--------------|----|
| 16136 | 18 mm        | 12 |



**FESTA**  
CUTTER PROFESIONAL

**ALU**

| Nu.   | specificație |    |
|-------|--------------|----|
| 16137 | 25 mm        | 12 |



**FESTA**  
CUTTER PROFESIONAL  
· Acoperire din cauciuc antiderapant

**+4 ALU**

| Nu.   | specificație |    |
|-------|--------------|----|
| 16090 | 18 mm        | 12 |



**FESTA**  
CUTTER PROFESIONAL  
· Acoperire din cauciuc antiderapant

**+4 ALU**

| Nu.   | specificație |   |
|-------|--------------|---|
| 16091 | 25 mm        | 6 |



**FESTA**  
CUTTER PROFESIONAL  
· Acoperire din cauciuc antiderapant

**ALU**

| Nu.   | specificație |    |
|-------|--------------|----|
| 16145 | L25 18 mm    | 12 |



**FESTA**  
CUTTER PROFESIONAL  
· Acoperire din cauciuc antiderapant

**ALU**

| Nu.   | specificație |    |
|-------|--------------|----|
| 16144 | L24 18 mm    | 12 |



**FESTA**  
CUTTER PROFESIONAL

**ALU**

| Nu.   | specificație |    |
|-------|--------------|----|
| 16143 | 18 mm        | 12 |



**FESTA**  
CUTTER PROFESIONAL

**ALU**

| Nu.   | specificație |    |
|-------|--------------|----|
| 16142 | 18 mm        | 12 |



**FESTA**  
CUTTER PROFESIONAL

**ALU**

| Nu.   | specificație |    |
|-------|--------------|----|
| 16025 | 18 mm        | 12 |



**FESTA**  
CUTTER PROFESIONAL

**ALU**

| Nu.   | specificație |    |
|-------|--------------|----|
| 16029 | 18 mm        | 25 |



**FESTA**  
CUTTER PROFESIONAL  
· Acoperire din cauciuc antiderapant

**ALU**

| Nu.   | specificație |    |
|-------|--------------|----|
| 16146 | 18 mm        | 12 |



**FESTA**

**CUTTER PROFESIONAL**

· Acoperire din cauciuc antiderapant



| Nu.   | specificatie |    |
|-------|--------------|----|
| 16147 | 25 mm        | 12 |



**FESTA**

**CUTTER PROFESIONAL**

· Acoperire din cauciuc antiderapant



| Nu.   | specificatie       |    |
|-------|--------------------|----|
| 16130 | L18 18 mm + 5 lame | 12 |



**FESTA**

**CUTTER PROFESIONAL**

· Acoperire din cauciuc antiderapant



| Nu.   | specificatie       |   |
|-------|--------------------|---|
| 16135 | L20 25 mm + 5 lame | 6 |



**FESTA**

**CUTTER PROFESIONAL**

· Acoperire din cauciuc antiderapant



| Nu.   | specificatie |    |
|-------|--------------|----|
| 16140 | L22 18 mm    | 12 |



**FESTA**

**CUTTER PROFESIONAL**

· Acoperire din cauciuc antiderapant



| Nu.   | specificatie |    |
|-------|--------------|----|
| 16034 | 25 mm        | 12 |



**FESTA**

**CUTTER PROFESIONAL**



| Nu.   | specificatie |    |
|-------|--------------|----|
| 16085 | 9 mm         | 24 |

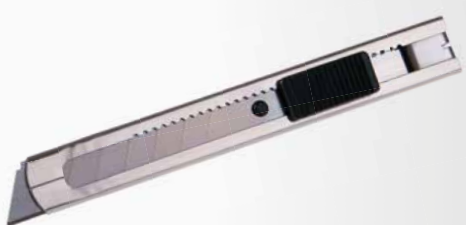

**FESTA**

**CUTTER PROFESIONAL**



| Nu.   | specificatie |    |
|-------|--------------|----|
| 16086 | 18 mm        | 24 |



**BRICEAG DE SIGURANȚĂ**

| Nu.   | specificatie |    |
|-------|--------------|----|
| 16044 |              | 20 |



**BRICEAG DE SIGURANȚĂ**

· lama cu bobina automata

| Nu.   | specificatie |    |
|-------|--------------|----|
| 16057 | 135 mm       | 12 |



**FESTA**

**BRICEAG DE SIGURANȚĂ**



| Nu.   | specificatie        |   |
|-------|---------------------|---|
| 16058 |                     | 6 |
| 16074 | lame rezerva 10 buc | 1 |

16074





**NEW**



**FESTO**

**CUTTER PROFESIONAL**

**+2 SK4**



| Nu.   | specificatie |   |
|-------|--------------|---|
| 16039 |              | 6 |
| 16087 | Lame rezerva | 1 |



**FESTO**

**CUTTER PROFESIONAL**

**+5 ALU**



| Nu.   | specificatie |   |
|-------|--------------|---|
| 16037 | + 5 lame     | 6 |

**FESTO**

**CUTTER PROFESIONAL**

**+5 ALU**



| Nu.   | specificatie        |    |
|-------|---------------------|----|
| 16023 | Cutter + 5 lame     | 12 |
| 16071 | Lame rezerva 10 buc | 10 |

**FESTO**

**CUTTERE TURBO**

**ALU**

| Nu.   | specificatie |   |
|-------|--------------|---|
| 16095 | 25 lamek     | 1 |



**SET BISTURIU**

**22x**



| Nu.   | specificatie |    |
|-------|--------------|----|
| 16282 |              | 24 |



**SET BISTURIU**

**13x**



| Nu.   | specificatie |    |
|-------|--------------|----|
| 16281 |              | 10 |



**FESTO**

**CUTTER**

Acoperire din cauciuc antiderapant

**ALU +2**



| Nu.   | specificatie |    |
|-------|--------------|----|
| 16035 | + 2 lame     | 12 |

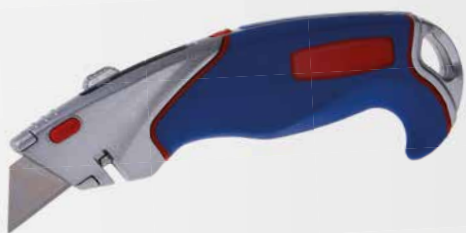

**FESTO**

**CUTTER**

**ALU +3**



| Nu.   | specificatie    |   |
|-------|-----------------|---|
| 16033 | NP 110 + 3 lame | 5 |





CUTTER

ALU



| Nu.   | specificatie |    |
|-------|--------------|----|
| 16032 | NP 109       | 48 |



CUTTER

ALU

| Nu.   | specificatie |    |
|-------|--------------|----|
| 16031 | NS 107 B     | 24 |



CUTTER

ALU

| Nu.   | specificatie |    |
|-------|--------------|----|
| 16030 | NS 107       | 24 |



CUTTER

ALU



| Nu.   | specificatie |    |
|-------|--------------|----|
| 16046 | 18 mm        | 12 |



CUTTER

| Nu.   | specificatie |    |
|-------|--------------|----|
| 16028 | S 201 18 mm  | 24 |



CUTTER

| Nu.   | specificatie |    |
|-------|--------------|----|
| 16026 | P 205 18 mm  | 30 |



CUTTER

HOBBY

| Nu.   | specificatie |    |
|-------|--------------|----|
| 16021 | P 201 9 mm   | 60 |



CUTTER

HOBBY

| Nu.   | specificatie |    |
|-------|--------------|----|
| 16024 | P 204 18 mm  | 60 |



CUTTER 24 BUC

MOQ 24

Acoperire din cauciuc antiderapant

| Nu.   | specificatie |    |
|-------|--------------|----|
| 16141 | 18 mm        | 24 |



CUTTERE

HOBBY 12x

| Nu.   | specificatie |    |
|-------|--------------|----|
| 16053 | 9 mm         | 12 |
| 16055 | 18 mm        | 12 |



CUTTERE

HOBBY 3x

| Nu.   | specificatie |    |
|-------|--------------|----|
| 16043 |              | 24 |





**CUTTER PENTRU MOCHETA**

· pentru covoare și podele



| Nu.   | specificație |    |
|-------|--------------|----|
| 16036 | 45 mm        | 12 |



**CUTTER**

· pentru covoare și podele



| Nu.   | specificație |    |
|-------|--------------|----|
| 16041 |              | 12 |



50 mm

**RACLETA LUNGA PENTRU FERESTRE**

**ALU**



| Nu.   | specificație |    |
|-------|--------------|----|
| 16059 | 50 mm        | 10 |
| 16082 | lame rezerva | 1  |



100 mm

**RACLETA LUNGA PENTRU FERESTRE**

· pentru utilizare cu lame de 18 mm pentru cuțite de rupere

**ALU**



| Nu.   | specificație |   |
|-------|--------------|---|
| 16054 | 100 mm       | 1 |



100 mm

**RACLETA LUNGA PENTRU FERESTRE**

| Nu.   | specificație  |    |
|-------|---------------|----|
| 16052 | 48 cm lungime | 6  |
| 16070 | lame          | 25 |



38 mm

**FESTA**

**RASCHETA FEREASTRA**

· Acoperire din cauciuc antiderapant



| Nu.   | specificație |    |
|-------|--------------|----|
| 16049 |              | 12 |
| 16069 | lame rezerva | 1  |



60 mm

**RASCHETA FEREASTRA**

| Nu.   | specificație |    |
|-------|--------------|----|
| 16051 |              | 24 |



55 mm

**RASCHETA FEREASTRA**

| Nu.   | specificație |    |
|-------|--------------|----|
| 16050 |              | 24 |



**SET DE RĂZUITOARE PENTRU APLICAREA ȘI ÎNDEPĂRTAREA SILICONULUI**

**3x**



| Nu.   | specificație |    |
|-------|--------------|----|
| 16042 |              | 12 |





**FESTA**  
LAME REZERVA

- 7 segmente
- 3x longer lifetime
- măcinare dublă
- rezistență redusă la tăiere



| Nu.   | specificație |    |
|-------|--------------|----|
| 16064 | 25   0,7 mm  | 20 |

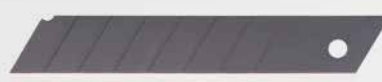

**FESTA**  
LAME REZERVA

- 8 segmente
- 3x longer lifetime
- măcinare dublă
- rezistență redusă la tăiere



| Nu.   | specificație |    |
|-------|--------------|----|
| 16062 | 18   0,7 mm  | 10 |



**FESTA**  
LAME REZERVA

- 15 segmente
- 3x longer lifetime
- măcinare dublă
- rezistență redusă la tăiere

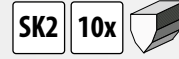

| Nu.   | specificație |    |
|-------|--------------|----|
| 16063 | 18   0,7 mm  | 10 |



**FESTA**  
REZERVNA KERAMIČKA  
OŠTRICA

- 8 segmente
- 3x sharper than the steel blade
- 10x longer lifetime
- Refractory, non-conductive, non-magnetic



| Nu.   | specificație |    |
|-------|--------------|----|
| 16066 | 18   0,6 mm  | 10 |



LAME REZERVA

- 8 segmente
- măcinare dublă



| Nu.   | specificație |    |
|-------|--------------|----|
| 16078 | 18   0,5 mm  | 25 |



LAME REZERVA

- 8 segmente
- măcinare dublă



| Nu.   | specificație |    |
|-------|--------------|----|
| 16077 | 18   0,6 mm  | 25 |



LAME REZERVA

- 7 segmente



| Nu.   | specificație |    |
|-------|--------------|----|
| 16068 | 25   0,6 mm  | 20 |



LAME REZERVA

- 8 segmente



| Nu.   | specificație |    |
|-------|--------------|----|
| 16065 | 18   0,5 mm  | 60 |



LAME REZERVA

- 15 segmente



| Nu.   | specificație |    |
|-------|--------------|----|
| 16081 | 18   0,5 mm  | 60 |



LAME REZERVA

- 4 segmente



| Nu.   | specificație |    |
|-------|--------------|----|
| 16067 | 18   0,5 mm  | 10 |



LAME REZERVA 30°

- 7 segmente



| Nu.   | specificație |    |
|-------|--------------|----|
| 16061 | 9   0,4 mm   | 60 |

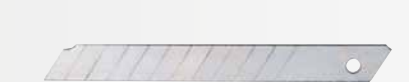

LAME REZERVA

- 13 segmente



| Nu.   | specificație |    |
|-------|--------------|----|
| 16060 | 9   0,45 mm  | 10 |



**FESTA**  
LAME REZERVA



| Nu.   | specificație |    |
|-------|--------------|----|
| 16072 | R 004        | 10 |



**FESTA**  
LAME REZERVA



| Nu.   | specificație |    |
|-------|--------------|----|
| 16075 | R 003        | 10 |



LAME REZERVA



| Nu.   | specificație |    |
|-------|--------------|----|
| 16071 | R 001        | 60 |

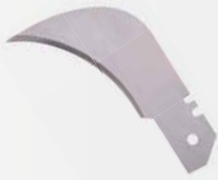

LAME REZERVA

5x

| Nu.   | specificație |    |
|-------|--------------|----|
| 16083 | 18 mm        | 50 |



LAME REZERVA

10x

| Nu.   | specificație |    |
|-------|--------------|----|
| 16073 | R 002        | 60 |



LAME REZERVA

5x

| Nu.   | specificație |    |
|-------|--------------|----|
| 16084 | 18 mm        | 50 |



**FESTA**

LAME REZERVA

· pentru 16058

10x

| Nu.   | specificație |   |
|-------|--------------|---|
| 16074 |              | 1 |



LAME REZERVA

· pentru 34315

| Nu.   | specificație |   |
|-------|--------------|---|
| 34316 |              | 1 |



LAME REZERVA

· pentru 16052

| Nu.   | specificație |    |
|-------|--------------|----|
| 16070 | 100 mm       | 25 |



**FESTA**

CUTTER PENTRU VATA

| Nu.   | specificație |    |
|-------|--------------|----|
| 16198 | 44,5   33 cm | 12 |

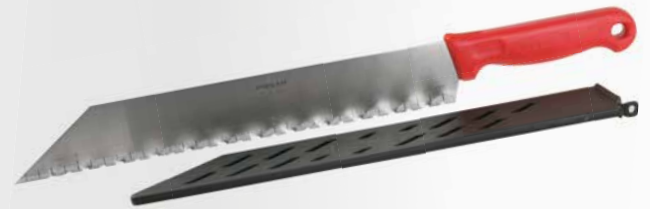

**FESTA**

CUTIT PENTRU IZOLATII

· pentru vata minerala, polistiren

| Nu.   | specificație |    |
|-------|--------------|----|
| 16199 | 48   35 cm   | 10 |



**FESTA**

MACETA

| Nu.   | specificație |   |
|-------|--------------|---|
| 45069 | 490 mm       | 6 |



**FESTA**

MACETA

| Nu.   | specificație |   |
|-------|--------------|---|
| 44950 | 490 mm       | 4 |



MACETA

| Nu.   | specificație |    |
|-------|--------------|----|
| 45083 | 430 mm       | 12 |
| 45084 | 600 mm       | 6  |



MACETA

· mâner realizat din lemn de frasin

| Nu.   | specificație |    |
|-------|--------------|----|
| 45081 | 510 mm       | 36 |
| 45082 | 710 mm       | 36 |



**FESTA**

**CUȚIT DE VÂNĂTOARE**

- nylon handle
- teflon coated blade
- case with fuse and clip



|             |               |              |       |              |    |
|-------------|---------------|--------------|-------|--------------|----|
| <b>INOX</b> | <b>TEFLON</b> | <b>NYLON</b> | Nu.   | specificație |    |
|             |               |              | 16234 | 21   10 cm   | 10 |



**FESTA**

**CUȚIT DE VÂNĂTOARE**



|             |               |       |              |    |
|-------------|---------------|-------|--------------|----|
| <b>INOX</b> | <b>TEFLON</b> | Nu.   | specificație |    |
|             |               | 16229 | 23   10 cm   | 12 |



**FESTA**

**MULTIFUNCTION CHISEL**

- îngroșată lama



MOQ  
12

|             |       |              |    |
|-------------|-------|--------------|----|
| <b>INOX</b> | Nu.   | specificație |    |
|             | 16231 | 20   8 cm    | 12 |



**CUTIT TEHNIC**

- îngroșată lama

|             |       |              |    |
|-------------|-------|--------------|----|
| <b>INOX</b> | Nu.   | specificație |    |
|             | 16230 | 21   10 cm   | 12 |



**FESTA**

**CUTTER PENTRU MOCHETE**

|       |              |    |
|-------|--------------|----|
| Nu.   | specificație |    |
| 16225 | 20   8,5 cm  | 12 |



**FESTA**

**BRICEAG**

- îngroșată lama

|             |       |              |    |
|-------------|-------|--------------|----|
| <b>INOX</b> | Nu.   | specificație |    |
|             | 16212 | 15   3,2 cm  | 12 |



**FESTA**

**BRICEAG**

|       |              |    |
|-------|--------------|----|
| Nu.   | specificație |    |
| 16201 | Ø 8 - 27 mm  | 10 |



**FESTA**

**BRICEAG**

|             |       |              |    |
|-------------|-------|--------------|----|
| <b>INOX</b> | Nu.   | specificație |    |
|             | 16211 | 20   8,5 cm  | 10 |



**FESTA**

**BRICEAG**

|             |       |              |    |
|-------------|-------|--------------|----|
| <b>INOX</b> | Nu.   | specificație |    |
|             | 16210 | 20,5   9 cm  | 10 |



**FESTA**  
BRICEAG



| INOX | Nu.   | specificatie | 24 |
|------|-------|--------------|----|
|      | 16219 | 19   11 cm   |    |



**FESTA**  
BRICEAG



| INOX | Nu.   | specificatie   | 24 |
|------|-------|----------------|----|
|      | 16218 | 18,5   10,5 cm |    |



**FESTA**  
BRICEAG



| INOX | Nu.   | specificatie | 24 |
|------|-------|--------------|----|
|      | 16220 | 18,5   11 cm |    |



**FESTA**  
BRICEAG



| INOX | Nu.   | specificatie  | 24 |
|------|-------|---------------|----|
|      | 16235 | 17,5   8,5 cm |    |



**FESTA**  
BRICEAG



| INOX | Nu.   | specificatie | 24 |
|------|-------|--------------|----|
|      | 16221 | 21   12 cm   |    |



**FESTA**  
BRICEAG



| INOX | Nu.   | specificatie | 24 |
|------|-------|--------------|----|
|      | 16236 | 22,5   10 cm |    |



**FESTA**  
BRICEAG



| INOX | Nu.   | specificatie  | 1 |
|------|-------|---------------|---|
|      | 16209 | 14,5   5,5 cm |   |



**FESTA**  
BRICEAG



| INOX | Nu.   | specificatie | 24 |
|------|-------|--------------|----|
|      | 16222 | 20   12 cm   |    |



**FESTA**  
BRICEAG



| INOX | ALU | Nu.   | specificatie   | 24 |
|------|-----|-------|----------------|----|
|      |     | 16223 | 18,5   10,5 cm |    |



**FESTA**

BRICEAG

· 5 funcție

|             |       |              |    |
|-------------|-------|--------------|----|
| <b>INOX</b> | Nu.   | specificație | 24 |
|             | 16228 | 27   10,5 cm |    |



**FESTA**

BRICEAG

· 10 funcție

|             |       |              |    |
|-------------|-------|--------------|----|
| <b>INOX</b> | Nu.   | specificație | 24 |
|             | 16226 | 17,5   7 cm  |    |



BRICEAG

· 7 funcție

|             |       |              |    |
|-------------|-------|--------------|----|
| <b>INOX</b> | Nu.   | specificație | 24 |
|             | 16224 | 17,5   7 cm  |    |



BRICEAG

· 3 funcție

|             |       |              |    |
|-------------|-------|--------------|----|
| <b>INOX</b> | Nu.   | specificație | 24 |
|             | 16227 | 20,5   10 cm |    |



**FESTA**

CLEȘTE MULTIFUNCȚIONALE

· 9 funcție

· Caz

|            |       |              |    |
|------------|-------|--------------|----|
| <b>CrV</b> | Nu.   | specificație | 12 |
|            | 16232 |              |    |



**FESTA**

CUTIT DE TRAS DREPT

|            |       |              |   |
|------------|-------|--------------|---|
| <b>CrV</b> | Nu.   | specificație | 1 |
|            | 24132 | 250/490 mm   |   |



RINDEA



|             |       |                                |   |
|-------------|-------|--------------------------------|---|
| <b>INOX</b> | Nu.   | specificație                   | 1 |
|             | 19510 | 220 x 65 x 130 mm, cuțit 48 mm |   |



RINDEA



|             |       |                                |   |
|-------------|-------|--------------------------------|---|
| <b>INOX</b> | Nu.   | specificație                   | 1 |
|             | 19515 | 200 x 55 x 130 mm, cuțit 39 mm |   |



RINDEA



|             |       |                                |   |
|-------------|-------|--------------------------------|---|
| <b>INOX</b> | Nu.   | specificație                   | 1 |
|             | 19520 | 225 x 27 x 155 mm, cuțit 27 mm |   |





**FESTA**

DALTI PENTRU LEMN

CrV

| Nu.   | specificație   |   |
|-------|----------------|---|
| 19490 | 6 mm   290 mm  | 6 |
| 19491 | 8 mm   290 mm  | 6 |
| 19492 | 10 mm   290 mm | 6 |
| 19493 | 12 mm   290 mm | 6 |
| 19494 | 14 mm   290 mm | 6 |
| 19495 | 16 mm   290 mm | 6 |

| Nu.   | specificație   |   |
|-------|----------------|---|
| 19496 | 18 mm   290 mm | 6 |
| 19497 | 20 mm   290 mm | 6 |
| 19498 | 22 mm   290 mm | 6 |
| 19499 | 25 mm   290 mm | 6 |
| 19501 | 32 mm   290 mm | 6 |
| 19502 | 38 mm   290 mm | 6 |



**FESTA**

DALTA MULTIFUNCȚIONALĂ

INOX

| Nu.   | specificație |    |
|-------|--------------|----|
| 16231 | 20   80 mm   | 12 |



MOQ 12



**FESTA**

SET DALTI PENTRU LEMN

CrV

5x

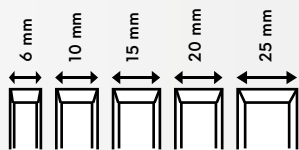

| Nu.   | specificație |    |
|-------|--------------|----|
| 19451 |              | 10 |



**FESTA**

SET DALTI PENTRU LEMN

CrV

4x

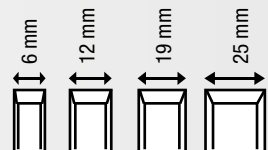

| Nu.   | specificație |    |
|-------|--------------|----|
| 19457 |              | 10 |



SET DALTI PENTRU LEMN

4x

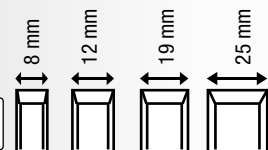

| Nu.   | specificație |    |
|-------|--------------|----|
| 19455 |              | 30 |

**FESTA**



**FESTA**

SET DALTI PENTRU LEMN

CrV

8x

| Nu.   | specificație |   |
|-------|--------------|---|
| 19458 | 365   125mm  | 1 |



SET DALTI PENTRU LEMN

4x

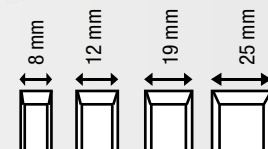

| Nu.   | specificație |    |
|-------|--------------|----|
| 19450 |              | 20 |



SET DALTI PENTRU LEMN

12x

CrV

| Nu.   | specificație |   |
|-------|--------------|---|
| 19459 |              | 5 |



**FESTA**

PIATRA DE ASCUTIT 16v1



|  |             |  |
|--|-------------|--|
|  | 30° Anvil   |  |
|  | 45° Anvil   |  |
|  | 50° Anvil   |  |
|  | 23° Bypass  |  |
|  | 35° Bypass  |  |
|  | 65° Bypass  |  |
|  | Deburr Tool |  |



Nu. specificație

45073



1



PIATRA ASCUTIT ROTUNDA

Nu. specificație

45370

250 x 33 x 18 mm



20

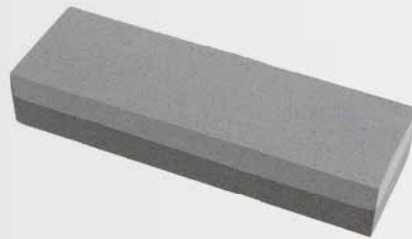

PIATRA ASCUTIT

Nu. specificație

45045

150 x 50 x 30 mm



1



PIATRA DE ASCUTIT

Nu. specificație

45046

205 x 15 mm



100



UNEALTA ACTUTIT FOARFECI SI CUTITE

Nu. specificație

16991

20



20



UNEALTA ACTUTIT FOARFECI SI CUTITE

Nu. specificație

16990

Ø 50 mm



1



UNEALTA ASCUTIT FOARFECI SI CUTITE

Nu. specificație

45048

20



20



UNEALTA ACTUTIT FOARFECI SI CUTITE 6IN 1

Nu. specificație

45068

10



10



WINLAND



WINLAND



**FESTA**  
POWER X TOOLS

PIPE WELDER

- voltage / frequency 230 V / 50 Hz
- power consumption 750 / 1500 W
- temperature 0-300 C°
- extensions Ø 20,25,32,40,50,63 mm
- weight 1,6 kg



· package included: measuring tape, spirit level, screwdriver, hex key, 6x welding adapter, stand, shelf case



| Nu.   | specificatie | 1 |
|-------|--------------|---|
| 17182 |              | 1 |

**FESTA**  
POWER X TOOLS

PIPE WELDER

- voltage / frequency 230 V / 50 Hz
- power consumption 800 / 1000 W
- temperature 0-300 C°
- extensions Ø 16, 20, 25, 32 mm
- weight 1 kg



· package included: hex key, 4x welding adapter, stand, shelf case



| Nu.   | specificatie | 1 |
|-------|--------------|---|
| 17183 |              | 1 |

**FESTA**

DISPOZITIV  
PENTRU TAIAT TEVI

max.  
42 mm



| Nu.   | specificatie | 10 |
|-------|--------------|----|
| 17027 |              | 10 |
| 16315 | lamă rezerva | 1  |

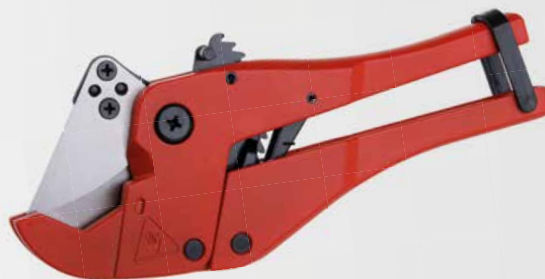

LAME DE SCHIMB

· pentru 17027

| Nu.   | specificatie | 1 |
|-------|--------------|---|
| 16315 |              | 1 |



**FESTA**



**FESTA**

DISPOZITIV PENTRU  
TAIAT TEVI

max.  
32 mm



| Nu.   | specificatie | 12 |
|-------|--------------|----|
| 17037 |              | 12 |



DISPOZITIV PENTRU TAIAT TEVI

max.  
42 mm



| Nu.   | specificatie | 6 |
|-------|--------------|---|
| 17026 |              | 6 |



NEW

**FESTA**

DISPOZITIV PENTRU TAIAT TEVI

INOX ALU

ALU Cu PVC



| Nu.   | specificatie |    |
|-------|--------------|----|
| 16305 | Ø 22 mm      | 10 |
| 16306 | Ø 15 mm      | 10 |
| 16307 | NEW Ø 28 mm  | 10 |



NEW

**FESTA**

DISPOZITIV PENTRU TAIAT TEVI

PLASTIC INOX

PVC

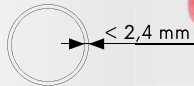

| Nu.   | specificatie |    |
|-------|--------------|----|
| 16308 | Ø 20 - 50 mm | 10 |

**FESTA**

DISPOZITIV PENTRU TAIAT TEVI

Ø 15 mm  
Ø 22 mm  
Ø 28 mm

3x INOX ALU

ALU Cu PVC



| Nu.   | specificatie |   |
|-------|--------------|---|
| 16309 |              | 1 |



**FESTA**

DISPOZITIV PENTRU  
TAIAT TEVI



3-22  
mm



| Nu.   | specificație    |    |
|-------|-----------------|----|
| 16301 |                 | 10 |
| 16311 | Lama de rezervă | 1  |

**FESTA**

DISPOZITIV  
PENTRU  
TAIAT TEVI



6-64  
mm



| Nu.   | specificație    |   |
|-------|-----------------|---|
| 16304 |                 | 6 |
| 16312 | Lama de rezervă | 1 |

DISPOZITIV  
PENTRU  
TAIAT TEVI



3-32  
mm



| Nu.   | specificație    |    |
|-------|-----------------|----|
| 16303 |                 | 10 |
| 16311 | Lama de rezervă | 1  |

DISPOZITIV  
PENTRU  
TAIAT TEVI



3-32  
mm



| Nu.   | specificație    |    |
|-------|-----------------|----|
| 16300 |                 | 10 |
| 16310 | Lama de rezervă | 1  |

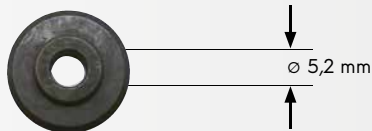

ROTI DE TĂIERE TEVI



| Nu.   | specificație                           |   |
|-------|--|---|
| 16310 | Ø 17,5 mm x 6 m pentru 16300           | 1 |
| 16311 | Ø 18,0 mm x 4,5 mm pentru 16303, 16301 | 1 |
| 16312 | Ø 27,5 mm x 6 mm pentru 16304          | 1 |



**FESTA**

FOARFECA  
PENTRU PROFILE

plinte, profile, tevi

5x Ø 17 mm Ø 20 mm Ø 27 mm

| Nu.   | specificație |   |
|-------|--------------|---|
| 17050 | 60   250 mm  | 8 |



NEW

**FESTA**

SLEFUIITOR  
MUCHII  
PLASTIC



6-38  
mm ALU



| Nu.   | specificație |   |
|-------|--------------|---|
| 16319 | Ø 6 - 38 mm  | 1 |

**FESTA**

ÎNDEPĂRTARE  
BAVURĂ



1/4"

| Nu.   | specificație |   |
|-------|--------------|---|
| 16321 |              | 1 |

SLEFUIITOR  
MUCHII  
PLASTIC



6-32  
mm



| Nu.   | specificație |   |
|-------|--------------|---|
| 16320 |              | 1 |

**FESTA**

SET FREZE



HSS Ø 25 mm 90°



| Nu.   | specificație |    |
|-------|--------------|----|
| 20360 |              | 10 |

DISPOZITIV  
ÎNDEPĂRTARE  
BAVURĂ



| Nu.   | specificație |   |
|-------|--------------|---|
| 20361 |              | 1 |



SURUBELNITE



| Nu.   | specificatie |    |
|-------|--------------|----|
| 18113 | 3 x 75 mm    | 12 |
| 18114 | 4 x 100mm    | 12 |
| 18115 | 5,5 x 125 mm | 12 |
| 18116 | 6,5 x 150 mm | 12 |
| 18118 | 8 x 175 mm   | 6  |
| 18120 | 10 x 200 mm  | 6  |



PHILIPS SURUBELNITE

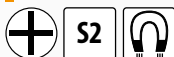

| Nu.   | specificatie |    |
|-------|--------------|----|
| 18210 | 0 x 75 mm    | 12 |
| 18211 | 1 x 75 mm    | 12 |
| 18212 | 2 x 100 mm   | 12 |



POZIDRIVE SURUBELNITE



| Nu.   | specificatie |    |
|-------|--------------|----|
| 18310 | 0 x 75 mm    | 12 |
| 18311 | 1 x 100 mm   | 12 |
| 18312 | 2 x 100 mm   | 12 |
| 18313 | 3 x 150 mm   | 6  |



TORX SURUBELNITE



| Nu.   | specificatie |    |
|-------|--------------|----|
| 18350 | T6           | 12 |
| 18351 | T7           | 12 |
| 18352 | T8           | 12 |
| 18353 | T9           | 12 |
| 18354 | T10          | 12 |
| 18355 | T15          | 12 |
| 18356 | T20          | 12 |
| 18357 | T25          | 12 |
| 18358 | T27          | 12 |
| 18359 | T30          | 12 |
| 18360 | T40          | 6  |



SURUBELNITE SCURTE

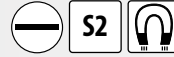

| Nu.   | specificatie |    |
|-------|--------------|----|
| 18124 | 5,5 x 38 mm  | 12 |
| 18125 | 6,5 x 38 mm  | 12 |



PHILIPS SURUBELNITE SCURTE

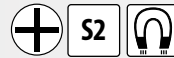

| Nu.   | specificatie |    |
|-------|--------------|----|
| 18215 | 1 x 38 mm    | 12 |
| 18216 | 2 x 38 mm    | 12 |



POZIDRIVE SURUBELNITE SCURTE

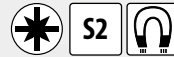

| Nu.   | specificatie |    |
|-------|--------------|----|
| 18321 | 1 x 38 mm    | 12 |
| 18322 | 2 x 38 mm    | 12 |



SURUBELNITE + 7 BITURI



- ⊖ S 5 · 6 mm
- ⊕ PH 1 · 2 · 3
- ⊗ T 15 · 20

| Nu.   | specificatie |    |
|-------|--------------|----|
| 18425 |              | 10 |



SURUBELNITE ȘI SETUL DE BIȚI

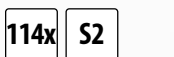

| Nu.   | specificatie |   |
|-------|--------------|---|
| 18434 |              | 1 |

- surubelnita pentru bituri
- surubelnita de precizie pentru bituri
- surubelnite
  - ⊖ 3x75, 5x75, 5x100, 6x100, 6x150, 8x150
  - ⊕ 0x75, 1x75, 1x100, 2x100, 2x150
  - ⊗ T10x75, T15x75
  - ⊖ VDE 2.5x75mm, 4.0x100mm
  - ⊖ surubelnita tester
  - ⊖ 2.5x40, 3.0x40mm
  - ⊕ 00x40mm, 0x40mm,
  - ⊗ T6x40mm, T7x40mm
- inbus
  - 1/16", 5/64", 3/32", 1/8", 5/32", 3/16", 7/32", 1/4"
  - 1.5, 2.0, 2.5, 3.0, 4.0, 5.0, 5.5, 6.0mm
- chei tubulare
  - 6mm, 7mm, 8mm, 9mm, 10mm, 11mm
- bituri
  - ⊖ SL 3mm, 4mm, 4.5mm, 5mm, 5.5mm, 6mm, 7mm, 8mm
  - ⊕ PH0, PH0, PH1, PH1, PH2, PH2, PH3, PH3
  - ⊗ PZ0, PZ0, PZ1, PZ1, PZ2, PZ2, PZ3, PZ3,
  - ⊗ T6, T8, T10, T15, T20, T25, T27, T30, T35, T40
  - H1.5, H2.5, H3.0, H3.5, H4.0, H4.5, H5.0, H5.5, H6, H8
  - ⊖ S0, S1, S2, S3
- precizie bituri
  - ⊖ SL 1.5mm, 2.0mm, 2.5mm, 3.0mm, 4.0mm
  - ⊕ PH000, PH00, PH0, PH1
  - ⊗ T4, T5, T6, T7, T8, T9, T10, T15, T20
  - H0.7, H0.9



**SURUBELNITE SET**

⊖ S 3x75 · 5x100 · 6,5x150mm

⊕ PH 0 · 1 · 2 · 3



7x



Nu. specificație

18402

6



**SURUBELNITE SET**

⊖ S 3x75 · 5x100 · 6x150mm

⊕ PH 0 · 1 · 2



6x



Nu. specificație

18403

6



**SURUBELNITE SET**

⊖ S 6,5x38 · 5,5x75 · 6,5x100 · 8x150 mm  
2,5x50 · 3x50 mm

⊕ PH 2x38 · 1x75 · 2x100 · 3x150 mm  
0x50 · 00x50 mm

⊛ T 5x50 · 6x50 · 7x50 · 8x50 · 9x50 · 10x50 mm



18x



Nu. specificație

18424

6



**SURUBELNITE SET**

⊖ S 3x75 · 5x100 · 6,5x150 mm

⊛ PZ 0 · 1 · 2



6x



Nu. specificație

18404

6



**TORX SURUBELNITE SET**

⊛ T 10 · 15 · 20 · 25 · 30



5x



Nu. specificație

18340

6



**SURUBELNITE SET**

⊖ S 3 x 75 · 4x100 · 5,5x125 · 6,5 x 150mm

⊕ PH1 x 100 · 2 x 100mm

⊖ adapter 1/4"

bity | bits: ⊖ S 4 · 5 · 6 · 7

⊕ PH1 · 2 · 3

⊛ PZ1 · 2 · 3

⊛ T10 · 15 · 20 · 25 · 30

⊖ H 2 · 3 · 4 · 5 · 6



27x



Nu. specificație

18422

27 buc

6



**FESTA**  
INDUSTRY

VDE SURUBELNITE



| Nu.   | specificatie |     |    |
|-------|--------------|-----|----|
| 18088 | 3 x 75 mm    | S2  | 12 |
| 18089 | 4 x 100 mm   | CrV | 12 |
| 18090 | 5,5 x 125 mm | CrV | 12 |
| 18091 | 6,5 x 150 mm | CrV | 12 |
| 18092 | 8 x 175 mm   | CrV | 12 |



**FESTA**  
INDUSTRY

PHILIPS VDE SURUBELNITE



| Nu.   | specificatie  |     |    |
|-------|---------------|-----|----|
| 18080 | PH 0 x 60 mm  | S2  | 12 |
| 18081 | PH 1 x 80 mm  | CrV | 12 |
| 18082 | PH 2 x 100 mm | CrV | 12 |
| 18083 | PH 3 x 150 mm | CrV | 12 |



**FESTA**  
INDUSTRY

SET SURUBELNITE ELECTRICIAN

⊖ S 4x100 · 5,5x125 mm · surubelnita tester 0 - 250 V  
⊕ PH 0x60 · 1x80 · 2x100 mm



| Nu.   | specificatie |   |
|-------|--------------|---|
| 18413 |              | 6 |



**FESTA**  
INDUSTRY

POZIDRIVE VDE SURUBELNITE



| Nu.   | specificatie  |     |    |
|-------|---------------|-----|----|
| 18084 | PZ 0 x 60 mm  | S2  | 12 |
| 18085 | PZ 1 x 80 mm  | CrV | 12 |
| 18086 | PZ 2 x 100 mm | CrV | 12 |
| 18087 | PZ 3 x 150 mm | CrV | 12 |



**FESTA**

IMPACT SURUBELNITE



| Nu.   | specificatie |  |    |
|-------|--------------|--|----|
| 18062 | 5,5 x 100 mm |  | 12 |
| 18063 | 7 x 125 mm   |  | 6  |
| 18064 | 8 x 150 mm   |  | 8  |
| 18065 | 10 x 175 mm  |  | 6  |
| 18066 | 10 x 200 mm  |  | 6  |
| 18067 | 10 x 250 mm  |  | 6  |



**FESTA**

PHILIPS IMPACT SURUBELNITE



| Nu.   | specificatie  |  |    |
|-------|---------------|--|----|
| 18070 | PH 1 x 80 mm  |  | 8  |
| 18071 | PH 2 x 100 mm |  | 12 |
| 18072 | PH 3 x 150 mm |  | 6  |



**FESTA**

SET SURUBELNITE ELECTRICIAN

⊖ S 4x100 · 5,5x125 · 6,5x150 mm · surubelnita tester 0 - 250 V  
⊕ PH 0x75 · 1x100 · 2x100 mm



| Nu.   | specificatie |    |
|-------|--------------|----|
| 18410 |              | 40 |



**FESTA**

POZIDRIVE IMPACT SURUBELNITE



| Nu.   | specificatie  |  |    |
|-------|---------------|--|----|
| 18075 | PZ 1 x 80 mm  |  | 12 |
| 18076 | PZ 2 x 100 mm |  | 12 |
| 18077 | PZ 3 x 150 mm |  | 6  |



**FESTA**

SURUBELNITE + 6 BITS

⊖ S 7 x 35 · 8 x 35 · 8 x 70 mm  
⊕ PH 2 x 35 · 3 x 35 · 3 x 70 mm

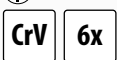

| Nu.   | specificatie |   |
|-------|--------------|---|
| 18411 |              | 1 |



**FESTA**

SURUBELNITE SET

⊖ S 5 · 6 · 8 mm  
⊕ PH 1 · 2 · 3

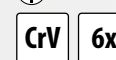

| Nu.   | specificatie |    |
|-------|--------------|----|
| 18423 |              | 10 |

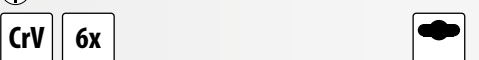





**FESTA**

**SURUBELNITE ȘI SETUL DE BIȚI**

⊖ S 3x75 · 4x75 · 6x100 · 8x150 mm

⊕ PH 1x75 · 2x100 mm

○ adapter 1/4"

bits: ⊖ S 4 · 5 · 6 · 7 mm

⊕ PH 1 · 2 · 3

⊗ PZ 1 · 2 · 3

⊛ T 10 · 15 · 20

○ ↔ ⊠ adapter



| Nu.   | specificație |    |
|-------|--------------|----|
| 18418 |              | 10 |



**FESTA**

**PHILIPS SURUBELNITE**

⊖ S 3x60 · 4x75 · 6x100 · 6x125 mm

⊕ PH 0x60 · 1x75 · 2x100 mm



| Nu.   | specificație |    |
|-------|--------------|----|
| 18400 |              | 10 |



**FESTA**

**PHILIPS SURUBELNITE**

⊖ S 3x60 · 6x100 · 6x125 mm

⊕ PH 1x75 · 2x100 mm



| Nu.   | specificație |   |
|-------|--------------|---|
| 18401 |              | 1 |

**FESTA**

**SURUBELNITE**



| Nu.   | specificație |    |
|-------|--------------|----|
| 18101 | 3 x 75 mm    | 10 |
| 18102 | 4 x 100 mm   | 10 |
| 18103 | 5,5 x 100 mm | 10 |
| 18104 | 5,5 x 125 mm | 10 |
| 18105 | 6,5 x 100 mm | 10 |
| 18106 | 6,5 x 125 mm | 10 |
| 18107 | 8 x 160 mm   | 10 |
| 18108 | 10 x 160 mm  | 10 |

**FESTA**

**PHILIPS SURUBELNITE**



| Nu.   | specificație |    |
|-------|--------------|----|
| 18201 | 0 x 75 mm    | 10 |
| 18202 | 1 x 75 mm    | 10 |
| 18203 | 2 x 100 mm   | 10 |
| 18204 | 3 x 150 mm   | 10 |

**FESTA**

**POZIDRIVE SURUBELNITE**



| Nu.   | specificație |    |
|-------|--------------|----|
| 18301 | 0 x 75 mm    | 10 |
| 18302 | 1 x 75 mm    | 10 |
| 18303 | 2 x 100 mm   | 10 |
| 18304 | 3 x 150 mm   | 10 |

**FESTA**

**SURUBELNITA CU ADAPTOR MAGNETIC PENTRU BITURI**



| Nu.   | specificație |    |
|-------|--------------|----|
| 18110 |              | 12 |



**FESTA**

**SURUBELNITA CU CHEIE**

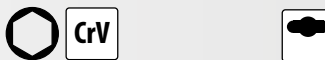

| Nu.   | specificație |    |
|-------|--------------|----|
| 18455 | 6 mm         | 12 |
| 18456 | 7 mm         | 12 |
| 18460 | 13 mm        | 12 |



**FESTA**

**SURUBELNITA FLEXIBILA PENTRU COLIERE**

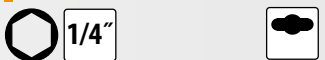

| Nu.   | specificație |    |
|-------|--------------|----|
| 18451 |              | 12 |



**FESTA**

**SURUBELNITA FLEXIBILA PENTRU COLIERE**

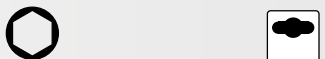

| Nu.   | specificație |   |
|-------|--------------|---|
| 18450 | 7 mm         | 6 |





**SURUBELNITE CU CLICHET**

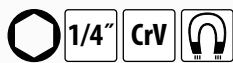

Nu. 18433 specificatie 6



**SURUBELNITA T CU ADAPTOR MAGNETIC PENTRU BITURI**

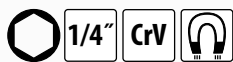

Nu. 18608 specificatie 6



**SET SURUBELNITA T + 20 BITURI**

- ⊖ S 3 · 4 · 5 · 6 · 8 mm
- ⊕ PH 0 · 1 · 2 · 3
- adapter + 5 · 6 · 7 · 8 · 9 · 10 · 11 · 12 · 13 mm



Nu. 18420 specificatie 5



**SET BITURI DE PRECIZIE CU ADAPTOR**

- ⊖ S 1.5 · 2 · 2.5 · 3 · 3.5 mm
- ⊕ PH 000 · 00 · 0 · 1
- ⊛ PZ 0 · 1
- ⊛ T 5 · 6 · 7 · 8 · 9 · 10 · 15 · 20
- ⊛ H 0.9 · 1.3 · 2.0 · 2.5 · 3.0 · 4.0



Nu. 18431 specificatie 6



**SURUBELNITE + BITURI**

- 1/4" ⊖ ↔ ⊕ 1/4"
- ⊖ S 3 · 4 · 5 · 6 · 7 · 5 L
- ⊕ PH 1 · 2 · 3 · 1L · 2L
- ⊛ PZ 1 · 2 · 3 · 1L · 2L
- ⊛ H 2 · 2.5 · 3 · 4 · 5 · 6
- ⊛ T 10 · 15 · 20 · 25 · 27 · 30
- ⊛ SQ 0 · 1 · 2 · 3
- 1/4" 5 · 6 · 7 · 8 · 9 · 10 · 11 · 12 · 13 mm



Nu. 18419 specificatie 6



**SET SURUBELNITE DE PRECIZIE**

- ⊖ S 1,5x50 · 2x50 · 2,5x50 mm
- ⊕ PH 000x50 · 00x50 · 0x50 mm



Nu. 18416 specificatie 6



**SET SURUBELNITE DE PRECIZIE TORX**

- ⊛ T 4 · 5 · 6 · 7 · 8 · 9 · 10x50 mm



Nu. 18417 specificatie 6



**SET SURUBELNITE ELECTRICIAN**

- ⊖ S 2,4 · 3,0 mm
- ⊕ PH 0 · 1
- ⊛ T 6 · 8



Nu. 18415 specificatie 10

**FESTA**



**NEW**



**FESTA**

**SURUBELNITA TESTER**

· AC - 110 V, 250 V



Nu.      specificație  
**18427**

**24**

**SURUBELNITA TESTER**

DIN VDE 0680  
73/23 EEC



Nu.      specificație  
**18426**      0 - 250 V

**1**

**FESTA**

**DESCHIZATOR DE STICLE**

Nu.      specificație  
**18437**



**5**

**SET SURUBELNITE DE PRECIZIE**

⊖ S 1,4 · 2,0 · 2,4 · 3,0 mm

⊕ PH 0 · 1



**6x** **HOBBY**

Nu.      specificație  
**18408**



**10**



**ADAPTOR UNGHI PENTRU 90°**



Nu.      specificație  
**18910**



**25**



**RATCHET PENTRU BIȚI**



Nu.      specificație  
**18435**      93 mm



**1**



**SET SURUBELNITE DE PRECIZIE**

⊖ S 1,0 · 1,2 · 1,4 · 1,8 · 2,4 · 3,0 mm

⊕ PH 00 · 0 · 1

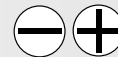

**11x** **HOBBY**

Nu.      specificație  
**18409**



**48**





BIT DE TORSIUNE PH - 50 MM



| Nu.   | specificatie |   |
|-------|--------------|---|
| 18715 | PH1 x 50 mm  | 1 |
| 18716 | PH2 x 50 mm  | 1 |
| 18717 | PH3 x 50 mm  | 1 |



BIT DE TORSIUNE PZ - 50 MM



| Nu.   | specificatie |   |
|-------|--------------|---|
| 18710 | PZ1 x 50 mm  | 1 |
| 18711 | PZ2 x 50 mm  | 1 |
| 18712 | PZ3 x 50 mm  | 1 |



BIT DE TORSIUNE T - 50 MM

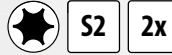

| Nu.   | specificatie |   |
|-------|--------------|---|
| 18720 | T10 x 50 mm  | 1 |
| 18721 | T15 x 50 mm  | 1 |
| 18722 | T20 x 50 mm  | 1 |
| 18723 | T25 x 50 mm  | 1 |
| 18724 | T30 x 50 mm  | 1 |
| 18725 | T40 x 50 mm  | 1 |



BIT DE TORSIUNE

- PH 2 · 2
- PZ 2
- T 15 · 15 · 20 · 20 · 25 · 30 · 40

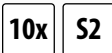

| Nu.   | specificatie |   |
|-------|--------------|---|
| 18432 |              | 1 |

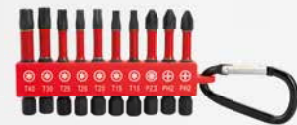

Bituri- profesionale de inalta calitate, material CrV S2

Atasamente forjate

crucea si corpul bitului, sunt facute conform unei tehnologii speciale de forjare exacta. Aceasta permite atingerea unui inalt nivel de acuratete in privinta formei, o data cu cresterea duritatii in comparatie cu bitii cu 20%.

strat TiN

acoperire dubla aplicata pe suprafata bitilor, creste maxim duritatea, rezistenta la frecare previne alunecarea din cupla. Este testat la corziune.

Granule de diamante

on the surface of the spike they really "bite" into the head of the wood screw or screw and enable to transfer maximum tightening torque. They are the best guarantee for staying in the meshing.

Caneluri antialunecare

pe suprafetele de lucru ale crampoanelor de insurubat facute prin forjare se afla caneluri de protectie eficienta contra alunecarii din angrenaj



**FESTA**  
INDUSTRY

**BIT PH**

**2x**

| Nu.    | specificație |   |
|--------|--------------|---|
| 18632A | PH2 x 25 mm  | 1 |
| 18633A | PH3 x 25 mm  | 1 |

**FESTA**  
INDUSTRY

**BIT PZ**

**2x** **S2**

| Nu.    | specificație |   |
|--------|--------------|---|
| 18636A | PZ1 x 25 mm  | 1 |
| 18637A | PZ2 x 25 mm  | 1 |
| 18638A | PZ3 x 25 mm  | 1 |

**FESTA**  
INDUSTRY

**BIT T**

**2x** **S2**

| Nu.    | specificație |   |
|--------|--------------|---|
| 18827A | T20 x 25 mm  | 1 |
| 18828A | T25 x 25 mm  | 1 |
| 18830A | T30 x 25 mm  | 1 |
| 18831A | T40 x 25 mm  | 1 |

**FESTA**  
INDUSTRY

**BIT PH DIAMANT**

**S2** **TiN** **DIN 3128**

**MOQ 5**

| Nu.   | specificație |   |
|-------|--------------|---|
| 18770 | PH1 x 25 mm  | 5 |
| 18771 | PH2 x 25 mm  | 5 |
| 18772 | PH3 x 25 mm  | 5 |

**FESTA**  
INDUSTRY

**BIT PZ DIAMANT**

**S2** **TiN** **DIN 3128**

**MOQ 5**

| Nu.   | specificație |   |
|-------|--------------|---|
| 18775 | PZ1 x 25 mm  | 5 |
| 18776 | PZ2 x 25 mm  | 5 |
| 18777 | PZ3 x 25 mm  | 5 |

**FESTA**  
INDUSTRY

**BIT S**

**S2**

**MOQ 5**

| Nu.   | specificație |   |
|-------|--------------|---|
| 18620 | S 3 x 25 mm  | 5 |
| 18621 | S 4 x 25 mm  | 5 |
| 18623 | S 5 x 25 mm  | 5 |
| 18625 | S 6 x 25 mm  | 5 |
| 18627 | S 7 x 25 mm  | 5 |
| 18628 | S 8 x 25 mm  | 5 |

**FESTA**  
INDUSTRY

**BIT PH**

**S2**

**MOQ 5**

| Nu.   | specificație |   |
|-------|--------------|---|
| 18630 | PH0 x 25 mm  | 5 |
| 18631 | PH1 x 25 mm  | 5 |
| 18632 | PH2 x 25 mm  | 5 |
| 18633 | PH3 x 25 mm  | 5 |
| 18634 | PH4 x 25 mm  | 5 |

**FESTA**  
INDUSTRY

**BIT PZ**

**S2**

**MOQ 5**

| Nu.   | specificație |   |
|-------|--------------|---|
| 18635 | PZ0 x 25 mm  | 5 |
| 18636 | PZ1 x 25 mm  | 5 |
| 18637 | PZ2 x 25 mm  | 5 |
| 18638 | PZ3 x 25 mm  | 5 |
| 18639 | PZ4 x 25 mm  | 5 |

**FESTA**  
INDUSTRY

**BIT PH**

**S2**

**MOQ 25**

| Nu.   | specificație |    |
|-------|--------------|----|
| 18685 | PH2 x 25 mm  | 25 |

**FESTA**  
INDUSTRY

**BIT PZ**

**S2**

**MOQ 25**

| Nu.   | specificație |    |
|-------|--------------|----|
| 18680 | PZ2 x 25 mm  | 25 |

**FESTA**  
INDUSTRY

**BIT PH**

**S2**

**MOQ 10**

| Nu.   | specificație |    |
|-------|--------------|----|
| 18640 | PH1 x 70 mm  | 10 |
| 18641 | PH2 x 70 mm  | 10 |

**FESTA**  
INDUSTRY

**BIT PZ**

**S2**

**MOQ 10**

| Nu.   | specificație |    |
|-------|--------------|----|
| 18645 | PZ1 x 70 mm  | 10 |
| 18646 | PZ2 x 70 mm  | 10 |

**FESTA**  
INDUSTRY

**BIT PH**

**S2** **TiN**

**MOQ 5**

| Nu.   | specificație |   |
|-------|--------------|---|
| 18760 | PH0 x 25 mm  | 5 |
| 18761 | PH1 x 25 mm  | 5 |
| 18762 | PH2 x 25 mm  | 5 |
| 18763 | PH3 x 25 mm  | 5 |
| 18764 | PH4 x 25 mm  | 1 |

**FESTA**  
INDUSTRY

**BIT PZ**

**S2** **TiN**

**MOQ 5**

| Nu.   | specificație |   |
|-------|--------------|---|
| 18765 | PZ0 x 25 mm  | 5 |
| 18766 | PZ1 x 25 mm  | 5 |
| 18767 | PZ2 x 25 mm  | 5 |
| 18768 | PZ3 x 25 mm  | 5 |
| 18769 | PZ4 x 25 mm  | 5 |

**FESTA**  
INDUSTRY

**BIT S**

**S2** **TiN**

**MOQ 5**

| Nu.   | specificație |   |
|-------|--------------|---|
| 18750 | S 3 x 25 mm  | 5 |
| 18751 | S 4 x 25 mm  | 5 |
| 18753 | S 5 x 25 mm  | 5 |
| 18755 | S 6 x 25 mm  | 5 |



BIT H



MOQ 5

| Nu.   | specificatie  |   |
|-------|---------------|---|
| 18800 | H 1,5 x 25 mm | 5 |
| 18801 | H 2,0 x 25 mm | 5 |
| 18802 | H 2,5 x 25 mm | 5 |
| 18803 | H 3,0 x 25 mm | 5 |
| 18804 | H 4,0 x 25 mm | 5 |
| 18805 | H 5,0 x 25 mm | 5 |
| 18806 | H 5,5 x 25 mm | 5 |
| 18807 | H 6,0 x 25 mm | 5 |



BIT TTA



MOQ 5

| Nu.   | specificatie   |    |
|-------|----------------|----|
| 18835 | TTa 5 x 25 mm  | 10 |
| 18836 | TTa 6 x 25 mm  | 5  |
| 18837 | TTa 7 x 25 mm  | 5  |
| 18838 | TTa 8 x 25 mm  | 5  |
| 18839 | TTa 9 x 25 mm  | 5  |
| 18840 | TTa 10 x 25 mm | 5  |
| 18841 | TTa 15 x 25 mm | 5  |
| 18842 | TTa 20 x 25 mm | 5  |
| 18843 | TTa 25 x 25 mm | 5  |
| 18844 | TTa 27 x 25 mm | 5  |
| 18845 | TTa 30 x 25 mm | 5  |
| 18846 | TTa 40 x 25 mm | 5  |
| 18847 | TTa 45 x 25 mm | 5  |



BIT T



MOQ 5

| Nu.   | specificatie |   |
|-------|--------------|---|
| 18820 | T5 x 25 mm   | 5 |
| 18821 | T6 x 25 mm   | 5 |
| 18822 | T7 x 25 mm   | 5 |
| 18823 | T8 x 25 mm   | 5 |
| 18824 | T9 x 25 mm   | 5 |
| 18825 | T10 x 25 mm  | 5 |
| 18826 | T15 x 25 mm  | 5 |
| 18827 | T20 x 25 mm  | 5 |
| 18828 | T25 x 25 mm  | 5 |
| 18829 | T27 x 25 mm  | 5 |
| 18830 | T30 x 25 mm  | 5 |
| 18831 | T40 x 25 mm  | 5 |
| 18832 | T45 x 25 mm  | 5 |



BIT HTA



MOQ 5

| Nu.   | specificatie    |   |
|-------|-----------------|---|
| 18810 | HTa 1,5 x 25 mm | 5 |
| 18811 | HTa 2,0 x 25 mm | 5 |
| 18812 | HTa 2,5 x 25 mm | 5 |
| 18813 | HTa 3,0 x 25 mm | 5 |
| 18814 | HTa 4,0 x 25 mm | 5 |
| 18815 | HTa 5,0 x 25 mm | 5 |
| 18816 | HTa 5,5 x 25 mm | 5 |
| 18817 | HTa 6,0 x 25 mm | 5 |



BIT SQ



MOQ 5

| Nu.   | specificatie |   |
|-------|--------------|---|
| 18850 | SQ 0 x 25 mm | 5 |
| 18851 | SQ 1 x 25 mm | 5 |
| 18852 | SQ 2 x 25 mm | 5 |
| 18853 | SQ 3 x 25 mm | 5 |



BIT T



MOQ 3

| Č.p.  | specifikace |   |
|-------|-------------|---|
| 17980 | T30 x 35 mm | 3 |
| 17981 | T40 x 35 mm | 3 |
| 17982 | T45 x 35 mm | 3 |
| 17983 | T50 x 35 mm | 3 |



BIT SD



MOQ 5

| Nu.   | specificatie |   |
|-------|--------------|---|
| 18855 | SD 6 x 25 mm | 5 |
| 18856 | SD 8 x 25 mm | 5 |



BIT T



MOQ 3

| Nu.   | specificatie |   |
|-------|--------------|---|
| 17970 | T20 x 75 mm  | 3 |
| 17971 | T25 x 75 mm  | 3 |
| 17972 | T30 x 75 mm  | 3 |
| 17973 | T40 x 75 mm  | 3 |

| Nu.   | specificatie |   |
|-------|--------------|---|
| 17974 | T45 x 75 mm  | 3 |
| 17975 | T50 x 75 mm  | 3 |
| 17976 | T55 x 75 mm  | 3 |



BIT TS



MOQ 5

| Nu.   | specificatie |   |
|-------|--------------|---|
| 18864 | TS 4 x 25 mm | 5 |
| 18865 | TS 6 x 25 mm | 5 |



BIT 5/32', 3/16'



MOQ 5

| Nu.   | specificatie |   |
|-------|--------------|---|
| 18866 | 5/32 x 25 mm | 5 |
| 18867 | 3/16 x 25 mm | 5 |



BIT TW



MOQ 5

| Nu.   | specificatie |   |
|-------|--------------|---|
| 18860 | TW 1 x 25 mm | 5 |
| 18861 | TW 2 x 25 mm | 5 |
| 18862 | TW 3 x 25 mm | 5 |
| 18863 | TW 4 x 25 mm | 5 |



BIT XZN



MOQ 5

| Nu.   | specificatie |   |
|-------|--------------|---|
| 18870 | M4 x 25 mm   | 5 |
| 18871 | M5 x 25 mm   | 5 |
| 18872 | M6 x 25 mm   | 5 |
| 18873 | M8 x 25 mm   | 5 |
| 18874 | M10 x 25 mm  | 5 |



BIT ADAPTER

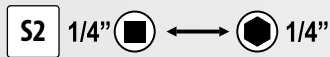

MOQ 5

| Nu.   | specificatie |   |
|-------|--------------|---|
| 18868 | 25 mm        | 5 |



BIT ADAPTER

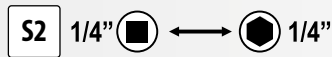

MOQ 5

| Nu.   | specificatie |   |
|-------|--------------|---|
| 18869 | 50 mm        | 5 |



**FESTA**

BIT PENTRU GIPS



| Nu.   | specificație |    |
|-------|--------------|----|
| 18795 | PH 2 x 25 mm | 24 |



**FESTA**

BIT PENTRU GIPS



| Nu.   | specificație |    |
|-------|--------------|----|
| 18796 | PH 2 x 55 mm | 24 |



**FESTA**  
INDUSTRY

ADAPTER  
RATCHET 1/4" - BIT

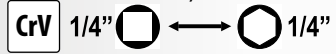

| Nu.   | specificație |   |
|-------|--------------|---|
| 18619 |              | 5 |



**FESTA**  
INDUSTRY

ADAPTOR BITURI,  
MAGNETIC



| Nu.   | specificație |   |
|-------|--------------|---|
| 18600 | 1/4" x 60 mm | 5 |



**FESTA**  
INDUSTRY

ADAPTOR BITURI,  
MAGNETIC



| Nu.   | specificație |   |
|-------|--------------|---|
| 18601 | 1/4" x 60 mm | 5 |



**FESTA**  
INDUSTRY

ADAPTOR BITURI,  
MAGNETIC



| Nu.   | specificație |   |
|-------|--------------|---|
| 18602 | 1/4" x 60 mm | 5 |



**FESTA**  
INDUSTRY

ADAPTOR BITURI,  
MAGNETIC



| Nu.   | specificație |   |
|-------|--------------|---|
| 18797 | 1/4" x 60 mm | 1 |



**FESTA**  
INDUSTRY

ADAPTOR BITURI,  
MAGNETIC



| Nu.   | specificație |   |
|-------|--------------|---|
| 18798 | 1/4" x 60 mm | 1 |



**FESTA**  
INDUSTRY

ADAPTOR BITURI,  
MAGNETIC



| Nu.   | specificație |   |
|-------|--------------|---|
| 18799 | 1/4" x 60 mm | 1 |



**FESTA**  
INDUSTRY

ADAPTOR BITURI,  
MAGNETIC



| Nu.   | specificație |   |
|-------|--------------|---|
| 18605 | 150 mm       | 1 |



**FESTA**

ADAPTOR SDS +  
NA BITURI 1/4"



| Nu.   | specificație |   |
|-------|--------------|---|
| 20743 | 75 mm        | 1 |



ADAPTOR BITURI,  
MAGNETIC

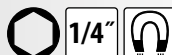

| Nu.   | specificație |    |
|-------|--------------|----|
| 18607 | 80 mm        | 25 |



**FESTA**

ADAPTOR BITURI,  
MAGNETIC



| Nu.   | specificatie |    |
|-------|--------------|----|
| 18609 | 90mm         | 25 |

NEW

**WEST  
BERG**

ADAPTOR  
BIT 1/4" - SDS +

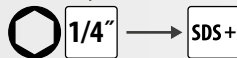

| Nu.   | specificatie |   |
|-------|--------------|---|
| 20742 |              | 1 |

NEW

**FESTA  
INDUSTRY**

BITURI  
SI ADAPTOARE

- 10x ⊕ 18630 PH0
- 10x ⊕ 18631 PH1
- 10x ⊕ 18632 PH2
- 10x ⊕ 18633 PH3
- 10x ⊕ 18635 PZ0
- 10x ⊕ 18636 PZ1
- 10x ⊕ 18637 PZ2
- 10x ⊕ 18638 PZ3
- 10x ⊕ 18761 PH1 TiN
- 10x ⊕ 18762 PH2 TiN
- 10x ⊕ 18763 PH3 TiN
- 10x ⊕ 18766 PZ1 TiN
- 10x ⊕ 18767 PZ2 TiN
- 10x ⊕ 18768 PZ3 TiN
- 10x ⊕ 18770 PH1 DIAMANT
- 10x ⊕ 18771 PH2 DIAMANT
- 10x ⊕ 18775 PZ1 DIAMANT
- 10x ⊕ 18776 PZ2 DIAMANT
- 10x ⊙ 18814 4,0HTa
- 10x ⊙ 18815 5,0HTa
- 10x ⊕ 18842 20TTa
- 10x ⊕ 18845 30TTa
- 10x ⊕ 18795 PH2 Bit pentru gips
- 5x 18612 ADAPTER 1/4" 8mm
- 5x 18613 ADAPTER 1/4" 10mm
- 5x 18600 1/4" 60mm adaptor bituri, magnetic
- 5x 18601 1/4" 60mm adaptor bituri, magnetic
- 5x 18602 1/4" 65mm adaptor bituri, magnetic

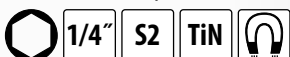

| Nu.   | specificatie |   |
|-------|--------------|---|
| 18993 |              | 1 |

**FESTA  
INDUSTRY**

BITURI

- 10x ⊕ 18631 PH1
- 10x ⊕ 18632 PH2
- 10x ⊕ 18633 PH3
- 10x ⊕ 18636 PZ1
- 10x ⊕ 18637 PZ2
- 10x ⊕ 18638 PZ3
- 10x ⊕ 18761 PH1 TiN
- 10x ⊕ 18762 PH2 TiN
- 10x ⊕ 18763 PH3 TiN
- 10x ⊕ 18766 PZ1 TiN
- 10x ⊕ 18767 PZ2 TiN
- 10x ⊕ 18768 PZ3 TiN
- 10x ⊙ 18804 H 4
- 10x ⊙ 18805 H 5
- 10x ⊕ 18825 T 10
- 10x ⊕ 18826 T 15
- 10x ⊕ 18827 T 20
- 10x ⊕ 18828 T 25
- 10x ⊕ 18830 T 30
- 10x ⊕ 18831 T 40

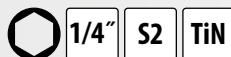

| Nu.   | specificatie |   |
|-------|--------------|---|
| 18994 |              | 1 |

**FESTA  
INDUSTRY**

ADAPTOR 1/4"

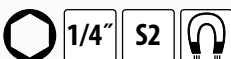

| Nu.   | specificatie |   |
|-------|--------------|---|
| 18610 | 6 mm         | 5 |
| 18611 | 7 mm         | 5 |
| 18612 | 8 mm         | 5 |
| 18613 | 10 mm        | 5 |
| 18614 | 12 mm        | 5 |
| 18615 | 13 mm        | 5 |

**FESTA  
INDUSTRY**

ADAPTOR 1/4"

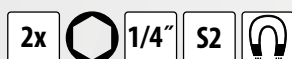

| Nu.    | specificatie |   |
|--------|--------------|---|
| 18610A | 6 mm         | 5 |
| 18611A | 7 mm         | 5 |
| 18612A | 8 mm         | 5 |
| 18613A | 10 mm        | 5 |
| 18614A | 12 mm        | 5 |
| 18615A | 13 mm        | 5 |

**FESTA**

SET ADAPTOARE MAGNETIC

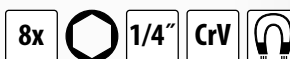

| Nu.   | specificatie                  |    |
|-------|-------------------------------|----|
| 18618 | 6, 7, 8, 9, 10, 11, 12, 13 mm | 12 |







**FESTA**

**BITURI SET**

- bit 25 mm
- ⊖ S 3 · 4 · 5 · 6
- ⊕ PH 0 · 1 · 2 · 3
- ⊛ PZ 0 · 1 · 2 · 3
- H 3 · 4 · 5 · 6
- ⊛ T 10 · 15 · 20 · 25 · 27 · 30 · 40
- ⊛ TTa 10 · 15 · 20 · 25 · 27 · 30 · 40

portbit

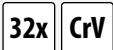

| Nu.   | specificatie |
|-------|--------------|
| 18908 | 1            |



**FESTA**

**SET BITURI**

- ⊕ S 3 · 4 · 5 · 6
  - PH 1 · 2 · 3
  - ⊖ PZ 1 · 2 · 3
  - H 3 · 4 · 5 · 6
  - ⊛ T 10 · 15 · 20 · 25 · 27 · 30 · 40
  - ⊛ TTa 10 · 15 · 20 · 25 · 27 · 30 · 40
- adaptor bituri, magnetic

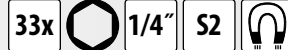

| Nu.   | specificatie |
|-------|--------------|
| 18905 | 10           |



**FESTA**

**SET BITURI**

- ⊕ S 4 · 5 · 6
  - ⊖ PH 1 · 2 · 3
  - ⊛ PZ 1 · 2 · 3
  - ⊛ H 3 · 4 · 5 · 6
  - ⊛ T 10 · 15 · 20 · 25 · 27 · 30 · 40
  - TTa 10 · 15 · 20 · 25 · 27 · 30 · 40
- adaptor bituri, magnetic

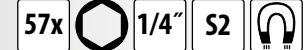

| Nu.   | specificatie |
|-------|--------------|
| 18906 | 6            |

**FESTA**

**BITURI SET**

- ⊛ HTa 2 · 2.5 · 3 · 4 · 5 · 6
  - 5/32" · 9/64" · 1/8"
  - 7/64" · 3/32" · 5/64"
  - ⊖ SD 4 · 6 · 8 · 10
  - ⊛ TS 6 · 8 · 10
  - ⊛ TW 1 · 2 · 3 · 4
  - ⊛ TTa 8 · 10 · 15 · 20 · 25 · 27 · 30 · 35 · 40
- portbit magnetic

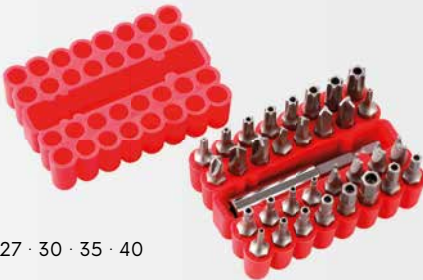

| Nu.   | specificatie |
|-------|--------------|
| 18900 | 10           |

**FESTA**

**BITURI SET**

- ⊖ S 3 · 4 · 4.5 · 5 · 5.5 · 6 · 6.5 · 7 · 8
  - ⊕ PH 0 · 1 · 2 · 3
  - ⊛ PZ 0 · 1 · 2 · 3
  - ⊖ Q 0 · 1 · 2 · 3
  - ⊛ 8 · 10 · 15 · 20 · 25 · 27 · 30 · 40 · 45
  - ⊛ TTa 8 · 10 · 15 · 20 · 25 · 27 · 30 · 35 · 40
  - H 1.5 · 2 · 2.5 · 3 · 4 · 5 · 5.5 · 6 · 8 mm
  - 1/16" · 5/64" · 3/32" · 7/64" · 1/8" · 9/64"
  - 5/32" · 3/16" · 7/32" · 1/4"
  - ⊛ HTa 2 · 2.5 · 3 · 4 · 5 · 6 mm
  - 5/64" · 3/32" · 7/64" · 1/8" · 9/64" · 5/32"
  - ⊖ SD 4 · 6 · 8 · 10
  - ⊛ S 6 · 8 · 10
  - ⊛ TW 1 · 2 · 3 · 4
  - ⊛ 2-wing 1 · 2 · 3
  - ⊛ XZN 5 · 6 · 8
- portbit magnetic,  
portbit Y



1/4" DR surubelnita cu portbit  
1/4" bit adapter: 25mm, 50mm



| Nu.   | specificatie |
|-------|--------------|
| 18909 | 24           |

**FESTA**

**BITURI SET**

- ⊖ S 3 · 4 · 5 · 6 · 7
  - ⊛ PH 0 · 1 · 2 · 3
  - PZ 1 · 2 · 3
  - ⊕ H 2 · 2.5 · 3 · 4 · 5 · 6
  - ⊛ T 10 · 15 · 20 · 25 · 30 · 40
- portbit magnetic



| Nu.   | specificatie |
|-------|--------------|
| 18901 | 10           |

**BITURI SET**

- ⊖ S 4 · 5 · 6 · 7
- ⊕ PH 1 · 2 · 3
- ⊛ PZ 1 · 2 · 3
- H 4 · 5 · 6
- ⊛ T 10 · 15 · 20 · 25
- SQ 1 · 2 · 3

**20x** **S2**



**10x** **CrV** **TiN**

| Nu.   | specificație |    |
|-------|--------------|----|
| 18907 |              | 10 |



**BITURI SET**

- ⊖ S 4 · 5 · 6 · 7
- ⊕ PH 1 · 2 · 3
- ⊛ PZ 1 · 2 · 3



**10x** **CrV** **TiN**

| Nu.   | specificație |    |
|-------|--------------|----|
| 18440 |              | 10 |

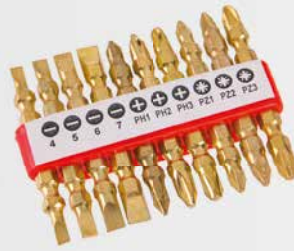

**BITURI SET**

- ⊖ S 3 · 5 · 7
- ⊕ PH 1 · 2 · 3

portbit magnetic

**7x** **HOBBY**



| Nu.   | specificație |    |
|-------|--------------|----|
| 18430 |              | 20 |



**BITURI SET**

- ⊕ S 3 · 3,5 · 4 · 5,5
- ⊛ PH 0 · 1 · 2 · 3
- ⊖ PZ 0 · 1 · 2 · 3
- H 3 · 4
- ⊛ T 10 · 15 · 20 · 25 · 27 · 30
- 1/4" 4 · 4,5 · 5 · 5,5 · 6 · 7 · 8 · 9 · 10 · 11 · 13

surubelnita cu portbit  
portbit magnetic

**CrV** **1/4"**

**40x**



| Nu.   | specificație |    |
|-------|--------------|----|
| 18915 |              | 10 |



**SET UNELTE**

- ⊖ S 5 · 6 mm
- ⊕ PH 1 · 2
- H 3 · 4 · 5 · 6
- ⊛ T 15 · 20 · 25 · 30
- 1/4" 4 · 5 · 6 · 7 · 8 · 9 · 10 · 12 · 13 mm

75 mm 1/4"   
 1/4" ↔ 1/4"

**1/4"** **CrV**

**23x**



| Nu.   | specificație |    |
|-------|--------------|----|
| 18421 |              | 10 |





- 1/2", 1/4"
- 1/4" · 4-5-6-7-8-9mm
- 1/2" · 10-12-13-14-17-19mm
- 1/4" · 4-4.5-5-5.5-6-7-8-9-10-11-12-13-14mm
- 1/2" · 12-13-14-15-16-17-18-19-20-21-22-24mm
- 1/2", 1/4"
- 1/4" 1/4"
- 1/4" · 150mm
- 1/2" · 254mm
- 1/2", 1/4"
- 1/2" · 16-21mm
- 1/4" · 150mm
- 1/2" · E10-E12-E14-E16-E18-E20-E22-E24
- 1/4" S 3 · 4 · 5 · 6
- 1/4" PH 0 · 1 · 2
- 1/4" PZ 0 · 1 · 2
- 1/4"
- 1/4" · S 4 · 5,5 · 6,5
- 1/4" PH 1 · 2 · 3
- 1/4" PZ 2 · 3
- 1/4" H 3 · 4 · 5 · 6
- 1/4" T 8 · 10 · 15 · 20 · 25
- 1/4" TTa 10 · 15 · 20 · 25 · 40
- 2 · 2,5 · 3 · 4 · 5 · 6 · 7 · 8 · 10mm
- 8-9-10-11-12-13-14-15-16-17-18-19mm
- S 4x100 · 6,5x150
- PH 2x100 · 3x150
- 180mm
- 160mm
- 160mm
- 250mm
- 300g

**FESTA**

## SET UNELTE

122x CrV S2 1/4" 1/2" 72T

Nu. 17238 specificatie 122 buc



1



## SET UNELTE

- 160 mm
- 160 mm
- 300 g
- 1/4" 45T
- 4 · 5 · 6 · 7 · 8 · 9 · 10 · 11 · 12 · 13 mm
- 1/4" 75 mm
- 1,5 · 2 · 2,5 · 3 · 4 · 5 · 6 · 8 · 10 mm
- S 3 · 4 · 5 · 6 mm
- PH 0 · 1 · 2 · 3
- PZ 0 · 1 · 2 · 3
- T 10 · 15 · 20 · 25
- H 3 · 4 · 5 · 6
- S 5x100 mm
- PH 1x100 · 2x100 mm
- S 2,5x50 mm
- PH 00x50 · 0x50 mm
- AC 100-250 V
- 200 mm max. 22 mm
- 10x11 · 12x13 · 14x15 · 16x17 mm
- 18 mm
- 2 mm 13 mm

60x



35x

Nu. 17259 specificatie 5



## SET UNELTE

- 120mm
- 125mm
- 115mm
- 150mm max. 19mm
- 9mm
- 
- 
- 1/4" 160mm
- 5 · 6 · 7 · 8 · 9 · 10 · 11 mm
- 1/4"
- 1/4"
- S 4 · 6 mm
- PH 1 · 2 · 3
- PZ 1 · 2
- H 4 · 5 · 6

Nu. 17260 specificatie 10



## SET UNELTE

- 1/4" 5 · 6 · 7 · 8 · 9 · 10 · 11 · 12 mm
- 1/4"
- 1/4"
- AC 230 V
- PH 0, SL 3
- 9x 1,5-10 mm
- 160 mm
- S 3 · 4 · 5 · 6 mm
- PH 0 · 1 · 2 · 3
- H 4 · 5
- PH 2x100, S 6x100
- 18 mm
- 1 m
- 300 g

39x



Nu. 17247 specificatie 10

# FESTA

10 years  
garantie











































Cr-Mo

- Utilizare în industrie și service
- Oțel Crom vanadiu de calitate
- Dispozitiv cu clichet cu 72 de dinți șlefuiți
- Toate componentele potrivit normei DIN
- capetele crestate pentru o apucare mai bună
- Valiză rezistentă cu broaște și balamale metalice



**FESTA**

## SET CHEI TUBULARE

-  1/2", 1/4", 3/8"
-  1/4" · 4-5-6-7-8-9-10mm
-  3/8" · 10-11-12-13-14-15mm
-  1/2" · 16-17-18-19-22mm
-  1/4" · 4-4.5-5-5.5-6-7-8-9-10-11-12-13-14mm
-  3/8" · 10-11-12-13-14-15-16-17-18-19mm
-  1/2" · 10-11-12-13-14-15-16-17-18-19-20-21-22-24-27-30-32mm
-  1/4" · E4-E5-E6-E7-E8
-  3/8" · E10-E11-E12-E14-E16-E18
-  1/2" · E20-E24
-  1/2" ·       24x
-  1/4" ·       20x
-  1/4" ·       30x
-  1/4" · 50 mm, 100 mm
-  1/2" · 125 mm, 250 mm
-  3/8" · 150 mm
-  1/2" · 16-21mm
-  3/8" · 18mm
-  1/2", 1/4", 3/8" bit holder
-  1/2", 1/4", 3/8"
-  1/4" · 150mm
-  1/4" · 115mm
-  Inbus 7X



10 years  
garantie



Nu. specificație

17237

2



**FESTA**

SET CHEI TUBULARE

- 1/2" · 72T
- 1/2" · 125 mm
- 1/2" · 10-11-12-13-14-15-17-19-22-24 mm

10 years guarantee

CrV 1/2" 72T 12x ERGO HANDLE

Č.p. specifikace 17245 15



**FESTA**

SET CHEI TUBULARE

- 1/2" · 72T
- 1/2" · 125 mm
- 1/2" · 10-11-12-13-14-15-17-19-22-24 mm

10 years guarantee

CrV 1/2" 72T 12x ERGO HANDLE

Č.p. specifikace 17229 8



**FESTA**

SET CHEI TUBULARE

- 1/2" · 72 T
- 1/2" · 75, 125 mm
- 1/2"
- 1/2" · 10-11-12-13-14-15-16-17-18-19-22-24 mm
- 1/2" · 17mm, 19mm
- 3 way adapter
- 16mm, 21mm

10 years guarantee

CrV 1/2" 72T 20x ERGO HANDLE

Č.p. specifikace 17230 4



**FESTA**

SET CHEI TUBULARE

- 1/4" · 72 T
- 1/4" · 50, 100 mm
- 1/4"
- 1/4" · 4-5-5.5-6-7-8-10-11-12-13 mm
- 1/4" · 6-7-8-10-12-13 mm
- 3 way adapter
- 4 x
- 11x
- 1x

10 years guarantee

CrV S2 1/4" 72T 36x ERGO HANDLE

Č.p. specifikace 17231 10



**FESTA**

SET CHEI TUBULARE

- 1/4"
- 1/4"
- 1/4" · 4-4.5-5-5.5-6-7-8-9-10-11-12-13-14 mm
- 1/4" · 50 mm, 100 mm
- 1/4"
- 1/4"
- 21 x
- 1/4"
- L 1/4"

10 years guarantee

CrV S2 1/4" 72T 45x ERGO HANDLE

Č.p. specifikace 17233 10



**FESTA**

SET CHEI TUBULARE

- 1/2", 1/4" · 72T
- 1/4"
- 16 mm, 21 mm
- 1/4" · 10-11-12-13-14-15-16-17-18-19-20-21-22-23-24-27 mm
- 1/4" · 100 mm
- 1/2" · 125 mm, 250 mm
- 1/4"
- 1x
- 1/4" · 4-5-5.5-6-7-8-10-11-12-13 mm
- 33 x











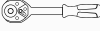



10 years guarantee

CrV S2 1/4" 1/2" 72T 73x ERGO HANDLE

Č.p. specifikace 17234 4

**FESTA**

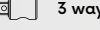
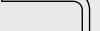
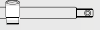
**SET CHEI TUBULARE**

-  1/2", 1/4" · 72T
-  1/4"
-  16 mm, 21 mm
-  1/4" · 4 -4,5-5-5,5-6-7-8-9-10-11-12-13-14 mm
-  1/2" · 10-11-12-13-14-15-16-17-18-19-20-21-22-23-24-27-30-32 mm
-  1/4" · 6-7-8-9-10-11-12-13 mm
-  1/2" · 14-15-17-19 mm
-  1/4" · 50 mm, 100 mm
-  1/2" · 125 mm, 250 mm
-  1/4"
-  5/16" bit holder
-  17x
-  15x
-  3 way adapter
-  3 x
-  1/4"
-  L 1/4"
-  1/2", 1/4"

CrV S2 1/4" 1/2" 72T 94x ERGO HANDLE













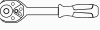
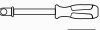



10 years guarantee

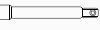

|       |             |
|-------|-------------|
| Č.p.  | specifikace |
| 17235 | 4           |

**FESTA**

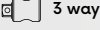
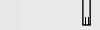
**SET CHEI TUBULARE**

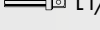
-  1/2", 1/4" · 72T
-  150 mm
-  16 mm, 21 mm
-  1/4" · 4 -4,5-5-5,5-6-7-8-9-10-11-12-13-14 mm
-  1/2" · 10-11-12-13-14-15-16-17-18-19-20-21-22-24-27-30-32 mm
-  1/4" · 6-7-8-9-10-11-12-13 mm
-  1/2" · 14-15-17-19-22 mm
-  1/4" · 50 mm, 100 mm
-  1/2" · 125 mm, 250 mm
-  E · 4-5-6-7-8-10-11-12-14-16-18-20-24-27-30-32 mm
-  1/2", 1/4"
-  5/16" bit holder
-  18 x
-  17 x
-  3 way adapter
-  4 x
-  1/4"
-  L 1/4"

CrV S2 1/4" 1/2" 72T 110x ERGO HANDLE













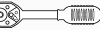







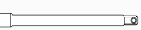

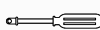

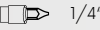
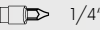
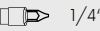
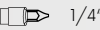
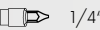
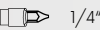

10 years guarantee



|       |             |
|-------|-------------|
| Č.p.  | specifikace |
| 17236 | 4           |

**FESTA**

**SET UNELTE**

-  1/2", 1/4"
-  1/4" · 4-5-6-7-8-9mm
-  1/2" · 10-12-13-14-17-19mm
-  1/4" · 4-4,5-5-5,5-6-7-8-9-10-11-12-13-14mm
-  1/2" · 12-13-14-15-16-17-18-19-20-21-22-24mm
-  1/2", 1/4"
-  1/4" · 4-4,5-5-5,5-6-7-8-9-10-11-12-13-14mm
-  1/4" · 150mm
-  1/2" · 254mm
-  1/2", 1/4"
-  1/2" · 16-21mm
-  1/4" · 150mm
-  1/2" · E10-E12-E14-E16-E18-E20-E22-E24
-  1/4" · S 3 · 4 · 5 · 6
-  1/4" · PH 0 · 1 · 2
-  1/4" · PZ 0 · 1 · 2
-  1/4" · S 4 · 5,5 · 6,5
-  1/4" · PH 1 · 2 · 3
-  1/4" · PZ 2 · 3
-  1/4" · H 3 · 4 · 5 · 6
-  1/4" · T 8 · 10 · 15 · 20 · 25
-  1/4" · TTα 10 · 15 · 20 · 25 · 40
-  2 · 2,5 · 3 · 4 · 5 · 6 · 7 · 8 · 10mm
-  8-9-10-11-12-13-14-15-16-17-18-19mm
-  S 4x100 · 6,5x150
-  PH 2x100 · 3x150
-  180mm
-  160mm
-  160mm
-  250mm
-  300g

CrV S2 1/4" 1/2" 72T 122x ERGO HANDLE



|       |             |
|-------|-------------|
| Č.p.  | specifikace |
| 17238 | 122 ks 1    |



**FESTA**



**FESTA**



RATCHET FESTA

- Ratchet is made from the best quality ChromVanadium steel
- Ratchet with 72 teeth for most precise work
- Quality ergonomic, two-component handle made of softened TPE rubber
- SYSTEM QUICK RELEASE for quick and easy changing of socket heads



**FESTA**  
RATCHET



| Č.p.  | specifikace | délka  |   |
|-------|-------------|--------|---|
| 17297 | 1/4"        | 155 mm | 6 |
| 17298 | 3/8"        | 210 mm | 5 |
| 17299 | 1/2"        | 255 mm | 4 |

**FESTA**  
RATCHET



| Č.p.  | specifikace | délka  |    |
|-------|-------------|--------|----|
| 17240 | 1/4"        | 155 mm | 10 |
| 17241 | 3/8"        | 200 mm | 10 |
| 17242 | 1/2"        | 250 mm | 5  |

**FESTA**  
RATCHET



| Č.p.  | specifikace | délka  |    |
|-------|-------------|--------|----|
| 17294 | 1/4"        | 155 mm | 6  |
| 17295 | 3/8"        | 205 mm | 10 |
| 17296 | 1/2"        | 255 mm | 4  |

**FESTA**  
RATCHET 1/4"

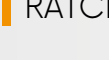

| Č.p.  | specifikace |   |
|-------|-------------|---|
| 17292 | 1/4"        | 1 |

RATCHET  
**HOBBY**



| Č.p.  | specifikace |    |
|-------|-------------|----|
| 17243 | 1/4" 43T    | 25 |
| 17244 | 1/2" 39T    | 25 |

**FESTA**  
ADAPTOR PENTRU  
CHEI HEXAGONALE

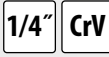

| Č.p.  | specifikace |    |
|-------|-------------|----|
| 18603 | 1/4" 150 mm | 10 |





**FESTA**

CHEI TUBULARE 1/4'



| Č.p.  | specifikace    |    |
|-------|----------------|----|
| 17820 | 4 mm • 25 mm   | 10 |
| 17821 | 4,5 mm • 25 mm | 10 |
| 17822 | 5 mm • 25 mm   | 10 |
| 17823 | 5,5 mm • 25 mm | 10 |
| 17824 | 6 mm • 25 mm   | 10 |
| 17825 | 7 mm • 25 mm   | 10 |
| 17826 | 8 mm • 25 mm   | 10 |
| 17827 | 9 mm • 25 mm   | 10 |
| 17828 | 10 mm • 25 mm  | 10 |
| 17829 | 11 mm • 25 mm  | 10 |
| 17830 | 12 mm • 25 mm  | 10 |
| 17831 | 13 mm • 25 mm  | 10 |
| 17832 | 14 mm • 25 mm  | 10 |



**FESTA**

CHEI TUBULARE 1/2'



| Č.p.  | specifikace   |    |
|-------|---------------|----|
| 17308 | 8 mm • 38 mm  | 10 |
| 17309 | 9 mm • 38 mm  | 10 |
| 17310 | 10 mm • 38 mm | 10 |
| 17311 | 11 mm • 38 mm | 10 |
| 17312 | 12 mm • 38 mm | 10 |
| 17313 | 13 mm • 38 mm | 10 |
| 17314 | 14 mm • 38 mm | 10 |
| 17315 | 15 mm • 38 mm | 10 |
| 17316 | 16 mm • 38 mm | 10 |
| 17317 | 17 mm • 38 mm | 10 |
| 17318 | 18 mm • 38 mm | 10 |
| 17319 | 19 mm • 38 mm | 10 |
| 17320 | 20 mm • 38 mm | 10 |
| 17321 | 21 mm • 38 mm | 10 |
| 17322 | 22 mm • 38 mm | 10 |
| 17324 | 24 mm • 38 mm | 10 |
| 17327 | 27 mm • 42 mm | 20 |
| 17330 | 30 mm • 42 mm | 25 |
| 17332 | 32 mm • 42 mm | 20 |
| 17333 | 34 mm • 42 mm | 20 |
| 17334 | 36 mm • 42 mm | 20 |



**FESTA**

CHEI TUBULARE 3/4'



| Č.p.  | specifikace   |    |
|-------|---------------|----|
| 17835 | 17 mm • 48 mm | 10 |
| 17836 | 18 mm • 48 mm | 10 |
| 17837 | 19 mm • 48 mm | 10 |
| 17838 | 21 mm • 48 mm | 10 |
| 17839 | 22 mm • 48 mm | 10 |
| 17840 | 24 mm • 48 mm | 10 |
| 17841 | 26 mm • 48 mm | 10 |
| 17842 | 27 mm • 52 mm | 10 |
| 17843 | 28 mm • 52 mm | 10 |
| 17844 | 30 mm • 52 mm | 10 |
| 17845 | 32 mm • 52 mm | 10 |
| 17846 | 33 mm • 55 mm | 10 |
| 17847 | 36 mm • 60 mm | 10 |
| 17848 | 38 mm • 60 mm | 10 |
| 17849 | 41 mm • 65 mm | 10 |
| 17850 | 46 mm • 65 mm | 10 |
| 17851 | 50 mm • 70 mm | 10 |
| 17852 | 55 mm • 75 mm | 10 |
| 17853 | 60 mm • 78 mm | 10 |
| 17854 | 65 mm • 82 mm | 10 |
| 17855 | 70 mm • 82 mm | 10 |
| 17856 | 75 mm • 88 mm | 10 |



**FESTA**

CHEI TUBULARE MULTIDRIVE 1/2'

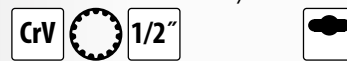

| Č.p.  | specifikace   |    |
|-------|---------------|----|
| 17910 | 8 mm • 38 mm  | 10 |
| 17914 | 12 mm • 38 mm | 10 |
| 17916 | 14 mm • 38 mm | 10 |
| 17922 | 21 mm • 38 mm | 10 |
| 17924 | 24 mm • 38 mm | 10 |
| 17926 | 30 mm • 38 mm | 10 |



**FESTA**

CHEI TUBULARE 1/4'



| Č.p.  | specifikace   |    |
|-------|---------------|----|
| 17860 | 4 mm • 50 mm  | 10 |
| 17861 | 5 mm • 50 mm  | 10 |
| 17862 | 6 mm • 50 mm  | 10 |
| 17863 | 7 mm • 50 mm  | 10 |
| 17864 | 8 mm • 50 mm  | 10 |
| 17865 | 9 mm • 50 mm  | 10 |
| 17866 | 10 mm • 50 mm | 10 |
| 17867 | 11 mm • 50 mm | 10 |
| 17868 | 12 mm • 50 mm | 10 |
| 17869 | 13 mm • 50 mm | 10 |
| 17870 | 14 mm • 50 mm | 10 |



**FESTA**

CHEI TUBULARE (LUNG) 1/2'

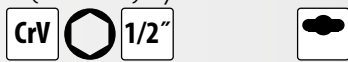

| Č.p.  | specifikace   |    |
|-------|---------------|----|
| 17871 | 10 mm • 70 mm | 10 |
| 17872 | 11 mm • 70 mm | 10 |
| 17873 | 12 mm • 70 mm | 10 |
| 17874 | 13 mm • 70 mm | 10 |
| 17875 | 14 mm • 70 mm | 10 |
| 17876 | 15 mm • 70 mm | 10 |
| 17877 | 16 mm • 70 mm | 10 |
| 17878 | 17 mm • 70 mm | 10 |
| 17879 | 18 mm • 70 mm | 10 |
| 17880 | 19 mm • 70 mm | 10 |
| 17881 | 20 mm • 70 mm | 10 |
| 17882 | 21 mm • 70 mm | 10 |
| 17883 | 22 mm • 70 mm | 10 |
| 17884 | 23 mm • 70 mm | 10 |
| 17885 | 24 mm • 70 mm | 10 |
| 17886 | 25 mm • 70 mm | 10 |
| 17887 | 26 mm • 70 mm | 10 |
| 17888 | 27 mm • 70 mm | 10 |
| 17889 | 28 mm • 70 mm | 10 |
| 17890 | 30 mm • 70 mm | 10 |
| 17891 | 32 mm • 70 mm | 10 |
| 17892 | 34 mm • 70 mm | 10 |



**FESTA**

CHEI TUBULARE TORX 1/2'



| Č.p.  | specifikace |    |
|-------|-------------|----|
| 17943 | E22         | 10 |
| 17944 | E24         | 10 |



**FESTA**

CHEI TUBULARE TORX 1/4'

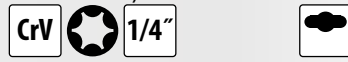

| Č.p.  | specifikace |    |
|-------|-------------|----|
| 17930 | E4          | 10 |
| 17934 | E8          | 10 |
| 17935 | E10         | 10 |





**FESTA**

SLOTTED CHEI TUBULARE BIT 1/4'

| CrV   | S2          | 1/4" |  |
|-------|-------------|------|--|
| Č.p.  | specifikace |      |  |
| 18920 | S 4 mm      | 10   |  |
| 18921 | S 5,5 mm    | 10   |  |
| 18922 | S 7 mm      | 10   |  |



**FESTA**

PHILIPS CHEI TUBULARE BIT 1/4'

| CrV   | S2          | 1/4" |  |
|-------|-------------|------|--|
| Č.p.  | specifikace |      |  |
| 18925 | PH 1        | 10   |  |
| 18926 | PH 2        | 10   |  |
| 18927 | PH 3        | 10   |  |



**FESTA**

POZIDRIVE CHEI TUBULARE BIT 1/4'

| CrV   | S2          | 1/4" |  |
|-------|-------------|------|--|
| Č.p.  | specifikace |      |  |
| 18928 | PZ 0        | 10   |  |
| 18929 | PZ 1        | 10   |  |
| 18930 | PZ 2        | 10   |  |
| 18931 | PZ 3        | 10   |  |



**FESTA**

TORX CHEI TUBULARE BIT 1/2'

| CrV   | S2          | 1/2" |  |
|-------|-------------|------|--|
| Č.p.  | specifikace |      |  |
| 18954 | T 10        | 10   |  |
| 18955 | T 15        | 10   |  |
| 18956 | T 20        | 10   |  |
| 18960 | T 40        | 10   |  |
| 18961 | T 45        | 10   |  |
| 18963 | T 55        | 10   |  |



**FESTA**

TORX CHEI TUBULARE BIT 1/4'

| CrV   | S2          | 1/4" |  |
|-------|-------------|------|--|
| Č.p.  | specifikace |      |  |
| 18948 | T 5         | 10   |  |
| 18950 | T 8         | 10   |  |
| 18951 | T 10        | 10   |  |



**FESTA**

HEX CHEI TUBULARE BIT 1/4'

| CrV   | S2          | 1/4" |  |
|-------|-------------|------|--|
| Č.p.  | specifikace |      |  |
| 18934 | 3 mm        | 10   |  |
| 18939 | 8 mm        | 10   |  |



**FESTA**

TORX CHEI TUBULARE BIT 1/2'

| CrV   | S2          | 1/2" |  |
|-------|-------------|------|--|
| Č.p.  | specifikace |      |  |
| 18971 | M 16        | 10   |  |



**FESTA**

CURSOR

| CrV   |             |   |
|-------|-------------|---|
| Č.p.  | specifikace |   |
| 17420 | 1/4"        | 1 |
| 17421 | 1/2"        | 1 |
| 17422 | 3/4"        | 1 |



**FESTA**

ADAPTOR

| CrV   |                   |    |
|-------|-------------------|----|
| Č.p.  | specifikace       |    |
| 17410 | A - 1/4" B - 3/8" | 10 |
| 17411 | A - 3/8" B - 1/4" | 10 |
| 17412 | A - 3/8" B - 1/2" | 10 |
| 17413 | A - 1/2" B - 3/8" | 10 |
| 17414 | A - 1/2" B - 3/4" | 10 |
| 17415 | A - 3/4" B - 1/2" | 10 |
| 17416 | A - 1/4" B - 1/2" | 10 |



**FESTA**

PRELUNGITOR

| CrV   |               |   |
|-------|---------------|---|
| Č.p.  | specifikace   |   |
| 17390 | 1/4" • 50 mm  | 1 |
| 17391 | 1/4" • 100 mm | 1 |
| 17392 | 1/4" • 150 mm | 1 |
| 17393 | 1/2" • 75 mm  | 1 |
| 17394 | 1/2" • 125 mm | 1 |
| 17395 | 1/2" • 250 mm | 1 |
| 17396 | 3/4" • 100 mm | 1 |
| 17397 | 3/4" • 200 mm | 1 |
| 17398 | 3/4" • 400 mm | 1 |



**FESTA**

CUPLA CARDANICA

| CrV   |               |    |
|-------|---------------|----|
| Č.p.  | specifikace   |    |
| 17405 | 1/4" • 39 mm  | 10 |
| 17406 | 1/2" • 71 mm  | 10 |
| 17407 | 3/4" • 105 mm | 10 |

**FESTA**

MANER T CU CURSOR

| CrV   |               |   |
|-------|---------------|---|
| Č.p.  | specifikace   |   |
| 17382 | 1/4" • 115 mm | 1 |
| 17383 | 3/8" • 190 mm | 1 |
| 17384 | 1/2" • 250 mm | 1 |
| 17385 | 3/4" • 460 mm | 1 |
| 17386 | 1" • 640 mm   | 1 |

**FESTA**

EXTENSIE T LUNGA CU CUPLA

| CrV   |               |   |
|-------|---------------|---|
| Č.p.  | specifikace   |   |
| 17401 | 1/4" • 250 mm | 1 |
| 17402 | 1/2" • 400 mm | 1 |



**FESTA**  
MANER CU CUPLA

| <b>CrV</b> |               |   |  |
|------------|---------------|---|--|
| Nu.        | specificatie  |   |  |
| 17380      | 1/2" • 350 mm | 1 |  |
| 17381      | 3/4" • 500 mm | 1 |  |



**FESTA**  
MANER INDOIT

| <b>CrV</b> | 1/2"               |   |  |
|------------|--------------------|---|--|
| Nu.        | specificatie       |   |  |
| 17427      | 1/2" • 60 x 320 mm | 1 |  |



**FESTA**  
PRELUNGITOR FLEXIBIL

| <b>CrV</b> | 1/4"          |   |  |
|------------|---------------|---|--|
| Nu.        | specificatie  |   |  |
| 17400      | 1/4" • 150 mm | 1 |  |

**Stahlberg**  
BIT | ADAPTOR  
CLICHET-BITURI 1/4"

| <b>CrV</b> |              |      |  |
|------------|--------------|------|--|
| 1/4"       | ↔            | 1/4" |  |
| Nu.        | specificatie |      |  |
| 18619      |              | 5    |  |



CHEI TUBULARE  
UNIVERSALE

| <b>CrV</b> | 1/2"         |   |  |
|------------|--------------|---|--|
| Nu.        | Specificatie |   |  |
| 17812      | 10 - 19 mm   | 1 |  |



CHEI TUBULARE UNIVERSALE

| <b>CrV</b> | 3/8"                    |   |  |
|------------|-------------------------|---|--|
| Nu.        | specificatie            |   |  |
| 17810      | 7 - 19mm • 52mm x ø26mm | 1 |  |



CHEI TUBULARE UNIVERSALE

| <b>CrV</b> | 1/2"                     |   |  |
|------------|--------------------------|---|--|
| Nu.        | specificatie             |   |  |
| 17811      | 11 - 32mm • 83mm x ø43mm | 5 |  |



SET CHEI TUBULARE DRIVELOCK

| <b>CrV</b> | 1/4"                           | 12x |  |
|------------|--------------------------------|-----|--|
| Ș.p.       | specificatie                   |     |  |
| 17250      | 4-5-5,5-6-7-8-9-10-11-12-13 mm | 10  |  |



SET CHEI TUBULARE TORX

| <b>CrV</b> | 1/2"                                    | 1/4" | 9x |  |
|------------|---|------|----|--|
| Ș.p.       | specificatie                            |      |    |  |
| 17255      | 1/4" • 5-6-7-8-10<br>1/2" • 12-14-16-18 | 4    |    |  |

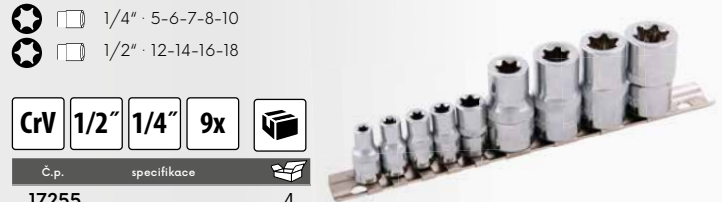

SET ADAPTORI

| <b>CrV</b> | 1/4"             | 3x |  |
|------------|------------------|----|--|
| Nu.        | specificatie     |    |  |
| 18604      | 1/4", 3/8", 1/2" | 10 |  |



**FESTA**  
CHEIE IMBUS  
UNIVERSALA

| <b>CrV</b> | 1/2"           |    |  |
|------------|----------------|----|--|
| Nu.        | specificatie   |    |  |
| 17455      | pro răcnu 1/2" | 10 |  |

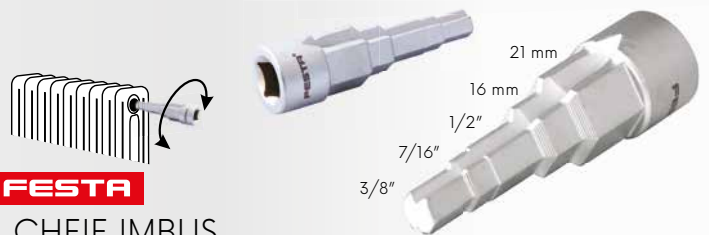

**NEW**



**FESTA**

**SET SURUBELNITE T INBUS + TORX**

- H 2.5 · 3 · 4 · 5 · 6 · 8 · 10 mm
- ★ T 10 · 15 · 20 · 25 · 30 · 40 · 45

**14x CrV**



| Nu.   | specificatie |
|-------|--------------|
| 18501 |              |

1

**FESTA**

**SET SURUBELNITE T TORX**

- 2 mm
- 2,5 mm
- 3 mm
- 4 mm
- 5 mm
- 6 mm
- 7 mm
- 8 mm
- 10 mm

**9x CrV**



| Nu.   | specificatie |
|-------|--------------|
| 18494 |              |

6



**FESTA**

**CHEIE CU MANER TORX**

**CrV**



| Nu.   | specificatie |    |
|-------|--------------|----|
| 17350 | T 7          | 10 |
| 17351 | T 8          | 10 |
| 17352 | T 9          | 10 |
| 17353 | T 10         | 10 |

| Nu.   | specificatie |    |
|-------|--------------|----|
| 17357 | T 27         | 10 |
| 17359 | T 40         | 10 |
| 17361 | T 50         | 10 |

**FESTA**

**SET SURUBELNITE T INBUS**

- T 10
- T 15
- T 20
- T 25
- T 27
- T 30
- T 40
- T 45
- T 50

**9x CrV**



| Nu.   | specificatie |
|-------|--------------|
| 18495 |              |

6



**FESTA**

**IMBUS**

**DIN 911 CrV**



| Č.p.  | specificatie       |   |
|-------|--------------------|---|
| 18567 | 27 mm 100 x 250 mm | 1 |
| 18572 | 32 mm 125 x 315 mm | 1 |

**FESTA**

**IMBUS - LUNG**

**CrV**



| Č.p.  | specificatie      |   |
|-------|-------------------|---|
| 18510 | 1,5 mm 14 x 74 mm | 1 |
| 18511 | 2 mm 16 x 81 mm   | 1 |
| 18512 | 2,5 mm 18 x 88 mm | 1 |
| 18513 | 3 mm 23 x 108 mm  | 1 |
| 18514 | 4 mm 24 x 107 mm  | 1 |
| 18515 | 5 mm 23 x 118 mm  | 1 |
| 18516 | 6 mm 32 x 135 mm  | 1 |
| 18518 | 8 mm 36 x 153 mm  | 1 |
| 18519 | 9 mm 38 x 155 mm  | 1 |
| 18520 | 10 mm 40 x 168 mm | 1 |
| 18521 | 11 mm 40 x 230 mm | 1 |
| 18522 | 12 mm 45 x 237 mm | 1 |
| 18523 | 13 mm 45 x 260 mm | 1 |
| 18524 | 14 mm 55 x 265 mm | 1 |
| 18527 | 17 mm 60 x 298 mm | 1 |

**FESTA**

**IMBUS - LUNG**

**CrV**



| Č.p.  | specificatie      |   |
|-------|-------------------|---|
| 18575 | 1,5 mm 15 x 75 mm | 1 |
| 18576 | 2 mm 17 x 81 mm   | 1 |
| 18577 | 2,5 mm 18 x 87 mm | 1 |
| 18578 | 3 mm 20 x 96 mm   | 1 |
| 18579 | 4 mm 24 x 107 mm  | 1 |
| 18580 | 5 mm 30 x 120 mm  | 1 |
| 18581 | 6 mm 33 x 136 mm  | 1 |
| 18582 | 7 mm 34 x 144 mm  | 1 |
| 18583 | 8 mm 36 x 153 mm  | 1 |
| 18584 | 9 mm 38 x 155 mm  | 1 |
| 18585 | 10 mm 40 x 168 mm | 1 |
| 18587 | 12 mm 45 x 237 mm | 1 |
| 18588 | 13 mm 45 x 210 mm | 1 |
| 18589 | 14 mm 55 x 265 mm | 1 |
| 18593 | 17 mm 60 x 298 mm | 1 |

**FESTA**

**TORX - LUNG**

**CrV**



| Č.p.  | specificatie |   |
|-------|--------------|---|
| 18476 | T45          | 1 |

**FESTA**

SET CHEI IMBUS CRV

- H 1,5 mm
- H 2 mm
- H 2,5 mm
- H 3 mm
- H 4 mm
- H 5 mm
- H 6 mm
- H 8 mm
- H 10 mm



|       |              |   |
|-------|--------------|---|
| Nu.   | specificatie |   |
| 18496 |              | 5 |

**FESTA**

SET CHEI IMBUS

- H 1,5 mm
- H 2 mm
- H 2,5 mm
- H 3 mm
- H 4 mm
- H 5 mm
- H 6 mm
- H 8 mm
- H 10 mm



|       |              |   |
|-------|--------------|---|
| Nu.   | specificatie |   |
| 18500 |              | 5 |

**FESTA**

SET CHEI IMBUS

- H 1,5 mm
- H 2 mm
- H 2,5 mm
- H 3 mm
- H 4 mm
- H 5 mm
- H 6 mm
- H 8 mm
- H 10 mm

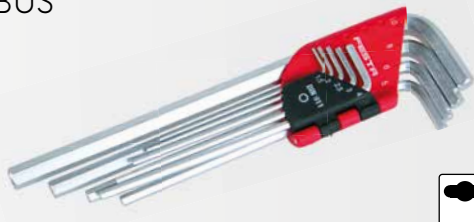

|       |              |   |
|-------|--------------|---|
| Nu.   | specificatie |   |
| 18490 |              | 5 |

**FESTA**

SET CHEI IMBUS

- H 1,5 mm
- H 2 mm
- H 2,5 mm
- H 3 mm
- H 4 mm
- H 5 mm
- H 6 mm
- H 8 mm
- H 10 mm



|       |              |   |
|-------|--------------|---|
| Nu.   | specificatie |   |
| 18498 |              | 5 |

**FESTA**

SET CHEI IMBUS

- 1/16"
- 5/64"
- 3/32"
- 1/8"
- 5/32"
- 3/16"
- 1/4"
- 5/16"
- 3/8"



|       |              |   |
|-------|--------------|---|
| Nu.   | specificatie |   |
| 18493 |              | 6 |

**FESTA**

SET CHEI TORX

- T 10 mm
- T 15 mm
- T 20 mm
- T 25 mm
- T 27 mm
- T 30 mm
- T 40 mm
- T 45 mm
- T 50 mm



|       |              |   |
|-------|--------------|---|
| Nu.   | specificatie |   |
| 18497 |              | 5 |

**FESTA**

SET CHEI IMBUS

- H 1,5 mm
- H 2 mm
- H 2,5 mm
- H 3 mm
- H 4 mm
- H 5 mm
- H 6 mm
- H 8 mm
- H 10 mm



|       |              |    |
|-------|--------------|----|
| Nu.   | specificatie |    |
| 18492 |              | 10 |

**FESTA**

SET CHEI TORX

- T 10 mm
- T 15 mm
- T 20 mm
- T 25 mm
- T 27 mm
- T 30 mm
- T 40 mm
- T 45 mm
- T 50 mm

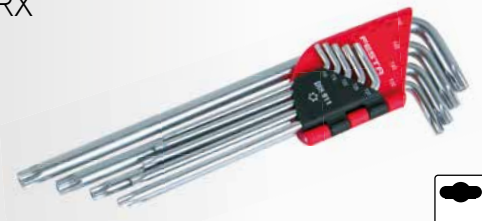

|       |              |   |
|-------|--------------|---|
| Nu.   | specificatie |   |
| 18491 |              | 5 |

**FESTA**

SET CHEI IMBUS



|       |                                  |   |
|-------|----------------------------------|---|
| Nu.   | specificatie                     |   |
| 18508 | 1,5 · 2 · 2,5 · 3 · 4 · 5 · 6 mm | 1 |

IMBUS SET



|       |                                     |   |
|-------|-------------------------------------|---|
| Nu.   | specificatie                        |   |
| 18499 | 2 · 2,5 · 3 · 4 · 5 · 6 · 8 · 10 mm | 1 |



**FESTA**

## CHEI FIXE

CrV DIN 3110



| Nu.   | specificație |    |
|-------|--------------|----|
| 17550 | 6 x 7 mm     | 10 |
| 17551 | 8 x 9 mm     | 10 |
| 17552 | 8 x 10 mm    | 10 |
| 17553 | 10 x 11 mm   | 10 |
| 17590 | 10 x 13 mm   | 10 |
| 17554 | 12 x 13 mm   | 10 |
| 17555 | 14 x 15 mm   | 10 |
| 17556 | 13 x 16 mm   | 10 |
| 17557 | 13 x 17 mm   | 10 |
| 17591 | 14 x 17 mm   | 10 |
| 17558 | 16 x 17 mm   | 10 |
| 17559 | 17 x 19 mm   | 10 |
| 17560 | 18 x 19 mm   | 10 |

| Nu.   | specificație |    |
|-------|--------------|----|
| 17592 | 19 x 22 mm   | 10 |
| 17593 | 19 x 24 mm   | 10 |
| 17561 | 20 x 22 mm   | 10 |
| 17569 | 21 x 23 mm   | 10 |
| 17548 | 22 x 24 mm   | 10 |
| 17562 | 24 x 27 mm   | 10 |
| 17549 | 24 x 30 mm   | 10 |
| 17563 | 30 x 32 mm   | 10 |
| 17564 | 30 x 34 mm   | 10 |
| 17565 | 32 x 36 mm   | 10 |
| 17566 | 36 x 41 mm   | 10 |
| 17567 | 46 x 50 mm   | 10 |
| 17568 | 50 x 55 mm   | 3  |

**FESTA**

## CHEI COMBinate

CrV DIN 3113



| Nu.   | specificație |    |
|-------|--------------|----|
| 17487 | 6 mm         | 10 |
| 17570 | 7 mm         | 10 |
| 17571 | 8 mm         | 10 |
| 17572 | 9 mm         | 10 |
| 17573 | 10 mm        | 10 |
| 17574 | 11 mm        | 10 |
| 17575 | 12 mm        | 10 |
| 17576 | 13 mm        | 10 |
| 17577 | 14 mm        | 10 |
| 17578 | 15 mm        | 10 |
| 17579 | 16 mm        | 10 |
| 17580 | 17 mm        | 10 |
| 17581 | 18 mm        | 10 |
| 17582 | 19 mm        | 10 |
| 17488 | 20 mm        | 10 |

| Nu.   | specificație |    |
|-------|--------------|----|
| 17489 | 21 mm        | 10 |
| 17583 | 22 mm        | 10 |
| 17490 | 23 mm        | 10 |
| 17584 | 24 mm        | 10 |
| 17491 | 25 mm        | 10 |
| 17492 | 26 mm        | 10 |
| 17585 | 27 mm        | 10 |
| 17493 | 28 mm        | 10 |
| 17494 | 29 mm        | 10 |
| 17586 | 30 mm        | 10 |
| 17587 | 32 mm        | 10 |
| 17495 | 33 mm        | 10 |
| 17496 | 34 mm        | 10 |
| 17589 | 36 mm        | 10 |

**FESTA**

## CHEIE COMBINATA CU ARTICULATIE

CrV 72T



| Nu.   | specificație |    |
|-------|--------------|----|
| 17628 | 8 mm         | 10 |
| 17622 | 10 mm        | 10 |
| 17623 | 13 mm        | 10 |
| 17624 | 14 mm        | 10 |
| 17629 | 15 mm        | 10 |
| 17630 | 16 mm        | 5  |

| Nu.   | specificație |    |
|-------|--------------|----|
| 17625 | 17 mm        | 10 |
| 17631 | 18 mm        | 10 |
| 17626 | 19 mm        | 10 |
| 17632 | 21 mm        | 5  |
| 17633 | 22 mm        | 5  |

**FESTA**

## CHEIE COMBINATA CU CLICHER

CrV 72T



| Nu.   | specificație |    |
|-------|--------------|----|
| 17660 | 6 mm         | 10 |
| 17676 | 7 mm         | 10 |
| 17661 | 8 mm         | 10 |
| 17662 | 9 mm         | 10 |
| 17663 | 10 mm        | 10 |
| 17664 | 11 mm        | 10 |
| 17665 | 12 mm        | 10 |
| 17666 | 13 mm        | 10 |
| 17667 | 14 mm        | 10 |
| 17668 | 15 mm        | 10 |

| Nu.   | specificație |    |
|-------|--------------|----|
| 17669 | 16 mm        | 10 |
| 17670 | 17 mm        | 10 |
| 17671 | 18 mm        | 10 |
| 17672 | 19 mm        | 10 |
| 17674 | 21 mm        | 5  |
| 17675 | 22 mm        | 5  |
| 17677 | 24 mm        | 5  |
| 17678 | 27 mm        | 5  |
| 17679 | 30 mm        | 5  |
| 17683 | 32 mm        | 5  |

**FESTA**

## CHEI FIXE

DIN 895



| Nu.   | specificație |    |
|-------|--------------|----|
| 17460 | 6 x 7 mm     | 10 |
| 17461 | 8 x 9 mm     | 10 |
| 17462 | 8 x 10 mm    | 10 |
| 17463 | 10 x 11 mm   | 10 |
| 17481 | 10 x 13 mm   | 10 |
| 17464 | 12 x 13 mm   | 10 |
| 17465 | 14 x 15 mm   | 10 |
| 17467 | 13 x 17 mm   | 10 |
| 17482 | 14 x 17 mm   | 10 |
| 17468 | 16 x 17 mm   | 10 |

| Nu.   | specificație |    |
|-------|--------------|----|
| 17469 | 17 x 19 mm   | 10 |
| 17470 | 18 x 19 mm   | 10 |
| 17483 | 19 x 22 mm   | 10 |
| 17484 | 19 x 24 mm   | 10 |
| 17471 | 20 x 22 mm   | 10 |
| 17472 | 24 x 27 mm   | 10 |
| 17486 | 21 x 23 mm   | 10 |
| 17480 | 28 x 30 mm   | 10 |
| 17473 | 30 x 32 mm   | 10 |
| 17485 | 36 x 41 mm   | 10 |

**FESTA**

## CHEI INELARE COTITE

CrV DIN 838



| Nu.   | specificație |    |
|-------|--------------|----|
| 17605 | 6 x 7 mm     | 10 |
| 17606 | 8 x 9 mm     | 10 |
| 17607 | 8 x 10 mm    | 10 |
| 17608 | 10 x 11 mm   | 10 |
| 17609 | 12 x 13 mm   | 10 |
| 17611 | 13 x 16 mm   | 10 |
| 17612 | 13 x 17 mm   | 10 |

| Nu.   | specificație |    |
|-------|--------------|----|
| 17610 | 14 x 15 mm   | 10 |
| 17613 | 16 x 17 mm   | 10 |
| 17614 | 18 x 19 mm   | 10 |
| 17615 | 20 x 22 mm   | 10 |
| 17616 | 24 x 27 mm   | 10 |
| 17617 | 30 x 32 mm   | 10 |

**FESTA**

## CHEI FIXE

CrV DIN 3110



| Nu.   | specificație |    |
|-------|--------------|----|
| 17761 | 14 x 15 mm   | 10 |
| 17769 | 20 x 22 mm   | 10 |

**FESTA**

## CHEI COMBinate

CrV DIN 3113



| Nu.   | specificație |    |
|-------|--------------|----|
| 17788 | 14 mm        | 10 |
| 17795 | 21 mm        | 10 |
| 17806 | 33 mm        | 10 |

**FESTA**

CHEIE CU CLICHET SET

8-9-10-11-12-13-14-15-16-17-18-19 mm



| Nu.   | specificatie |   |
|-------|--------------|---|
| 17619 |              | 1 |



NEW

**FESTA**

CHEI

Cr-Mo



12-13-14-15 mm

16-17-18-19 mm

| Nu.   | specificatie               |   |
|-------|----------------------------|---|
| 17685 | 12-13-14-15-16-17-18-19 mm | 1 |



**FESTA**

MÜA. MARKOLAT CHEI REGLABILE

CrV



| Nu.   | rozsah    | délka  |   |
|-------|-----------|--------|---|
| 17197 | 0 - 29 mm | 200 mm | 1 |
| 17198 | 0 - 33 mm | 250 mm | 1 |
| 17199 | 0 - 38 mm | 300 mm | 1 |



CHEI REGLABILE

| Nu.   | rozsah    | délka  |   |
|-------|-----------|--------|---|
| 17200 | 0 - 24 mm | 200 mm | 6 |
| 17201 | 0 - 30 mm | 250 mm | 6 |
| 17202 | 0 - 34 mm | 300 mm | 6 |



**FESTA**



**FESTA**

SET CHEI FIXE

CrV DIN 3110



| Nu.   | specificatie   |   |
|-------|--|---|
| 17506 | 6 buc · 6 x 7, 8 x 9, 10 x 11, 12 x 13, 14 x 15, 16 x 17                   | 1 |
| 17508 | 8 buc · 6 x 7, 8 x 9, 10 x 11, 12 x 13, 14 x 15, 16 x 17, 18 x 19, 20 x 22 | 1 |



**FESTA**

SET CHEI COMBINE

CrV DIN 3113



| Nu.   | specificatie   |   |
|-------|--|---|
| 17526 | 6 buc · 10 x 10, 11 x 11, 13 x 13, 14 x 14, 16 x 16, 17 x 17                 | 1 |
| 17528 | 8 buc · 8 x 8, 10 x 10, 11 x 11, 13 x 13, 14 x 14, 16 x 16, 17 x 17, 19 x 19 | 1 |



**FESTA**

SET CHEI INELARE COTITE

8x CrV DIN 838



| Nu.   | specificatie   |   |
|-------|--|---|
| 17539 | 6 x 7, 8 x 9, 10 x 11, 12 x 13, 14 x 15, 16 x 17, 18 x 19, 20 x 22 | 1 |



**FESTA**

SET CHEI COMBIMATE



CrV

DIN 3113



| Nu.   | specificatie   |    |
|-------|--|----|
| 17532 | 12 buc · 8 x 8, 9 x 9, 10 x 10, 11 x 11, 13 x 13, 14 x 14, 16 x 16, 17 x 17, 18 x 18, 19 x 19, 21 x 21, 22 x 22  | 10 |
| 17533 | 18 buc · 6 x 6, 7 x 7, 8 x 8, 9 x 9, 10 x 10, 11 x 11, 12 x 12, 13 x 13, 14 x 14, 15 x 15, 16 x 16, 17 x 17, 18 x 18, 19 x 19, 20 x 20, 21 x 21, 22 x 22, 24 x 24  | 1  |
| 17534 | 25 buc · 6 x 6, 7 x 7, 8 x 8, 9 x 9, 10 x 10, 11 x 11, 12 x 12, 13 x 13, 14 x 14, 15 x 15, 16 x 16, 17 x 17, 18 x 18, 19 x 19, 20 x 20, 21 x 21, 22 x 22, 23 x 23, 24 x 24, 25 x 25, 26 x 26, 27 x 27, 28 x 28, 30 x 30, 32 x 32 | 4  |

**FESTA**

CHEI COMBIMATE CU CLICHET



CrV

72T

7x

| Nu.   | specificatie              |   |
|-------|---------------------------|---|
| 17620 | 8, 10, 12, 13, 14, 17, 19 | 5 |

**FESTA**

CHEI COMBIMATE CU CLICHET CU ARTICULATIE



CrV

72T

7x

| Nu.   | specificatie               |   |
|-------|----------------------------|---|
| 17621 | 10, 12, 13, 14, 15, 17, 19 | 5 |

**FESTA**

SET CHEI FIXE



CrV

DIN 3110

12x



| Nu.   | specificatie   |   |
|-------|--|---|
| 17512 | 6 x 7, 8 x 9, 10 x 11, 12 x 13, 14 x 15, 16 x 17, 18 x 19, 20 x 22, 21 x 23, 24 x 27, 25 x 28, 30 x 32 | 1 |

**FESTA**

SET CHEI TUBULARE



CrV

7x

| Nu.   | specificatie  |    |
|-------|---|----|
| 17501 | 6 x 7, 8 x 9, 10 x 11, 12 x 13, 14 x 15, 16 x 17, 18 x 19 | 20 |
| 17640 | levier pentru tubulare · 135 mm                           | 50 |

**FESTA**

SET CHEI FIXE



DIN 895



| Nu.   | specificatie  |   |
|-------|---|---|
| 17475 | 8 buc · 6 x 7, 8 x 9, 10 x 11, 12 x 13, 14 x 15, 16 x 17, 18 x 19, 20 x 22                                      | 5 |
| 17476 | 12 buc · 6 x 7, 8 x 9, 10 x 11, 12 x 13, 14 x 15, 16 x 17, 18 x 19, 20 x 22, 21 x 23, 24 x 27, 28 x 30, 30 x 32 | 3 |

**FESTA**

CHEI TUBULARE



CrV

| Nu.   | specificatie |    | Nu.   | specificatie |    |
|-------|--------------|----|-------|--------------|----|
| 17650 | 6 x 7 mm     | 10 | 17655 | 16 x 17 mm   | 10 |
| 17651 | 8 x 9 mm     | 10 | 17645 | 16 x 18 mm   | 10 |
| 17642 | 8 x 10 mm    | 10 | 17653 | 16 x 21 mm   | 10 |
| 17652 | 10 x 11 mm   | 10 | 17656 | 18 x 19 mm   | 10 |
| 17643 | 12 x 13 mm   | 10 | 17657 | 19 x 22 mm   | 10 |
| 17654 | 14 x 15 mm   | 10 | 17659 | 22 x 24 mm   | 10 |
| 17644 | 14 x 17 mm   | 10 | 17658 | 24 x 27 mm   | 10 |



CHEI LA POLIZOR UNGHIULAR



| Nu.   | specificatie |    |
|-------|--------------|----|
| 20967 | 200 mm       | 15 |



CHEI LA POLIZOR UNGHIULAR



| Nu.   | specificatie |   |
|-------|--------------|---|
| 20968 | 200 mm       | 1 |



**FESTA**

INELARA  
CU CLICHET



| Nu.   | specificatie |   |
|-------|--------------|---|
| 17452 | 19 x 22 mm   | 2 |



**FESTA**

INELARA  
CU CLICHET

| Nu.   | specificatie |    |
|-------|--------------|----|
| 17451 | 18 mm        | 10 |
| 17450 | 19 mm        | 10 |



**FESTA**

CLICHET DINAMOMETRIC REGLABIL

| Nu.   | specificatie      |   |
|-------|-------------------|---|
| 17203 | 1/4" 5 - 25 Nm    | 1 |
| 17204 | 1/2" 19 - 110 Nm  | 1 |
| 17205 | 1/2" 42 - 210 Nm  | 1 |
| 17206 | 3/4" 140 - 700 Nm | 1 |



**FESTA**

made by **HENITON**

CAPETE CHEI  
TUBULARE

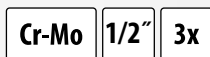

| Ĉ.p.  | specificatie |   |
|-------|--------------|---|
| 17338 | 21 mm        | 5 |



CHEIE IN CRUCE  
PENTRU ROTI



| Nu.   | specificatie          |    |
|-------|-----------------------|----|
| 17600 | 17, 19, 22 mm, 13/16" | 16 |

CHEIE IN CRUCE  
PENTRU ROTI



| Nu.   | specificatie  |    |
|-------|---------------|----|
| 17601 | 17, 19, 21 mm | 20 |

COARBA  
TELESCOPICA  
ROTI

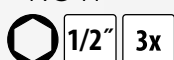

| Nu.   | specificatie           |    |
|-------|------------------------|----|
| 17603 | 17 x 19 mm, 21 x 23 mm | 20 |

CHEIE  
ARTICULATA BUJII  
CU CLICHET



| Nu.   | specificatie |   |
|-------|--------------|---|
| 17261 | 16 mm        | 1 |
| 17262 | 21 mm        | 1 |

**FESTA**

CHEIE FIXA

CrV



| Nu.   | specificație |        |   |
|-------|--------------|--------|---|
| 17680 | 19 - 51 mm   | 165 mm | 5 |
| 17681 | 32 - 76 mm   | 216 mm | 5 |
| 17682 | 51 - 121 mm  | 267 mm | 5 |



EXTRACTOR  
PENTRU  
LAGĂRE



| Nu.   | max. Ø   | adâncime   |   |
|-------|----------|------------|---|
| 23734 | Ø 100 mm | 50-95 mm   | 1 |
| 23735 | Ø 150 mm | 100-150 mm | 1 |
| 23736 | Ø 200 mm | 110-190 mm | 1 |



EXTRACTOR  
PENTRU  
LAGĂRE



| Nu.   | max. Ø   | adâncime   |   |
|-------|----------|------------|---|
| 23730 | Ø 100 mm | 50-95 mm   | 2 |
| 23731 | Ø 150 mm | 100-150 mm | 2 |
| 23732 | Ø 200 mm | 110-190 mm | 2 |



**FESTA**

CHEIE IMBUS  
UNIVERSALA

CrV 1/2"



| Nu.   | specificație   |    |
|-------|----------------|----|
| 17455 | pro răcnu 1/2" | 10 |

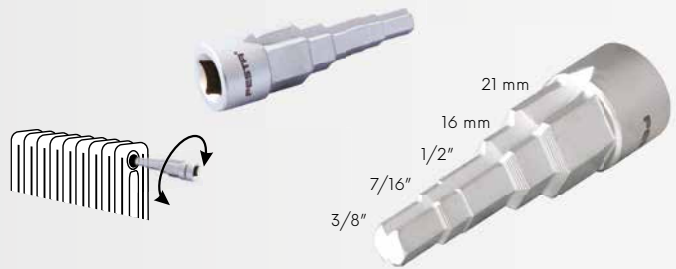

CHEIE AERISIRE CALORIFER

CHEIE AERISIRE CALORIFER  
CU REZERVOR

2x



| Nu.   | specificație |   |
|-------|--------------|---|
| 17454 | 5 x 5 mm     | 1 |

| Nu.   | specificație |   |
|-------|--------------|---|
| 17459 | 50 ml        | 1 |

**FESTA**

CHEIE UNIVERSALĂ PENTRU  
TABLOURI DE DISTRIBUȚIE

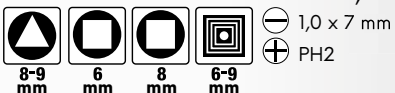

| Nu.   | specificație |   |
|-------|--------------|---|
| 17458 |              | 1 |



**FESTA**

CHEIE UNIVERSALĂ PENTRU  
TABLOURI DE DISTRIBUȚIE

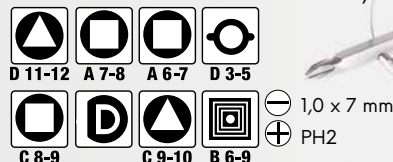

| Nu.   | specificație |    |
|-------|--------------|----|
| 17456 |              | 50 |





**ERGONOMIC handle**

STANDARD +30% FESTA

CrV om vanadium  
HRC 58-62 duritate  
maner ergonomic din cauciu TPE  
tratata prin inductie



**CLESTE COMBAT**

| DIN 5746 | TUV GS    | Nu.   | specificatie |   |
|----------|-----------|-------|--------------|---|
| CrV      | HRC 58-62 | 17101 | 160 mm       | 6 |
|          |           | 17102 | 180 mm       | 6 |
|          |           | 17103 | 200 mm       | 6 |



**CLESTE SFIC**

| DIN 5749 | TUV GS | CrV | HRC 58-62 | ERGO HANDLE | Nu.   | specificatie |   |
|----------|--------|-----|-----------|-------------|-------|--------------|---|
|          |        |     |           |             | 17148 | 180 mm       | 6 |



**CLESTE SFIC**

| DIN 5749 | TUV GS | CrV | HRC 58-62 | ERGO HANDLE | Nu.   | specificatie |   |
|----------|--------|-----|-----------|-------------|-------|--------------|---|
|          |        |     |           |             | 17104 | 160 mm       | 6 |
|          |        |     |           |             | 17105 | 180 mm       | 6 |



**CLESTE CU FALCI ASCUTITE LUNGI**

| DIN 5745 | TUV GS | CrV | HRC 58-62 | ERGO HANDLE | Nu.   | specificatie |   |
|----------|--------|-----|-----------|-------------|-------|--------------|---|
|          |        |     |           |             | 17140 | 160 mm       | 6 |
|          |        |     |           |             | 17142 | 200 mm       | 6 |



**CLESTE CU FALCI ASCUTITE LUNGI**

| DIN 5749 | TUV GS | CrV | HRC 58-62 | ERGO HANDLE | Nu.   | specificatie |   |
|----------|--------|-----|-----------|-------------|-------|--------------|---|
|          |        |     |           |             | 17145 | 160 mm       | 6 |
|          |        |     |           |             | 17146 | 200 mm       | 6 |



# FESTA





**FESTA**

COMBINAT CLESTE

| <b>DIN 5746</b> |              |   |  |  |
|-----------------|--------------|---|--|--|
| Nu.             | specificatie |   |  |  |
| 17001           | 160 mm       | 6 |  |  |
| 17002           | 180 mm       | 6 |  |  |
| 17003           | 200 mm       | 6 |  |  |



**FESTA**

CLESTE SFIC

| <b>DIN 5749</b> |              |   |  |  |
|-----------------|--------------|---|--|--|
| Nu.             | specificatie |   |  |  |
| 17004           | 160 mm       | 6 |  |  |
| 17005           | 180 mm       | 6 |  |  |



**FESTA**

CLESTE SFIC

| <b>DIN 5749</b> |              |   |  |  |
|-----------------|--------------|---|--|--|
| Nu.             | specificatie |   |  |  |
| 17108           | 180 mm       | 6 |  |  |



**FESTA**

CLESTI DE TAIERE

| <b>DIN 5748</b> |              |   |  |  |
|-----------------|--------------|---|--|--|
| Nu.             | specificatie |   |  |  |
| 17110           | 160 mm       | 6 |  |  |



**FESTA**

CLESTE CU FALCI ASCUTITE LUNGI

| <b>DIN 5745</b> |              |   |  |  |
|-----------------|--------------|---|--|--|
| Nu.             | specificatie |   |  |  |
| 17006           | 160 mm       | 6 |  |  |
| 17011           | 200 mm       | 6 |  |  |



**FESTA**

CLESTE CU FALCI ASCUTITE LUNGI

| <b>DIN 5745</b> |              |   |  |  |
|-----------------|--------------|---|--|--|
| Nu.             | specificatie |   |  |  |
| 17007           | 160 mm       | 6 |  |  |
| 17008           | 200 mm       | 6 |  |  |



**FESTA**

CLESTE CU FALCI PLATE LUNGI

| <b>DIN 5746</b> |              |   |  |  |
|-----------------|--------------|---|--|--|
| Nu.             | specificatie |   |  |  |
| 17009           | 160 mm       | 6 |  |  |



**FESTA**

CLESTE CU FALCI ROTUNDE LUNGI

| <b>DIN 5745</b> |              |   |  |
|-----------------|--------------|---|--|
| Nu.             | specificatie |   |  |
| 17010           | 160 mm       | 6 |  |



**FESTA**

CLESTE DEZIZOLATOR

| <b>DIN 5744</b> |              |   |  |
|-----------------|--------------|---|--|
| Nu.             | specificatie |   |  |
| 17024           | 160 mm       | 6 |  |



COMBINAT CLESTE

| <b>DIN 5746</b> |              |   |  |
|-----------------|--------------|---|--|
| Nu.             | specificatie |   |  |
| 17094           | 160 mm       | 6 |  |
| 17095           | 180 mm       | 6 |  |
| 17096           | 200 mm       | 6 |  |



CLESTE SFIC

| <b>DIN 5749</b> |              |   |  |
|-----------------|--------------|---|--|
| Nu.             | specificatie |   |  |
| 17097           | 160 mm       | 6 |  |
| 17098           | 180 mm       | 6 |  |



CLESTE CU FALCI ASCUTITE LUNGI

| <b>DIN 5745</b> |              |   |  |
|-----------------|--------------|---|--|
| Nu.             | specificatie |   |  |
| 17099           | 160 mm       | 6 |  |
| 17100           | 200 mm       | 6 |  |



VDE CLESTE COMBINAT

1000 V IEC/EN60900:2004

DIN 5746

CrV

HRC 58-62



| Nu.   | specificație |   |
|-------|--------------|---|
| 17125 | 160 mm       | 6 |
| 17126 | 180 mm       | 6 |
| 17127 | 200 mm       | 6 |



VDE CLESTE SFIC

1000 V IEC/EN60900:2004

DIN 5749

CrV

HRC 58-62



| Nu.   | specificație |   |
|-------|--------------|---|
| 17128 | 160 mm       | 6 |



VDE CLESTE DE TAIAT CABLURI DE SARMA

1000 V IEC/EN60900:2004

CrV

HRC 58-62



| Nu.   | specificație |   |
|-------|--------------|---|
| 17130 | 160 mm       | 6 |



VDE CLESTE CU FALCI ASCUTITE LUNGI

1000 V IEC/EN60900:2004

DIN 5745

CrV

HRC 58-62



| Nu.   | specificație |   |
|-------|--------------|---|
| 17133 | 160 mm       | 6 |



VDE CLESTE CU FALCI ASCUTITE LUNGI

1000 V IEC/EN60900:2004

DIN 5745

CrV

HRC 58-62



| Nu.   | specificație |   |
|-------|--------------|---|
| 17135 | 160 mm       | 6 |



VDE CLESTE CU FALCI ROTUNDE LUNGI

1000 V IEC/EN60900:2004

DIN 5745

CrV

HRC 58-62



| Nu.   | specificație |   |
|-------|--------------|---|
| 17137 | 160 mm       | 6 |



VDE CLESTE DEZIZOLATOR

1000 V IEC/EN60900:2004

CrV

DIN 5744



| Nu.   | specificație |   |
|-------|--------------|---|
| 17138 | 160 mm       | 6 |



CLEȘTE PENTRU CABLURI FINE

max Ø 0,2 - 2,1 mm

CrV

| Nu.   | specificație |    |
|-------|--------------|----|
| 17047 | 140 mm       | 10 |



CLEȘTE PENTRU CABLURI FINE

0,75; 1,0; 1,5; 2,5; 4,0; 6,0mm<sup>2</sup>

CrV

| Nu.   | specificație |   |
|-------|--------------|---|
| 17087 | 145 mm       | 1 |



CLESTE AUTOMAT PENTRU DEZIZOLARE CABLURI

0,5 - 6 mm<sup>2</sup>  
190 mm



| Nu.   | specificație |   |
|-------|--------------|---|
| 17178 |              | 1 |



CLESTE AUTOMAT PENTRU DEZIZOLARE CABLURI

| Nu.   | specificație    |    |
|-------|-----------------|----|
| 17180 | Ø 0,75 - 2,5 mm | 12 |



CLESTE DE DEZIZOLAT SI TAIAT

| Nu.   | specificație    |    |
|-------|-----------------|----|
| 17181 | Ø 0,60 - 2,6 mm | 10 |

**NEW**



**FESTA**

**STRIPPER CABLU**

· Ø 0,2-4 mm



| Nu.   | Specificație |   |
|-------|--------------|---|
| 16205 | 125 mm       | 1 |

**FESTA**

**STRIPPER CABLU**

| AWG | mm <sup>2</sup> |
|-----|-----------------|
| 10  | 6,0             |
| 12  | 4,0             |
| 14  | 2,5             |
| 16  | 1,5             |
| 18  | 1,0             |
| 20  | 0,5             |

· Cablu coaxial RG6/59  
· cablu de joasă tensiune Ø 8 - 13 mm



| Nu.   | Specificație |    |
|-------|--------------|----|
| 16202 | 125 mm       | 10 |



**FESTA**  
INDUSTRY

**CLESTE PENTRU SERTIZAT**

**6x**



| Nu.   | Specificație |   |
|-------|--------------|---|
| 18445 |              | 1 |



· AWG 22-18/16-14/12-10  
· DIN 0,5-1,0/1,5-2,5/4-6mm<sup>2</sup>

· AWG 20-16/16-14/12-10/8  
· DIN 0,5-1,0/1,5-2,5/4-6/10mm<sup>2</sup>

· AWG 20-18/16-14/12-10  
· DIN 0,5-1,0/1,5-2,5/4-6mm<sup>2</sup>

· AWG 20/18/17/16/14/12  
· DIN 0,5/0,75/1,0/1,5/2,5/4,0mm<sup>2</sup>

· AWG 10/8/6  
· DIN 6/10/16mm<sup>2</sup>

**NEW**



**FESTA**  
INDUSTRY

**CLESTE PENTRU SERTIZAT**

Nu. Specificație

16206



1



· AWG 10-22  
· 0,5-0,6mm<sup>2</sup>

· AWG 10-22  
· 0,5-0,6mm<sup>2</sup>

· AWG 10-22  
· 0,5-0,6mm<sup>2</sup>

· dezizolat · AWG 10-24  
· 0,2-0,6mm<sup>2</sup>

**NEW**



**FESTA**  
INDUSTRY

**CLESTE PENTRU SERTIZAT**

Nu. Specificație

16208



1



· 1,5; 2,5; 6,0mm<sup>2</sup>

· 1,5; 2,5; 6,0mm<sup>2</sup>

· dezizolat · 0,75; 1,0; 1,5; 2,5; 4,0; 6,0mm<sup>2</sup>

· tăiere cu șuruburi · M2,6; M3; M3,5; M4; M5

**NEW**



**FESTA**

**CLEȘTE MULTIFUNCȚIONALE**

· 9 funcție  
· Caz

**CrV**

| Nu.   | specificație |    |
|-------|--------------|----|
| 16232 |              | 12 |



**FESTA**

**SET CLEȘTI MINI**

**4x**

| Nu.   | specificație |   |
|-------|--------------|---|
| 17040 |              | 6 |



**FESTA**

**COMBINAT CLEȘTE MINI**

| Nu.   | specificație |    |
|-------|--------------|----|
| 17041 | 110 mm       | 12 |



**FESTA**

**CLEȘTE SFIC MINI**

| Nu.   | specificație |    |
|-------|--------------|----|
| 17042 | 110 mm       | 12 |



**FESTA**

**CLEȘTE MINI**

| Nu.   | specificație |    |
|-------|--------------|----|
| 17043 | 100 mm       | 12 |



**FESTA**

**CLEȘTE CU FALCI ASCUTITE LUNGI**

| Nu.   | specificație |    |
|-------|--------------|----|
| 17044 | 120 mm       | 12 |



**FESTA**

**CLEȘTE MINI ROTIRE**

| Nu.   | specificație |    |
|-------|--------------|----|
| 17045 | 120 mm       | 12 |



**CLEȘTE SIGURANTA ZEGER**

| Nu.   | specificație |    |
|-------|--------------|----|
| 17025 | set          | 10 |



**FESTA**

**CLEȘTE SIGURANTA ZEGER DREPT**

| Nu.   | specificație       |   |
|-------|--------------------|---|
| 17190 | 180 mm de interior | 6 |
| 17191 | 180 mm de exterior | 6 |



**FESTA**

**CLEȘTE SIGURANTA ZEGER INDOIT**

| Nu.   | specificație       |    |
|-------|--------------------|----|
| 17192 | 180 mm de interior | 15 |
| 17193 | 180 mm de exterior | 15 |



**FESTA**

**CLEȘTE DE GARD  
MULTIFUNCȚIONAL**

Pentru gard

**CrV**



| Nu.   | specificație |
|-------|--------------|
| 17109 | 270 mm       |



4



**CLEȘTE MENGHINA**

| Ț.p.  | Specifikație |
|-------|--------------|
| 17150 | 220 mm       |



1



**CLEȘTE MENGHINA**

| Ț.p.  | Specifikație |
|-------|--------------|
| 17151 | 225 mm       |



1



**CLEȘTE MENGHINA**

| Ț.p.  | specifikație |
|-------|--------------|
| 17034 | 220 mm       |



5



**FESTA**

**CLEȘTE MENGHINA**

| Ț.p.  | specifikație |
|-------|--------------|
| 17036 | 270 mm       |



5



**CLEȘTE MENGHINA**

| Ț.p.  | specifikație |
|-------|--------------|
| 17035 | 220 mm       |



10



**FESTA**

**CLEȘTE MENGHINA**

| Ț.p.  | specifikație |
|-------|--------------|
| 17023 | 220 mm       |



6

**FESTA**

**CLEȘTE REGLABIL 45°, S**

**CrV**



| Nu.   | specificație  |
|-------|---------------|
| 17067 | 1"   330 mm   |
| 17068 | 1,5"   420 mm |
| 17069 | 2"   540 mm   |



**FESTA**

**CLEȘTE REGLABIL**

**CrV**

| Nu.   | specificație |
|-------|--------------|
| 17063 | 230 mm       |
| 17064 | 300 mm       |



**FESTA**

**CLEȘTE REGLABIL 90°**

**CrV**



| Nu.   | specificație  |
|-------|---------------|
| 17075 | 1"   330 mm   |
| 17076 | 1,5"   420 mm |
| 17077 | 2"   540 mm   |



**CLEȘTE REGLABIL**

| Nu.   | specificație |
|-------|--------------|
| 17065 | 260 mm       |
| 17066 | 300 mm       |

**FESTA**

**CHEIE REGLABILĂ 90°**

**CrV**



| Nu.   | specificație  |
|-------|---------------|
| 17070 | 2,5"   355 mm |
| 17071 | 3"   455 mm   |
| 17072 | 3,5"   610 mm |



**FESTA**

CLESTE PAPAGAL



CrV

| Nu.   | specificație |           | rozzah țelisti |   |
|-------|--------------|-----------|----------------|---|
| 16500 | 180 mm       | 0 - 40 mm | 6              | 1 |
| 16501 | 250 mm       | 0 - 52 mm | 6              | 1 |
| 16502 | 300 mm       | 0 - 68 mm | 6              | 1 |

**FESTA**

CLESTE PAPAGAL



CrV

| Nu.   | specificație | rozzah țelisti |   |
|-------|--------------|----------------|---|
| 17059 | 180 mm       | 0 - 30 mm      | 6 |
| 17061 | 250 mm       | 0 - 30 mm      | 6 |
| 17062 | 300 mm       | 0 - 40 mm      | 6 |
| 17080 | 400 mm       | 0 - 84 mm      | 4 |

**FESTA**

CLESTE PAPAGAL



CrV

| Nu.   | specificație | rozzah țelisti |   |
|-------|--------------|----------------|---|
| 17084 | 250 mm       | 0 - 30 mm      | 6 |

**FESTA**

CLESTE PAPAGAL



CrV

· large range of jaws

| Nu.   | specificație | rozzah țelisti |   |
|-------|--------------|----------------|---|
| 17086 | 250 mm       | 0 - 50 mm      | 6 |

**FESTA**

CLESTE PAPAGAL



CrV

| Nu.   | specificație | rozzah țelisti |   |
|-------|--------------|----------------|---|
| 17081 | 180 mm       | 0 - 30 mm      | 6 |
| 17014 | 250 mm       | 0 - 30 mm      | 6 |
| 17082 | 300 mm       | 0 - 50 mm      | 6 |

**FESTA**

CLESTE PAPAGAL



CrV

| Nu.   | specificație | rozzah țelisti |   |
|-------|--------------|----------------|---|
| 17079 | 250 mm       | 0 - 50 mm      | 6 |

**FESTA**

CLESTE PAPAGAL



CrV

| Nu.   | specificație | rozzah țelisti |    |
|-------|--------------|----------------|----|
| 17012 | 250 mm       | 0 - 40 mm      | 6  |
| 17060 | 300 mm       | 0 - 50 mm      | 10 |

**FESTA**

CLESTE PAPAGAL



CrV

| Nu.   | specificație | rozzah țelisti |   |
|-------|--------------|----------------|---|
| 17013 | 250 mm       | 0 - 30 mm      | 6 |
| 17033 | 300 mm       | 0 - 50 mm      | 6 |

PROTECTIE PLASTIC  
CLESTE PAPAGAL



· suitable for 17061, 17079

| Nu.   | specificație |   |
|-------|--------------|---|
| 17085 | 1 pár        | 1 |

**FESTA**

CLESTE DE TAIAT CABLURI  
DE SARMA



CrV

max. Ø  
6 mm

| Ĉ.p.  | specificație |   |
|-------|--------------|---|
| 17029 | 200 mm       | 6 |

**FESTA**

CLESTI PENTRU  
FRANGHII



CrV

max. Ø  
12 mm

| Ĉ.p.  | specificație |   |
|-------|--------------|---|
| 17039 | 24'   610 mm | 8 |



**FESTA**

**CLESTI PENTRU TAIAT FIER BETON**

**Cr-Mo**



| Nu.   | specificație |                    |   |
|-------|--------------|--------------------|---|
| 17049 | 18'   450 mm | max. 6 mm < 40 HRC | 1 |

**FESTA**

**CLESTI PENTRU TAIAT FIER BETON**

**Cr-Mo**

**HRC 58-62**



| Nu.   | specificație | max. Ø drátu        |   |
|-------|--------------|---------------------|---|
| 17051 | 14'   350 mm | max. 5 mm < 45 HRC  | 1 |
| 17052 | 18'   450 mm | max. 6 mm < 45 HRC  | 1 |
| 17053 | 24'   610 mm | max. 8 mm < 45 HRC  | 1 |
| 17054 | 30'   760 mm | max. 10 mm < 45 HRC | 1 |
| 17048 | 36'   900 mm | max. 12 mm < 45 HRC | 1 |



**FESTA**

**CLESTI PENTRU TAIAT FIER BETON**

· Pentru cabluri și fire

**Cr-Mo**

**HRC 58-62**



| Nu.   | specificație | max. Ø drátu        | max. Ø lanka | max. Ø kabelu |   |
|-------|--------------|---------------------|--------------|---------------|---|
| 17055 | 14'   360 mm | max. 5 mm < 45 HRC  | max. 3,5 mm  | max. 8 mm     | 1 |
| 17056 | 18'   460 mm | max. 6 mm < 45 HRC  | max. 5 mm    | max. 10 mm    | 1 |
| 17057 | 24'   610 mm | max. 8 mm < 45 HRC  | max. 7 mm    | max. 12 mm    | 1 |
| 17058 | 30'   760 mm | max. 10 mm < 45 HRC | max. 9 mm    | max. 14 mm    | 1 |
| 17046 | 35'   900 mm | max. 12 mm < 45 HRC | max. 10 mm   | max. 16 mm    | 1 |



**FESTA**

**MINI CLESTE TAIETOR**

**Cr-Mo**

**HRC 57-62**

**max. Ø  
4 mm**



| Nu.   | specificație |                       |
|-------|--------------|-----------------------|
| 17038 | 8'   210 mm  | max. 4 mm < 30 HRC 10 |



**FESTA**

**CLESTE TAIETOR**

- fir moale: Ø 6 mm
- fir mediu dur: Ø 5 mm
- fir dur: Ø 4 mm

**CrV**



| Nu.   | Specificație |    |
|-------|--------------|----|
| 17078 | 200 mm       | 12 |



**CLESTI PENTRU TAIAT FIER BETON**



| Nu.   | specificație | max. Ø drátu        |    |
|-------|--------------|---------------------|----|
| 17028 | 14'   350 mm | max. 5 mm < 30 HRC  | 30 |
| 17020 | 18'   450 mm | max. 6 mm < 30 HRC  | 6  |
| 17021 | 24'   610 mm | max. 8 mm < 30 HRC  | 10 |
| 17022 | 30'   760 mm | max. 10 mm < 30 HRC | 5  |

**NEW**



**FESTA**  
CLESTE PENTRU CUIE

| Nu.   | specificatie |   |
|-------|--------------|---|
| 17172 | 200 mm       | 1 |



**FESTA**  
CLESTE PENTRU CUIE

| Nu.   | specificatie |    |
|-------|--------------|----|
| 17300 | 160 mm       | 1  |
| 17301 | 180 mm       | 10 |
| 17302 | 200 mm       | 6  |
| 17303 | 250 mm       | 1  |



**FESTA**  
CLESTE PENTRU SARMA

| Nu.   | specificatie |   |
|-------|--------------|---|
| 17305 | 220 mm       | 5 |
| 17306 | 250 mm       | 1 |
| 17304 | 275 mm       | 6 |



CLESTE PENTRU CUIE

| Nu.   | specificatie |   |
|-------|--------------|---|
| 17015 | 160 mm       | 6 |
| 17016 | 180 mm       | 6 |
| 17017 | 200 mm       | 6 |



CLESTE PENTRU SARMA

| Nu.   | specificatie |   |
|-------|--------------|---|
| 17019 | 220 mm       | 6 |
| 17083 | 275 mm       | 6 |



**FESTA**  
CLESTE TINICHIGIU DREPT

| Nu.   | specificatie |   |
|-------|--------------|---|
| 17089 | 150 x 215 mm | 2 |

**NEW**



**FESTA**  
CLESTE TINICHIGIU DREPT

| Nu.   | specificatie |   |
|-------|--------------|---|
| 17341 | 24 x 180 mm  | 1 |

**NEW**



**FESTA**  
CLESTE TINICHIGIU 45°

| Nu.   | specificatie |   |
|-------|--------------|---|
| 17342 | 24 x 180 mm  | 1 |



**FESTA**  
CLESTE TINICHIGIU DREPT

| Nu.   | specificatie |   |
|-------|--------------|---|
| 17093 | 95 x 270 mm  | 6 |



**FESTA**  
CLESTE TINICHIGIU 45°

| Nu.   | specificatie |    |
|-------|--------------|----|
| 17091 | 50 x 280 mm  | 10 |



**FESTA**  
CLESTE TINICHIGIU 90°

| Nu.   | specificatie |    |
|-------|--------------|----|
| 17092 | 50 x 260 mm  | 10 |



**FESTA**  
CLESTE TINICHIGIU DREPT

| Nu.   | specificatie |    |
|-------|--------------|----|
| 17090 | 50 x 280 mm  | 10 |



**FESTA**

FOARFECA PENTRU TABLA

**CrV**



| Nu.   | specificație |   |
|-------|--------------|---|
| 17170 | 50   250 mm  | 6 |



FOARFECA PENTRU TABLA

**CrV**



| Nu.   | specificație |   |
|-------|--------------|---|
| 17167 | 70   300 mm  | 5 |



FOARFECA PENTRU TABLA

**CrV**



| Nu.   | specificație |   |
|-------|--------------|---|
| 17165 | 60   250 mm  | 5 |



FOARFECA PENTRU TABLA

**CrV**



| Nu.   | specificație |   |
|-------|--------------|---|
| 17169 | 35   250 mm  | 5 |

**FESTA**

FOARFECA PENTRU TABLA LUNG



**Cr-Mo** HRC 58-62

| Nu.   | specificație      |   |
|-------|-------------------|---|
| 17113 | drept 80   300 mm | 6 |

**FESTA**

FOARFECA PENTRU TABLA

**Cr-Mo** HRC 58-62



| Nu.   | specificație        |   |
|-------|---------------------|---|
| 17111 | drept 40   250 mm   | 6 |
| 17116 | dreapta 40   250 mm | 6 |
| 17121 | stanga 40   250 mm  | 6 |

**FESTA**

FOARFECA PENTRU TABLA

**Cr-Mo** HRC 58-62



| Nu.   | specificație      |   |
|-------|-------------------|---|
| 17112 | rovne 40   260 mm | 6 |
| 17117 | pravé 40   260 mm | 6 |
| 17122 | levé 40   260 mm  | 6 |



ADAPTOR PENTRU TAIAT TABLA



| Nu.   | specificatie |   |
|-------|--------------|---|
| 20364 |              | 1 |



FOARFECA PENTRU TABLA



| Nu.   | specificatie |   |
|-------|--------------|---|
| 17186 | 265 mm       | 6 |



GHILOTINA MANUALA

|  | 17175                   | 17177              |
|--|-------------------------|--------------------|
|  | max. 4mm                | 5mm                |
|  | max. $\varnothing$ 10mm | $\varnothing$ 12mm |
|  | max. 8x8mm              | 10x10mm            |

| Nu.   | specificatie |   |
|-------|--------------|---|
| 17175 | 150 mm       | 1 |
| 17177 | 250 mm       | 1 |

ADAPTOR PENTRU TAIAT TABLA

maximális lemezvastagság / grosime max tabla:

- 1,8 mm - acél / oțel
- 1,2 mm - Rozsdamentes / inoxidabil
- 2 mm - műanyag, alumínium, réz / plastic, aluminu, cupru



| Nu.   | specificatie |   |
|-------|--------------|---|
| 20363 |              | 5 |



FOARFECA

INOX

PVC



| Č.p.  | specifikace |    |
|-------|-------------|----|
| 16420 | 60   200 mm | 12 |



FOARFECA

INOX

PVC



| Č.p.  | specifikace |    |
|-------|-------------|----|
| 17159 | 65   220 mm | 12 |



FOARFECA

INOX

PVC



| Č.p.  | specifikace |    |
|-------|-------------|----|
| 17158 | 50   150 mm | 10 |



FOARFECA

INOX

PVC



| Č.p.  | specifikace |    |
|-------|-------------|----|
| 17160 | 70   210 mm | 12 |



FOARFECA

INOX

| Č.p.  | specifikace |    |
|-------|-------------|----|
| 16405 | 14 cm       | 24 |
| 16406 | 17 cm       | 24 |
| 16407 | 19 cm       | 24 |
| 16408 | 21,5 cm     | 12 |



FOARFECA

3x INOX

| Č.p.  | specifikace |    |
|-------|-------------|----|
| 16401 | 3 ks        | 48 |



FESTA

CLESTE DE PERFORAT



| Nu.   | specificație                |    |
|-------|-----------------------------|----|
| 17185 | Ø 2; 2,5; 3; 3,5; 4; 4,5 mm | 12 |



FESTA

FOARFECA PENTRU PROFILE

· lplinte, profile, tevi



| Nu.   | specificație                               |   |
|-------|--|---|
| 17050 | 60   250 mm      ø 17 mm, ø 20 mm, ø 27 mm | 8 |



CLESTE PENTRU CONECTARE PROFILE



| Nu.   | specificație |   |
|-------|--------------|---|
| 17187 | 350 mm       | 6 |



CLESTE PENTRU CONECTARE PROFILE



| Nu.   | specificație |    |
|-------|--------------|----|
| 17188 | 250 mm       | 12 |



DISPOZITIV DE NITUIT PENTRU PROFILE



| Nu.   | specificație |    |
|-------|--------------|----|
| 17189 | 255 mm       | 12 |





# FESTA

**FESTA**

CLESTE NITURI

Cr-Mo

- Ø 2,4 mm
- Ø 3,2 mm
- Ø 4,0 mm
- Ø 4,8 mm



| Nu.   | specificatie |   |
|-------|--------------|---|
| 24007 | 200 mm       | 1 |



**FESTA**

CLESTE NITURI

Cr-Mo

- Ø 2,4 mm
- Ø 3,2 mm
- Ø 4,0 mm
- Ø 4,8 mm



| Nu.   | specificatie |    |
|-------|--------------|----|
| 24010 | 250 mm       | 12 |



**FESTA**

CLESTE NITURI FRONTAL CU RECIPIENT COLECTARE

Cr-Mo

- Ø 2,4 mm
- Ø 3,2 mm
- Ø 4,0 mm
- Ø 4,8 mm
- Ø 6,4 mm



| Nu.   | specificatie |   |
|-------|--------------|---|
| 24017 | 280 mm       | 1 |



**FESTA**

CLESTE NITURI FRONTAL

Cr-Mo

- Ø 2,4 mm
- Ø 3,2 mm
- Ø 4,0 mm
- Ø 4,8 mm
- Ø 6,4 mm



| Nu.   | specificatie |   |
|-------|--------------|---|
| 24015 | 530 mm       | 1 |



**FESTA**

CLESTE NITURI

Cr-Mo

- Ø 2,4 mm
- Ø 3,2 mm
- Ø 4,0 mm
- Ø 4,8 mm



| Nu.   | specificatie |    |
|-------|--------------|----|
| 24030 | 255 mm       | 24 |



**FESTA**

CLESTE NITURI



| Nu.   | specificatie |   |
|-------|--------------|---|
| 24020 | 290 mm       | 8 |







CLEȘTE NITURI



| Nu.   | specificație |   |
|-------|--------------|---|
| 24001 | 260 mm       | 6 |

SET CLEȘTE NITURI

Cr-Mo

- Ø 2,4 x 6 mm
- Ø 3,2 x 6 mm
- Ø 4,0 x 6 mm
- Ø 4,8 x 6 mm



| Nu.   | specificație |   |
|-------|--------------|---|
| 24005 | 260 mm       | 5 |



CLEȘTE NITURI



| Nu.   | specificație |    |
|-------|--------------|----|
| 24000 | 240 mm       | 24 |

FESTA

ACCESORII DE NITUIRE PENTRU BURGHII

- Ø 2,4 mm
- Ø 3,2 mm
- Ø 4,0 mm
- Ø 4,8 mm



Cr-Mo

| Nu.   | specificație |   |
|-------|--------------|---|
| 24008 |              | 1 |



NITURI ALUMINIU

ALU

50x

| Nu.   | specificație |    |
|-------|--------------|----|
| 23970 | 3,2 x 6 mm   | 25 |
| 23971 | 3,2 x 8 mm   | 25 |
| 23972 | 3,2 x 10 mm  | 25 |
| 23973 | 3,2 x 12 mm  | 25 |
| 23974 | 3,2 x 14 mm  | 25 |
| 23975 | 4,0 x 6 mm   | 25 |
| 23976 | 4,0 x 8 mm   | 25 |
| 23977 | 4,0 x 10 mm  | 25 |
| 23978 | 4,0 x 12 mm  | 25 |
| 23979 | 4,0 x 14 mm  | 25 |
| 23985 | 4,8 x 6 mm   | 25 |
| 23986 | 4,8 x 8 mm   | 25 |
| 23987 | 4,8 x 10 mm  | 25 |
| 23988 | 4,8 x 12 mm  | 25 |
| 23989 | 4,8 x 14 mm  | 25 |



FESTA

CLEȘTE DE NITUIT PENTRU PIULIȚE DE NITUIRE

Cr-Mo

- M3
- M4
- M5
- M6
- M8
- M10



| Nu.   | specificație |   |
|-------|--------------|---|
| 24036 | 330 mm       | 1 |



FESTA

RIVETER HEAD

· suitable for 24035, 24036

Cr-Mo

| Nu.   | specificație |   |
|-------|--------------|---|
| 24038 | M3           | 1 |
| 24039 | M4           | 1 |
| 24040 | M5           | 1 |
| 24041 | M6           | 1 |
| 24042 | M8           | 1 |
| 24043 | M10          | 1 |



FESTA

CLEȘTE DE NITUIT PENTRU PIULIȚE DE NITUIRE

Cr-Mo

- M3
- M4
- M5
- M6



| Nu.   | specificație |   |
|-------|--------------|---|
| 24035 | 200 mm       | 1 |



PIULITE NITURI,

ALU





20x

| Nu.   | specificație |    |
|-------|--------------|----|
| 23950 | M3 x 9 mm    | 20 |
| 23951 | M4 x 11 mm   | 20 |
| 23952 | M5 x 12 mm   | 50 |
| 23953 | M6 x 14 mm   | 50 |
| 23954 | M8 x 16,5 mm | 25 |
| 23955 | M10 x 18 mm  | 20 |



**FESTA**

**CAPSATOR**





-  | 6 - 14 mm  
23960 - 23964  
23760 - 23764,  
23906 - 23914
-  | 10 - 14 mm  
23965
-  | 15 mm  
23966
-  | 15 mm  
23967



| Nu.   | specificație |  |
|-------|--------------|---|
| 23927 |              | 6   |

**FESTA**



**CAPSATOR**

-  | 6 - 14 mm  
23960 - 23964
-  | 12 mm  
23965
-  | 14 mm  
23966
-  | 14 mm  
23967





**FESTA**

**CAPSATOR**

-  | 6 - 14 mm  
23960 - 23964
-  | 14 mm  
23966
-  | 14 mm  
23967





| Nu.   | specificație |  | Nu.   | specificație |  |
|-------|--------------|---|-------|--------------|---|
| 23924 |              | 12  | 23923 |              | 12  |



**FESTA**

**CAPSATOR**

-  53 | 4 - 14 mm  
23904 - 23914,  
23760 - 23765

| Nu.   | specificație        |  |
|-------|---------------------|---|
| 23925 | 4 - 14 mm with lock | 20  |

**CAPSATOR**

-  53 | 4 - 14 mm  
23760 - 23765,  
23904 - 23914

| Nu.   | specificație |  |
|-------|--------------|--|
| 23800 |              | 20   |

**CAPSATOR**



-  0,7 mm  
a=9-11 mm, b=5,5mm, c=6,4mm

| Nu.   | specificație |  |
|-------|--------------|---|
| 23920 |              | 4   |



**FESTA**

**CIOCAN CAPSE PROFI**

-  | 6 - 10 mm  
23960 - 23962

| Nu.   | specificație |  |
|-------|--------------|---|
| 23922 |              | 10  |



**CIOCAN CAPSE**

-  | 6 - 10 mm  
23960 - 23962

| Nu.   | specificație |  |
|-------|--------------|--|
| 23928 |              | 6  |



**FESTA**

**DISPOZITIV ÎNDEPĂRTARE CAPSE**

| Nu.   | specificație |  |
|-------|--------------|---|
| 23945 |              | 25  |

**FESTA**

**CAPSE**



| Nu.   | specificatie      |    |
|-------|-------------------|----|
| 23960 | b=6 mm, 1000 buc  | 50 |
| 23961 | b=8 mm, 1000 buc  | 50 |
| 23962 | b=10 mm, 1000 buc | 50 |
| 23963 | b=12 mm, 1000 buc | 50 |
| 23964 | b=14 mm, 1000 buc | 50 |

**FESTA**

**CAPSE**

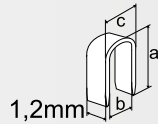

| Nu.   | specificatie                         |    |
|-------|--------------------------------------|----|
| 23965 | a=12 mm, b=6,5 mm, c=7,5 mm, 1000 TW | 50 |

**CAPSE (TYPE 53)**



| Nu.   | specificatie     |     |
|-------|------------------|-----|
| 23904 | b=4 mm 1000 buc  | 200 |
| 23906 | b=6 mm 1000 buc  | 200 |
| 23908 | b=8 mm 1000 buc  | 200 |
| 23910 | b=10 mm 1000 buc | 200 |
| 23912 | b=12 mm 1000 buc | 200 |
| 23914 | b=14 mm 1000 buc | 200 |

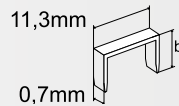

**FESTA**

**CAPSE**



| Nu.   | specificatie    |     |
|-------|-----------------|-----|
| 23966 | 14 mm   1000 TW | 100 |



**FESTA**

**CAPSE**



| Nu.   | specificatie    |     |
|-------|-----------------|-----|
| 23967 | 14 mm   1000 TW | 100 |



**CAPSE (TYPE 53)**



| Nu.   | specificatie     |    |
|-------|------------------|----|
| 23760 | b=4 mm 2000 buc  | 10 |
| 23761 | b=6 mm 2000 buc  | 10 |
| 23762 | b=8 mm 2000 buc  | 10 |
| 23763 | b=10 mm 2000 buc | 10 |
| 23764 | b=12 mm 2000 buc | 10 |

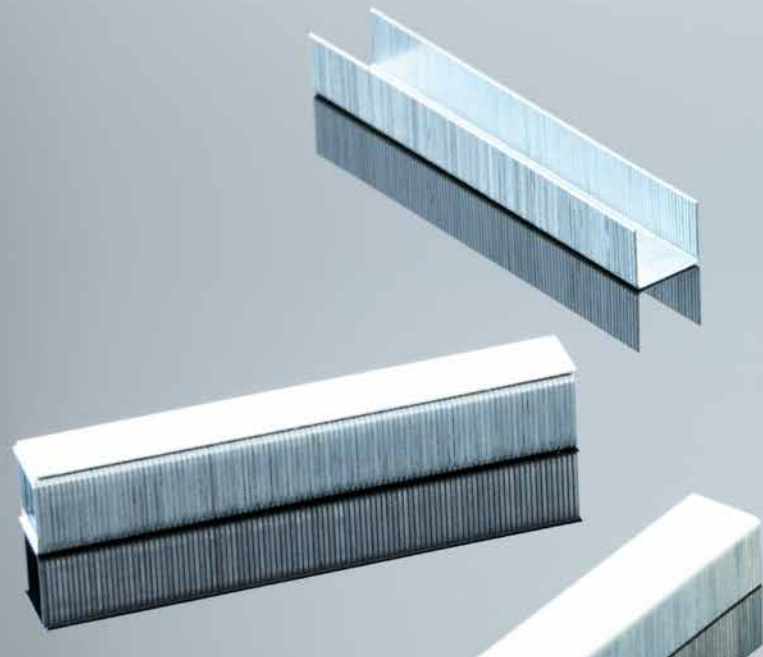
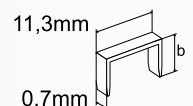

# FESTA



**FESTA**

**PERIE SARMA  
PLASTIC  
5 RANDURI**



| Nu.   | specificație | randuri   |    |
|-------|--------------|-----------|----|
| 22080 | 270 mm       | 5 randuri | 12 |

**FESTA**

**PERIE SARMA  
PLASTIC 5 RANDURI**



| Nu.   | specificație | randuri   |    |
|-------|--------------|-----------|----|
| 22082 | 270 mm       | 5 randuri | 12 |

**FESTA**

**SET DE PERII  
SARMA  
PLASTIC**



Nylon, oțel, alamă

**3x**

| Nu.   | specificație |    |
|-------|--------------|----|
| 22086 | 180 mm       | 12 |

**SET DE PERII  
SARMA  
PLASTIC**



**3x**

| Nu.   | randuri   |    |
|-------|-----------|----|
| 22081 | 3 randuri | 12 |



**PENSULA DE SĂRMĂ**

| Nu.   | specificație | sărmă |   |
|-------|--------------|-------|---|
| 22158 | 200 mm       | oțel  | 1 |
| 22159 | 200 mm       | alamă | 1 |



**PERIE SARMA MANER PLASTIC OTEL, METAL**

| Nu.   | specificație | sărmă           |    |
|-------|--------------|-----------------|----|
| 22035 | 270 mm       | oțel            | 24 |
| 22036 | 270 mm       | oțel inoxidabil | 24 |



**PERIE SARMA**

| Nu.   | specificație | randuri   |    |
|-------|--------------|-----------|----|
| 22033 | 300 mm       | 4 randuri | 12 |
| 22034 | 300 mm       | 5 randuri | 12 |

**PERIE MICA DE SARMA, LEMN  
cu acoperire de aramă**

| Nu.   | randuri   |    |
|-------|-----------|----|
| 22078 | 3 randuri | 20 |

**PERIE SARMA 4 RANDURI  
cu acoperire de aramă**

| Nu.   | specificație | randuri   |   |
|-------|--------------|-----------|---|
| 22079 | 300 mm       | 4 randuri | 6 |

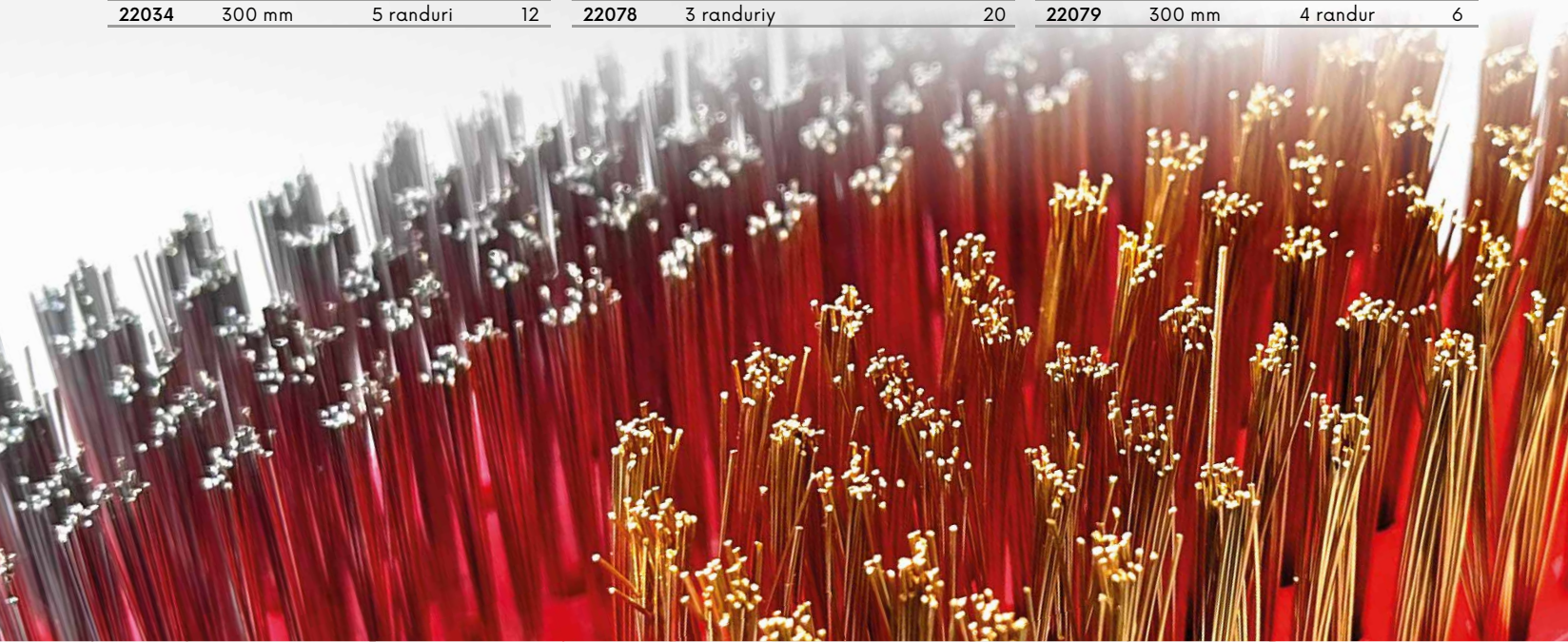

# FESTA



**FESTA**  
PILA DREAPTA



| Nu.   | specificatie | asperity |    |
|-------|--------------|----------|----|
| 22206 | 150 mm       | 2        | 10 |
| 22180 | 250 mm       | 2        | 10 |



**FESTA**  
PILA SEMIROTUNDA



| Nu.   | specificatie | asperity |    |
|-------|--------------|----------|----|
| 22207 | 150 mm       | 2        | 10 |
| 22182 | 250 mm       | 2        | 10 |



**FESTA**  
PILA PATRATA



| Nu.   | specificatie | asperity |    |
|-------|--------------|----------|----|
| 22184 | 250 mm       | 2        | 10 |



**FESTA**  
PILA TRIUNGHIULARA



| Nu.   | specificatie | asperity |    |
|-------|--------------|----------|----|
| 22183 | 250 mm       | 2        | 10 |



**FESTA**  
PILA ROTUNDA



| Nu.   | specificatie | asperity |    |
|-------|--------------|----------|----|
| 22181 | 250 mm       | 2        | 10 |



**FESTA**  
PILA TRIUNGHIULARA



| Nu.   | specificatie | asperity |    |
|-------|--------------|----------|----|
| 22178 | 150 mm       | 1        | 10 |

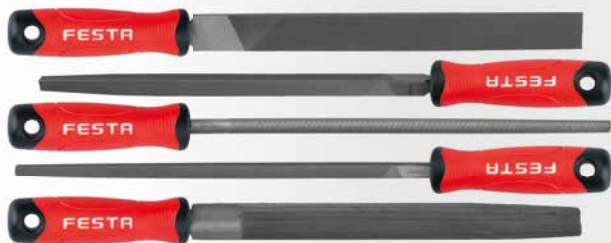

**FESTA**  
PILE SET



| Nu.   | specificatie | asperity |    |
|-------|--------------|----------|----|
| 22209 | 150 mm       | 2        | 10 |
| 22186 | 250 mm       | 2        | 5  |



**FESTA**  
PILE SET



| Nu.   | specificatie | asperity |    |
|-------|--------------|----------|----|
| 22208 | 150 mm       | 2        | 10 |
| 22185 | 250 mm       | 2        | 5  |



**FESTA**

**PILA PENTRU LANT DE FERASTRUU**



| Nu.   | specificatie |        |    | Nu.   | specificatie |        |    |
|-------|--------------|--------|----|-------|--------------|--------|----|
| 22170 | 200 mm       | 3,5 mm | 10 | 22173 | 200 mm       | 5 mm   | 10 |
| 22171 | 200 mm       | 4 mm   | 10 | 22174 | 200 mm       | 5,5 mm | 10 |
| 22172 | 200 mm       | 4,5 mm | 10 |       |              |        |    |



Ø 4 mm

**FESTA**

**ADAPTOR PENTRU ASCUTIT CU PILA**



| Nu.   | specificatie |   |
|-------|--------------|---|
| 22190 | 300 mm       | 5 |



**FESTA**

**SET PILE FINE**



| 10x | Nu.   | specificatie |    |
|-----|-------|--------------|----|
|     | 22188 |              | 20 |



**FESTA**

**SET PILE DIAMANTATE**



| 10x | Nu.   | specificatie |    |
|-----|-------|--------------|----|
|     | 22189 |              | 25 |



**FESTA**

**RASPILE**



| Nu.   | specificatie |    |
|-------|--------------|----|
| 22202 | 150 mm       | 10 |
| 22197 | 300 mm       | 10 |



**FESTA**

**RAZUITOARE GIPS-CARTON**



| 3x | Nu.   | specificatie |   |
|----|-------|--------------|---|
|    | 22196 | 250 mm       | 5 |



**FESTA**

**RASPILE**



| Nu.   | specificatie |   |
|-------|--------------|---|
| 22203 | 150 mm       | 6 |
| 22199 | 300 mm       | 6 |



**FESTA**

**RASPILE**



| Nu.   | specificatie |    |
|-------|--------------|----|
| 22204 | 150 mm       | 10 |
| 22205 | 250 mm       | 10 |
| 22198 | 300 mm       | 10 |



**FESTA**

FERASTRAU PENTRU METALE



| Nu.   | specificație |   |
|-------|--------------|---|
| 24104 | 300 mm       | 6 |

**FESTA**

FERASTRAU PENTRU METALE

datorie grea



| Nu.   | specificație |   |
|-------|--------------|---|
| 24102 | 300 mm       | 6 |

**FESTA**

FERASTRAU PENTRU METALE

FERASTRAU PENTRU METALE

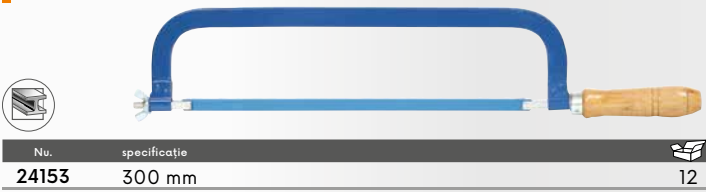

| Nu.   | specificație |    |
|-------|--------------|----|
| 24153 | 300 mm       | 12 |



| Nu.   | specificație |    |
|-------|--------------|----|
| 24100 | 300 mm       | 12 |

FERASTRAU PENTRU METALE

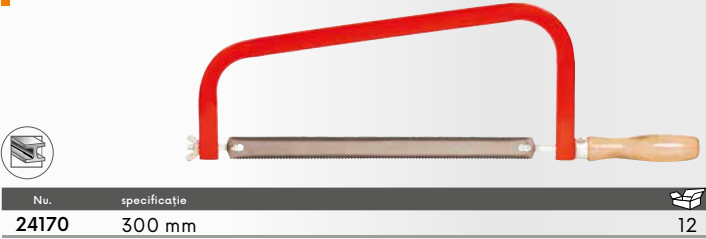

| Nu.   | specificație |    |
|-------|--------------|----|
| 24170 | 300 mm       | 12 |

**FESTA**

FERASTRAU PENTRU METALE



| Nu.   | specificație                   |    |
|-------|--------------------------------|----|
| 24126 | 300 x 25 x 0,65 mm TPI 24   14 | 10 |

**FESTA**

FERASTRAU PENTRU METALE

panza 24108



| Nu.   | specificație |   |
|-------|--------------|---|
| 24125 | 150 mm       | 6 |

**FESTA**

FERASTRAU PENTRU METALE

panza 24109



| Nu.   | specificație |    |
|-------|--------------|----|
| 24124 | 260 mm       | 12 |

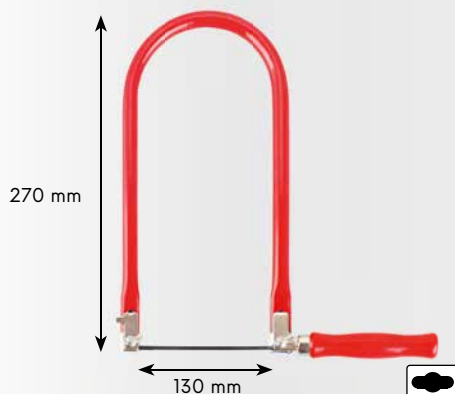

FERASTRAU

| Nu.   | specificație |    |
|-------|--------------|----|
| 24121 |              | 12 |
| 24110 | panzak       | 30 |

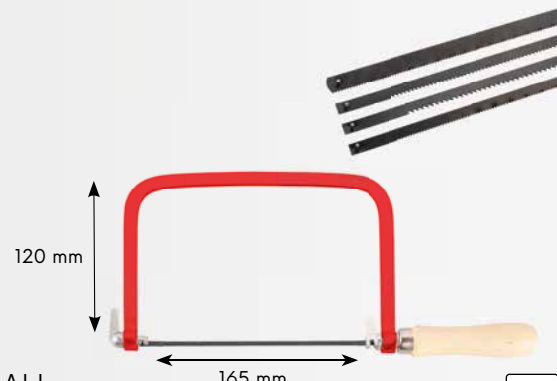

FERASTRAU

5x panza

| Nu.   | specificație |    |
|-------|--------------|----|
| 24122 |              | 20 |
| 24111 | panzak       | 30 |



**FESTA**

**FERASTRAU**

**TEFLON** · 3 randuri de dinti tratati termic

| Nu.   | specificatie |    |
|-------|--------------|----|
| 24143 | 300 mm       | 12 |
| 24144 | 400 mm       | 12 |
| 24145 | 500 mm       | 12 |



**FESTA**

**FERASTRAU DE SLUIT**

**TEFLON** · 3 randuri de dinti tratati termic

| Nu.   | specificatie |   |
|-------|--------------|---|
| 24147 | 300 mm       | 6 |



**FESTA**

**FERASTRAU PENTRU LEMN SI PAL**

· 3 randuri de dinti tratati termic

| Nu.   | specificatie |    |
|-------|--------------|----|
| 24149 | 300 mm       | 12 |



**FESTA**

**FERĂSTRĂU JAPONEZ**

**SKS** · 3 randuri de dinti tratati termic

| Nu.   | specificatie     |    |
|-------|------------------|----|
| 24134 | 250 mm    0,5 mm | 10 |



**FESTA**

**FERĂSTRĂU JAPONEZ**

**SKS** · 3 randuri de dinti tratati termic

| Nu.   | specificatie     |    |
|-------|------------------|----|
| 24115 | 260 mm    0,6 mm | 10 |



**FESTA**

**FERĂSTRĂU JAPONEZ**

**SKS** · 3 randuri de dinti tratati termic

| Nu.   | specificatie     |    |
|-------|------------------|----|
| 24114 | 260 mm    0,6 mm | 10 |

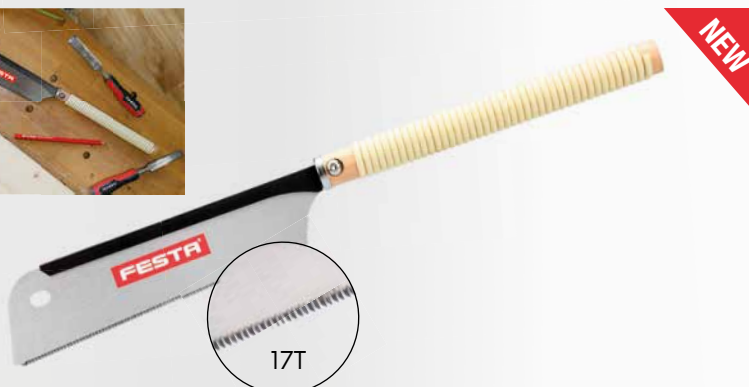

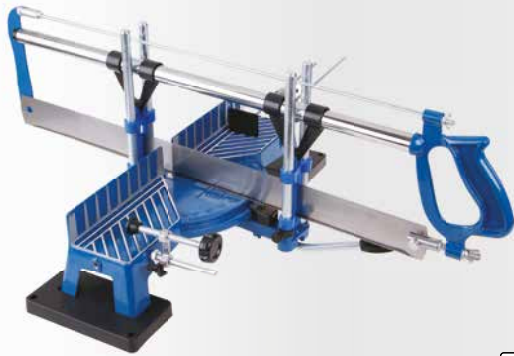

FERASTRAU IN UNGHI



| Nu.   | specificatie   |   |
|-------|----------------|---|
| 24130 | 600 mm         | 1 |
| 24131 | 600 mm, panzak | 1 |



FERASTRAU DE SLITUIT CU CUTIE



| Nu.   | specificatie |    |
|-------|--------------|----|
| 24148 | 300 mm       | 25 |

MITER BOX



| Nu.   | specificatie |    |
|-------|--------------|----|
| 24171 | 80 x 300 mm  | 10 |

MITER BOX



| Nu.   | specificatie |    |
|-------|--------------|----|
| 24133 | 300 x 140 mm | 18 |

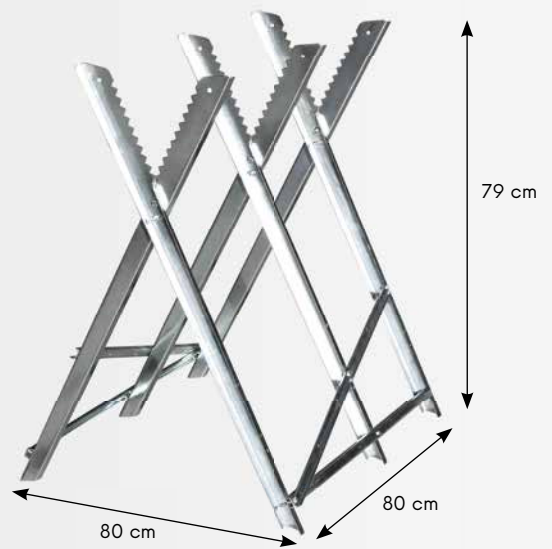

SUPPORT DE TĂIERE A LEMNULUI



| Nu.   | specificatie |   |
|-------|--------------|---|
| 37570 | max. 150 kg  | 3 |

**FESTA**

FERASTRAU PENTRU CRENGI

· tratati termi



| Nu.   | specificatie |    | Nu.   | specificatie |    |
|-------|--------------|----|-------|--------------|----|
| 24141 | 450 mm       | 12 | 24136 | 760 mm       | 12 |
| 24140 | 533 mm       | 12 | 24142 | 800 mm       | 12 |
| 24135 | 610 mm       | 12 | 24137 | 914 mm       | 12 |

**FESTA**

FERASTRAU ARC MOBIL

· tratati termi



| Nu.   | specificatie |    |
|-------|--------------|----|
| 24173 | 350 mm       | 24 |

FERASTRAU ARC PENTRU CRENGI



| Nu.   | specificatie |    |
|-------|--------------|----|
| 24151 | 300 mm       | 10 |

FERASTRAU PENTRU CRENGI



| Nu.   | specificatie |   |
|-------|--------------|---|
| 24150 | 300 mm       | 5 |

FERASTRAU UNIVERSAL

| Nu.   | specificație      |   |
|-------|-------------------|---|
| 24128 | 450 mm lame 24192 | 6 |



**FESTA**

FERASTRAU PLIANT



3 randuri de dinti tratati termic



| Nu.   | specificație  |    |
|-------|---------------|----|
| 45061 | 150 mm pliabi | 12 |



**FESTA**

FERASTRAU PLIANT



3 randuri de dinti tratati termic



| Nu.   | specificație |   |
|-------|--------------|---|
| 45060 | 180 mm       | 6 |



**FESTA**

FERASTRAU PLIANT



3 randuri de dinti tratati termic



| Nu.   | specificație      |    |
|-------|-------------------|----|
| 45062 | 260 mm cu carcasa | 24 |



FERASTRAU PENTRU CRENGI



3 randuri de dinti tratati termic



| Nu.   | specificație |    |
|-------|--------------|----|
| 24152 | 350 mm 6 tpi | 12 |

**FESTA**

FERASTRAU TELESCOPIC



3 randuri de dinti tratati termic



| Nu.   | specificație |   |
|-------|--------------|---|
| 45033 | 230 - 490 mm | 1 |

FERASTRAU TELESCOPIC



| Nu.   | specificație                          |   |
|-------|---------------------------------------|---|
| 45030 | ferastrau 30 cm pol telescopic 260 cm | 6 |
| 45031 | ferastrau 30 cm                       | 6 |

FERASTRAU TELESCOPIC



| Nu.   | specificație          |   |
|-------|-----------------------|---|
| 45032 | metal, fara ferastrau | 6 |

**FESTA**

## FERASTRAU PENTRU POLISTIREN

| Nu.   | specificație |  |
|-------|--------------|---|
| 24174 | 380 mm       | 1   |

**FESTA**

## FERASTRAU PENTRU GIPS-CARTON



· 3 randuri de dinti tratati termic

| Nu.   | specificație |  |
|-------|--------------|---|
| 24159 | 150 mm       | 12  |

**FESTA**

## FERASTRAU PENTRU POROTERM



| Nu.   | specificație |  |
|-------|--------------|---|
| 24181 | 550 mm       | 1   |



## FREZE TAIERE GIPSCARTON

| Nu.   | specificație |  |
|-------|--------------|---|
| 24190 | 270 mm       | 10  |

**FESTA**

## FERASTRAU PENTRU BCA



| Nu.   | specificație              |  |
|-------|---------------------------|---|
| 24158 | 22   22 SK dinti - 450 mm | 5   |

**FESTA**

## FERASTRAU PENTRU BCA



| Nu.   | specificație              |  |
|-------|---------------------------|---|
| 24155 | 34   17 SK dinti - 600 mm | 2   |
| 24156 | 34   34 SK dinti - 600 mm | 2   |

**FESTA**

## FERASTRAU YTONG

· tratati termic



| Nu.   | specificație             |  |
|-------|--------------------------|---|
| 24175 | bez SK dinti - 600 mm EU | 2   |
| 24178 | bez SK dinti - 600 mm    | 6   |

**FESTA**

## FERASTRAU YTONG

| Nu.   | specificație              |  |
|-------|---------------------------|---|
| 24176 | 34   17 SK dinti - 750 mm | 6   |
| 24177 | 34   34 SK dinti - 750 mm | 6   |





**FESTA**

CIOCAN MANER LEMN

· mâner de frasin

**DIN 1041**

| Nu.   | specificație |   |
|-------|--------------|---|
| 19081 | 100 g        | 1 |
| 19082 | 200 g        | 1 |
| 19083 | 300 g        | 1 |
| 19084 | 400 g        | 1 |
| 19085 | 500 g        | 1 |
| 19086 | 600 g        | 1 |
| 19088 | 800 g        | 1 |
| 19090 | 1000 g       | 1 |
| 19092 | 1500 g       | 1 |
| 19095 | 2000 g       | 1 |



**FESTA**

CIOCAN MANER LEMN

· mâner de frasin

**DIN 1041**

| Nu.   | specificație |   |
|-------|--------------|---|
| 19096 | 3000 g       | 1 |
| 19097 | 4000 g       | 1 |
| 19098 | 5000 g       | 1 |
| 19106 | 6000 g       | 1 |
| 19108 | 8000 g       | 1 |
| 19109 | 10000 g      | 1 |



**FESTA**

CIOCAN MANER LEMN

· mâner de frasin

**DIN 6475**

| Nu.   | specificație |   |
|-------|--------------|---|
| 19041 | 1000 g       | 1 |
| 19042 | 1250 g       | 1 |
| 19043 | 1500 g       | 1 |
| 19044 | 2000 g       | 1 |



**FESTA**

CIOCAN MANER LEMN

· mâner de frasin

**DIN 6475**

| Nu.   | specificație |   |
|-------|--------------|---|
| 19045 | 3000 g       | 1 |
| 19046 | 4000 g       | 1 |
| 19074 | 5000 g       | 1 |
| 19075 | 6000 g       | 1 |
| 19076 | 8000 g       | 1 |
| 19077 | 10000 g      | 1 |



**FESTA**

CIOCAN MANER FIBRA

· fiberglass

| Ç.p.  | specifikace |    |
|-------|-------------|----|
| 19021 | 100 g       | 12 |
| 19022 | 200 g       | 12 |
| 19023 | 300 g       | 12 |
| 19024 | 400 g       | 12 |
| 19025 | 500 g       | 12 |
| 19026 | 600 g       | 6  |
| 19028 | 800 g       | 6  |
| 19030 | 1000 g      | 6  |
| 19031 | 1500 g      | 6  |
| 19032 | 2000 g      | 1  |



**FESTA**

CIOCAN MANER FIBRA

· fiberglass

**DIN 6475**

| Ç.p.  | specifikace |   |
|-------|-------------|---|
| 19066 | 1000 g      | 4 |
| 19067 | 1250 g      | 4 |
| 19068 | 1500 g      | 4 |
| 19069 | 2000 g      | 2 |

**FESTA**

CIOCAN MANER FIBRA

· fiberglass



| Ç.p.  | specifikace |   |
|-------|-------------|---|
| 19034 | 3000 g      | 4 |
| 19036 | 4000 g      | 4 |



**FESTA**

CIOCAN MANER FIBRA

· fiberglass

**DIN 6475**

| Ç.p.  | specifikace |   |
|-------|-------------|---|
| 19070 | 3000 g      | 4 |
| 19071 | 4000 g      | 4 |
| 19058 | 5000 g      | 4 |
| 19059 | 6000 g      | 2 |

**FESTA****CIOCAN  
DULGHER  
MANER FIBRA**

· fiberglass



| Ĉ.p.  | specifikace |   |
|-------|-------------|---|
| 19061 | 600 g       | 6 |

**FESTA****CIOCAN CU VARF  
DESPICAT,  
MANER FIBRA**

· fiberglass

| Ĉ.p.  | specifikace |   |
|-------|-------------|---|
| 19064 | 450 g       | 6 |

**FESTA****CIOCAN  
CU VARF  
SPINTECAT**

| Ĉ.p.  | specifikace |   |
|-------|-------------|---|
| 19062 | 600 g       | 6 |

**FESTA****CIOCAN CU VARF  
SPINTECAT  
MONOLIT**

| Ĉ.p.  | specifikace |   |
|-------|-------------|---|
| 19063 | 450 g       | 6 |

**CIOCAN  
DULGHER**

| Ĉ.p.  | specifikace |   |
|-------|-------------|---|
| 19100 | 600 g       | 6 |

**FESTA****CIOCAN  
ZIDAR  
MONOLIT**

| Ĉ.p.  | specifikace |   |
|-------|-------------|---|
| 19150 | 600 g       | 6 |

**FESTA****CIOCAN  
DULGHER**

| Ĉ.p.  | specifikace |   |
|-------|-------------|---|
| 19060 | 600 g       | 6 |

**FESTA****CIOCAN CU  
VARF SPINTECAT**

| Ĉ.p.  | specifikace |   |
|-------|-------------|---|
| 19065 | 450 g       | 6 |

**FESTA****CIOCAN ZIDAR  
MANER FIBRA**

· fiberglass

| Ĉ.p.  | specifikace |   |
|-------|-------------|---|
| 19151 | 600 g       | 6 |

**FESTA****CIOCAN ZIDAR**

· mâner de frasin

| Ĉ.p.  | specifikace |   |
|-------|-------------|---|
| 19149 | 44 mm       | 1 |

**FESTA****CIOCAN ZIDAR**

· mâner de frasin

| Ĉ.p.  | specifikace |   |
|-------|-------------|---|
| 19124 | 24 mm       | 1 |
| 19136 | 36 mm       | 1 |
| 19148 | 48 mm       | 1 |

**FESTA****CIOCAN - TOPOR**

| Ĉ.p.  | specifikace |   |
|-------|-------------|---|
| 19303 | 600 g       | 6 |



**FESTA**

**CIOCAN DE LEMN**

| Č.p.  | specifikace |   |
|-------|-------------|---|
| 19051 | 1000 g      | 6 |
| 19052 | 1500 g      | 6 |



**CIOCAN MANER LEMN**

· circulara

**DIN 6475**

| Č.p.  | specifikace |   |
|-------|-------------|---|
| 19053 | 1000 g      | 6 |
| 19050 | 1250 g      | 6 |
| 19054 | 1500 g      | 6 |
| 19055 | 2000 g      | 6 |



**CIOCAN MANER LEMN**

· circulara

**DIN 1041**

| Č.p.  | specifikace |    |
|-------|-------------|----|
| 19001 | 100 g       | 12 |
| 19002 | 200 g       | 12 |
| 19003 | 300 g       | 6  |
| 19004 | 400 g       | 6  |
| 19005 | 500 g       | 6  |
| 19006 | 600 g       | 6  |
| 19008 | 800 g       | 6  |
| 19010 | 1000 g      | 6  |
| 19015 | 1500 g      | 6  |
| 19020 | 2000 g      | 6  |



**CIOCAN MANER LEMN**

· circulara

**DIN 6475**

| Č.p.  | specifikace |   |
|-------|-------------|---|
| 19056 | 3000 g      | 6 |
| 19057 | 4000 g      | 6 |

**CIOCAN SUDURA**



| Č.p.  | specifikace |   |
|-------|-------------|---|
| 19115 | 320 g       | 1 |



**FESTA**

**COADA LEMN CIOCAN**

| Nu.   | specificație |   |
|-------|--------------|---|
| 61240 | măner        | 1 |



**COADA LEMN CIOCAN**



| Nu.   | specificație | pentru ciocan |    |
|-------|--------------|---------------|----|
| 61320 | 26 cm        | 19081         | 10 |
| 61321 | 28 cm        | 19082         | 10 |
| 61322 | 30 cm        | 19083         | 10 |
| 61323 | 31 cm        | 19084         | 10 |
| 61324 | 32 cm        | 19085         | 10 |



**COADA LEMN CIOCAN**

| Nu.   | specificație | pentru ciocan |    |
|-------|--------------|---------------|----|
| 61330 | 80 cm        | 19074, 19075  | 10 |
| 61331 | 90 cm        | 19076, 19077  | 10 |



**PANA CONICA**

| Nu.   | specificație |    |
|-------|--------------|----|
| 19430 | 6 mm         | 10 |
| 19431 | 8 mm         | 10 |
| 19432 | 10 mm        | 10 |
| 19433 | 12 mm        | 10 |
| 19434 | 14 mm        | 10 |
| 19435 | 16 mm        | 10 |



**PANA OTEL**



| Nu.   | specificație |    |
|-------|--------------|----|
| 19440 | narrow       | 10 |
| 19441 | middle       | 10 |
| 19442 | wide         | 10 |
| 19443 | wide S       | 10 |



**FESTA**

**PANA OTEL**



**3x**

| Nu.   | specificație   |   |
|-------|----------------|---|
| 19398 | 20 x 25 x 5 mm | 1 |
| 19399 | 30 x 40 x 5 mm | 1 |





# FESTA



**FESTA**

## CIOCAN DIN LEMN

· bükkfa nyél



| Nu.   | specificatie        |   |
|-------|---------------------|---|
| 19202 | Ø 60 x 120 mm 260 g | 1 |



**FESTA**

## CIOCAN CAUCIUC

· kőrisfa nyél



| Nu.   | specificatie    |   |
|-------|-----------------|---|
| 19245 | Ø 55 mm 400 g   | 1 |
| 19246 | Ø 60 mm 800 g   | 1 |
| 19247 | Ø 70 mm 1000 g  | 1 |
| 19248 | Ø 95 mm 2000 g  | 1 |
| 19249 | Ø 115 mm 3000 g | 1 |



**FESTA**

CIOCAN CAUCIUC NEGRU

· fiberglass



| Nu.   | specificatie |   |
|-------|--------------|---|
| 19270 | Ø 55 mm      | 6 |
| 19271 | Ø 65 mm      | 6 |
| 19272 | Ø 90 mm      | 6 |



**FESTA**

CIOCAN CAUCIUC NEGRU



| Nu.   | specificatie |   |
|-------|--------------|---|
| 19255 | Ø 55 mm      | 6 |
| 19265 | Ø 65 mm      | 6 |
| 19290 | Ø 90 mm      | 6 |



**FESTA**

CIOCAN CAUCIUC ALB

· fiberglass

| Nu.   | specificatie |   |
|-------|--------------|---|
| 19281 | 680g         | 6 |



**NEW**

**FESTA**

CIOCAN CAUCIUC ALB



| Nu.   | specificatie |   |
|-------|--------------|---|
| 19293 | Ø 55 mm      | 6 |
| 19294 | Ø 65 mm      | 6 |
| 19295 | Ø 90 mm      | 6 |



**FESTA**

CIOCAN  
CAP BRONZ

· fiberglass

| Nu.   | specificatie  |   |
|-------|---------------|---|
| 19211 | Ø 30 mm 500 g | 1 |



**FESTA**

CIOCAN NYLON

· fiberglass



| Nu.   | specificatie |   |
|-------|--------------|---|
| 19209 | Ø 34 mm      | 6 |



CIOCAN  
CAUCIUC NEGRU



| Nu.   | specificatie   |    |
|-------|----------------|----|
| 19251 | Ø 55 mm 400 g  | 12 |
| 19252 | Ø 65 mm 700 g  | 6  |
| 19253 | Ø 90 mm 1300 g | 4  |



CIOCAN CAUCIUC  
ALB NEGRU



| Nu.   | specificatie |   |
|-------|--------------|---|
| 19254 | Ø 65 mm      | 6 |



CIOCAN  
SILICON

| Nu.   | specificatie |    |
|-------|--------------|----|
| 19297 | Ø 30 mm      | 12 |



**FESTA**

CIOCAN CU CAPETE INTERSCHIMBABILE

- PP - 97 Shore A ·
- TPU - 95 Shore A ·
- TPE - 90 Shore A ·
- TPE - 90 Shore A ·
- TPU - 92 Shore A ·
- TPU - 92 Shore A ·
- TPU - 88 Shore A ·
- TPE - 90 Shore A ·

| Nu.   | specificatie |   |
|-------|--------------|---|
| 19208 | Ø 38 mm      | 1 |

KIT REPARATIE



7x



| Nu.   | specificatie |
|-------|--------------|
| 19110 |              |

5



FESTA

RANGA



| Nu.   | specificatie |   |
|-------|--------------|---|
| 19420 | 300 mm       | 1 |



FESTA

RANGA

| Nu.   | specificatie |   |
|-------|--------------|---|
| 19424 | 400 mm       | 6 |
| 19425 | 600 mm       | 6 |
| 19426 | 800 mm       | 6 |
| 19427 | 1000 mm      | 6 |



RANGA

| Nu.   | specificatie    |   |
|-------|-----------------|---|
| 19416 | 600 mm Ø 16 mm  | 4 |
| 19422 | 800 mm Ø 16 mm  | 4 |
| 19421 | 1000 mm Ø 18 mm | 4 |



RANGA

| Nu.   | specificatie    |   |
|-------|-----------------|---|
| 19423 | 380 x 35 x 6 mm | 1 |



FESTA

RANGA CU EXTRACTOR CUIE

| Nu.   | specificatie   |   |
|-------|----------------|---|
| 19415 | 300 mm Ø 15 mm | 6 |





**FESTA**

**DALTA LATA MANER PROTECTIE**

| CrV | Nu.   | specificație | lățime hrotu |   |
|-----|-------|--------------|--------------|---|
|     | 19406 | 300 mm       | 25 mm        | 5 |
|     | 19407 | 400 mm       | 30 mm        | 5 |



**FESTA**

**DALTA SPIT MANER PROTECTIE**

| CrV | Nu.   | specificație | lățime hrotu |   |
|-----|-------|--------------|--------------|---|
|     | 19408 | 250 mm       |              | 5 |
|     | 19409 | 350 mm       |              | 5 |



**FESTA**

**DALTA LATA MANER PROTECTIE**

| CrV | Nu.   | specificație | lățime hrotu |   |
|-----|-------|--------------|--------------|---|
|     | 19460 | 300 mm       | 25 mm        | 5 |
|     | 19470 | 400 mm       | 30 mm        | 5 |



**DALTA SPIT MANER PROTECTIE**

| Nu.   | specificație |   |
|-------|--------------|---|
| 19400 | 250 mm       | 5 |
| 19403 | 350 mm       | 6 |



**DALTA LATA MANER PROTECTIE**

| Nu.   | specificație | lățime hrotu |   |
|-------|--------------|--------------|---|
| 19401 | 250 mm       | 19 mm        | 6 |
| 19404 | 350 mm       | 22 mm        | 6 |



**DALTA LATA MANER PROTECTIE**

| Nu.   | specificație | lățime hrotu |   |
|-------|--------------|--------------|---|
| 19402 | 250 mm       | 50 mm        | 2 |
| 19405 | 350 mm       | 50 mm        | 6 |



**FESTA**

**SET DALTI SI POANSOANE**

**12x CrV**

- 2, 6, 8 mm
- 10, 12, 16 mm
- Ø 1,5-3-4-5-6-8 mm

| Nu.   | specificație |   |
|-------|--------------|---|
| 19487 |              | 4 |



**FESTA**

**SET DALTI SI POANSOANE**

**6x CrV**

- 2 x 140, 8 x 115 mm
- 12 x 152, 10 x 142 mm
- Ø 3 x 152, 6 x 152 mm

| Nu.   | specificație |    |
|-------|--------------|----|
| 19486 |              | 10 |



**FESTA**

**SET DALTI**

**3x CrV**

- 10, 12, 16 mm

| Nu.   | specificație |    |
|-------|--------------|----|
| 19485 |              | 10 |



**FESTA**

**DALTA SPIT**

**CrV**

| Nu.   | specificație |   |
|-------|--------------|---|
| 19429 | 200 mm       | 1 |



**FESTA**

**DALTA LATA**

**CrV**

| Nu.   | specificație | lățime hrotu |    |
|-------|--------------|--------------|----|
| 19410 | 200 mm       | 20 mm        | 10 |
| 19411 | 250 mm       | 25 mm        | 10 |
| 19412 | 300 mm       | 25 mm        | 10 |
| 19418 | 400 mm       | 25 mm        | 5  |
| 19419 | 500 mm       | 25 mm        | 5  |



**DALTA LATA**

**CrV**

| Nu.   | specificație | lățime hrotu |    |
|-------|--------------|--------------|----|
| 19436 | 200 mm       | 20 mm        | 15 |

**FESTA**

DORN,  
SET CRV

CrV 3x

| Nu.   | specificatie       |    |
|-------|--------------------|----|
| 19480 | Ø 0,8, 1,5, 2,5 mm | 10 |



**FESTA**

PUNCTATOR,  
SET CRV

CrV 3x

| Nu.   | specificatie       |    |
|-------|--------------------|----|
| 19481 | Ø 0,8, 1,5, 2,5 mm | 10 |



**FESTA**

DORN,  
SET CRV

CrV 6x

| Nu.   | specificatie          |   |
|-------|-----------------------|---|
| 19483 | Ø 3, 4, 5, 6, 7, 8 mm | 5 |



**FESTA**

PUNCTATOR

CrV

| Nu.   | specificatie |    |
|-------|--------------|----|
| 19477 | Ø 2,5 mm     | 20 |



**FESTA**

PUNCTATOR  
AUTOMAT

CrV

| Nu.   | specificatie |    |
|-------|--------------|----|
| 19478 | Ø 2,5 mm     | 12 |



**FESTA**

DORN

CrV

| Nu.   | specificatie  |   |
|-------|---------------|---|
| 19472 | Ø 4 mm 150 mm | 1 |
| 19473 | Ø 5 mm 150 mm | 1 |
| 19474 | Ø 6 mm 150 mm | 1 |



TAIETOR GEAM RS-G



| Nu.   | specificatie |    |
|-------|--------------|----|
| 20350 | 130 mm       | 12 |



SET PENTRU PREDUCIT

- 24690 - Ø 2,5 mm
- Ø 3 mm
- Ø 4 mm
- Ø 5 mm
- Ø 6 mm
- Ø 7 mm
- Ø 8 mm
- Ø 9 mm
- Ø 10 mm
- 24691 - Ø 2mm
- Ø 2,5 mm
- Ø 3,2 mm
- Ø 4 mm
- Ø 4,8 mm
- Ø 5 mm
- Ø 6,4 mm
- Ø 8 mm
- Ø 9,5 mm
- Ø 11,1 mm
- Ø 12,7 mm
- Ø 14 mm
- Ø 15,8 mm
- Ø 19 mm
- Ø 22 mm



| Nu.   | specificatie        |    |
|-------|---------------------|----|
| 24690 | 9 buc Ø 2,5 - 10 mm | 10 |
| 24691 | 15 buc Ø 2 - 22 mm  | 5  |

SET PENE ROTUNDE

| Nu.       | specificatie   |   |
|-----------|--|---|
| 13x 24695 | Ø 5, 6, 8, 10, 11, 13, 16, 19, 22, 25, 28, 32, 35 mm | 5 |



POANSON NUMERE

| Nu.   | specificatie |   |
|-------|--------------|---|
| 20972 | 6 mm         | 5 |
| 20973 | 8 mm         | 5 |

POANSON LITERE

| Nu.   | specificatie |   |
|-------|--------------|---|
| 20970 | 6 mm         | 5 |
| 20971 | 8 mm         | 5 |





**MENGHINA RAPIDA**

| Nu.   | specificatie |   |
|-------|--------------|---|
| 23625 | 150 mm       | 6 |
| 23626 | 300 mm       | 6 |
| 23628 | 450 mm       | 6 |
| 23630 | 600 mm       | 6 |
| 23632 | 760 mm       | 6 |



**NEW**



**CUPLAJ DE EXTENSIE PENTRU CLEME**

FESTA INDUSTRY 23625, 23626, 23628, 23630

**2x**



| Nu.   | specificatie |   |
|-------|--------------|---|
| 23635 |              | 6 |



**MENGHINA RAPIDA**



| Nu.   | specificatie |   |
|-------|--------------|---|
| 23570 | 100 x 80 mm  | 1 |
| 23571 | 160 x 80 mm  | 1 |
| 23572 | 200 x 80 mm  | 1 |
| 23573 | 250 x 80 mm  | 1 |
| 23574 | 300 x 80 mm  | 1 |

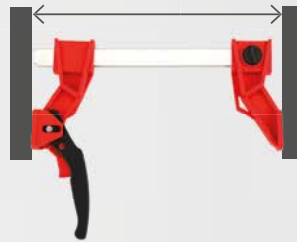

**MENGHINA MANUALA PROFIL**

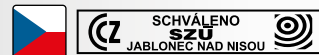

| Nu.   | specificatie  |   |
|-------|---------------|---|
| 23670 | 150 x 105 mm  | 1 |
| 23671 | 200 x 105 mm  | 1 |
| 23672 | 250 x 105 mm  | 1 |
| 23673 | 300 x 105 mm  | 1 |
| 23674 | 350 x 105 mm  | 1 |
| 23675 | 400 x 175 mm  | 1 |
| 23676 | 500 x 175 mm  | 1 |
| 23677 | 600 x 175 mm  | 1 |
| 23678 | 700 x 175 mm  | 1 |
| 23679 | 800 x 175 mm  | 1 |
| 23680 | 1000 x 175 mm | 1 |
| 23681 | 1250 x 175 mm | 1 |
| 23682 | 1500 x 175 mm | 1 |
| 23683 | 1750 x 175 mm | 1 |
| 23684 | 2000 x 175 mm | 1 |
| 23685 | 2200 x 175 mm | 1 |



**MENGHINA RAPIDA**

| Nu.   | specificatie |   |
|-------|--------------|---|
| 23585 | 150 mm       | 6 |
| 23587 | 300 mm       | 6 |
| 23589 | 450 mm       | 6 |
| 23591 | 600 mm       | 6 |



**FESTA**

**MENGHINA RAPIDA**

- kovácsolt
- picătură forjată

| Nu.   | specificatie  |  |
|-------|---------------|---|
| 23560 | 200 x 80 mm   | 1   |
| 23561 | 300 x 100 mm  | 1   |
| 23562 | 400 x 100 mm  | 1   |
| 23563 | 500 x 120 mm  | 1   |
| 23564 | 600 x 120 mm  | 1   |
| 23565 | 800 x 120 mm  | 1   |
| 23566 | 1000 x 120 mm | 1   |



**MENGHINA MANUALA**

**DIN 5117**

| Nu.   | specificatie |  |
|-------|--------------|---|
| 23506 | 300 x 120 mm | 10  |
| 23507 | 500 x 120 mm | 10  |
| 23508 | 800 x 120 mm | 6   |



**MENGHINA MANUALA**

| Nu.   | specificatie |  |
|-------|--------------|---|
| 23515 | 150 x 50 mm  | 50  |
| 23520 | 200 x 50 mm  | 50  |
| 23525 | 250 x 50 mm  | 50  |
| 23530 | 300 x 50 mm  | 50  |
| 23531 | 300 x 120 mm | 20  |
| 23551 | 500 x 120 mm | 10  |



**NEW**



**FESTA**

**CLEME MASA DE LUCRU**

| Nu.   | specificatie       |  |
|-------|--------------------|---|
| 23595 | 250/ Ø 20 mm 60 kg | 1   |



**NEW**



**FESTA**

**CLEME MASA DE LUCRU**

| Nu.   | specificatie       |  |
|-------|--------------------|---|
| 23598 | 120/ Ø 20 mm 70 kg | 1   |

**NEW**



**FESTA**

**CLEMĂ DE STRÂNGERE RAME**

| Nu.   | specificatie |  |
|-------|--------------|---|
| 23637 | 4m x 25mm    | 1   |

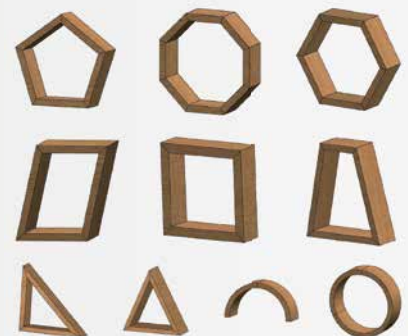

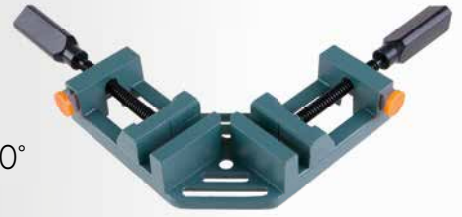

**FESTA**

90° MENGHINA



4x

| Nu.   | specificație              |   |
|-------|---------------------------|---|
| 23607 | forța de prindere - 250 N | 1 |

MENGHINA 90°

ALU

gama 0-65 mm



| Nu.   | specificație |    |
|-------|--------------|----|
| 23420 | 65 mm        | 20 |



CLEME LEMN

deschidere 80 mm

| Nu.   | specificație |   |
|-------|--------------|---|
| 23605 | 9'   230 mm  | 6 |



DISPOZITIV PRINDERE

| Nu.   | specificație          |    |
|-------|-----------------------|----|
| 23600 | 4', deschidere 40 mm  | 20 |
| 23601 | 6', deschidere 70 mm  | 12 |
| 23602 | 9', deschidere 100 mm | 20 |



SET DISPOZITIVE PRINDERE

| Nu.   | specificație        |    |
|-------|---------------------|----|
| 23620 | 25 mm, 50 mm, 75 mm | 10 |



**FESTA**



208

MASA LUCRU REGLABILA



212

MENGHINĂ



213

CRICURI HIDRAULICE



218

LĂMPI ȘI LUMINILĂMPĂK



220

CHINGI SI FRANGHII



224

BANDA



227

CÂRLIGELE DE PRINDERE  
LANȚURI

230

PRODUSE DE SIGURANȚĂ



234

TOATE CAZURILE



237

LACAT



239

CASUTE POSTALE,  
CUTI DE VALORI



ATELIER

208 - 243



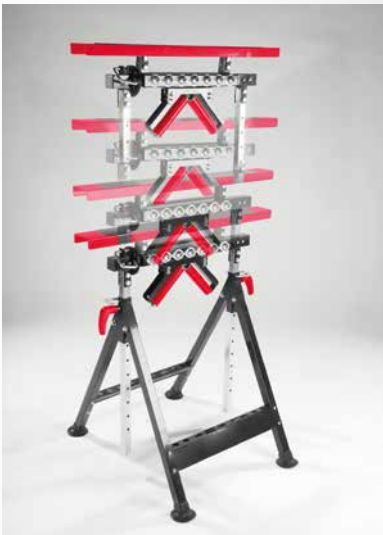

max 200 kg



max 45 kg



max 100 kg



max 100 kg



**FESTA**

**CAPRA AJUSTABILA**

· max. sarcină: 200 kg

Nu. specificație

36410



1

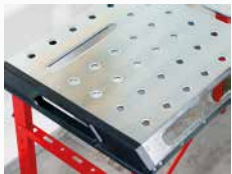

**FESTA**

**MASA DE SUDURA RABATABILA**

· max. sarcină: 450 kg

Nu. specificație

23652



1



**FESTA**

**CAPRA AJUSTABILA**

· max. sarcină: 590 kg

Nu. Specificație

23657



1



NEW



2x



4x



FESTA

### MASA PORTABILA DE LUCRU, COMPATIBIL CU 23664

- 1270 x 670 x 900 mm
- max. sarcină: 1100 kg



1

Nu. specificație  
23661

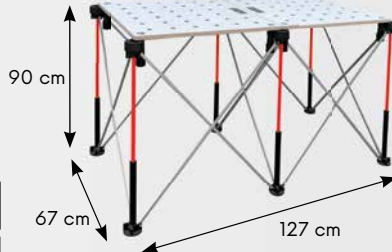

NEW



FESTA

### BLAT DE LUCRU, COMPATIBIL CU 23661

- 1200 x 600 x 18 mm



1

Nu. specificație  
23664



FESTA

### CAPRA AJUSTABILA

- max. sarcină: 230 kg



1

Nu. specificație  
23658

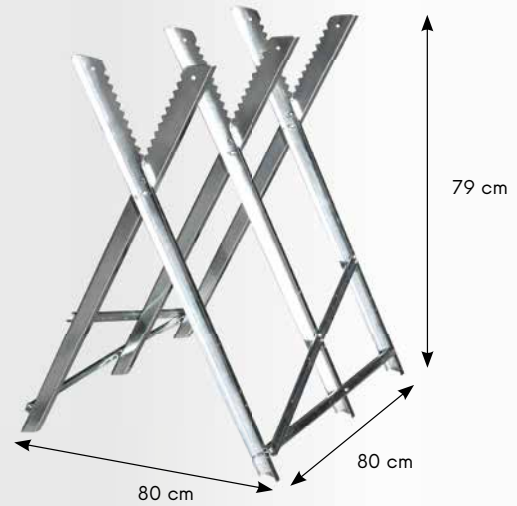

### CAPRĂ PE TĂIEREA LEMNULUI

- max. sarcină: 150 kg



1

Nu. specificație  
37570



### CAPRA AJUSTABILA

- max. sarcină: 125 kg



1

Nu. specificație  
36300



### CAPRA AJUSTABILA - PLASTIC

- max. sarcină 150 kg (300 kg în mână)

2x

Nu. specificație  
37560

1

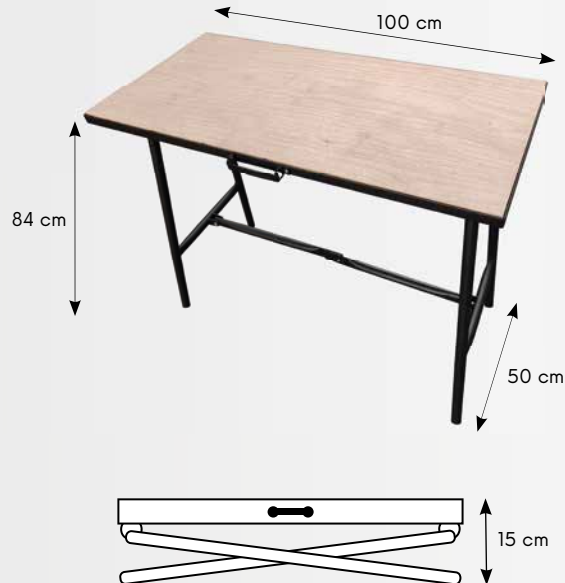
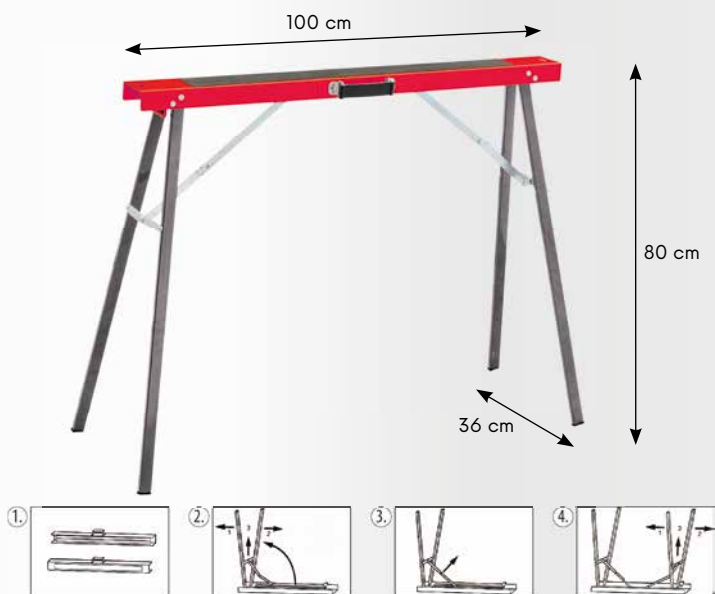

**CAPRA AJUSTABILA**

· max. sarcină 125 kg

| <b>2x</b> |              |   |  |
|-----------|--------------|---|--|
| Nu.       | specificatie |   |  |
| 37549     | pár          | 1 |  |

**MASA LUCRU REGLABILA**

· max. 100 kg

| Nu.   | Specificatie     |   |  |
|-------|------------------|---|--|
| 23655 | 100 x 50 x 84 cm | 1 |  |



**MASA LUCRU REGLABILA**

· ideal pentru beci

| Nu.   | specificatie |   |  |
|-------|--------------|---|--|
| 23660 |              | 1 |  |



**MASA LUCRU REGLABILA**

· max. sarcină: 100 kg

| Nu.   | specificatie |   |  |
|-------|--------------|---|--|
| 23650 |              | 1 |  |



**SCAUN PE ROLE**

· padded roller seat with plastic tool tray.

| Nu.   | Specificatie       |   |  |
|-------|--------------------|---|--|
| 26988 | 360 x 365 x 365 mm | 1 |  |

**FESTA**

**SUPPORT MAGNETIC PENTRU SCULE**



| Nu.   | specificatie |    |  |
|-------|--------------|----|--|
| 70098 |              | 12 |  |



**FESTOOL****DULAP PENTRU SCULE**

| Nu.   | Drawers slides | Sertare | Dimensiuni totale   |   |
|-------|----------------|---------|---------------------|---|
| 26986 | Neted          | 7       | 680 x 460 x 1020 mm | 1 |

**DULAP PENTRU SCULE**

Top chest can be put into roller cabinet.

| Nu.   | specificație | Dispozitiv sertare | Sertare | Dimensiuni interioare sertar WxDxH | Dimensiuni totale  | Total Greutate |   |
|-------|--------------|--------------------|---------|------------------------------------|--------------------|----------------|---|
| 26985 | top case     | Neted              | 3       | 151,5 x 225 x 40 mm                | 600 x 260 x 340 mm | 11,5 kg        | 1 |
|       |              |                    | 2       | 511 x 225 x 40 mm                  |                    |                |   |
|       | bottom case  | Neted              | 1       | 511 x 225 x 85 mm                  | 616 x 330 x 742 mm | 16,4 kg kg     |   |
|       |              |                    | 2       | 511 x 308 x 85 mm                  |                    |                |   |

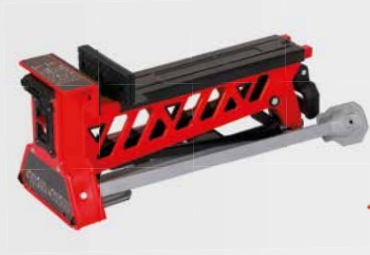
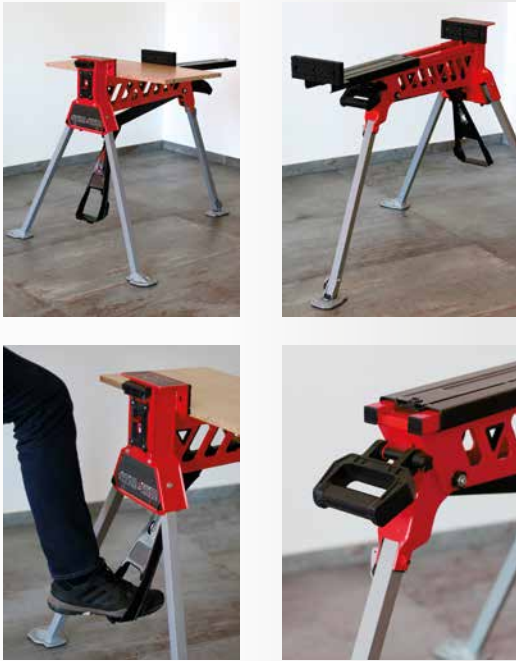

**FESTA**

**MENGHINĂ PORTABILĂ**

- Gama de prindere: 0 - 95 cm
- max. sarcină: 250 kg

| Nu.   | Specificație |
|-------|--------------|
| 37553 |              |



**FESTA**

**MENGHINA**

- maxilarul întărit

| Nu.   | specificație |   |  |
|-------|--------------|---|--|
| 23410 | 100 mm       | 1 |  |
| 23411 | 125 mm       | 1 |  |
| 23412 | 150 mm       | 1 |  |



**MENGHINA CU BAZA MOBILA**

- maxilarul întărit

| Nu.   | specificație |   |  |
|-------|--------------|---|--|
| 23415 | 100 mm       | 1 |  |
| 23416 | 125 mm       | 1 |  |
| 23417 | 150 mm       | 1 |  |



**MINI MENGHINA CU BAZA ROTATIVA**

| Nu.   | specificație |    |
|-------|--------------|----|
| 23407 | 65 mm        | 10 |



**MENGHINA GAURIT**

- maxilarul întărit

| Nu.   | specificație |    |
|-------|--------------|----|
| 23400 | 18   80 mm   | 10 |
| 23401 | 22   100 mm  | 10 |
| 23402 | 24   125 mm  | 5  |



**MINI MENGHINA CU BAZA ROTATIVA 360°**

| ALU   | specificație |    |
|-------|--------------|----|
| 23406 | 80 mm        | 24 |

## CRIC HIDRAULIC TIP BUTELIE

Tija filetata permite prelungirea cursei si ajustarea inaltimei de ridicare. Dotat cu supapa bypass pentru siguranta sporita. Sava zimtata da o aderenta sporita si ofera o zona generoasa de sprijinire.



| Nu.   | Capacitate de incarcare | minimă înălțime | lift   | Ajustati inaltimea | dimensiuni de bază | greutate |   |
|-------|-------------------------|-----------------|--------|--------------------|--------------------|----------|---|
| 26800 | 2 000 kg                | 181mm           | 116 mm | 48 mm              | 88 x 92 mm         | 2,6 kg   | 1 |
| 26801 | 3 000 kg                | 194 mm          | 118 mm | 60 mm              | 92 x 100 mm        | 3,3 kg   | 1 |
| 26802 | 5 000 kg                | 216 mm          | 127 mm | 70 mm              | 96 x 112 mm        | 4,5 kg   | 1 |
| 26803 | 8 000 kg                | 230 mm          | 147 mm | 80 mm              | 103 x 118 mm       | 5,7 kg   | 1 |
| 26804 | 10 000 kg               | 230 mm          | 150 mm | 80 mm              | 110 x 123 mm       | 6,8 kg   | 1 |
| 26805 | 12 000 kg               | 230 mm          | 155 mm | 80 mm              | 116 x 134 mm       | 7,3 kg   | 1 |
| 26806 | 15 000 kg               | 230 mm          | 150 mm | 80 mm              | 133 x 136 mm       | 8,4 kg   | 1 |
| 26807 | 20 000 kg               | 242 mm          | 150 mm | 60 mm              | 144 x 152 mm       | 11 kg    | 1 |



## CRICURI HIDRAULICE DUBLE TIP BUTELIE

Tija filetata permite ajustarea inaltimei de ridicare. Dotate cu supapa bypass pentru o siguranta sporita. Baza lata ofera stabilitate si rezistenta. Toate punctele critice sunt intarite pentru o durabilitate si fiabilitate cat mai mare.



| Nu.   | Capacitate de incarcare | minimă înălțime | lift   | Ajustati inaltimea | greutate |   |
|-------|-------------------------|-----------------|--------|--------------------|----------|---|
| 26815 | 2 000 kg                | 150 mm          | 160 mm | 60 mm              | 4,7 kg   | 1 |
| 26816 | 4 000 kg                | 160 mm          | 170 mm | 60 mm              | 6,4 kg   | 1 |
| 26817 | 6 000 kg                | 215 mm          | 270 mm | -                  | 8,9 kg   | 1 |
| 26819 | 10 000 kg               | 228 mm          | 284 mm | 89 mm              | 10,2 kg  | 1 |



## CRICURI TIP FOARFECA



| Nu.   | Capacitate de incarcare | minimă înălțime | max. înălțime | greutate |   |
|-------|-------------------------|-----------------|---------------|----------|---|
| 26844 | 1 000 kg                | 88 mm           | 380 mm        | 2,5 kg   | 1 |
| 26845 | 2 000 kg                | 120 mm          | 395 mm        | 3,5 kg   | 1 |



## CRICURI HIDRAULICE PORTABILE



| Nu.   | specificatie   | Capacitate de incarcare | minimă înălțime | max. înălțime | greutate |   |
|-------|--|-------------------------|-----------------|---------------|----------|---|
| 26820 | Cric hidraulic portabil                                      | 2 000 kg                | 130 mm          | 345 mm        | 9,6 kg   | 1 |
| 26822 | Cric hidraulic portabil                                      | 3 000 kg                | 130 mm          | 465 mm        | 27,4 kg  | 1 |
| 26826 | Cric hidraulic profil jos pentru service, maner rotativ 360° | 2 000 kg                | 89 mm           | 359 mm        | 14,2 kg  | 1 |
| 26824 | Cric hidraulic service cu pedala                             | 3 000 kg                | 145 mm          | 500 mm        | 37,2 kg  | 1 |
| 26825 | Cric hidraulic portabil profil jos, profi                    | 2 500 kg                | 85 mm           | 455 mm        | 34,8 kg  | 1 |

## SET CRIC HIDRAULIC SI CAPRE REGLABILE

· maner rotativ 360°



| Nu.   | Capacitate de incarcare | minimă înălțime | max. înălțime | greutate    |   |
|-------|-------------------------|-----------------|---------------|-------------|---|
| 26829 | 2 000 kg                | 130 mm          | 350 mm        | 10,5 kg     | 1 |
|       | 2 000 kg                | 275 mm          | 420 mm        | 5 kg (pair) |   |

## CAPRE / STATIVE REGLABILE

1 bucata = 1 pereche.

Ridicare cu clichet și dubla

blocare pentru o protecție sporită. Cadru rezistent la sarcini mari.



| Nu.   | specificație  | Capacitate de incarcare | minimă înălțime | max. înălțime | greutate |   |
|-------|---------------|-------------------------|-----------------|---------------|----------|---|
| 26857 | cu blocaj pin | 2 000 kg                | 275 mm          | 420 mm        | 4,8 kg   | 1 |
| 26858 | cu blocaj pin | 3 000 kg                | 285 mm          | 425 mm        | 6,3 kg   | 1 |
| 26859 | cu blocaj pin | 6 000 kg                | 393 mm          | 593 mm        | 13 kg    | 1 |
| 26853 |               | 12 000 kg               | 465 mm          | 715 mm        | 28 kg    | 1 |

## MACARA HIDRAULICA

Pentru ridicarea și fixarea motoarelor pe timpul montării/demontării.

| Nu.   | Capacitate de incarcare | minimă înălțime | max. înălțime | greutate |   |
|-------|-------------------------|-----------------|---------------|----------|---|
| 26862 | 2 000 kg                | 0               | 2360 mm       | 88 kg    | 1 |



## SUPPORT MOTOR

Suport motor cu echilibrare pentru șasiul mașinii, asigură stabilitatea motorului pe timpul lucrului.

| Nu.   | Capacitate de incarcare | lungime | gamă   | greutate |   |
|-------|-------------------------|---------|--------|----------|---|
| 26871 | 500 kg                  | 1500 mm | 150 mm | 20,3 kg  | 1 |



## CRIC HIDRAULIC PENTRU TRANSMISII

Pentru montarea/demontarea ușoară a transmisiilor și motoarelor.

| Nu.   | specificație                     | capacitate de incarcare | lungime | gamă    | greutate |   |
|-------|----------------------------------|-------------------------|---------|---------|----------|---|
| 26880 | Cric hidraulic pentru transmisii | 500 kg                  | 1100 mm | 1900 mm | 30,0 kg  | 1 |



26880



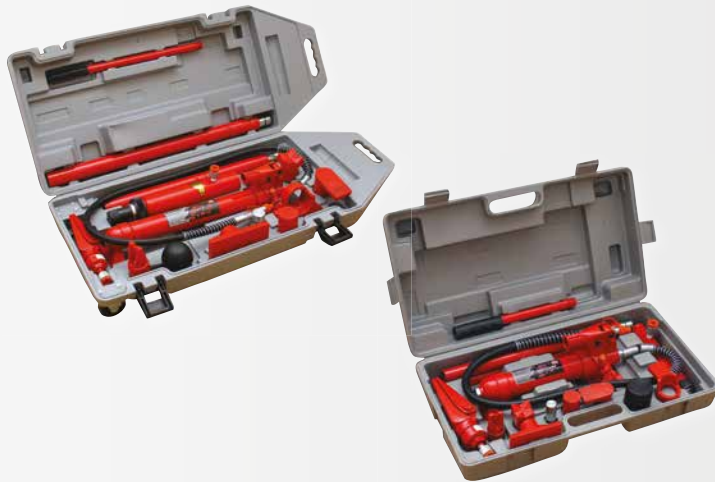

## ECHIPAMENT HIDRAULIC PORTABIL

Echipament hidraulic pentru tinichigerie. Trusa contine un cric hidraulic si 14 accesorii. Este recomandat pentru reparatia caroseriilor fara a avea nevoie de alimentare cu energie. Usor de transportat in trusa.

| Nu.   | Capacitate de incarcare | lift hidraulic | greutate |   |
|-------|-------------------------|----------------|----------|---|
| 26886 | 4 000 kg                | 125 mm         | 17,0 kg  | 1 |
| 26888 | 10 000 kg               | 135 mm         | 32,0 kg  | 1 |



## STATIV MOTOR

Stand mobil pentru montarea si lucrul la demontarea motoarelor. Unitati de prindere universala pentru fixarea motoarelor si rotirea lor.

| Nu.   | Capacitate de incarcare | greutate |   |
|-------|-------------------------|----------|---|
| 26920 | 450 kg                  | 20 kg    | 1 |



## PRESA HIDRAULICA TEVI

| Nu.   | Capacitate | Înălțimea de ridicare | Îndoire potcoava                         | Greutate |   |
|-------|------------|-----------------------|--|----------|---|
| 26895 | 12 000 kg  | 232 mm                | 1½", ¾", 1", 1-1¼", 1-1½", 2"            | 36 kg    | 1 |
| 26896 | 16 000 kg  | 238 mm                | 1½", ¾", 1", 1-1¼", 1-1½", 2", 2-1½", 3" | 65 kg    | 1 |



26897

## PRESA ARCURI

26897 - Pentru a inlocui arcuri direct pe masina.

26943 - Pentru a inlocui arcuri in afara vehiculului. Profile de otel pentru mai multa stabilitate.

| Nu.   | Capacitate maxima | Ø Compressed Spring. | Lungime comprimare | Greutate |   |
|-------|-------------------|----------------------|--------------------|----------|---|
| 26897 | 1 000 kg          | 100-200 mm           | 150 mm             | 24,5 kg  | 1 |
| 26943 | 1 000 kg          | 400 mm               | 210-570 mm         | 35 kg    | 1 |



26943



## EXTRACTOR ULEI CU REZERVOR SI TAVA

Uleiul din baia de ulei poate fi extras prin joja de ulei cu ajutorul colectorului. Pomparea se va face folosind aer comprimat

| Nu.   | Capacitate | Max. presiune | Greutate |   |
|-------|------------|---------------|----------|---|
| 26954 | 90 l       | 0,5 MPa       | 28 kg    | 1 |



## PRESA HIDRAULICA CU CRIC

| Nu.   | Gamă       | Capacitate maxima | Greutate |   |
|-------|------------|-------------------|----------|---|
| 26940 | 0 - 610 mm | 12 000 kg         | 43 kg    | 1 |
| 26941 | 0 - 880 mm | 20 000 kg         | 75 kg    | 1 |

## CRIC HIDRAULIC LUNG



| Nu.   | specificație    | Capacitate | Min.lungime | Max.lungime | Greutate |   |
|-------|-----------------|------------|-------------|-------------|----------|---|
| 26911 | o singură pompă | 5 000 kg   | 620         | 1100        | 12 kg    | 2 |
| 26912 | o singură pompă | 8 000 kg   | 620         | 1100        | 13 kg    | 2 |
| 26914 | pompă dublă     | 5 000 kg   | 620         | 1100        | 12 kg    | 2 |
| 26915 | pompă dublă     | 8 000 kg   | 620         | 1100        | 14 kg    | 2 |

SPARE PARTS FOR  
SANDBLASTING CABINET

| Nu.   | rozméry               |   |
|-------|-----------------------|---|
| 26973 | gloves                | 1 |
| 26974 | nozzles               | 1 |
| 26975 | foil 53,5 x 26 cm     | 1 |
| 26976 | plexiglass 60 x 30 cm | 1 |
| 26977 | glass 60 x 30 cm      | 1 |

## CABINET SABLARE

| Nu.   | Consum de aer  | Dimensiuni exterioare | Dimensiuni interioare | Presiune max | Greutate |   |
|-------|----------------|-----------------------|-----------------------|--------------|----------|---|
| 26972 | 420-710 l/min. | 1500 x 830 x 630 mm   | 600 x 840 x 630 mm    | 8 bar        | 38 kg    | 1 |



## SPALATOR PIESE

Pentru spalare diverse obiecte (piese, accesorii etc.)



| Nu.   | Capacitate rezervor | Capacitate solvent | Debit        | Temperatura max. solvent | Greutate |   |
|-------|---------------------|--------------------|--------------|--------------------------|----------|---|
| 26961 | 90 l                | 45 l               | 10-12 l/min. | 50°C                     | 25 kg    | 1 |
| 26963 | 180l                | 150 l              | 20 l/min     | 50°C                     | 42 kg    | 1 |



## DISPOZITIV DE UNGERE

| Nu.   | specificație |    |
|-------|--------------|----|
| 50020 | 300 ml       | 10 |

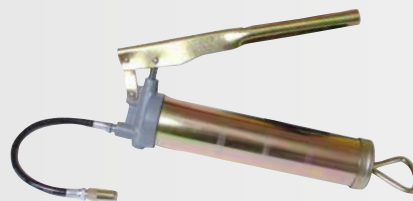

## PISTOL DE VASELINA

- bulk loading
- cartridge loading
- loading with dispenser

| Nu.   | specificație |    |
|-------|--------------|----|
| 50022 | 400 ml       | 20 |



## POMPA PENTRU CANISTRA

| Nu.   |    |
|-------|----|
| 50017 | 10 |



### UNGĂTOR CU ULEI

| Nu.   | specificație |   |
|-------|--------------|---|
| 50019 | 90 ml        | 1 |



### FILTRU

| Nu.   | specificație |   |
|-------|--------------|---|
| 50021 | 60 x 140 mm  | 6 |



### PALNIE FLEXIBILA

| Nu.   | specificație |    |
|-------|--------------|----|
| 50025 | 60 x 140 mm  | 50 |



### FURTUN DE TRANSFER CU SUPAPĂ AUTOAMORSANTĂ

| Nu.   | specificație | ∅     |    |
|-------|--------------|-------|----|
| 50026 | 180 cm       | 15 mm | 24 |



### TAVA MAGNETICA

| Nu.   | specificație |   |
|-------|--------------|---|
| 26996 | 200 x 20 mm  | 1 |

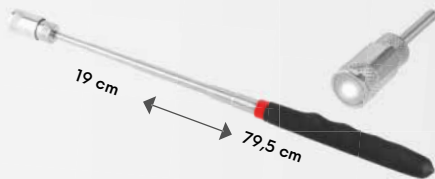

### FESTA

### INSTRUMENT COLECTARE MAGNETIC - LED



| Nu.   | specificație |   |
|-------|--------------|---|
| 13294 |              | 6 |

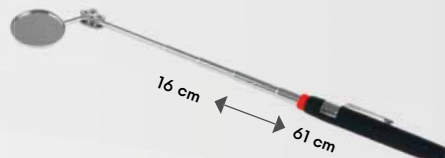

### OGLINA INSPECTIE

| Nu.   | specificație |    |
|-------|--------------|----|
| 13290 |              | 20 |

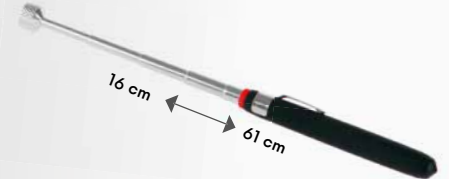

### INSTRUMENT COLECTARE MAGNETIC



| Nu.   | specificație |    |
|-------|--------------|----|
| 13293 |              | 20 |



### UNEALTA CULES GUNOI

· rotativ 90°

| Nu.   | length |    |
|-------|--------|----|
| 61235 | 81 cm  | 12 |

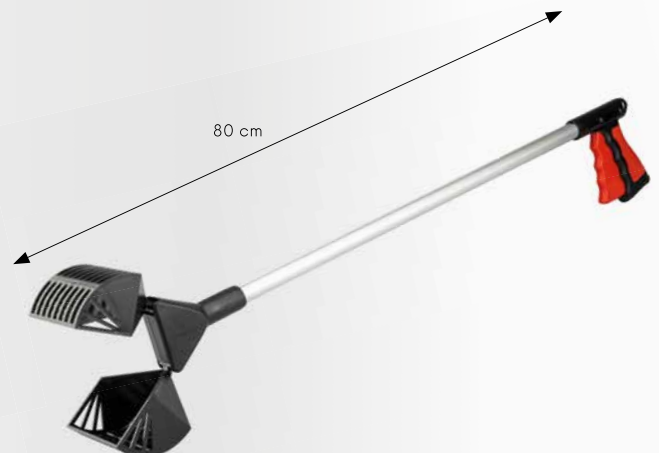

### UNEALTA CULES GUNOI

· max. 4 kg

| Nu.   |    |
|-------|----|
| 61236 | 12 |

# FESTA



**NEW**



**FESTA**  
INDUSTRY

## LED LANTERNA

|       |                 |            |            |                   |         |
|-------|-----------------|------------|------------|-------------------|---------|
| 3xLED | 80, 200, 300 lm | 3W COB LED | USB TYPE C | Li-ion 3.7V 0.8Ah | 120 min |
|       | 0-180°          | 95g        | IK07       | IP54              |         |

| Nu.   | specificatie |
|-------|--------------|
| 37647 | 3,7V 800 mAh |



**FESTA****LED LANTERNA**

| Nu.   | specificatie |         |    |
|-------|--------------|---------|----|
| 37645 | 200 mm       | 3 x AAA | 12 |

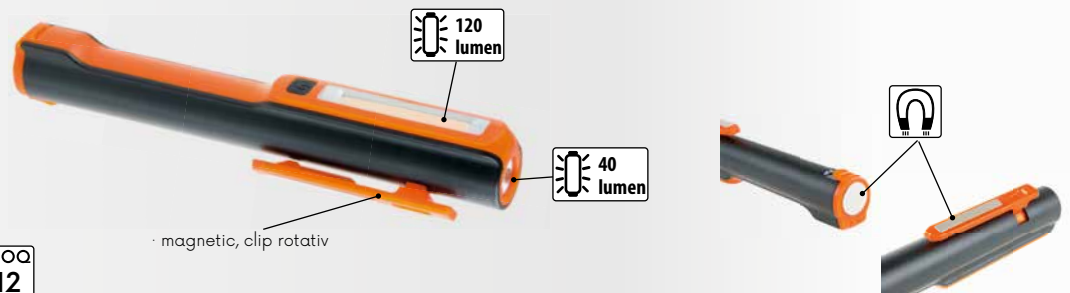
**FESTA****LANTERNA LED PENTRU CAP**

|                     |                                |
|---------------------|--------------------------------|
| greutate            | 47 g                           |
| sursa de lumina     | 1 x 1 W white LED + 2x red LED |
| baterie             | 3 x AAA                        |
| dimensiuni          | 40 x 59 x 32 mm                |
| timpul de iluminare | 45 h                           |
| deschidere          | 120 lumen                      |
| lungimea luminii    | 60 m (100% battery)            |
| programului         | 4                              |

5 pozițiile

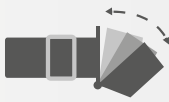

| Nu.   | specificatie                      |  |   |
|-------|-----------------------------------|--|---|
| 37641 | 2 tipuri de lumină, albă și roșie |  | 1 |

**FESTA****LED LANTERNA**

| Nu.   | specificatie |        |    |
|-------|--------------|--------|----|
| 37630 | 185 mm       | 2 x AA | 20 |

**FESTA****LED LANTERNA**

| Nu.   |  |    |
|-------|--|----|
| 37650 |  | 12 |



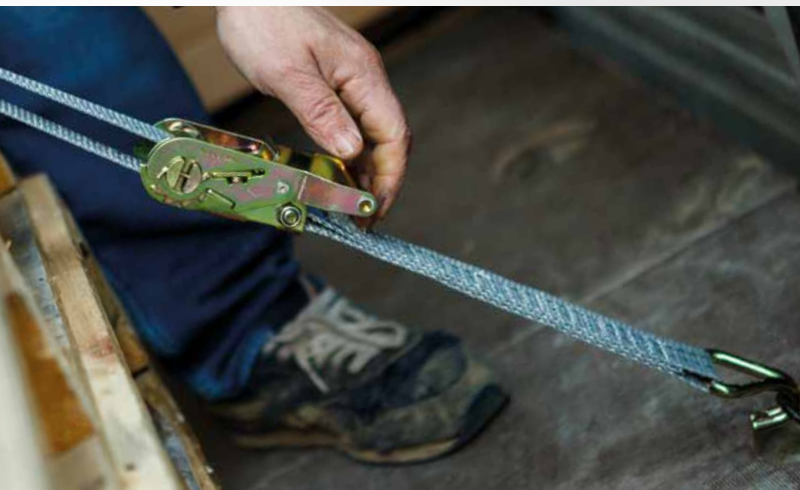

**FESTA**  
CHINGI



2x



| Nu.   | width | length | max.   | buc |    |
|-------|-------|--------|--------|-----|----|
| 51070 | 18 mm | 2 m    | 100 kg | 2   | 12 |

**FESTA**  
CHINGI



| Nu.   | width | length | max.   | buc |   |
|-------|-------|--------|--------|-----|---|
| 51071 | 25 mm | 3,5 m  | 300 kg | 1   | 8 |



**FESTA**  
CHINGI



| Nu.   | width | length | max.   | buc |   |
|-------|-------|--------|--------|-----|---|
| 51072 | 35 mm | 4 m    | 500 kg | 1   | 6 |



**FESTA**  
CHINGI



| Nu.   | width | length | max.    | buc |   |
|-------|-------|--------|---------|-----|---|
| 51040 | 25 mm | 6 m    | 1000 kg | 1   | 1 |
| 51041 | 35 mm | 8 m    | 2000 kg | 1   | 1 |
| 51042 | 35 mm | 8 m    | 3000 kg | 1   | 1 |
| 51043 | 50 mm | 10 m   | 5000 kg | 1   | 1 |



**FESTA**  
CHINGI



2x

| Nu.   | width | length | max.   | buc |   |
|-------|-------|--------|--------|-----|---|
| 51060 | 25 mm | 5 m    | 750 kg | 2   | 5 |



**FESTA**  
CHINGI



| Nu.   | width | length | max.   | buc |   |
|-------|-------|--------|--------|-----|---|
| 51065 | 50 mm | 10 m   | 960 kg | 1   | 6 |



**FESTA**  
CHINGI



| Nu.   | width | length | max.    | buc |   |
|-------|-------|--------|---------|-----|---|
| 51026 | 75 mm | 5 m    | 3000 kg | 1   | 4 |

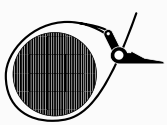

**FESTA**  
CHINGI



| Nu.   | width | length | max.   | buc |   |
|-------|-------|--------|--------|-----|---|
| 51032 | 25 mm | 5 m    | 500 kg | 1   | 6 |



**FESTA**  
CHINGI



| Nu.   | width | length | max.   | buc |    |
|-------|-------|--------|--------|-----|----|
| 51017 | 50 mm | 6 m    | 480 kg | 2   | 5  |
| 51018 | 50 mm | 6 m    | 480 kg | 1   | 10 |



## CHINGI



| Nu.   | width | length | specificatie | buc |
|-------|-------|--------|--------------|-----|
| 51022 | 25 mm | 5 m    | cu cârlige   | 40  |
| 51023 | 50 mm | 5 m    | cu cârlige   | 12  |

## FESTA

## CHINGI



Tapet EVA moale

| Nu.   | width | length | buc |
|-------|-------|--------|-----|
| 51046 | 38 mm | 4 m    | 1   |

## CHINGI



| Nu.   | width | length | specificatie | buc |
|-------|-------|--------|--------------|-----|
| 51030 | 50 mm | 6 m    | cu cârlige   | 20  |
| 51034 | 50 mm | 8 m    | cu cârlige   | 10  |

## CHINGI

2x



| Nu.   | width | length | buc |
|-------|-------|--------|-----|
| 51020 | 25 mm | 2,5 m  | 2   |

## CHINGI



| Nu.   | width | length | buc |
|-------|-------|--------|-----|
| 51045 | 25 mm | 4 m    | 1   |

## COARDE ELASTICA

2x



| Nu.   | length | Ø    | buc |
|-------|--------|------|-----|
| 51013 | 1,2 m  | 8 mm | 2   |

## COARDE ELASTICA



| Nu.   | length | buc |
|-------|--------|-----|
| 51008 | 1 m    | 2   |

## COARDE ELASTICA



| Nu.   | length | Ø     | buc |
|-------|--------|-------|-----|
| 51009 | 1 m    | 10 mm | 1   |

## COARDE ELASTICA

8x

- 2 x 0,4 m
- 2 x 0,6 m
- 1 x 0,8 m
- 1 x 1,0 m



| Nu.   | length | Ø    | buc |
|-------|--------|------|-----|
| 51011 | 1 m    | 8 mm | 8   |

## COARDE ELASTICA

2x



| Nu.   | length | Ø     | buc |
|-------|--------|-------|-----|
| 51001 | 80 cm  | 10 mm | 2   |
| 51002 | 100 cm | 10 mm | 2   |
| 51003 | 150 cm | 10 mm | 2   |
| 51004 | 200 cm | 10 mm | 2   |

## COARDE ELASTICA

2x



| Nu.   | length | Ø    | buc |
|-------|--------|------|-----|
| 51007 | 1 m    | 8 mm | 2   |

## COARDE ELASTICA



| Nu.   | length | Ø    | specificatie | buc |
|-------|--------|------|--------------|-----|
| 51010 | 80 cm  | 8 mm | 8 linia      | 50  |

## PLASA ELASTICE



| Nu.   | length | width  |    |
|-------|--------|--------|----|
| 51015 | 80 cm  | 120 cm | 20 |

BANDA ELASTICA  
PENTRU FIXARE BAGAJE

| Nu.   | length | ∅     |    |
|-------|--------|-------|----|
| 51036 | 20 m   | 8 mm  | 10 |
| 51037 | 20 m   | 10 mm | 6  |

## CÂRLIGE



| 20x   |       |    |
|-------|-------|----|
| Nu.   | ∅     |    |
| 51038 | 10 mm | 30 |

## CARABINE ALUMINIU



| ALU   |       |        | MOQ<br>2 |
|-------|-------|--------|----------|
| Nu.   | ∅     | length |          |
| 51200 | 6 mm  | 60 mm  | 2        |
| 51202 | 7 mm  | 70 mm  | 2        |
| 51201 | 8 mm  | 80 mm  | 2        |
| 51203 | 10 mm | 100 mm | 2        |

## FRANGHIE



| Nu.   | length | ∅     |   |
|-------|--------|-------|---|
| 50915 | 5 m    | 8 mm  | 1 |
| 50916 | 25 m   | 8 mm  | 1 |
| 50917 | 25 m   | 10 mm | 1 |
| 50918 | 25 m   | 12 mm | 1 |
| 50919 | 25 m   | 14 mm | 1 |

## SNUR NYLON



| Nu.   | length | ∅      |    |
|-------|--------|--------|----|
| 51055 | 80 m   | 1,5 mm | 50 |
| 51056 | 50 m   | 2 mm   | 50 |
| 51057 | 20 m   | 4 mm   | 50 |

## FRANGHIE NYLON



| Nu.   | length | ∅     |    |
|-------|--------|-------|----|
| 51050 | 50 m   | 8 mm  | 10 |
| 51051 | 50 m   | 10 mm | 4  |

## FIR PP



| Nu.   | masa  |     |
|-------|-------|-----|
| 50905 | 80 g  | 80  |
| 50906 | 100 g | 100 |
| 50907 | 200 g | 50  |

## FIR PP



| Nu.   | masa            |   |
|-------|-----------------|---|
| 50909 | 500 g (250 m)   | 1 |
| 50910 | 1000 g (500 m)  | 1 |
| 50911 | 5000 g (2500 m) | 1 |

## FIR IUTA



| Nu.   | masa          |   |
|-------|---------------|---|
| 50900 | 80 g (61 m)   | 1 |
| 50901 | 100 g (76 m)  | 1 |
| 50902 | 200 g (153 m) | 1 |

## SFOARA



| Nu.   | length | ∅    |    |
|-------|--------|------|----|
| 50920 | 50 m   | 1 mm | 80 |

## SÂRMĂ DE FIXARE



| 1000x |               |   |
|-------|---------------|---|
| Nu.   | specificație  |   |
| 42365 | 1,25   100 mm | 1 |
| 42366 | 1,25   125 mm | 1 |
| 42367 | 1,25   140 mm | 1 |
| 42368 | 1,25   160 mm | 1 |

## UNEALTA LEGAT ARMATURA



| Nu.   | specificație |    |
|-------|--------------|----|
| 50052 |              | 12 |
| 50050 |              | 1  |

## UNEALTA LEGAT ARMATURA



| Nu.   | specificație |   |
|-------|--------------|---|
| 50051 |              | 2 |





## BRIDE PLASTIC

| <b>50x</b> |  | EN 50146<br>nylon |  |
|------------|---|-------------------|---|
| Nu.        | length  | width             |  |
| 23875      | 120 mm  | 4,8 mm            | 1   |





## BRIDE PLASTIC, COLORATE

| <b>100x</b> |  | EN 50146<br>nylon |  |
|-------------|---|-------------------|---|
| Nu.         | length  | width             |  |
| 23880       | 100 mm  | 2,5 mm            | 1   |
| 23882       | 150 mm  | 2,5 mm            | 1   |
| 23884       | 200 mm  | 3,6 mm            | 1   |



## BRIDE PLASTIC CABLURI

| <b>50x</b> |  | EN 50146<br>nylon |  |
|------------|---|-------------------|---|
| Nu.        | length  | width             |  |
| 23850      | 120 mm  | 2,5 mm            | 1   |
| 23854      | 200 mm  | 3,6 mm            | 1   |
| 23856      | 250 mm  | 3,6 mm            | 1   |
| 23858      | 250 mm  | 4,8 mm            | 1   |
| 23860      | 300 mm  | 4,8 mm            | 1   |
| 23864      | 400 mm  | 4,8 mm            | 1   |
| 23866      | 500 mm  | 4,8 mm            | 1   |
| 23868      | 400 mm  | 7,6 mm            | 1   |
| 23870      | 500 mm  | 7,6 mm            | 1   |



## BRIDE PLASTIC CABLURI

| <b>50x</b> |  | EN 50146<br>nylon |  |
|------------|---|-------------------|---|
| Nu.        | length  | width             |  |
| 23810      | 120 mm  | 2,5 mm            | 1   |
| 23814      | 200 mm  | 3,6 mm            | 1   |
| 23816      | 250 mm  | 3,6 mm            | 1   |
| 23818      | 250 mm  | 4,8 mm            | 1   |
| 23820      | 300 mm  | 4,8 mm            | 1   |
| 23824      | 400 mm  | 4,8 mm            | 1   |
| 23826      | 500 mm  | 4,8 mm            | 1   |
| 23828      | 400 mm  | 7,6 mm            | 1   |
| 23830      | 500 mm  | 7,6 mm            | 1   |



## CURELE CU MÂNER

| <b>10x</b> |  |        |   |
|------------|---|--------|--|
| Nu.        | length  | width  |  |
| 23865      | 160 mm  | 7,5 mm | 1  |



## FOLIE DE AMBALAJ

|  |        |         |            |             |   |
|---|--------|---------|------------|-------------|---|
| Nu.   | lățime | lungime | grosime    |             |  |
| 38095   | 500 mm | 600 m   | 8 $\mu$ m  | transparent | 1   |
| 38097   | 100 mm | 150 m   | 20 $\mu$ m | transparent | 1   |
| 38096   | 500 mm | 200 m   | 23 $\mu$ m | negru       | 1   |



## SAL GUNOI CONSTRUCTII

|  |        |         |         |        |     |   |
|---|--------|---------|---------|--------|-----|---|
| Nu.   | lățime | lungime | grosime | volume | buc |  |
| 39194   | 500 mm | 1100 mm | 0,16 mm | 100 l  | 1   | 10  |
| 39196   | 600 mm | 1200 mm | 0,16 mm | 110 l  | 1   | 10  |
| 39198   | 700 mm | 1100 mm | 0,16 mm | 120 l  | 1   | 10  |
| 39200   | 500 mm | 1100 mm | 0,20 mm | 100 l  | 1   | 10  |
| 39202   | 600 mm | 1200 mm | 0,20 mm | 110 l  | 1   | 10  |
| 39204   | 700 mm | 1100 mm | 0,20 mm | 120 l  | 1   | 10  |



## SAL GUNOI CONSTRUCTII

|  |        |         |         |        |     |   |
|---|--------|---------|---------|--------|-----|---|
| Nu.   | lățime | lungime | grosime | volume | buc |  |
| 39195   | 500 mm | 1100 mm | 0,16 mm | 100 l  | 1   | 10  |
| 39197   | 600 mm | 1200 mm | 0,16 mm | 110 l  | 1   | 10  |
| 39199   | 700 mm | 1100 mm | 0,16 mm | 120 l  | 1   | 10  |
| 39201   | 500 mm | 1100 mm | 0,20 mm | 100 l  | 1   | 10  |
| 39203   | 600 mm | 1200 mm | 0,20 mm | 110 l  | 1   | 10  |
| 39205   | 700 mm | 1100 mm | 0,20 mm | 120 l  | 1   | 10  |



## SAC GUNOI

|  |        |         |         |     |   |
|---|--------|---------|---------|-----|---|
| Nu.   | lățime | lungime | grosime | buc |  |
| 38060   | 700 mm | 1100 mm | 0,08 mm | 10  | 1   |
| 38063   | 700 mm | 1100 mm | 0,10 mm | 3   | 1   |
| 38065   | 700 mm | 1100 mm | 0,20 mm | 3   | 1   |



## SAC GUNOI

|  |        |         |         |     |   |
|---|--------|---------|---------|-----|---|
| Nu.   | lățime | lungime | grosime | buc |  |
| 38050   | 500 mm | 600 mm  | 0,04 mm | 25  | 1   |
| 38052   | 600 mm | 800 mm  | 0,04 mm | 25  | 1   |
| 38054   | 700 mm | 1100 mm | 0,04 mm | 25  | 1   |



## SAC GUNOI

| <b>5x</b> |  |         |         |   |
|-----------|---|---------|---------|---|
| Nu.       | lățime  | lungime | grosime |  |
| 38055     | 1200 mm   | 1000 mm | 0,08 mm | 5   |

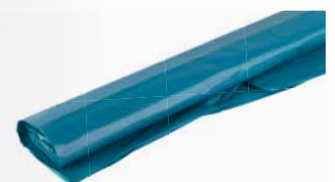



**BANDA AVERTIZARE -  
LINIE DE ALIMENTARE**

| Nu.   | lățime | lungime |   |
|-------|--------|---------|---|
| 38955 | 22 cm  | 20 m    | 1 |
| 38956 | 22 cm  | 50 m    | 1 |



**BANDA AVERTIZARE -  
APĂ**

| Nu.   | lățime | lungime |   |
|-------|--------|---------|---|
| 38957 | 22 cm  | 20 m    | 1 |
| 38958 | 22 cm  | 50 m    | 1 |



**BANDA AVERTIZARE -  
GAZ**

| Nu.   | lățime | lungime |   |
|-------|--------|---------|---|
| 38959 | 22 cm  | 20 m    | 1 |
| 38960 | 22 cm  | 50 m    | 1 |



**BANDA AVERTIZARE**

| Nu.   | specificație      | lungime     |   |
|-------|-------------------|-------------|---|
| 38944 | ZÁKAZ VSTUPU, SK  | 80 mm 250 m | 8 |
| 38945 | VSTUP ZAKÁZÁN, CZ | 80 mm 250 m | 8 |



**BANDA AVERTIZARE**

| Nu.   | lungime     |   |
|-------|-------------|---|
| 38948 | 80 mm 250 m | 8 |

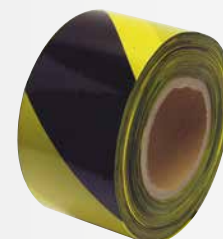

**BANDA AVERTIZARE**

| Nu.   | lungime     |   |
|-------|-------------|---|
| 38946 | 80 mm 250 m | 8 |



**BANDA AVERTIZARE**

| Nu.   | lungime    | specificație |    |
|-------|------------|--------------|----|
| 38947 | 48 mm 33 m | dreapta      | 48 |
| 38961 | 48 mm 33 m | stânga       | 48 |



**BANDA MARCARE**

| Nu.   | lățime | lungime | grosime |    |
|-------|--------|---------|---------|----|
| 38949 | 50 mm  | 50 m    | 0,15 mm | 36 |

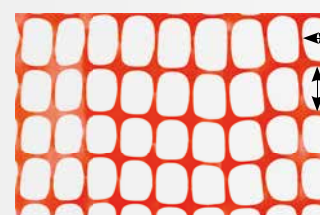

cca 3,5 cm

cca 6,5 cm

**PLASA PLASTIC**

140 g/m<sup>2</sup> UV STABLE

| Nu.   | specificație                        |   |
|-------|-------------------------------------|---|
| 42190 | 1,2 x 50 m HDPE 140g/m <sup>2</sup> | 1 |



**BENZI PVC**

5x

| Nu.   | lățime | lungime | grosime |     |
|-------|--------|---------|---------|-----|
| 38931 | 19 mm  | 5 m     | 0,13 mm | 100 |



**BANDA NEAGRA PVC**

| Nu.   | lățime | lungime | grosime |    |
|-------|--------|---------|---------|----|
| 38932 | 19 mm  | 10 m    | 0,13 mm | 10 |



**PVC BENZI**

| Nu.   | lățime | lungime | grosime |    |
|-------|--------|---------|---------|----|
| 38925 | 19 mm  | 10 m    | 0,13 mm | 10 |



**BANDA NEAGRA PVC**

| Nu.   | lățime | lungime | grosime |    |
|-------|--------|---------|---------|----|
| 38968 | 19 mm  | 10 m    | 0,19 mm | 10 |

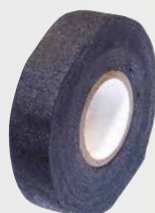

**BANDA NEAGRA RANFORSATA**

| Nu.   | lățime | lungime |    |
|-------|--------|---------|----|
| 38927 | 19 mm  | 10 m    | 10 |



**BANDA NEAGRA RANFORSATA**

| Nu.   | lățime | lungime |    |
|-------|--------|---------|----|
| 38980 | 48 mm  | 10 m    | 24 |
| 38981 | 48 mm  | 20 m    | 24 |



## BANDA DUBLU ADEZIVA

| Nu.   | lățime | lungime |   |
|-------|--------|---------|---|
| 38924 | 50 mm  | 10 m    | 1 |
| 38964 | 50 mm  | 25 m    | 1 |

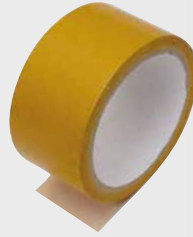

## BANDA DUBLU ADEZIVA

PP  
Polypropylen

| Nu.   | lățime | lungime |   |
|-------|--------|---------|---|
| 38929 | 50 mm  | 10 m    | 1 |
| 38966 | 50 mm  | 25 m    | 1 |



## BANDA DUBLU ADEZIVA

MADE IN  
EU

| Nu.   | lățime | lungime |    |
|-------|--------|---------|----|
| 38990 | 19 mm  | 5 m     | 48 |
| 38991 | 25 mm  | 5 m     | 36 |



## BANDA ADEZIVA PROFESIONALA

MADE IN  
EU

| Nu.   | lățime | lungime |    |
|-------|--------|---------|----|
| 38995 | 48 mm  | 25 m    | 24 |



## BANDA ALU-TEX

| Nu.   | lățime | lungime |    |
|-------|--------|---------|----|
| 38965 | 30 mm  | 10 m    | 1  |
| 38928 | 50 mm  | 10 m    | 72 |
| 38934 | 50 mm  | 45 m    | 24 |



blue dolphin tapes

## BANDA ADEZIVA PROFESIONALA

MADE IN  
EU

| Nu.   | lățime | lungime |    |
|-------|--------|---------|----|
| 37275 | 48 mm  | 50 m    | 24 |



blue dolphin tapes

## BANDA MASCARE

UV STABLE  
MADE IN  
EU

| Nu.   | lățime | lungime |    |
|-------|--------|---------|----|
| 37271 | 38 mm  | 20 m    | 24 |
| 37270 | 48 mm  | 20 m    | 24 |
| 37272 | 48 mm  | 50 m    | 24 |



blue dolphin tapes

## BANDA PLASTIC MASCARE GEAMURI

for 30 days

UV STABLE  
MADE IN  
EU

| Nu.   | lățime | lungime |    |
|-------|--------|---------|----|
| 37273 | 48 mm  | 50 m    | 24 |

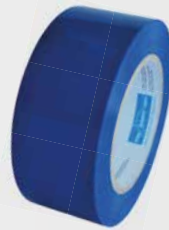

blue dolphin tapes

## BANDA HARTIE MASCARE PROFI

MADE IN  
EU

| Nu.   | lățime | lungime |    |
|-------|--------|---------|----|
| 37263 | 38 mm  | 50 m    | 24 |
| 37264 | 48 mm  | 50 m    | 24 |

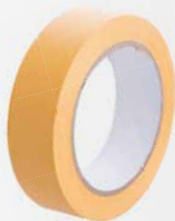

## PVC BANDA DUBLU

MADE IN  
EU

| Nu.   | lățime | lungime |    |
|-------|--------|---------|----|
| 37266 | 30 mm  | 33 m    | 60 |
| 37267 | 38 mm  | 33 m    | 48 |
| 37268 | 50 mm  | 33 m    | 36 |



## BANDA ADEZIVA PENTRU MASCARE

MADE IN  
EU

| Nu.   | lățime | lungime |    |
|-------|--------|---------|----|
| 37255 | 19 mm  | 50 m    | 12 |
| 37256 | 25 mm  | 50 m    | 12 |
| 37257 | 30 mm  | 50 m    | 7  |
| 37258 | 38 mm  | 50 m    | 6  |
| 37259 | 50 mm  | 50 m    | 6  |



## BANDA PVC

MADE IN  
EU

| Nu.   | lățime | lungime |    |
|-------|--------|---------|----|
| 38942 | 50 mm  | 50 m    | 72 |



## BANDĂ PLACATĂ



| Nu.   | lățime | lungime |   |
|-------|--------|---------|---|
| 38972 | 50 mm  | 50 m    | 1 |
| 38973 | 50 mm  | 100 m   | 1 |



## BANDA ADEZIVA DE ALUMINIU

ALU

| Nu.   | lățime | lungime |    |
|-------|--------|---------|----|
| 38963 | 48 mm  | 10 m    | 1  |
| 38943 | 48 mm  | 45 m    | 24 |



## BANDA ANTI-ALUNECARE

| Nu.   | lățime | lungime | grosime |    |
|-------|--------|---------|---------|----|
| 37280 | 25 mm  | 15 m    | 0,8 mm  | 72 |
| 37281 | 50 mm  | 15m     | 0,8 mm  | 36 |



## BANDA ADEZIVA

| Nu.   | lățime | lungime |     |
|-------|--------|---------|-----|
| 38930 | 19 mm  | 5 m     | 100 |



## BANDA ADEZIVA PENTRU GIPS CARTON

| Nu.   | lățime | lungime |    |
|-------|--------|---------|----|
| 38935 | 50 mm  | 20 m    | 60 |
| 38937 | 50 mm  | 45 m    | 36 |
| 38939 | 50 mm  | 90 m    | 24 |
| 38940 | 50 mm  | 153 m   | 24 |



## BANDA FIBRA



| Nu.   | lățime | lungime |    |
|-------|--------|---------|----|
| 38941 | 50 mm  | 25 m    | 40 |



## BANDA TEFLON

| Nu.   | lățime | lungime | grosime |    |
|-------|--------|---------|---------|----|
| 38969 | 19 mm  | 15 m    | 0,2 mm  | 10 |



## BANDA TEFLON

| Nu.   | lățime | lungime | grosime  |    |
|-------|--------|---------|----------|----|
| 38933 | 12 mm  | 10 m    | 0,075 mm | 10 |



## BANDA TEFLON

· pentru instalații de apă și gaze

| Nu.   | lățime | lungime |    |
|-------|--------|---------|----|
| 38926 | 2 mm   | 150 m   | 20 |

FESTA

## BANDA TEFLON

· 160m  
 · -20°C ... +130°C  
 · max 16 bar

NEW



| Nu.   | specificație |   |
|-------|--------------|---|
| 38975 |              | 1 |



## DISTRIBUITOR DE BANDĂ DE AMBALARE

| Nu.   |  |   |
|-------|--|---|
| 38985 |  | 1 |



## BANDĂ CU SCAI

| Nu.   | specificație |   |
|-------|--------------|---|
| 45471 | 12 mm x 5 m  | 1 |



FESTA

## BANDĂ CU SCAI 3 BUC

| Nu.   | lățime | lungime |   |
|-------|--------|---------|---|
| 37295 | 20 mm  | 150 mm  | 1 |
| 37296 | 20 mm  | 200 mm  | 1 |
| 37297 | 20 mm  | 250 mm  | 1 |

CATARAMA  
CORDELINA

DIN 1480 Zn



| Nu.   | specificatie |    |
|-------|--------------|----|
| 50100 | 5 x 70 mm    | 10 |
| 50101 | 6 x 90 mm    | 10 |
| 50102 | 8 x 125 mm   | 10 |
| 50103 | 10 x 150 mm  | 10 |

| Nu.   | specificatie |    |
|-------|--------------|----|
| 50104 | 12 x 200 mm  | 10 |
| 50106 | 16 x 230 mm  | 10 |
| 50108 | 20 x 220 mm  | 10 |

## CARABINE

DIN 5299 C Zn



| Nu.   | specificatie |    |
|-------|--------------|----|
| 51204 | 4 mm         | 10 |
| 51205 | 5 mm         | 10 |
| 51206 | 6 mm         | 10 |
| 51207 | 7 mm         | 10 |
| 51208 | 8 mm         | 10 |

| Nu.   | specificatie |    |
|-------|--------------|----|
| 51209 | 9 mm         | 10 |
| 51210 | 10 mm        | 10 |
| 51211 | 11 mm        | 10 |
| 51212 | 12 mm        | 10 |

## CUPLAJ RAPID

Zn



| Nu.   | specificatie |    |
|-------|--------------|----|
| 51241 | 4 mm         | 10 |
| 51242 | 5 mm         | 10 |
| 51243 | 6 mm         | 10 |
| 51244 | 7 mm         | 10 |

| Nu.   | specificatie |    |
|-------|--------------|----|
| 51245 | 8 mm         | 10 |
| 51246 | 10 mm        | 10 |
| 51247 | 12 mm        | 10 |

## CARLIG

Zn



| Nu.   | specificatie |    |
|-------|--------------|----|
| 51271 | 3 mm         | 10 |
| 51272 | 4 mm         | 10 |
| 51273 | 5 mm         | 10 |
| 51274 | 6 mm         | 10 |

| Nu.   | specificatie |    |
|-------|--------------|----|
| 51275 | 7 mm         | 10 |
| 51276 | 8 mm         | 10 |
| 51278 | 10 mm        | 10 |

## PIULITA-INEL

DIN 5820 Zn



| Nu.   | specificatie |    |
|-------|--------------|----|
| 51320 | 6 mm         | 10 |
| 51321 | 8 mm         | 10 |
| 51322 | 10 mm        | 10 |
| 51323 | 12 mm        | 10 |

| Nu.   | specificatie |    |
|-------|--------------|----|
| 51324 | 14 mm        | 10 |
| 51325 | 16 mm        | 10 |
| 51327 | 20 mm        | 10 |

## SURUB CAP-INEL

DIN 5820 Zn



| Nu.   | specificatie |    |
|-------|--------------|----|
| 51300 | 6 mm         | 10 |
| 51301 | 8 mm         | 10 |
| 51302 | 10 mm        | 10 |
| 51303 | 12 mm        | 10 |
| 51304 | 14 mm        | 10 |

| Nu.   | specificatie |    |
|-------|--------------|----|
| 51305 | 16 mm        | 10 |
| 51306 | 18 mm        | 10 |
| 51307 | 20 mm        | 10 |
| 51308 | 22 mm        | 10 |



## CARABINE ALUMINIU

Zn

| Nu.   | specificatie |    |
|-------|--------------|----|
| 51220 | 53 mm        | 10 |
| 51221 | 67 mm        | 10 |
| 51222 | 76 mm        | 10 |



## INEL

Zn

| Nu.   | specificatie |    |
|-------|--------------|----|
| 51225 | 3,8 mm       | 10 |
| 51226 | 4,5 mm       | 10 |
| 51227 | 6,0 mm       | 10 |

CONECTOR FRANGHII  
SI CABLURI

DIN 5685 C Zn

| Nu.   | specificatie |    |
|-------|--------------|----|
| 51341 | Ø 10 mm      | 10 |



## CLEMA FRANGHIE

Zn

| Nu.   | specificatie |    |
|-------|--------------|----|
| 51280 | 3 mm         | 10 |
| 51281 | 5 mm         | 10 |
| 51282 | 6 mm         | 10 |
| 51283 | 8 mm         | 10 |
| 51284 | 10 mm        | 10 |
| 51286 | 12 mm        | 10 |
| 51287 | 14 mm        | 10 |
| 51288 | 16 mm        | 10 |



## INELE SIGURANTA FRANGHII

Zn

| Nu.   | specificatie |    |
|-------|--------------|----|
| 51258 | Ø 16 mm      | 10 |
| 51259 | Ø 18 mm      | 10 |
| 51260 | Ø 20 mm      | 10 |
| 51261 | Ø 22 mm      | 10 |
| 51262 | Ø 24 mm      | 10 |
| 51264 | Ø 28 mm      | 10 |

## LANT CU PIEDICA

| Nu.   | Capacitate | Inaltime min. | Inaltime ridicare | Numar piedica lant | Grosime lant | Greutate |  |
|-------|------------|---------------|-------------------|--------------------|--------------|----------|---|
| 26700 | 500 kg     | 280 mm        | 3 000 mm          | 1                  | 6 mm         | 7,5 kg   | 1   |
| 26701 | 1 000 kg   | 300 mm        | 3 000 mm          | 1                  | 6 mm         | 9 kg     | 1   |
| 26702 | 2 000 kg   | 380 mm        | 3 000 mm          | 2                  | 6 mm         | 12 kg    | 1   |



## CRIC FIXARE CHINGI

| Nu.   | specificatie |  |
|-------|--------------|---|
| 50035 | 2 t          | 6   |
| 50036 | 4 t          | 4   |



## LANT OCHIURI SCURTE

DIN 5685 A Zn

| Nu.   | dimens. ochiului | lungime |  |
|-------|------------------|---------|---|
| 51402 | 2 x 10 mm        | 110 m   | 1   |
| 51403 | 3 x 16 mm        | 60 m    | 1   |
| 51404 | 4 x 21 mm        | 40 m    | 1   |
| 51405 | 5 x 23 mm        | 30 m    | 1   |



| Nu.   | dimens. ochiului | lungime |  |
|-------|------------------|---------|---|
| 51406 | 6 x 24 mm        | 18 m    | 1   |
| 51407 | 7 x 50 mm        | 16 m    | 1   |
| 51408 | 8 x 32 mm        | 10 m    | 1   |
| 51410 | 10 x 39 mm       | 10 m    | 1   |

## LANT VICTOR

DIN 5686 Zn

| Nu.   | Ø      | lungime |  |
|-------|--------|---------|---|
| 51430 | 1,4 mm | 150 m   | 1   |
| 51431 | 1,6 mm | 150 m   | 1   |
| 51432 | 1,8 mm | 130 m   | 1   |



| Nu.   | Ø      | lungime |  |
|-------|--------|---------|---|
| 51433 | 2,0 mm | 118 m   | 1   |
| 51435 | 2,5 mm | 70 m    | 1   |
| 51436 | 2,8 mm | 50 m    | 1   |

## LANT OCHIURI LUNGI

DIN 5685 C Zn

| Nu.   | dimens. ochiului | lungime |  |
|-------|------------------|---------|---|
| 51412 | 2 x 12 mm        | 80 m    | 1   |
| 51413 | 3 x 26 mm        | 60 m    | 1   |
| 51414 | 4 x 32 mm        | 38 m    | 1   |
| 51415 | 5 x 35 mm        | 32 m    | 1   |



| Nu.   | dimens. ochiului | lungime |  |
|-------|------------------|---------|---|
| 51416 | 6 x 43 mm        | 18 m    | 1   |
| 51417 | 7 x 50 mm        | 16 m    | 1   |
| 51418 | 8 x 54 mm        | 10 m    | 1   |
| 51420 | 10 x 65 mm       | 10 m    | 1   |

## LANT DE PLASTIC



| Nu.   | specificatie       |  |
|-------|--------------------|--|
| 51450 | 6 mm 25 m rosu alb | 1  |



## TROLIU MANUAL

Zn

| Nu.   | load capacity | rope lungime |  |
|-------|---------------|--------------|---|
| 26720 | 300 kg        | 8 m          | 1   |
| 26705 | 450 kg        | 8 m          | 1   |
| 26721 | 500 kg        | 8 m          | 1   |
| 26722 | 800 kg        | 8 m          | 1   |
| 26706 | 900 kg        | 8 m          | 1   |
| 26707 | 1350 kg       | 8 m          | 1   |



## STAND PROMOTIONAL

| Nu.   | specificatie                            |  |
|-------|---|---|
| 51196 | Stand pentru lanțuri umplute            | 10  |
| 51197 | Stand pentru frânghiile umplute fi lled | 10  |
| 51198 | Standuri promoționale pentru lanțuri    | 10  |
| 51199 | Standuri promoționale pentru corzi      | 10  |



## CABLU IMPLETIT DE OTEL GALVANIZAT

Zn

| Nu.   | lungime        |  |
|-------|----------------|---|
| 51100 | Ø 1 mm 500 m   | 1   |
| 51102 | Ø 1,5 mm 500 m | 1   |
| 51103 | Ø 2 mm 200 m   | 1   |
| 51104 | Ø 3 mm 200 m   | 1   |
| 51105 | Ø 4 mm 100 m   | 1   |
| 51106 | Ø 5 mm 75 m    | 1   |
| 51107 | Ø 6 mm 75 m    | 1   |
| 51130 | Ø 8 mm 75 m    | 1   |
| 51131 | Ø 10 mm 50 m   | 1   |
| 51132 | Ø 12 mm 50 m   | 1   |



## CABLU IMPLETIT DE OTEL MANTA PVC

Zn

| Nu.   | lungime        |  |
|-------|----------------|--|
| 51108 | Ø 2/3 mm 200 m | 1  |
| 51109 | Ø 3/4 mm 100 m | 1  |
| 51110 | Ø 4/5 mm 75 m  | 1  |
| 51111 | Ø 5/6 mm 50 m  | 1  |



## CABLU IMPLETIT DE OTEL INOX

INOX

| Nu.   | lungime        |  |
|-------|----------------|---|
| 51120 | Ø 1 mm 300 m   | 1   |
| 51121 | Ø 1,2 mm 300 m | 1   |
| 51122 | Ø 1,5 mm 300 m | 1   |
| 51123 | Ø 2 mm 200 m   | 1   |
| 51124 | Ø 3 mm 200 m   | 1   |
| 51125 | Ø 4 mm 100 m   | 1   |
| 51126 | Ø 5 mm 75 m    | 1   |
| 51127 | Ø 6 mm 75 m    | 1   |





## TIJA FILETATA

## TIJA FILETATA

**DIN 975** **Zn**

**4.8** · fok tarie

| Nu.   | specificatie |  |     |
|-------|--------------|--|-----|
| 55040 | M 4 1 m      |  | 200 |
| 55050 | M 5 1 m      |  | 150 |
| 55060 | M 6 1 m      |  | 100 |
| 55080 | M 8 1 m      |  | 50  |
| 55100 | M 10 1 m     |  | 20  |
| 55120 | M 12 1 m     |  | 20  |
| 55140 | M 14 1 m     |  | 15  |
| 55160 | M 16 1 m     |  | 15  |
| 55180 | M 18 1 m     |  | 10  |
| 55200 | M 20 1 m     |  | 10  |
| 55220 | M 22 1 m     |  | 5   |
| 55240 | M 24 1 m     |  | 5   |
| 55300 | M 30 1 m     |  | 5   |

**DIN 976** **INOX** **4.8** · fok tarie

| Nu.   | specificatie |  |    |
|-------|--------------|--|----|
| 55315 | M 12 1 m     |  | 20 |
| 55316 | M 14 1 m     |  | 15 |
| 55317 | M 16 1 m     |  | 15 |
| 55318 | M 18 1 m     |  | 10 |
| 55319 | M 20 1 m     |  | 10 |



before after



## TIJA FILETATA

**DIN 975** **4.8** · fok tarie

| Nu.   | specificatie |  |     |
|-------|--------------|--|-----|
| 55051 | M 5 1 m      |  | 150 |
| 55181 | M 18 1 m     |  | 10  |
| 55201 | M 20 1 m     |  | 10  |
| 55221 | M 22 1 m     |  | 5   |



**FESTA**

## CURATATOR DE MARGINI

Ø 3 - 19 mm

1/4"

| Nu.   | Specificatie |  |   |
|-------|--------------|--|---|
| 16321 |              |  | 5 |



## PIULITE HEXAGONALE

**DIN 934** **Zn**

**4.8** · fok tarie

| Nu.   | specificatie |   |  |
|-------|--------------|---|--|
| 55350 | M 4 100 buc  | 1 |  |
| 55351 | M 5 100 buc  | 1 |  |
| 55352 | M 6 100 buc  | 1 |  |
| 55353 | M 8 100 buc  | 1 |  |
| 55354 | M 10 100 buc | 1 |  |
| 55355 | M 12 100 buc | 1 |  |
| 55356 | M 14 100 buc | 1 |  |
| 55357 | M 16 100 buc | 1 |  |
| 55358 | M 18 100 buc | 1 |  |
| 55359 | M 20 10 buc  | 1 |  |
| 55360 | M 22 10 buc  | 1 |  |
| 55361 | M 24 10 buc  | 1 |  |
| 55362 | M 30 10 buc  | 1 |  |



## SAIBA DIN 440R ZN

**DIN 440R** **Zn**



| Nu.   | specificatie |   |  |
|-------|--------------|---|--|
| 55331 | M 5 100 buc  | 1 |  |
| 55332 | M 6 100 buc  | 1 |  |
| 55333 | M 8 100 buc  | 1 |  |
| 55334 | M 10 100 buc | 1 |  |
| 55335 | M 12 100 buc | 1 |  |
| 55336 | M 14 100 buc | 1 |  |
| 55337 | M 16 100 buc | 1 |  |
| 55339 | M 20 10 buc  | 1 |  |
| 55340 | M 22 10 buc  | 1 |  |
| 55341 | M 24 10 buc  | 1 |  |
| 55342 | M 30 10 buc  | 1 |  |



**FESTA**

## CUTIE ORGANIZATOR



| Nu.   | Specificatie      |   |  |
|-------|-------------------|---|--|
| 55650 | 375 x 290 x 67 mm | 1 |  |



## SURUB PENTRU LEMN

**2000x**

| Nu.   | specificatie |   |  |
|-------|--------------|---|--|
| 55640 | 2000 buc     | 1 |  |



| buc |             |  |
|-----|-------------|--|
| 350 | 3,0 x 16 mm |  |
| 280 | 3,0 x 20 mm |  |
| 220 | 3,0 x 25 mm |  |
| 250 | 3,5 x 20 mm |  |
| 240 | 3,5 x 25 mm |  |
| 180 | 3,5 x 3, mm |  |
| 280 | 4,0 x 16 mm |  |
| 80  | 4,0 x 30 mm |  |
| 40  | 4,0 x 40 mm |  |
| 30  | 4,0 x 50 mm |  |
| 25  | 5,0 x 50 mm |  |
| 25  | 5,0 x 60 mm |  |

## SURUB PENTRU LEMN + DIBLU PLASTIC, BOX

surub

| buc |             |  |
|-----|-------------|--|
| 40  | 3,5 x 30 mm |  |
| 25  | 4,0 x 40 mm |  |
| 12  | 5,0 x 50 mm |  |
| 8   | 6,0 x 60 mm |  |

diblu

| buc |            |  |
|-----|------------|--|
| 40  | 5 x 25 mm  |  |
| 25  | 6 x 30 mm  |  |
| 12  | 8 x 40 mm  |  |
| 8   | 10 x 50 mm |  |

**170x**

| Nu.   | specificatie |   |  |
|-------|--------------|---|--|
| 55645 |              | 1 |  |



## SURUB PENTRU LEMN

| buc |             |  |
|-----|-------------|--|
| 60  | 3,0 x 12 mm |  |
| 50  | 3,0 x 16 mm |  |
| 40  | 3,0 x 20 mm |  |
| 50  | 3,5 x 20 mm |  |
| 40  | 3,5 x 30 mm |  |
| 25  | 4,0 x 30 mm |  |
| 20  | 4,0 x 40 mm |  |
| 15  | 5,0 x 50 mm |  |
| 10  | 5,0 x 60 mm |  |

**310x**

| Nu.   | specificatie |   |  |
|-------|--------------|---|--|
| 55642 |              | 1 |  |





OCHELARI DE PROTECTIE

CE EN 166

| Nu.   | specificație |    |
|-------|--------------|----|
| 50510 |              | 10 |



ANTIFOANE

CE EN 352 27 dB

| Nu.   | specificație |   |
|-------|--------------|---|
| 50563 |              | 1 |



ANTIFOANE

CE EN 352 27 dB

| Nu.   | specificație |   |
|-------|--------------|---|
| 50564 |              | 1 |



OCHELARI DE PROTECTIE

CE EN 166

| Nu.   | specificație |    |
|-------|--------------|----|
| 50514 |              | 10 |



MASCA PE CU ECRAN PROTECTOR

CE EN 166

| Nu.   | specificație |    |
|-------|--------------|----|
| 50556 |              | 10 |

VIZIERA PROTECTIE

CE EN 1731

| Nu.   | specificație |    |
|-------|--------------|----|
| 50562 |              | 10 |



OCHELARI DE PROTECTIE

Lungimea laterală reglabilă

CE EN 166

| Nu.   | specificație |    |
|-------|--------------|----|
| 50511 |              | 12 |



DOPURI PROTECTIE URECHI

| Nu.   | specificație |     |
|-------|--------------|-----|
| 50560 |              | 100 |



DOPURI PROTECTIE URECHI

| Nu.   | specificație |     |
|-------|--------------|-----|
| 50559 |              | 100 |



OCHELARI DE PROTECTIE

CE EN 170

| Nu.   | specificație |    |
|-------|--------------|----|
| 50512 | tamno        | 12 |



CASCA PROTECTIE CLIMAX

CE EN 397 MADE IN EU

| Nu.   | specificație |    |
|-------|--------------|----|
| 50550 | albastru     | 30 |
| 50551 | roșu         | 30 |
| 50553 | alb          | 30 |
| 50554 | galben       | 30 |



VESTE REFLECTORIZANTE

CE EN 20471

| Nu.   | specificație |     |
|-------|--------------|-----|
| 50570 | portocaliu   | 100 |
| 50571 | galben       | 100 |

OCHELARI DE PROTECTIE

CE EN 166

| Nu.   | specificație |   |
|-------|--------------|---|
| 50513 |              | 1 |







### CARUCIOR GENUCHI

| Nu.   | specificație |   |
|-------|--------------|---|
| 37135 |              | 1 |



**FESTA**

### GENUNCHIERE

| Nu.   | specificație |   |
|-------|--------------|---|
| 37145 | gel          | 8 |



**FESTA**

### GENUNCHIERE

| Nu.   | specificație |    |
|-------|--------------|----|
| 37140 | gel          | 12 |



**FESTA**

### GENUNCHIERE

| Nu.   | specificație |    |
|-------|--------------|----|
| 37144 | gel          | 12 |



**FESTA**

### GENUNCHIERE

| Nu.   | specificație |    |
|-------|--------------|----|
| 37143 |              | 12 |



**FESTA**

### GENUNCHIERE

| Nu.   | specificație |    |
|-------|--------------|----|
| 37142 | komfort      | 20 |



### GENUNCHIERE

| Nu.   | specificație |    |
|-------|--------------|----|
| 37139 | neopren      | 10 |



### GENUNCHIERE

| Nu.   | specificație |   |
|-------|--------------|---|
| 37141 |              | 6 |





### MANUSA PIELE BOVINA

· Cu o căptușeală în mână



| Nu.   | specificație   |    |
|-------|----------------|----|
| 50518 | dimensiuni 11" | 12 |



### MANUSA PIELE BOVINA

· Cu o căptușeală în mână



| Nu.   | specificație     |    |
|-------|------------------|----|
| 50519 | dimensiuni 10,5" | 12 |



### MANUSI PIELE



| Nu.   | specificație     |    |
|-------|------------------|----|
| 50520 | dimensiuni 10,5" | 12 |



### MANUSI BUMBAC CU PUNCTE PVC

| Nu.   | specificație   |    |
|-------|----------------|----|
| 50524 | dimensiuni 10" | 12 |



### MANUSI PVC CU INSERTIE BUMBAC



| Nu.   | specificație                   |    |
|-------|--------------------------------|----|
| 50525 | dimensiuni 10" - lungime 35 cm | 12 |



### MANUSI POLIESTER CU PUNCTE PVC

· PVC pontokkal

| Nu.   | specificație   |    |
|-------|----------------|----|
| 50526 | dimensiuni 10" | 12 |



### MANUSI BUMBAC CU INVELIS LATEX



| Nu.   | specificație   |    |
|-------|----------------|----|
| 50522 | dimensiuni 10" | 12 |



### MANUSI NYLON CU INVELIS NITRIL

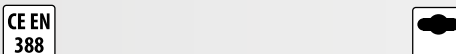

| Nu.   | specificație   |    |
|-------|----------------|----|
| 50533 | dimensiuni 10" | 12 |



### MANUSI NYLON CU INVELIS SPUMA LATEX

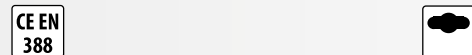

| Nu.   | specificație   |    |
|-------|----------------|----|
| 50535 | dimensiuni 8"  | 12 |
| 50536 | dimensiuni 9"  | 12 |
| 50537 | dimensiuni 10" | 12 |



### MANUSI NYLON CU INVELIS SPUMA NITRIL

· PVC pontokkal



| Nu.   | specificație   |    |
|-------|----------------|----|
| 50539 | dimensiuni 10" | 12 |



### MANUSA LATEX

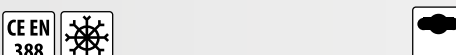

| Nu.   | specificație   |    |
|-------|----------------|----|
| 50529 | dimensiuni 10" | 12 |



### MANUSI



| Nu.   | specificație  |    |
|-------|---------------|----|
| 50557 | dimensiuni 7" | 12 |
| 50558 | dimensiuni 8" | 12 |
| 50549 | dimensiuni 9" | 12 |



### MANUSI BUMBAC CU PUNCTE PVC

· PVC pontokkal

| Nu.   | specificație  |    |
|-------|---------------|----|
| 50531 | dimensiuni 9" | 12 |



### MANUSI PIELE CAPRA CU INSERTIE NYLON



| Nu.   | specificație   |    |
|-------|----------------|----|
| 50541 | dimensiuni 9"  | 12 |
| 50542 | dimensiuni 10" | 12 |



### MANUSI PIELE PORC CU INSERTIE NYLON



| Nu.   | specificație   |    |
|-------|----------------|----|
| 50544 | dimensiuni 10" | 12 |



### MANUSI NYLON CU INVELIS POLIURETAN



| Nu.   | specificație   |    |
|-------|----------------|----|
| 50527 | dimensiuni 10" | 12 |



### MANUSI PIELE PENTRU SUDURA



| Nu.   | specificație   |    |
|-------|----------------|----|
| 50540 | dimensiuni 11" | 12 |



### MANUSI VINYL UNICA FOLOSINTA

· limpede, fără pudră



| Nu.   | specificație  |     |
|-------|---------------|-----|
| 50532 | dimensiuni 9" | 100 |



### MASCA PRAF



| Nu.   | specificație    |    |
|-------|-----------------|----|
| 50500 | FFP2 fara valva | 30 |



### MASCA PRAF



| Nu.   | specificație |    |
|-------|--------------|----|
| 50503 | FFP2 cu val  | 20 |



### COMBINEZON DE PROTECȚIE CU GLUGĂ

| Nu.   | specificație   |   |
|-------|----------------|---|
| 50585 | dimensiuni M   | 1 |
| 50586 | dimensiuni L   | 1 |
| 50587 | dimensiuni XL  | 1 |
| 50588 | dimensiuni XXL | 1 |

### SORT PENTRU SUDURĂ



| Nu.   | specificație |   |
|-------|--------------|---|
| 50555 | piele        | 1 |





**FESTO**

GEANTĂ PENTRU UNELTE CU MÂNER METALIC

| Nu.   | înălțime | lungime | adâncime |   |
|-------|----------|---------|----------|---|
| 37331 | 280 mm   | 490 mm  | 230 mm   | 2 |



**FESTO**

GEANTA SCULE

| Nu.   | lățime | înălțime | adâncime |   |
|-------|--------|----------|----------|---|
| 37332 | 480 mm | 290 mm   | 250 mm   | 1 |

**FESTO**

GEANTA SCULE

| Nu.   | lățime | înălțime | adâncime |   |
|-------|--------|----------|----------|---|
| 37330 | 610 mm | 400 mm   | 270 mm   | 5 |



**FESTO**

BUZUNARE RANFORSAȚE

Buzunare armate

| Nu.   | specificație |    |
|-------|--------------|----|
| 37325 |              | 10 |



**FESTO**

BUZUNARE RANFORSAȚE

Buzunare armate

| Nu.   | specificație |    |
|-------|--------------|----|
| 37326 |              | 12 |



**FESTO**

CENTURA NYLON

| Nu.   | specificație |    |
|-------|--------------|----|
| 37328 | 145 cm       | 20 |



**FESTA**  
CENTURA

· 14 buzunare + ochi

| Nu.   | lungime | lățime |   |
|-------|---------|--------|---|
| 37311 | 120 cm  | 6 cm   | 1 |



**FESTA**  
CENTURA NYLON

| Nu.   | lungime | lățime |   |
|-------|---------|--------|---|
| 37310 | 120 cm  | 6 cm   | 1 |



**FESTA**  
SUPPORT

· 8 buzunare

| Nu.   | lățime | înălțime |   |
|-------|--------|----------|---|
| 37320 | 300 mm | 250 mm   | 1 |



**FESTA**  
SUPPORT

· 4 buzunare

| Nu.   | lățime | înălțime |   |
|-------|--------|----------|---|
| 37321 | 350 mm | 300 mm   | 1 |



**FESTA**  
JACHETA DE LUCRU

| Nu.   | specificație |    |
|-------|--------------|----|
| 37350 |              | 20 |



**FESTA**  
CENTURA PENTRU UNELTE

| Nu.   | specificație |    |
|-------|--------------|----|
| 37302 | 6 buzunare   | 50 |
| 37303 | 11 buzunare  | 25 |



**FESTA**  
CENTURA PENTRU UNELTE

| Nu.   | specificație |    |
|-------|--------------|----|
| 37300 | 6 buzunare   | 50 |
| 37301 | 11 buzunare  | 25 |



**FESTA**



GEANTĂ DE PIELE PROFİ



| Nu.   | înălțime | lungime | adâncime |  |
|-------|----------|---------|----------|---|
| 37342 | 270 mm   | 430 mm  | 180 mm   | 1   |



GEANTĂ PROFİ PENTRU ELECTRICIENI



| Nu.   | înălțime | lungime | adâncime |  |
|-------|----------|---------|----------|---|
| 37341 | 260 mm   | 430 mm  | 200 mm   | 1   |



GEANTĂ DE PIELE CU FUND ÎNTĂRIT



| Nu.   | înălțime | lungime | adâncime |  |
|-------|----------|---------|----------|---|
| 37340 | 240 mm   | 430 mm  | 150 mm   | 1   |



GEANTĂ DE PIELE PROFİ



GEANTĂ DE PIELE CU FUND ÎNTĂRIT

| Nu.   | înălțime | lungime | adâncime |  |
|-------|----------|---------|----------|---|
| 37343 | 240 mm   | 430 mm  | 150 mm   | 1   |



GEANTĂ PROFİ PENTRU ELECTRICIENI

| Nu.   | înălțime | lungime | adâncime |  |
|-------|----------|---------|----------|---|
| 37345 | 270 mm   | 430 mm  | 180 mm   | 1   |

AGATATORI



| Nu.   | specificație |  |
|-------|--------------|---|
| 37308 |              | 20  |



AGATATORI



| Nu.   | specificație |  |
|-------|--------------|---|
| 37309 |              | 20  |



**FESTA****BUTUC YALA LUNG**

| Nu.   | specificație  |    |
|-------|---------------|----|
| 23001 | 65 mm · 175 g | 10 |

**BUTUC YALA LUNG NICHEL ACOPERIT**

| Nu.   | specificație |    |
|-------|--------------|----|
| 23000 | 65 mm · 75 g | 15 |

**FESTA****LACAT**

| Nu.   | specificație |    |
|-------|--------------|----|
| 23261 | 25 mm        | 6  |
| 23262 | 32 mm        | 12 |
| 23263 | 38 mm        | 6  |
| 23264 | 45 mm        | 6  |
| 23265 | 52 mm        | 12 |
| 23266 | 63 mm        | 6  |

**FESTA****LACAT RANFORSAT**

| Nu.   | specificație |    |
|-------|--------------|----|
| 23125 | 25 mm        | 12 |
| 23130 | 30 mm        | 12 |
| 23135 | 35 mm        | 12 |
| 23140 | 40 mm        | 12 |
| 23150 | 50 mm        | 12 |
| 23160 | 60 mm        | 12 |

**FESTA****LACAT DE ALAMA, ACOPERIT CU PLASTIC**

| Nu.   | specificație |    |
|-------|--------------|----|
| 23310 | 30 mm        | 10 |
| 23311 | 40 mm        | 10 |
| 23312 | 50 mm        | 6  |

**FESTA****LACAT LUNG**

| Nu.   | specificație |    |
|-------|--------------|----|
| 23211 | 25 mm        | 12 |
| 23212 | 32 mm        | 12 |
| 23213 | 38 mm        | 6  |
| 23214 | 45 mm        | 6  |
| 23215 | 52 mm        | 6  |

**FESTA****LACAT**

| Nu.   | specificație |    |
|-------|--------------|----|
| 23274 | 60 mm        | 6  |
| 23275 | 70 mm        | 12 |

**LACAT FIER**

| Nu.   | specificație |   |
|-------|--------------|---|
| 23220 | 25 mm        | 6 |
| 23225 | 30 mm        | 6 |
| 23232 | 32 mm        | 6 |
| 23240 | 40 mm        | 6 |
| 23250 | 50 mm        | 6 |
| 23260 | 60 mm        | 6 |

**LACAT**

| Nu.   | specificație |    |
|-------|--------------|----|
| 23020 | 20 mm        | 12 |
| 23025 | 25 mm        | 12 |
| 23030 | 30 mm        | 12 |
| 23035 | 35 mm        | 12 |
| 23040 | 40 mm        | 12 |
| 23050 | 50 mm        | 12 |
| 23060 | 60 mm        | 12 |





LACAT

LACAT LUNG



| Nu.   | specificatie |    |
|-------|--------------|----|
| 23070 | 40 mm        | 12 |



LACAT



| Nu.   | specificatie |   |
|-------|--------------|---|
| 23010 | 50 mm        | 6 |



| Nu.   | specificatie |   |
|-------|--------------|---|
| 23005 | 40 mm        | 6 |
| 23006 | 50 mm        | 6 |



FESTA

LACAT BICICLETA



| Nu.   | specificatie     |   |
|-------|------------------|---|
| 23288 | 120 cm x Ø 10 mm | 1 |



FESTA

LACAT BICICLETA



| Nu.   | specificatie    |   |
|-------|-----------------|---|
| 23287 | 65 cm x Ø 10 mm | 1 |



FESTA

LACAT BICICLETA



| Nu.   | specificatie    |   |
|-------|-----------------|---|
| 23290 | 120 cm x Ø 8 mm | 1 |
| 23291 | 150 cm x Ø 8 mm | 1 |
| 23292 | 180 cm x Ø 8 mm | 1 |

LACAT BICICLETA



| Nu.   | specificatie   |    |
|-------|----------------|----|
| 23282 | 55 cm x Ø 8 mm | 50 |
| 23284 | 65 cm x Ø 8 mm | 50 |



LACAT CIFRU



| Nu.   | specificatie |    |
|-------|--------------|----|
| 23281 |              | 20 |





**FESTA****SEIF  
CU ÎNCUIETOARE ELECTRONICĂ**

- Tip blocare: electronică, mecanică
- Cheie de securitate
- Dimensiuni 350x250x250mm
- Greutate 10 kg



| Nu.   | specificație |
|-------|--------------|
| 23270 |              |

1

**FESTA****BRELOCURI TIP ETICHETA**

100x



| Nu.   | specificație |
|-------|--------------|
| 23391 | 50           |

50

**BRELOCURI TIP ETICHETA**

100x



| Nu.   | specificație |
|-------|--------------|
| 23390 | 1            |

1

**CASETA PENTRU BANI**

| Nu.   | width  | deep  | height |
|-------|--------|-------|--------|
| 70120 | 125 mm | 95 mm | 60 mm  |

1

**CASETA PENTRU BANI**

| Nu.   | width  | deep   | height |
|-------|--------|--------|--------|
| 70121 | 152 mm | 118 mm | 80 mm  |

36

**CASETA PENTRU BANI**

| Nu.   | width  | deep   | height |
|-------|--------|--------|--------|
| 70122 | 200 mm | 160 mm | 90 mm  |

20

**CASETA PENTRU BANI**

| Nu.   | width  | deep   | height |
|-------|--------|--------|--------|
| 70123 | 250 mm | 180 mm | 90 mm  |

16

**ZĂVOR CU ARTICULAȚIE**

| Nu.   | specificație | specificație |
|-------|--------------|--------------|
| 51514 | 100 mm       | 25           |
| 51515 | 120 mm       | 25           |
| 51516 | 140 mm       | 25           |
| 51517 | 160 mm       | 25           |

**BOLȚ ÎNCHIDERE**

| Nu.   | specificație | specificație |
|-------|--------------|--------------|
| 51510 | 100 mm       | 12           |
| 51511 | 120 mm       | 12           |
| 51512 | 140 mm       | 12           |
| 51513 | 160 mm       | 12           |

**CUTIE**

| Nu.   | specificație                        | specificație |
|-------|-------------------------------------|--------------|
| 70140 | 250 x 180 x 80 mm - pentru 48 taste | 12           |
| 70141 | 300 x 230 x 90 mm - pentru 90 taste | 8            |

8



CASETA PENTRU BANI



| Nu.   | width  | deep   | height |    |
|-------|--------|--------|--------|----|
| 70124 | 300 mm | 240 mm | 90 mm  | 10 |



CASETA PENTRU BANI



| Nu.   | width  | deep   | height |   |
|-------|--------|--------|--------|---|
| 70125 | 370 mm | 280 mm | 90 mm  | 8 |



CUTIE POSTALA



| Nu.   | color | width  | height | deep   |   |
|-------|-------|--------|--------|--------|---|
| 70101 | alb   | 290 mm | 360 mm | 105 mm | 5 |
| 70100 | maro  | 290 mm | 360 mm | 105 mm | 5 |



CUTIE POSTALA



| Nu.   | color | width  | height | deep  |    |
|-------|-------|--------|--------|-------|----|
| 70102 | alb   | 310 mm | 260 mm | 90 mm | 10 |
| 70103 | maro  | 310 mm | 260 mm | 90 mm | 10 |



CUTIE POSTALA



| Nu.   | color | width  | height | deep  |   |
|-------|-------|--------|--------|-------|---|
| 70105 | maro  | 310 mm | 360 mm | 90 mm | 5 |



CUTIE POSTALA



| Nu.   | color | width  | deep   | height |   |
|-------|-------|--------|--------|--------|---|
| 70108 | alb   | 370 mm | 134 mm | 364 mm | 5 |



CUTIE POSTALA



| Nu.   | width | deep   | height |        |   |
|-------|-------|--------|--------|--------|---|
| 70107 | inox  | 360 mm | 100 mm | 520 mm | 6 |



CUTIE POSTALA



| Nu.   | width | deep   | height |        |   |
|-------|-------|--------|--------|--------|---|
| 70106 | inox  | 360 mm | 100 mm | 360 mm | 5 |



CUTIE POSTALA



| Nu.   | width | deep   | height |        |   |
|-------|-------|--------|--------|--------|---|
| 70109 | inox  | 310 mm | 90 mm  | 260 mm | 6 |



CUTIE POSTALA



| Nu.   | width | deep   | height |        |   |
|-------|-------|--------|--------|--------|---|
| 70110 | inox  | 310 mm | 90 mm  | 360 mm | 6 |

## CANTAR DE BUZUNAR

| Nu.   | max.  |    |  |
|-------|-------|----|--|
| 24260 | 50 kg | 10 |  |



## CANTAR DE BUZUNAR

| Nu.   | max.    |    |  |
|-------|---------|----|--|
| 24212 | 12,5 kg | 12 |  |
| 24225 | 25 kg   | 6  |  |
| 24250 | 50 kg   | 6  |  |
| 24255 | 100 kg  | 6  |  |
| 24258 | 150 kg  | 6  |  |



## PENSETE CU LUMINA LED

| Nu.   | specificație |   |  |
|-------|--------------|---|--|
| 50005 | 95 mm        | 8 |  |



## PENSETE

| Nu.   | specificație |   |  |
|-------|--------------|---|--|
| 50004 |              | 1 |  |



## CAPCANA SOARECI LEMN

| Nu.   | specificație       |   |  |
|-------|--------------------|---|--|
| 70221 | 90 x 45 mm de lemn | 1 |  |



## CAPCANA SOARECI LEMN

| Nu.   | specificație       |    |  |
|-------|--------------------|----|--|
| 70220 | 97 x 47 mm plastic | 48 |  |



## FURTUN ELASTIC PENTRU CANAL

| Nu.   | length | Ø    |   |
|-------|--------|------|---|
| 50014 | 6 m    | 6 mm | 6 |



## FURTUN ELASTIC PENTRU CANAL

| Nu.   | length |    |  |
|-------|--------|----|--|
| 50010 | 3 m    | 10 |  |
| 50011 | 5 m    | 5  |  |
| 50012 | 10 m   | 3  |  |
| 50013 | 15 m   | 4  |  |



## FURTUN ELASTIC PENTRU CANAL

| Nu.   | length | Ø    |    |
|-------|--------|------|----|
| 50009 | 3 m    | 5 mm | 40 |



## POMPA ABSORBȚIE

| Nu.   | length | Ø     |    |
|-------|--------|-------|----|
| 50015 | 385 mm | 65 mm | 30 |



## CABLU GHIDARE (SARPE)

| Nu.   | length | Ø    |    |
|-------|--------|------|----|
| 51181 | 8 m    | 5 mm | 25 |
| 51182 | 10 m   | 5 mm | 25 |





INSTRUMENTE  
DE CONSTRUIRE

242 - 307





# FESTA

## FESTA

GLETIERA INOX CU  
MANER CAUCIUC  
280 X 130 MM



· maner de cauciuc



| Nu.   | specificatie |    |
|-------|--------------|----|
| 31140 | drept        | 10 |

## FESTA

GLETIERA INOX CU  
MANER CAUCIUC  
280 X 130 MM



· maner de cauciuc



| Nu.   | specificatie        |    |
|-------|---------------------|----|
| 31148 | drept s oblymi rohy | 10 |

## FESTA

GLETIERA CU  
MANER CAUCIUC  
280 X 130 MM



· maner de cauciuc



| Nu.   | specificatie |    |
|-------|--------------|----|
| 31146 | Ø 16         | 10 |

## FESTA

GLETIERA INOX CU  
MANER CAUCIUC  
280 X 130 MM



· maner de cauciuc



| Nu.   | specificatie |    |
|-------|--------------|----|
| 31141 | e 4          | 10 |
| 31142 | e 6          | 10 |
| 31143 | e 8          | 10 |

| Nu.   | specificatie |    |
|-------|--------------|----|
| 31144 | e 10         | 10 |
| 31145 | e 12         | 10 |

## FESTA

GLETIERA  
INOX  
280 X 130 MM



| Nu.   | specificatie |    |
|-------|--------------|----|
| 31101 | e 4          | 10 |
| 31111 | e 6          | 10 |
| 31121 | e 8          | 10 |

| Nu.   | specificatie |    |
|-------|--------------|----|
| 31131 | e 10         | 10 |
| 31132 | e 12         | 10 |

## FESTA

GLETIERA  
INOX  
280 X 130 MM



| Nu.   | specificatie |    |
|-------|--------------|----|
| 31091 | drept        | 10 |

**FESTA**

GLETIERA  
INOX  
280 X 130 MM



| Nu.   | specificație |    |
|-------|--------------|----|
| 31011 | drept        | 10 |

**FESTA**

GLETIERA  
INOX  
280 X 130 MM



| Nu.   | specificație |    | Nu.   | specificație |    |
|-------|--------------|----|-------|--------------|----|
| 31021 | e 4          | 10 | 31051 | e 10         | 10 |
| 31031 | e 6          | 10 | 31053 | e 12         | 10 |
| 31041 | e 8          | 10 |       |              |    |

GLETIERA  
INOX  
270 X 125 MM



| Nu.   | specificație |    |
|-------|--------------|----|
| 31005 | drept        | 25 |

GLETIERA  
INOX  
270 X 125 MM



| Nu.   | specificație |    | Nu.   | specificație |    |
|-------|--------------|----|-------|--------------|----|
| 31006 | e 4          | 24 | 31008 | e 8          | 24 |
| 31007 | e 6          | 24 | 31009 | e 10         | 24 |

**FESTA**

GLETIERA  
INOX  
360 X 130 MM



| Nu.   | specificație |    |
|-------|--------------|----|
| 31151 | drept        | 10 |

**FESTA**

GLADILICA  
ROST FREI  
360 X 130 MM



| Nu.   | specificație |    | Nu. | specificație |  |
|-------|--------------|----|-----|--------------|--|
| 31150 | drept        | 10 |     |              |  |

**FESTA**

GLETIERA  
INOX  
480 X 130 MM



| Nu.   | specificație |    |
|-------|--------------|----|
| 31082 | drept        | 10 |

**FESTA**

GLETIERA  
INOX  
680 X 130 MM



| Nu.   | specificație |    |
|-------|--------------|----|
| 31155 | drept        | 10 |

**FESTA**

GLETIERA  
INOX  
500 X 130 MM



| Nu.   | specificație |    |
|-------|--------------|----|
| 31052 | e 4          | 10 |
| 31061 | e 6          | 10 |
| 31062 | e 8          | 10 |
| 31071 | e 10         | 10 |
| 31072 | e 12         | 10 |

**FESTA**

GLETIERA  
INOX  
500 X 130 MM



| Nu.   | specificație |    |
|-------|--------------|----|
| 31081 | drept        | 10 |



**FESTA**

## MISTRIE INOX

INOX · maner de cauciuc

| Nu.   | specificație |  |
|-------|--------------|---|
| 31232 | 120 mm       | 10  |
| 31233 | 140 mm       | 10  |

**FESTA**

## MISTRIE INOX

INOX

| Nu.   | specificație |  |
|-------|--------------|---|
| 31220 | 120 x 80 mm  | 10  |
| 31221 | 140 x 80 mm  | 10  |

**FESTA**

## MISTRIE INOX

INOX · maner de cauciuc

| Nu.   | specificație |  |
|-------|--------------|---|
| 31334 | 160 x 100 mm | 10  |

**FESTA**

## MISTRIE INOX

INOX

| Nu.   | specificație |  |
|-------|--------------|---|
| 31343 | 160 x 100 mm | 10  |

**FESTA**

## MISTRIE PENTRU CHIT

INOX · maner de cauciuc

| Nu.   | specificație |  |
|-------|--------------|---|
| 31360 | 40 mm        | 10  |
| 31380 | 60 mm        | 10  |
| 31390 | 80 mm        | 10  |

**FESTA**

## MISTRIE PENTRU CHIT

INOX

| Nu.   | specificație |  |
|-------|--------------|---|
| 31362 | 40 mm        | 10  |
| 31382 | 60 mm        | 10  |

**FESTA**

## MISTRIE LIMBA DE PISICA

INOX · maner de cauciuc

| Nu.   | specificație |  |
|-------|--------------|---|
| 31330 | 140 x 50 mm  | 10  |
| 31340 | 160 x 60 mm  | 10  |

**FESTA**

## MISTRIE LIMBA DE PISICA

INOX

| Nu.   | specificație |  |
|-------|--------------|---|
| 31332 | 140 x 50 mm  | 10  |
| 31341 | 160 x 60 mm  | 10  |

**FESTA**

## MISTRIE PENTRU COLT INTERIOR

INOX · maner de cauciuc

| Nu.   | specificație    |  |
|-------|-----------------|---|
| 31280 | 80 x 60 x 60 mm | 10  |

**FESTA**

## MISTRIE PENTRU COLT INTERIOR

INOX

| Nu.   | specificație    |  |
|-------|-----------------|---|
| 31281 | 80 x 60 x 60 mm | 10  |

**FESTA**

## MISTRIE PENTRU COLT EXTERIOR

INOX · maner de cauciuc

| Nu.   | specificație    |  |
|-------|-----------------|---|
| 31270 | 80 x 60 x 60 mm | 10  |

**FESTA**

## MISTRIE PENTRU COLT EXTERIOR

INOX

| Nu.   | specificație    |  |
|-------|-----------------|---|
| 31271 | 80 x 60 x 60 mm | 10  |





**FESTA**

**MISTRIE PENTRU CHIT**

INOX · maner de cauciuc

| Nu.   | specificație |  |
|-------|--------------|---|
| 31320 | 140 x 75 mm  | 10  |



**FESTA**

**MISTRIE PENTRU CHIT**

INOX

| Nu.   | specificație |  |
|-------|--------------|---|
| 31322 | 140 x 75 mm  | 10  |



**FESTA**

**MISTRIE INOX**

INOX

| Nu.   | specificație |  |
|-------|--------------|---|
| 31218 | 180 mm e 6   | 12  |



**FESTA**

**SPACLU INOX**

· maner de cauciuc

INOX

| Nu.   | specificație |  |
|-------|--------------|---|
| 31510 | 40 mm        | 10  |
| 31511 | 60 mm        | 10  |
| 31512 | 80 mm        | 10  |



**FESTA**

**RAZUIITOR INOX, MANER CAUCIUC**

· maner de cauciuc  
· lama armata

INOX

| Nu.   | specificație |  |
|-------|--------------|---|
| 32173 | 75 mm        | 10  |



**FESTA**

**RAZUIITOR, MARGINE ASCUTITA**

· maner 52010  
· lama armata

INOX

| Nu.   | specificație |  |
|-------|--------------|---|
| 32170 | 100 mm       | 12  |



**FESTA**

**SPACLURI + BIT**

· maner de cauciuc

INOX

| Nu.   | specificație |  |
|-------|--------------|---|
| 31455 | 150 mm       | 12  |
| 31456 | 200 mm       | 12  |

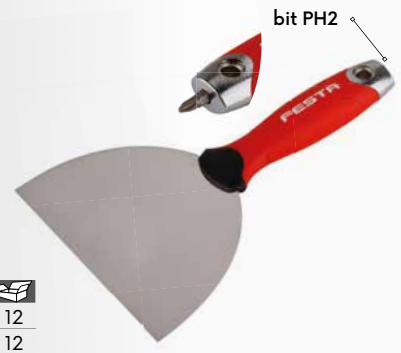

**FESTA**

**SPACLU INOX**

INOX

| Nu.   | specificație |  |
|-------|--------------|---|
| 31517 |              | 10  |



**FESTA**

**SPACLU RIGIPS**

· maner de cauciuc

INOX

| Nu.   | specificație |  |
|-------|--------------|---|
| 31505 | 200 mm       | 5   |
| 31506 | 250 mm       | 5   |
| 31507 | 300 mm       | 5   |



**FESTA****RAZVITOR MANER LEMN LUNG**

· lama armata

**INOX**

| Nu.   | width  | lungime |   |
|-------|--------|---------|---|
| 32174 | 100 mm | 500 mm  | 1 |

**FESTA****SPACLURI****INOX**

| R.s.  | leirás |    |
|-------|--------|----|
| 31461 | 40 mm  | 12 |
| 31471 | 60 mm  | 12 |
| 31481 | 80 mm  | 12 |
| 31491 | 100 mm | 12 |
| 31467 | 120 mm | 12 |
| 31468 | 140 mm | 12 |

**FESTA****SPACLU INOX****INOX**

| Nu.   | specificatie |    |
|-------|--------------|----|
| 31498 | 150 mm       | 12 |
| 31499 | 200 mm       | 12 |
| 31500 | 100 mm       | 12 |

**SPACLU****INOX**

MADE IN EU

| Nu.   | specificatie |    |
|-------|--------------|----|
| 31493 | 40 mm        | 20 |
| 31494 | 60 mm        | 20 |
| 31495 | 80 mm        | 20 |
| 31496 | 100 mm       | 20 |

**SPACLURI OTEL**

| R.s.  | leirás |    |
|-------|--------|----|
| 32176 | 30 mm  | 12 |
| 32186 | 40 mm  | 12 |
| 32196 | 50 mm  | 12 |
| 32206 | 60 mm  | 12 |
| 32216 | 80 mm  | 12 |
| 32226 | 100 mm | 12 |
| 32234 | 125 mm | 12 |

**SET SPACLURI****3x**

| Nu.   | specificatie  |    |
|-------|---------------|----|
| 32240 | 30, 50, 80 mm | 10 |

**FESTA****SPACLURI OTEL**

| Nu.   | specificatie |    | Nu.   | specificatie |    |
|-------|--------------|----|-------|--------------|----|
| 32161 | 30 mm        | 10 | 32171 | 90 mm        | 10 |
| 32162 | 40 mm        | 10 | 32166 | 100 mm       | 10 |
| 32163 | 50 mm        | 10 | 32172 | 110 mm       | 10 |
| 32164 | 60 mm        | 10 | 32167 | 120 mm       | 10 |
| 32169 | 70 mm        | 10 | 32168 | 140 mm       | 10 |
| 32165 | 80 mm        | 10 |       |              |    |

**ROLA PENTRU APLICAREA MISTRIEI**

- maner 180 mm - 52630
- maner 250 mm - 52625
- mâner lung 52010, 52011, 52012, 52020, 52030

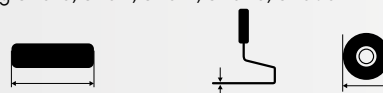

| Nu.   | Specificatie |        |         |    |
|-------|--------------|--------|---------|----|
| 52611 | 250 mm       | Ø 8 mm | Ø 48 mm | 50 |
| 52612 | 180 mm       | Ø 8 mm | Ø 48 mm | 10 |

**FESTA**

SPATULE  
PENTRU ETANȘAREA  
ÎNTREGII ZONE

**INOX**

| R.s.  | leirás |  |
|-------|--------|---|
| 31555 | 35 cm  | 1   |
| 31556 | 45 cm  | 1   |
| 31557 | 60 cm  | 1   |
| 31558 | 80 cm  | 1   |
| 31559 | 100 cm | 1   |



**FESTA**

SUPPORT SPATULA  
PENTRU ETANȘAREA  
PE TOATĂ SUPRAFAȚA

- pentru 31555 - 31559
- mâner 52010, 52011, 52012, 52020, 52030

| Nu.   | Specificație |  |
|-------|--------------|---|
| 31610 |              | 1   |

**FESTA**

MANER TELESCOPIC

- filet pentru 31610, 34203

| Nu.   | Specificație |  |
|-------|--------------|---|
| 52011 | 88 - 140 cm  | 1   |

SPATULE DIN OTEL  
INOXIDABIL  
CU ARMARE

**INOX**

MADE IN  
**EU**

| Nu.   | specificație |  |
|-------|--------------|---|
| 31520 | 400 mm       | 1   |
| 31521 | 500 mm       |   |
| 31522 | 600 mm       |   |



mâner 61254



ACCESORII SPATULA DE ARMARE

MADE IN  
**EU**

| Nu.   | specificație    |  |
|-------|-----------------|---|
| 31523 | titular ALU     | 1   |
| 31524 | titular plastic | 1   |

SPACLU  
PENTRU  
FATADE

**INOX**

| Nu.   | specificație |  |
|-------|--------------|---|
| 31552 | 400 mm       | 10  |
| 31553 | 600 mm       | 10  |



SPACLU  
PENTRU  
FATADE

**INOX**

MADE IN  
**EU**

| Nu.   | specificație  |  |
|-------|---------------|---|
| 31541 | 250 mm        | 1   |
| 31551 | 250 mm ingust | 1   |



## GLETIERA ASCUTITA

| Nu.   | specificatie |  |
|-------|--------------|---|
| 32062 | 280 x 160 mm | 10  |
| 32060 | 500 x 140 mm | 5   |

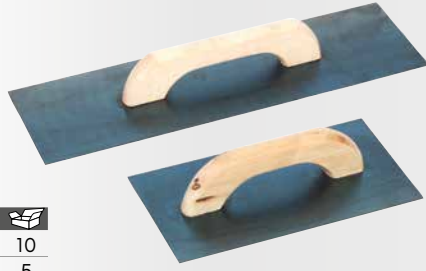

## GLETIERA ASCUTITA

| Nu.   | specificatie |  |
|-------|--------------|---|
| 32064 | 500 x 90 mm  | 5   |
| 32066 | 550 x 140 mm | 5   |



## MISTRIE OTEL

| Nu.   | specificatie |  |
|-------|--------------|---|
| 32015 | 160 x 130 mm | 10  |
| 32014 | 180 x 130 mm | 10  |
| 32016 | 200 x 140 mm | 10  |



## MISTRIE OTEL

| Nu.   | specificatie |  |
|-------|--------------|---|
| 32001 | 160 x 110 mm | 10  |
| 32002 | 160 x 130 mm | 10  |
| 32003 | 180 x 130 mm | 10  |
| 32013 | 200 x 140 mm | 10  |



## MISTRIE OTEL ROTUNJIT

| Nu.   | specificatie |  |
|-------|--------------|---|
| 32018 | 160 x 110 mm | 10  |



## MISTRIE

| Nu.   | specificatie |  |
|-------|--------------|---|
| 32024 | 140 x 80 mm  | 12  |



## MISTRIE OTEL

| Nu.   | specificatie |  |
|-------|--------------|---|
| 32020 | 140 x 65 mm  | 12  |
| 32021 | 140 x 40 mm  | 12  |



## MISTRIE

| Nu.   | specificatie |  |
|-------|--------------|---|
| 32026 | 140 x 85 mm  | 12  |



## FESTA CANCIOC INOXIDABIL

| <b>INOX</b> |              |   |
|-------------|--------------|---|
| Nu.         | specificatie |  |
| 32285       | Ø 180 mm     | 1   |



## FESTA CANCIOC ZINCAT

| <b>Zn</b> |              |   |
|-----------|--------------|---|
| Nu.       | specificatie |  |
| 32265     | Ø 180 mm     | 10  |





## FESTA CANCIOC

| Nu.   | specificatie |  |
|-------|--------------|---|
| 32273 | Ø 160 mm     | 10  |
| 32283 | Ø 180 mm     | 10  |
| 32293 | Ø 215 mm     | 10  |



## CANCIOC PLASTIC

|  |              |   |
|---|--------------|---|
| Nu.   | specificatie |  |
| 32270   | Ø 160 mm     | 1   |



CANCIOC

· drșka 61215

| Nu.   | specificație |  |
|-------|--------------|---|
| 32302 | Ø 180 mm     | 1   |
| 32313 | Ø 215 mm     | 1   |
| 32301 | Ø 235 mm     | 1   |



CANCIOC

· maner 61200, 61201

| Nu.   | specificație |  |
|-------|--------------|---|
| 32268 | Ø 215 mm     | 1   |
| 32269 | Ø 235 mm     | 1   |
| 32296 | Ø 215 mm     | 1   |



SCULA PENTRU BETON

| Nu.   | specificație            |  |
|-------|-------------------------|---|
| 60100 | fără mâner 295 x 150 mm | 24  |
| 61169 | cu mâner 160 cm         | 3   |
| 61218 | maner 160 cm            | 5   |



CANCIOC

MOQ  
3

| Nu.   | specificație          |  |
|-------|-----------------------|---|
| 32295 | Ø 180 mm maner 160 cm | 3   |
| 32297 | Ø 215 mm maner 160 cm | 3   |
| 32298 | Ø 235 mm maner 160 cm | 3   |



DISPOZITIV PENTRU SCOBITURI

| Nu.   | specificație |  |
|-------|--------------|---|
| 32037 | 600 mm       | 1   |



VINCLU YTONG

| Nu.   | specificație       |  |
|-------|--------------------|---|
| 32038 | 270 x 270 x 270 mm | 1   |



MISTRIE DINTATA YTONG

| Nu.   | specificație |  |
|-------|--------------|---|
| 32089 | 150 mm       | 1   |



FESTA

DALTA LATA MANER PROTECTIE

| CrV   | Nu.    | specificație | lățime hrotu |  |
|-------|--------|--------------|--------------|---|
|       | 19406  | 300 mm       | 25 mm        | 5   |
| 19407 | 400 mm | 30 mm        | 5            |   |



FESTA

DALTA SPIT MANER PROTECTIE

| CrV   | Nu.    | specificație |  |
|-------|--------|--------------|---|
|       | 19408  | 250 mm       | 5   |
| 19409 | 350 mm | 5            |   |



FESTA

DALTA LATA MANER PROTECTIE

| CrV   | Nu.    | specificație | lățime hrotu |  |
|-------|--------|--------------|--------------|---|
|       | 19460  | 300 mm       | 25 mm        | 5   |
| 19470 | 400 mm | 30 mm        | 5            |   |



DALTA SPIT MANER PROTECTIE

| Nu.   | specificație |  |
|-------|--------------|---|
| 19400 | 250 mm       | 5   |
| 19403 | 350 mm       | 6   |



DALTA LATA MANER PROTECTIE

| Nu.   | specificație | lățime hrotu |  |
|-------|--------------|--------------|---|
| 19401 | 250 mm       | 19 mm        | 6   |
| 19404 | 350 mm       | 22 mm        | 6   |



DALTA LATA MANER PROTECTIE

| Nu.   | specificație | lățime hrotu |  |
|-------|--------------|--------------|---|
| 19402 | 250 mm       | 50 mm        | 2   |
| 19405 | 350 mm       | 50 mm        | 6   |





**FESTA**  
RAZUIOR  
ROSTURI

INOX

| Nu.   | specificatie |
|-------|--------------|
| 31519 | 75 mm        |



10



## RAZUIOR ROSTURI

INOX

| Nu.   | specificatie |
|-------|--------------|
| 31497 | 63 x 195 mm  |



12



**FESTA**  
CUTIT  
TAPET

INOX

| Nu.   | specificatie |
|-------|--------------|
| 31503 | 150 mm       |



12



## RAZUIOARE

MADE IN EU

| Nu.   | specificatie |
|-------|--------------|
| 31501 | 100 mm       |
| 31502 | rezerva      |



30

1



## SPACLU PENTRU GIPS

PLASTIC

| Nu.   | specificatie |
|-------|--------------|
| 34308 | 50 mm        |
| 34307 | 80 mm        |
| 34306 | 100 mm       |
| 34305 | 150 mm       |



20

12

10

12



## SUPPORT PENTRU SLEFUIT

| Nu.   | specificatie |
|-------|--------------|
| 34301 | 230 x 105 mm |
| 34304 | 235 x 80 mm  |



1

1



**FESTA**  
SUPPORT PENTRU SLEFUIT

| Nu.   | specificatie |
|-------|--------------|
| 34200 | 210 x 115 mm |
| 34201 | 240 x 105 mm |
| 34202 | 240 x 80 mm  |



30

50

50



## SUPPORT CU ARTICULATIE MOBILA

maner 52030

ALU

| Nu.   | specificatie          |
|-------|-----------------------|
| 34203 | 230 x 80 mm aluminium |
| 52030 | coada telescopica     |



1

12



PLASA  
ABRAZIVA  
10 BUC

10x

| Nu.   | specificatie          |
|-------|-----------------------|
| 34271 | 115 x 290 mm kem. 120 |
| 34272 | 115 x 290 mm kem. 100 |
| 34273 | 115 x 290 mm kem. 80  |
| 34274 | 93 x 290 mm kem. 120  |
| 34275 | 93 x 290 mm kem. 100  |
| 34276 | 93 x 290 mm kem. 80   |



PLASA  
ABRAZIVA  
3 BUC

3x

| Nu.   | specificatie          |
|-------|-----------------------|
| 34280 | 115 x 290 mm kem. 120 |
| 34281 | 115 x 290 mm kem. 100 |
| 34282 | 115 x 290 mm kem. 80  |
| 34283 | 93 x 290 mm kem. 120  |
| 34284 | 93 x 290 mm kem. 100  |
| 34285 | 93 x 290 mm kem. 80   |



20

20

20

20

20

20

20

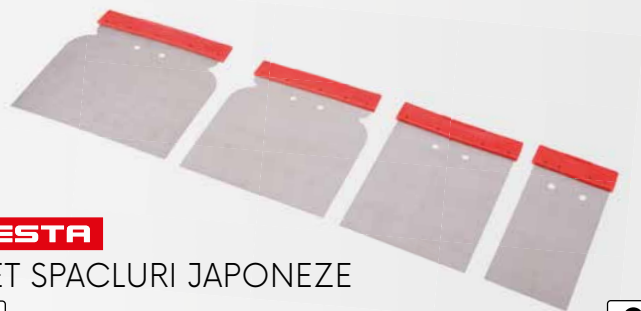

**FESTA**

SET SPACLURI JAPONEZE

4x

| Nu.   | specificatie             |    |
|-------|--------------------------|----|
| 31452 | inox 50, 80, 100, 120 mm | 10 |
| 31453 | otel 50, 80, 100, 120 mm | 10 |



**FESTA**

SET SPACLURI JAPONEZE

4x

| Nu.   | specificatie        |    |
|-------|---------------------|----|
| 31454 | 50, 80, 100, 120 mm | 12 |



MISTRIE DE OTEL

| Nu.   | specificatie   |   |
|-------|----------------|---|
| 31601 | 180 mm - Drept | 1 |
| 31602 | 180mm A1       | 1 |
| 31603 | 180mm A2       | 1 |
| 31641 | 180 mm - e4    | 1 |

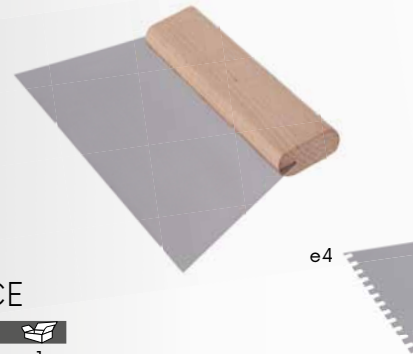

SPACLURI ELASTICE

| Nu.   | specificatie   |   |
|-------|----------------|---|
| 31651 | 250 mm - Drept | 1 |
| 31655 | 250 mm - e4    | 1 |



SPATULA DINTATA PLASTIC

| Nu.   | specificatie |     |
|-------|--------------|-----|
| 37101 | 125 x 85 mm  | 100 |
| 37111 | 170 x 115 mm | 100 |



SPATULA PLASTIC

| Nu.   | specificatie   |   |
|-------|----------------|---|
| 37051 | drept          | 1 |
| 37031 | zub - 4 x 6 mm | 1 |
| 37041 | zub - 6 x 6 mm | 1 |



MISTRIE

| Nu.   | specificatie |    |
|-------|--------------|----|
| 32022 | 140 x 80 mm  | 12 |
| 32023 | 125 x 40 mm  | 12 |

MISTRIE PENTRU IMBINARI

| Nu.   | specificatie |    |
|-------|--------------|----|
| 32040 | 10 mm        | 20 |
| 32041 | 12 mm        | 20 |
| 32042 | 15 mm        | 20 |
| 32043 | 18 mm        | 20 |
| 32044 | 20 mm        | 20 |



MISTRIE PENTRU IMBINARI, DOUA CANTURI

| Nu.   | specificatie |    |
|-------|--------------|----|
| 32050 | 10   12 mm   | 50 |
| 32051 | 10   15 mm   | 50 |
| 32052 | 10   18 mm   | 50 |
| 32053 | 15   20 mm   | 50 |

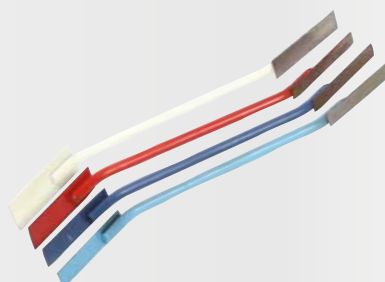

**FESTA**GLETIERA  
RAZUIITOR

· plop

MOQ  
2Nu. specificatie  
32317 450 x 95 mm

2

**FESTA**YTONG GLETIERA  
RAZUIITOR  
DINTE FIN

· plop

MOQ  
2Nu. specificatie  
32312 450 x 95 mm

2

**FESTA**GLETIERA  
YTONG

· plop

MOQ  
2Nu. specificatie  
32337 260 x 95 mm

2

**FESTA**YTONG GLETIERA  
RAZUIITOR  
DINTE FIN

· plop

MOQ  
2Nu. specificatie  
32338 260 x 95 mm

2

**FESTA**

GLETIERA

· plop

MOQ  
2Nu. specificatie  
32327 230 x 145 mm

2

GLETIERA  
YTONGNu. Specificatie  
32332 450 x 95 mmMOQ  
2

2



GLETIERA

Nu. Specificatie  
32333 230 x 145 mmMOQ  
2

2

**FESTA**GLETIERA  
RAZUIITORNu. specificatie  
32314 400 x 180 mmMOQ  
2

2

**FESTA**GLETIERA  
RAZUIITORNu. specificatie  
32329 270 x 130 mmMOQ  
2

2

GLETIERA  
RAZUIITORNu. specificatie  
33168 380 x 160 mmMOQ  
2

2

**FESTA**GLETIERA  
RAZUIITOR  
CU LAMENu. specificatie  
32320 400 x 180 mmMOQ  
2

2





GLETIERA RAZUIITOR



MOQ 2

| Nu.   | specificație |   |
|-------|--------------|---|
| 32311 | 400 x 180 mm | 2 |

FESTA

SLEFUIITOR POLISTIREN PLASTIC



MOQ 2

| Nu.   | specificație                      |    |
|-------|-----------------------------------|----|
| 32324 | 270 x 130 mm P 16                 | 2  |
| 32323 | 270 x 130 mm P 16 Hartie abraziva | 10 |

GLETIERA RAZUIITOR PENTRU VATĂ DE PIATRĂ

Zn



MOQ 2

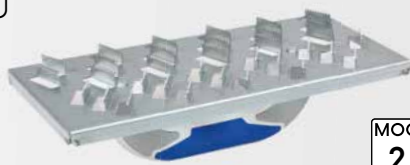

| Nu.   | specificație |    |
|-------|--------------|----|
| 32328 | 285 x 145 mm | 10 |

GLETIERA OTEL

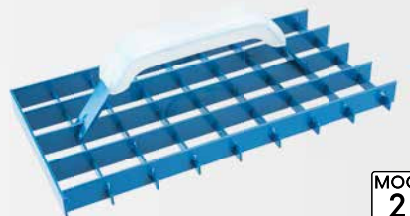

MOQ 2

| Nu.   | specificație |    |
|-------|--------------|----|
| 32316 | 280 x 150 mm | 20 |

GLETIERA

8 lame

ALU

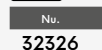

MOQ 2



| Nu.   | specificație |    |
|-------|--------------|----|
| 32326 | 450 x 90 mm  | 20 |

FESTA

GLETIERA PLASTIC



| Nu.   | specificație |    |
|-------|--------------|----|
| 34027 | 400 x 180 mm | 20 |

FESTA

SLEFUIITOR POLISTIREN



MOQ 2

| Nu.   | specificație                      |    |
|-------|-----------------------------------|----|
| 32318 | 400 x 180 mm                      | 2  |
| 32319 | 500 x 250 mm                      | 2  |
| 32321 | 400 x 180 mm P 16 Hartie abraziva | 10 |
| 32322 | 500 x 250 mm P 16 Hartie abraziva | 10 |

FESTA

GLETIERE PLASTIC CU ABRAZIV



MOQ 2

| Nu.   | specificație |   |
|-------|--------------|---|
| 32330 | 400 x 180 mm | 2 |
| 32331 | 270 x 130 mm | 2 |

FESTA

GLETIERA



MOQ 2



| Nu.   | specificație |   |
|-------|--------------|---|
| 32325 | 225 x 105 mm | 2 |

GLETIERA OTEL



MOQ 2

| Nu.   | specificație |   |
|-------|--------------|---|
| 32335 | 290 x 145 mm | 2 |

GLETIERA RAZUIITOR CU LAME

6 lame

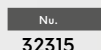

MOQ 2



| Nu.   | specificație |    |
|-------|--------------|----|
| 32315 | 270 x 90 mm  | 30 |

GLETIERA PLASTIC



| Nu.   | specificație |    |
|-------|--------------|----|
| 34028 | 400 x 180 mm | 20 |

**FESTA****GLETIERA ABS**

MADE IN EU

| Nu.   | specificatie               |    |
|-------|----------------------------|----|
| 34041 | 280 x 140 - 2 mm           | 10 |
| 34051 | 280 x 140 - 3 mm           | 10 |
| 34053 | 280 x 140 - 3 mm zubi - e6 | 10 |

**FESTA****GLETIERA**

| Č.p.  | specifikace  |    |
|-------|--------------|----|
| 30003 | 270 x 125 mm | 28 |
| 30004 | 235 x 115 mm | 35 |
| 30005 | 210 x 115 mm | 38 |
| 30007 | 210 x 60 mm  | 44 |

**FESTA****GLETIERA LEMN**

· lemn de tei



| Nu.   | specificatie |    |
|-------|--------------|----|
| 34005 | 400 x 145 mm | 40 |
| 34007 | 290 x 145 mm | 20 |

**GLETIERA LEMN**

· lemn de plop



| Nu.   | specificatie |    |
|-------|--------------|----|
| 34006 | 400 x 145 mm | 40 |

**GLETIERA POLIURETAN**

MADE IN EU

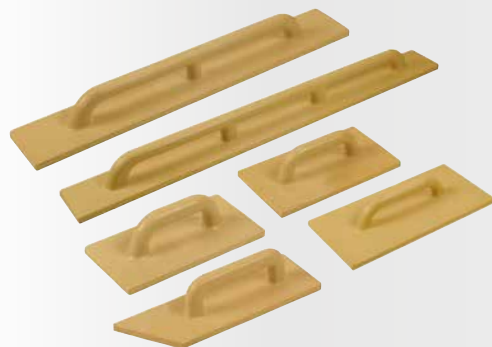

| Nu.   | specificatie          |    | Nu.   | specificatie  |    |
|-------|-----------------------|----|-------|---------------|----|
| 34122 | 120 x 240 mm          | 50 | 34154 | 220 x 420 mm  | 15 |
| 34132 | 140 x 280 mm          | 40 | 34155 | 240 x 480 mm  | 15 |
| 34142 | 180 x 320 mm          | 25 | 34156 | 280 x 500 mm  | 10 |
| 34152 | 200 x 360 mm          | 20 | 34157 | 330 x 330 mm  | 5  |
| 34121 | 80 x 260 mm<br>teșită | 50 | 34158 | 120 x 800 mm  | 5  |
| 34153 | 100 x 400 mm          | 30 | 34159 | 120 x 1000 mm | 5  |
|       |                       |    | 34160 | 120 x 1200 mm | 5  |

**GLETIERA STYROHART**

MADE IN EU

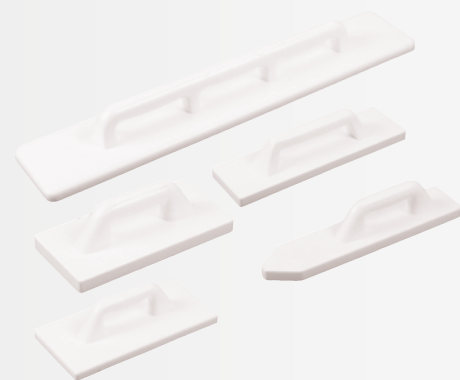

| Nu.   | specificatie       |    |
|-------|--------------------|----|
| 34101 | 80 x 350 mm teșită | 10 |
| 34061 | 130 x 270 mm       | 10 |
| 34111 | 170 x 320 mm       | 10 |
| 34071 | 130 x 450 mm       | 10 |
| 34081 | 140 x 750 mm       | 10 |
| 34091 | 140 x 900 mm       | 5  |

**GLETIERA POLIURETAN**

| Nu.   | specificatie |    |
|-------|--------------|----|
| 34115 | 140 x 280 mm | 36 |
| 34116 | 180 x 320 mm | 36 |
| 34117 | 200 x 360 mm | 24 |

**TAVA NIVELARE BETON**

MADE IN EU



| Nu.   | specificatie               |   |
|-------|----------------------------|---|
| 15889 | 980 x 380 mm maner Ø 32 mm | 1 |

**UNEALTA PENTRU INTINS**

| Nu.   | specificatie         |    |
|-------|----------------------|----|
| 15886 | 450 mm maner Ø 23 mm | 48 |
| 15887 | 600 mm maner Ø 23 mm | 48 |
| 15888 | 750 mm maner Ø 23 mm | 32 |

**UNEALTA PENTRU INTINS**

MADE IN EU

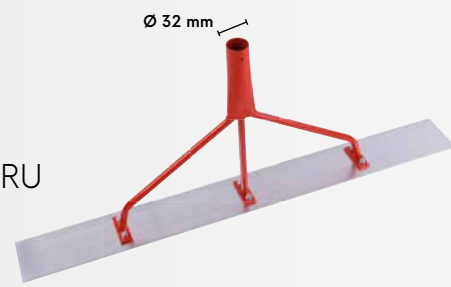

| Nu.   | specificatie               |   |
|-------|----------------------------|---|
| 15885 | 100 x 800 mm maner Ø 32 mm | 1 |

| MATERIAL<br>SUPRAFATA    | BETON |          | OMITKA<br>PLASTER |                   |                  |                 | MATERIAL ADEZIV SAU DE IMBINARE | FINISARI FATADA | APPLICATION   |
|--------------------------|-------|----------|-------------------|-------------------|------------------|-----------------|---------------------------------|-----------------|---|
|                          | DU    | FINISARE | GAURI IN ZIDARIE  | FINISARI INTERIOZ | FINISARI ZIDARIE | FINISARI FATADE |                                 |                 |   |
| PASLA NEAGRA ( MARO,GRI) |       |          |                   | ••••              |                  | ••              |                                 |                 | Nivelarea stratului de finisare; pentru uz la finisaje cu granulatie mare                                 |
| PASLA ALBA               |       |          |                   | ••••              | ••••             | ••••            |                                 |                 | Nivelarea stratului de finisare; pentru uz la finisaje cu granulatie mare                                 |
| SPUMA FINA               |       |          |                   | ••••              | ••••             | ••••            |                                 |                 | Eliminarea surplusului de nisip din stucaturile fine; curatarea placilor dupa imbinare                    |
| SPUMA DURA               |       |          |                   | ••••              | ••••             | ••••            |                                 |                 | Eliminarea surplusului de nisip; pentru stucaturi grosiere  |
| SPUMA MOLITAN            |       |          |                   | ••••              | ••••             | ••••            |                                 |                 | Eliminarea surplusului de nisip, multumita buretelui molitan curatarea suca-<br>turilor dur este mai buna |
| BURETE DE MARE           |       |          |                   |                   | •••              |                 | ••••                            |                 | Spalarea materialului de lipire   |
| BURETE HYDRO FIN/DUR     |       |          |                   |                   | •                |                 | ••••                            |                 | Spalarea materialului de lipire   |
| BURETE                   |       |          |                   | ••                | ••••             | ••              | ••••                            |                 | Spalarea materialului de lipire, asigurarea tencuielilor fine; gletuire.                                  |
| CAUCIUC                  |       |          |                   |                   |                  |                 | ••••                            |                 | Aduna materialul de lipire in zona lipirii  |
| SPUMA CAUCIUCATA         |       |          |                   |                   |                  |                 | ••••                            |                 | Aduna materialul de lipire in zona lipirii  |
| BURETE TIP MIRELON       |       | ••••     | •••               |                   |                  |                 |                                 |                 | Folosita la aplicarea cimentului acopera gaurile din zidarie  |
| BURETE TIP DUREN         |       |          |                   | ••••              | ••               | ••••            |                                 |                 | Potrivita pentru tencuieli fine; finisare.  |
| LEMN                     | ••••  | ••••     | ••••              |                   |                  |                 |                                 |                 | Folosita la aplicarea cimentului acopera gaurile din zidarie  |
| PLACA DE OTEL            | ••    | ••••     |                   | ••                |                  | ••••            | ••                              |                 | Netezirea cimentului in locuri inaccesibile.  |
| POLISTIREN               | •••   | ••••     | •••               | ••                |                  | ••              |                                 |                 | Folosita la aplicarea cimentului acopera gaurile din zidarie  |
| POLIURETAN               | ••••  | ••••     | ••••              |                   |                  |                 |                                 |                 | Folosita la aplicarea cimentului acopera gaurile din zidarie  |
| ABS                      |       | ••       |                   | ••••              | ••••             | ••••            | ••••                            |                 | Uniformizarea pe suprafata a adezivilor,tencuielilor..etc   |
| OTEL NETED               |       |          |                   | ••••              | ••••             | ••••            | ••••                            |                 | Uniformizarea pe suprafata a adezivilor,tencuielilor..etc   |
| OTEL INOXIDABIL CU DINTI |       |          |                   |                   |                  |                 | ••••                            |                 | Uniformizarea pe suprafata a adezivilor,tencuielilor..etc   |
| RAZUIITOR                |       |          | ••                |                   |                  |                 | ••••                            |                 | Razuirea polistirenului si a adezivilor de ciment.  |
| RAZUIITOR                |       |          | ••                |                   |                  |                 | ••••                            |                 | Razuirea polistirenului si a adezivilor de ciment.  |

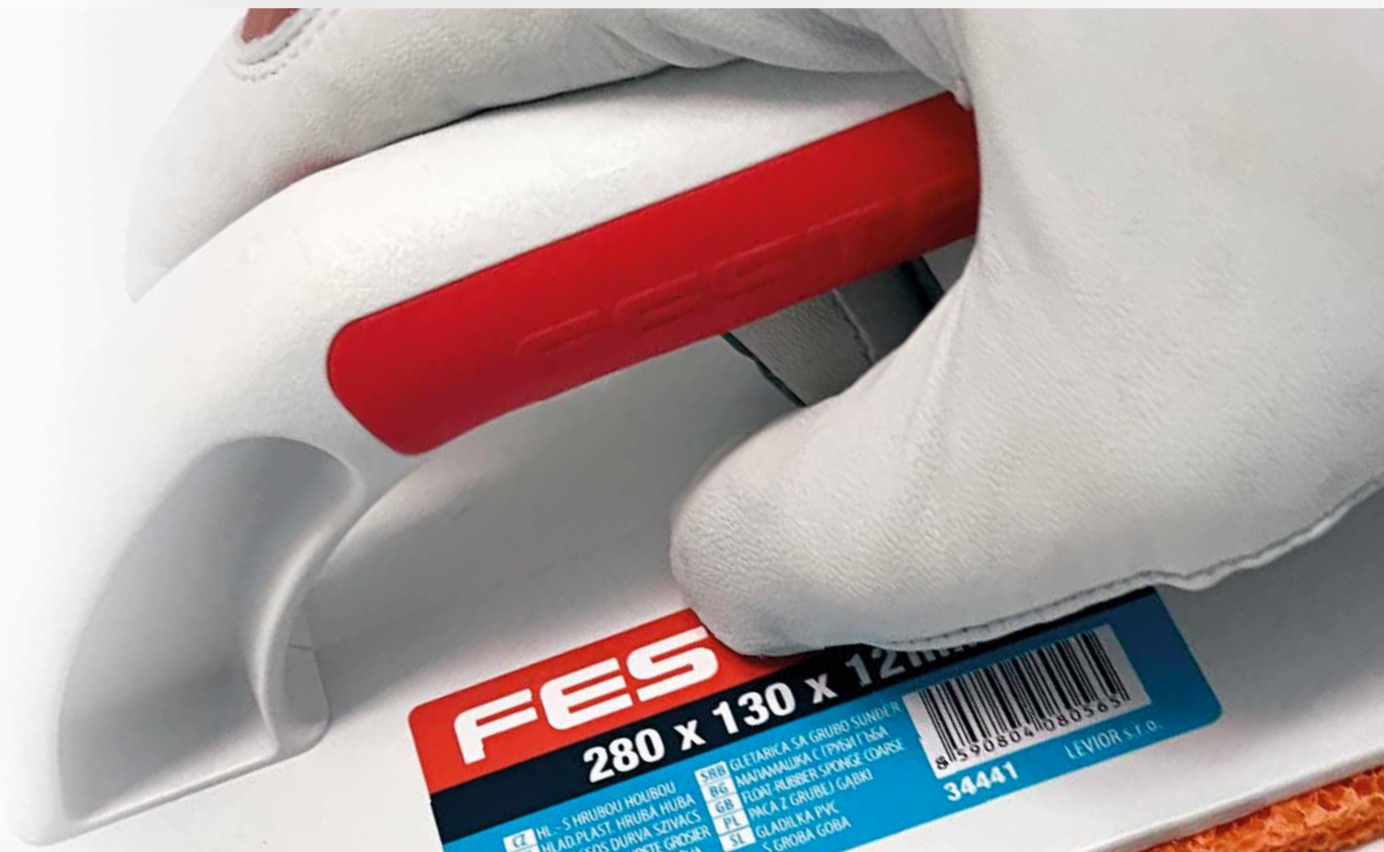
**FESTA****GLETIERA  
CU CAUCIUC**

| Č.p.  | specifikace      |    |
|-------|------------------|----|
| 34400 | 280 x 140 x 8 mm | 15 |
| 34415 | 250 x 130 x 8 mm | 15 |
| 34450 | 220 x 130 x 8 mm | 15 |
| 34445 | 220 x 70 x 8 mm  | 20 |

**FESTA****GLETIERA  
CU PASLA**

| Č.p.  | specifikace       |    |
|-------|-------------------|----|
| 34401 | 280 x 140 x 10 mm | 15 |
| 34416 | 250 x 130 x 10 mm | 15 |
| 34451 | 220 x 130 x 10 mm | 15 |
| 34446 | 220 x 70 x 10 mm  | 20 |

**FESTA****GLETIERA  
CU BURETE  
MOLITAN**

| Č.p.  | specifikace       |    |
|-------|-------------------|----|
| 34404 | 280 x 140 x 30 mm | 10 |
| 34485 | 280 x 130 x 20 mm | 10 |
| 34486 | 250 x 130 x 30 mm | 10 |
| 34419 | 250 x 130 x 20 mm | 10 |
| 34453 | 220 x 130 x 20 mm | 10 |
| 34447 | 220 x 70 x 20 mm  | 10 |

**FESTA****GLETIERA  
CU BURETE**

| Č.p.  | specifikace       |    |
|-------|-------------------|----|
| 34405 | 280 x 140 x 18 mm | 15 |
| 34420 | 250 x 130 x 18 mm | 15 |
| 34454 | 220 x 130 x 18 mm | 15 |
| 34449 | 220 x 70 x 18 mm  | 20 |
| 34480 | 280 x 140 x 12 mm | 15 |
| 34481 | 250 x 130 x 12 mm | 15 |
| 34482 | 220 x 130 x 12 mm | 15 |

**FESTA****GLETIERA  
CU BURETE  
MOLITAN**

| Nu.   | specificatie      |    |
|-------|-------------------|----|
| 34443 | 280 x 140 x 12 mm | 15 |
| 34442 | 250 x 130 x 12 mm | 15 |

**FESTA****GLETIERA  
CU BURETE  
MOLITAN**

| Nu.   | specificatie      |    |
|-------|-------------------|----|
| 34441 | 280 x 140 x 12 mm | 15 |
| 34440 | 250 x 130 x 12 mm | 15 |
| 34439 | 250 x 130 x 18 mm | 15 |



**FESTA**

GLETIERA  
CU BURETE  
MOLITAN



| Nu.   | specificatie      |    |
|-------|-------------------|----|
| 34409 | 280 x 140 x 30 mm | 10 |
| 34425 | 250 x 130 x 20 mm | 10 |

**FESTA**

GLETIERA  
CU BURETE  
MOLITAN



| Nu.   | specificatie      |    |
|-------|-------------------|----|
| 34410 | 280 x 140 x 30 mm | 10 |
| 34426 | 250 x 130 x 20 mm | 10 |

**FESTA**

GLETIERA  
CU BURETE



| Č.p.  | specificace       |    |
|-------|-------------------|----|
| 34406 | 280 x 140 x 30 mm | 10 |
| 34421 | 250 x 130 x 30 mm | 10 |
| 34455 | 220 x 130 x 30 mm | 10 |

**FESTA**

GLETIERA  
CU BURETE



| Č.p.  | specificace       |    |
|-------|-------------------|----|
| 34413 | 280 x 140 x 30 mm | 10 |
| 34428 | 250 x 130 x 30 mm | 10 |

**FESTA**

GLETIERA  
CU BURETE



| Č.p.  | specificace       |    |
|-------|-------------------|----|
| 34412 | 280 x 140 x 30 mm | 10 |
| 34424 | 250 x 130 x 30 mm | 10 |
| 34458 | 220 x 130 x 30 mm | 10 |

**FESTA**

GLETIERA  
CU BURETE



| Č.p.  | specificace       |    |
|-------|-------------------|----|
| 34490 | 280 x 140 x 30 mm | 10 |
| 34491 | 250 x 130 x 30 mm | 10 |

**FESTA**

GLETIERA  
CU BURETE



| Č.p.  | specificace       |    |
|-------|-------------------|----|
| 34411 | 280 x 140 x 30 mm | 10 |
| 34423 | 250 x 130 x 30 mm | 10 |
| 34457 | 220 x 130 x 30 mm | 10 |

**FESTA**

GLETIERA  
CU CAUCIUC



| Č.p.  | specificace       |    |
|-------|-------------------|----|
| 34402 | 280 x 140 x 10 mm | 15 |
| 34417 | 250 x 130 x 10 mm | 15 |
| 34452 | 220 x 130 x 10 mm | 15 |

**FESTA**

GLETIERA  
CU CAUCIUC



| Č.p.  | specificace      |    |
|-------|------------------|----|
| 34403 | 280 x 140 x 8 mm | 15 |
| 34418 | 250 x 130 x 8 mm | 15 |
| 34496 | 220 x 130 x 8 mm | 15 |

**FESTA**

GLETIERA  
CU DUREN



| Č.p.  | specificace       |    |
|-------|-------------------|----|
| 34407 | 280 x 140 x 20 mm | 10 |
| 34422 | 250 x 130 x 20 mm | 10 |
| 34456 | 220 x 130 x 20 mm | 10 |
| 34448 | 220 x 70 x 20 mm  | 10 |

**FESTA**

GLETIERA  
CU DUREN



| Č.p.  | specificace       |    |
|-------|-------------------|----|
| 34414 | 280 x 140 x 20 mm | 10 |
| 34429 | 250 x 130 x 20 mm | 10 |

**FESTA**

GLETIERA



| Č.p.  | specificace  |    |
|-------|--------------|----|
| 30003 | 270 x 125 mm | 28 |
| 30004 | 235 x 115 mm | 35 |
| 30005 | 210 x 115 mm | 38 |
| 30007 | 210 x 60 mm  | 44 |

**FESTA**GLETIERA  
ROSTURIMADE IN  
EU

| Č.p.  | specifikace |  |
|-------|-------------|---|
| 34033 | 240 x 95 mm | 5   |

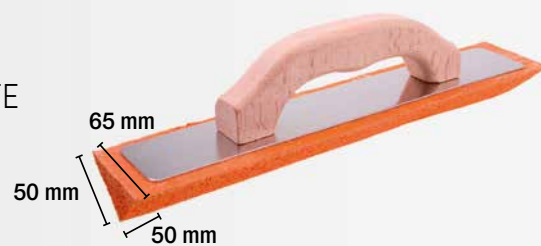
GLETIERA  
CU BURETE  
90°

| Č.p.  | specifikace |  |
|-------|-------------|---|
| 34500 | 350 mm      | 6   |

REZERVA

MADE IN  
EU

| Č.p.  | specifikace      |  |
|-------|------------------|---|
| 34241 | 280 x 140 x 8 mm | 1   |
| 34223 | 250 x 130 x 8 mm | 1   |

REZERVA PASLA

MADE IN  
EU

| Č.p.  | specifikace       |  |
|-------|-------------------|---|
| 34243 | 280 x 140 x 10 mm | 1   |
| 34221 | 250 x 130 x 10 mm | 1   |

REZERVA

MADE IN  
EU

| Č.p.  | specifikace       |  |
|-------|-------------------|---|
| 34262 | 280 x 140 x 18 mm | 1   |

REZERVA

MADE IN  
EU

| Č.p.  | specifikace       |  |
|-------|-------------------|---|
| 34251 | 280 x 140 x 30 mm | 1   |

REZERVA

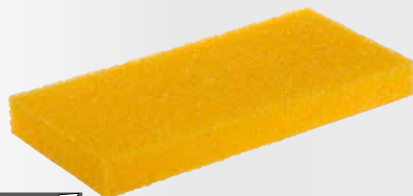
MADE IN  
EU

| Nu.   | specificatie      |  |
|-------|-------------------|---|
| 34261 | 280 x 140 x 30 mm | 1   |

REZERVA

MADE IN  
EU

| Nu.   | specificatie      |  |
|-------|-------------------|---|
| 34265 | 280 x 140 x 30 mm | 1   |

PÓTSZIVACS

MADE IN  
EU

| Nu.   | specificatie      |  |
|-------|-------------------|---|
| 34238 | 280 x 140 x 30 mm | 1   |

REZERVA

MADE IN  
EU

| Nu.   | specificatie      |  |
|-------|-------------------|---|
| 34237 | 280 x 140 x 30 mm | 1   |
| 34235 | 250 x 130 x 30 mm | 1   |

REZERVA

MADE IN  
EU

| Nu.   | specificatie      |  |
|-------|-------------------|---|
| 34231 | 280 x 140 x 10 mm | 1   |



**FESTA**

**AIKER ELECTRIC PENTRU CONSTRUIREA AMESTECURILOR**

|                                  |                  |
|----------------------------------|------------------|
| Intrare                          | 1800 W           |
| Tensiune/frecvență               | 230 V / 50 Hz    |
| Unelte                           | 2                |
| Treapta 1 (turatie la ralanti)   | 0 - 450 ot./min. |
| Treapta a 2 (turatie la ralanti) | 0 - 790 ot./min. |
| Protecție la suprasarcina        | Da               |
| Diametrul coșului de amestecare  | 100 mm           |
| Lungimea măturii                 | 570 mm           |
| Greutate                         | 5,6 kg           |



| Nu.   | specificatie                            |   |
|-------|---|---|
| 35311 | agitator                                | 1 |
| 35318 | carbon de rezervă                       | 1 |
| 35319 | agitatoare de rezervă - pereche (L + R) | 1 |



**FESTA**

**AMESTECĂTOR MATERIALE DE CONSTRUCȚIE, 1600 W**

|                                  |                   |
|----------------------------------|-------------------|
| Putere:                          | 1600 W            |
| Tensiune:                        | 230 V   50 Hz     |
| Number of gears:                 | 2                 |
| Treapta 1 (turatie la ralanti)   | 0 - 480 ot./min.  |
| Treapta a 2 (turatie la ralanti) | 0 - 800 ot./ min. |
| Protecție la suprasolicitare:    | Da                |
| Filet tel de mestecare:          | M 14              |
| Diametrul coșului de amestecat:  | 140 mm            |
| Lungimea telului de amestecare:  | 600 mm            |
| Weight:                          | 4,7 kg            |

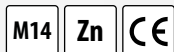

| Nu.   | specificatie      |   |
|-------|-------------------|---|
| 35310 |                   | 1 |
| 35317 | carbon de rezervă | 1 |



**FESTA**

**AMESTECĂTOR MATERIALE DE CONSTRUCȚIE, 850 W**

|                                  |                  |
|----------------------------------|------------------|
| Putere:                          | 850 W            |
| Tensiune:                        | 230 V   50 Hz    |
| Number of gears:                 | 1                |
| Treapta 1 (turatie la ralanti)   | 0 - 500 ot./min. |
| Treapta a 2 (turatie la ralanti) | -                |
| Protecție la suprasolicitare:    | Da               |
| Filet tel de mestecare:          | M 14             |
| Diametrul coșului de amestecat:  | 120 mm           |
| Lungimea telului de amestecare:  | 600 mm           |
| Weight:                          | 3,7 kg           |

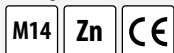

| Nu.   | specificatie      |   |
|-------|-------------------|---|
| 35300 |                   | 1 |
| 35316 | carbon de rezervă | 1 |



**WEST  
BERG****AMESTECĂTOR MATERIALE DE CONSTRUCȚIE, 1600 W**

|                                  |                    |
|----------------------------------|--------------------|
| Putere:                          | 1600 W             |
| Tensiune:                        | 230 V / 50 Hz      |
| Number of gears:                 | 2                  |
| Treapta 1 (turatie la ralanti)   | 180 - 400 ot./min. |
| Treapta a 2 (turatie la ralanti) | 300 - 700 ot./min. |
| Protecție la suprasolicitare:    | Da                 |
| Filet tel de mestecare:          | M 14               |
| Diametrul coșului de amestecat:  | 140 mm             |
| Lungimea telului de amestecare:  | 600 mm             |
| Weight:                          | 5,4 kg             |

**M14 Zn CE**

| Nu.   | specificatie      |   |
|-------|-------------------|---|
| 35305 |                   | 1 |
| 35315 | carbon de rezervă | 1 |

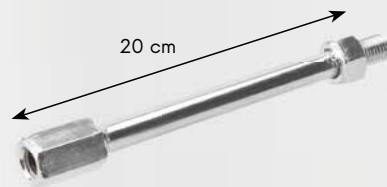
**NEW****FESTA****EXTENSIA  
MIXERULUI**

20 cm

**M14**

| Nu.   | specificatie |   |
|-------|--------------|---|
| 35142 | M14          | 1 |

**NEW****FESTA****MIXER M14 LICHIDE**

Paleta spirala cu 3 lame si prindere cu filet M14 -sens de rotire orar. Datorita faptului ca in timpul rotirii paleta impinge in jos materialul, se evita stropirea si totodata se obtine o pigmentatie uniforma a vopselelor.

| Zn | M14 | Nu.   | specificatie       |    |  |
|----|-----|-------|--------------------|----|--|
|    |     | 35085 | M14 Ø 120 x 600 mm | 12 |  |
|    |     | 35086 | M14 Ø 140 x 600 mm | 12 |  |
|    |     | 35087 | M14 Ø 160 x 600 mm | 12 |  |

**FESTA****MIXER M14 MORTAR**

Paleta spirala cu 3 lame cu prindere cu filet M14 -sens antiorar. Pentru materiale cu grad mare de vascozitate : ciment, mortar, beton, materiale de imbinare , mortare epoxidice, rasini, materiale bituminoase. In timpul rotirii paleta creaza un efect de ridicare a materialului care .genereaza o fixare si circulare a paletii in masa mixturii asemeni unui surub.

| Zn | M14 | Nu.   | specificatie       |    |  |
|----|-----|-------|--------------------|----|--|
|    |     | 35091 | M14 Ø 120 x 600 mm | 12 |  |
|    |     | 35092 | M14 Ø 140 x 600 mm | 12 |  |
|    |     | 35093 | M14 Ø 160 x 600 mm | 12 |  |

**FESTA****MIXER MORTAR**

Paleta spirala cu 2 lame pentru amestecarea cimentului si materialelor de imbinare, sapelor, mortarelor usoare, si materialelor de finisare.

| Zn | Nu.   | specificatie   |    |
|----|-------|----------------|----|
|    | 35038 | Ø 80 x 500 mm  | 24 |
|    | 35058 | Ø 100 x 500 mm | 24 |
|    | 35023 | Ø 120 x 500 mm | 24 |





**FESTA**

**MIXER SDS+ MORTAR**

Paleta spirala cu 2 lame si prindere SDS+ pentru amestecarea cimentului, materialelor de imbinare si finisare.

| SDS+ | Zn | Nu.   | specificatie   |    |
|------|----|-------|----------------|----|
|      |    | 35094 | Ø 80 x 500 mm  | 24 |
|      |    | 35095 | Ø 100 x 500 mm | 24 |
|      |    | 35096 | Ø 120 x 500 mm | 24 |



**FESTA**

**MIXER SDS+ MORTAR**

Paleta spirala cu 2 lame si prindere SDS+ pentru amestecarea cimentului, materialelor de imbinare si finisare.

| M14 | Zn | Nu.   | specificatie      |    |
|-----|----|-------|-------------------|----|
|     |    | 35059 | M14 Ø 90 x 550 mm | 24 |



**FESTA**

**MIXER SPIRALA MORTAR**

Paleta spirala cu 2 lame pentru amestecarea cimentului si materialelor de imbinare, sapelor, mortarelor usoare, si materialelor de finisare.

|  | Zn | Nu.   | specificatie   |    |
|--|----|-------|----------------|----|
|  |    | 35013 | Ø 80 x 500 mm  | 24 |
|  |    | 35006 | Ø 100 x 500 mm | 24 |
|  |    | 35007 | Ø 120 x 500 mm | 24 |

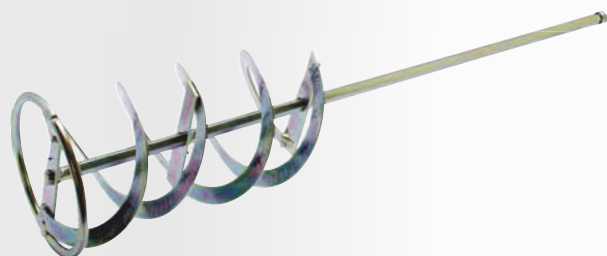

**FESTA**

**MIXER SPIRALA SDS+MORTAR**

Paleta spirala cu 2 lame pentru amestecarea cimentului si materialelor de imbinare, sapelor, mortarelor usoare, si materialelor de finisare.

| SDS+ | Zn | Nu.   | specificatie   |    |   |
|------|----|-------|----------------|----|---|
|      |    | 35012 | Ø 100 x 500 mm | 24 |  |



**FESTA**

**MIXER SPIRALA CU FILET MORTAR**

Paleta spirala cu 2 lame pentru amestecarea cimentului si materialelor de imbinare, sapelor, mortarelor usoare, si materialelor de finisare.

|  | Zn | Nu.   | specificatie   |    |
|--|----|-------|----------------|----|
|  |    | 35069 | Ø 60 x 500 mm  | 50 |
|  |    | 35078 | Ø 80 x 500 mm  | 24 |
|  |    | 35081 | Ø 100 x 500 mm | 24 |



**FESTA**

**MIXER SPIRALA CU FILET SDS+ MORTAR**

Paleta spirala cu 2 lame pentru amestecarea cimentului si materialelor de imbinare, sapelor, mortarelor usoare, si materialelor de finisare.

| SDS+ | Zn | Nu.   | specificatie   |    |
|------|----|-------|----------------|----|
|      |    | 35070 | Ø 60 x 500 mm  | 50 |
|      |    | 35079 | Ø 80 x 500 mm  | 24 |
|      |    | 35082 | Ø 100 x 500 mm | 24 |



**FESTA****MIXER SPIRALA MORTAR**

Paleta spirala cu 2 lame pentru amestecarea cimentului si materialelor de imbinare, sapelor, mortarelor usoare, si materialelor de finisare.

| Nu.          | specificatie  |    |
|--------------|---------------|----|
| <b>35048</b> | Ø 70 x 500 mm | 24 |
| <b>35068</b> | Ø 90 x 500 mm | 24 |

**FESTA****MIXER ELICOIDAL MORTAR**

Paleta mixer elicoidală pentru amestecarea materialelor cu grad mare de vascositate cum ar fi adezivii pentru constructii, mortar sau sape.

| Nu.          | specificatie  |    |
|--------------|---------------|----|
| <b>35021</b> | Ø 90 x 500 mm | 24 |

**FESTA****MIXER TIP CUSCA**

Paleta mixer tip cusca pentru amestecul materialelor unde nu este permisa intrarea aerului in mixtura. Pentru materiale fluide, folosite la finisari, etansari sau adezivi.

| Nu.          | specificatie   |    |
|--------------|----------------|----|
| <b>35015</b> | Ø 100 x 500 mm | 20 |

**FESTA****MIXER TIP ELICE**

Paleta mixer tip elice pentru amestecarea materialelor fluide; vopsele adezivi pentru tapet sau adezivi pentru placi cu grad mic de vascositate.

| Nu.          | specificatie  |    |
|--------------|---------------|----|
| <b>35011</b> | Ø 80 x 500 mm | 50 |

**MIXER LICHIDE**

Paleta zincata tip arcada pentru amestecul vopselelor lavabile sau de dispersie; adezivilor, materialelor bituminoase..etc..

| Nu.          | specificatie   |    |
|--------------|----------------|----|
| <b>35125</b> | Ø 60 x 400 mm  | 40 |
| <b>35126</b> | Ø 80 x 400 mm  | 40 |
| <b>35127</b> | Ø 100 x 600 mm | 20 |

**MIXER LICHIDE**

Paleta tip arcada cu inel pentru amestecul vopselelor lavabile, adezivilor, sapelor, sau bitumului.

| Nu.          | specificatie   |    |
|--------------|----------------|----|
| <b>35103</b> | Ø 60 x 400 mm  | 40 |
| <b>35113</b> | Ø 80 x 400 mm  | 40 |
| <b>35123</b> | Ø 100 x 600 mm | 20 |



# FESTA



## PROFESIONALE MIXERE DE CONSTRUCTII

# Lescha

Betoniera profesionala  
 Betoniera pentru uz profesional  
 Roata dintata din material de fonta cu dinti reglabili  
 Cuva atasata de sasiu cu dublu rulmenti  
 Izolatie de protectie patentat, protectie de calitate  
 conform DIN EN ISO 900  
 Finisaj de calitate superioara  
 Cuva conceputa cu un design special  
 Alimentare 220V și 380V



**Lescha**  
 BETONIERA



| Nu.   | specificatie                  |   |
|-------|-------------------------------|---|
| 35500 | Star 150 - 125 l, 230 V frână | 1 |



**Lescha**  
 BETONIERA



| Nu.   | specificatie         |   |
|-------|----------------------|---|
| 35502 | EUROMIX 125 l, 230 V | 1 |
| 35503 | EUROMIX 125 l, 400 V | 1 |



**Lescha**  
 BETONIERA



| Nu.   | specificatie          |   |
|-------|-----------------------|---|
| 35501 | BX 135 - 125 l, 230 V | 1 |



**Lescha**  
 BETONIERA



| Nu.   | specificatie           |   |
|-------|------------------------|---|
| 35504 | ABM 135 l, 230 V frână | 1 |



**Lescha**  
 BETONIERA



| Nu.   | specificatie                  |   |
|-------|-------------------------------|---|
| 35505 | SM 145 S - 140 l, 230 V       | 1 |
| 35506 | SM 145 S - 140 l, 400 V       | 1 |
| 35507 | SM 145 S - 140 l, 230 V frână | 1 |
| 35508 | SM 145 S - 140 l, 400 V frână | 1 |



**Lescha**  
 BETONIERA



| Nu.   | specificatie                  |   |
|-------|-------------------------------|---|
| 35510 | SM 165 S - 160 l, 230 V frână | 1 |
| 35511 | SM 165 S - 160 l, 400 V frână | 1 |
| 35512 | SM 165 S - 160 l, G petrol    | 1 |



**Lescha**  
 BETONIERA



| Nu.   | specificatie                  |   |
|-------|-------------------------------|---|
| 35514 | SM 185 S - 180 l, 230 V frână | 1 |
| 35515 | SM 185 S - 180 l, 400 V frână | 1 |



**Lescha**  
 BETONIERA



| Nu.   | specificatie                  |   |
|-------|-------------------------------|---|
| 35516 | S 180 HR - 180 l, 230 V frână | 1 |
| 35517 | S 180 HR - 180 l, 400 V frână | 1 |



**Lescha**  
BETONIERA



| Nu.   | specificație           |   |
|-------|------------------------|---|
| 35524 | LB 354   230 V, 1,5 kW | 1 |
| 35525 | LB 354   400 V, 1,5 kW | 1 |
| 35527 | LB 354   Honda G200    | 1 |
| 35532 | LB 404   230 V, 1,5 kW | 1 |
| 35533 | LB 404   400 V, 1,5 kW | 1 |
| 35539 | LB 484   Robin EH17B   | 1 |
| 35540 | LB 484   Honda GX160LX | 1 |
| 35542 | AT 480   400 V, 1,2 kW | 1 |

**Lescha**  
BETONIERA



| Nu.   | specificație                  |   |
|-------|-------------------------------|---|
| 35518 | S 230 HR - 230 l, 230 V frână | 1 |
| 35519 | S 230 HR - 230 l, 400 V frână | 1 |

**Lescha**  
BETONIERA



| Nu.   | specificație           |   |
|-------|------------------------|---|
| 35552 | LHB 1000   400 V       | 1 |
| 35553 | LHB 1000   HATZ Diesel | 1 |
| 35555 | LHB 1200   400 V       | 1 |



BETONIERA



| Nu.   | specificație               |   |
|-------|----------------------------|---|
| 37500 | MIX 130Zk 230 V neasamblat | 1 |
| 37501 | MIX 130Z 230 V asamblate   | 1 |
| 37505 | MK 165Bk 230 V neasamblat  | 1 |
| 37506 | MK 165B 230 V asamblate    | 1 |

**130 L**

leírás | specifi cație

|   |   |
|---|---|
| a dob térfogata   volumul tamburului    | 130 l   |
| dob sebesség   viteza tamburului        | 26±Min <sup>-1</sup>  |
| erő   putere                            | 700 W   |
| feszültség   Voltaj                     | 230 V / 50 Hz   |
| a védelem mértéke   Grad de protecție   | IP44  |
| Koszorú anyaga   Material roată dințată | lotinový   cast iron  |
| méreték   dimensiuni                    | hossz   lungime 1170 mm<br>lățime   șealéség 650 mm<br>magasság/ inaltime 1280 mm |
| súly   greutate                         | 53 kg   |

**165 L**

leírás | specifi cație

|   |   |
|---|---|
| a dob térfogata   volumul tamburului    | 165 l   |
| dob sebesség   viteza tamburului        | 23±Min <sup>-1</sup>  |
| erő   putere                            | 900 W   |
| feszültség   Voltaj                     | 230 V / 50 Hz   |
| a védelem mértéke   Grad de protecție   | IP44  |
| Koszorú anyaga   Material roată dințată | lotinový   cast iron  |
| méreték   dimensiuni                    | hossz   lungime 1295 mm<br>lățime   șealéség 735 mm<br>magasság/ inaltime 1440 mm |
| súly   greutate                         | 70 kg   |

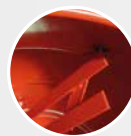

- Palete fabricate special, grosimea de 4mm



- Crapodină cu capac



- Întrerupător cu căpăcel de siguranță



- Capac de plastic acționare, roata dințată de fontă

## BETONIERA



### 125 L

| specifi cație          |                      |
|------------------------|----------------------|
| volumul tamburului     | 125 l                |
| viteza tamburului      | 26±Min <sup>-1</sup> |
| putere                 | 550 W                |
| Voltaj                 | 230 V / 50 Hz        |
| Grad de protecție      | IP44                 |
| Material roată dințată | cast iron            |
| dimensiuni             | ungime 1102 mm       |
|                        | szélesség 690 mm     |
|                        | inaltime 1310 mm     |
| greutate               | 52,5 kg              |

| Nu.   | specificație |            |   |
|-------|--------------|------------|---|
| 37509 | 126 l, 230 V | asamblate  | 1 |
| 37510 | 126 l, 230 V | neasamblat | 1 |

### 162 L

| specifi cație          |                      |
|------------------------|----------------------|
| volumul tamburului     | 162 l                |
| viteza tamburului      | 26±Min <sup>-1</sup> |
| putere                 | 650 W                |
| Voltaj                 | 230 V / 50 Hz        |
| Grad de protecție      | IP44                 |
| Material roată dințată | lotinový   cast iron |
| dimensiuni             | lungime 1180 mm      |
|                        | szélesség 710 mm     |
|                        | inaltime 1310 mm     |
| greutate               | 56 kg                |

| Nu.   | specificație |            |   |
|-------|--------------|------------|---|
| 37515 | 162 l, 230 V | neasamblat | 1 |
| 37516 | 162 l, 230 V | asamblate  | 1 |



## ROABĂ CONSTRUCȚII



| Nu.   | specificație  |                     |   |
|-------|---------------|---------------------|---|
| 37530 | 60 l, Ø 38 cm | anvelopă solidă     | 1 |
| 37532 | 60 l, Ø 40 cm | anvelopă pneumatică | 1 |

### 142 L

| specifi cație          |                      |
|------------------------|----------------------|
| volumul tamburului     | 142 l                |
| viteza tamburului      | 26±Min <sup>-1</sup> |
| putere                 | 650 W                |
| Voltaj                 | 230 V / 50 Hz        |
| Grad de protecție      | IP44                 |
| Material roată dințată | lotinový   cast iron |
| dimensiuni             | lungime 1164 mm      |
|                        | szélesség 690 mm     |
|                        | inaltime 1293 mm     |
| greutate               | 54 kg                |

| Nu.   | specificație |            |   |
|-------|--------------|------------|---|
| 37511 | 142 l, 230 V | neasamblat | 1 |
| 37512 | 142 l, 230 V | asamblate  | 1 |

### 180 L

| specifi cație          |                      |
|------------------------|----------------------|
| volumul tamburului     | 180 l                |
| viteza tamburului      | 26±Min <sup>-1</sup> |
| putere                 | 850 W                |
| Voltaj                 | 230 V / 50 Hz        |
| Grad de protecție      | IP44                 |
| Material roată dințată | lotinový   cast iron |
| dimensiuni             | lungime 1164 mm      |
|                        | szélesség 690 mm     |
|                        | inaltime 1368 mm     |
| súly   greutate        | 58 kg                |

| Nu.   | specificație |            |   |
|-------|--------------|------------|---|
| 37517 | 180 l, 230 V | neasamblat | 1 |
| 37518 | 180 l, 230 V | asamblate  | 1 |



## ROABĂ CONSTRUCȚII ZINCATĂ



| Nu.   | specificație  |                     |   |
|-------|---------------|---------------------|---|
| 37527 | 80 l, Ø 40 cm | anvelopă pneumatică | 1 |
| 37533 | 80 l, Ø 38 cm | anvelopă solidă     | 1 |

ROABĂ  
CONSTRUCȚII

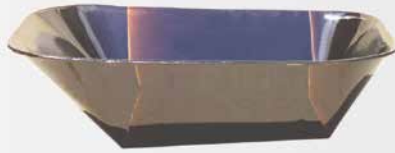

| Nu.   | specificație |   |
|-------|--------------|---|
| 37539 | 60 l         | 1 |

ROABĂ  
CONSTRUCȚII  
ZINCATĂ



| Nu.   | specificație |   |
|-------|--------------|---|
| 37541 | 80 l         | 1 |

ROATĂ



| Nu.   | specificație |                               |
|-------|--------------|-------------------------------|
| 48729 | typ AA 400   | roată gonflabilă 1            |
| 48730 | typ AA 380   | roată autoportantă 1          |
| 48731 | typ AA 380   | roată autoportantă Slovakia 1 |



ROABĂ  
CONSTRUCȚII



| Nu.   | specificație |   |
|-------|--------------|---|
| 37564 | 60 l         | 1 |

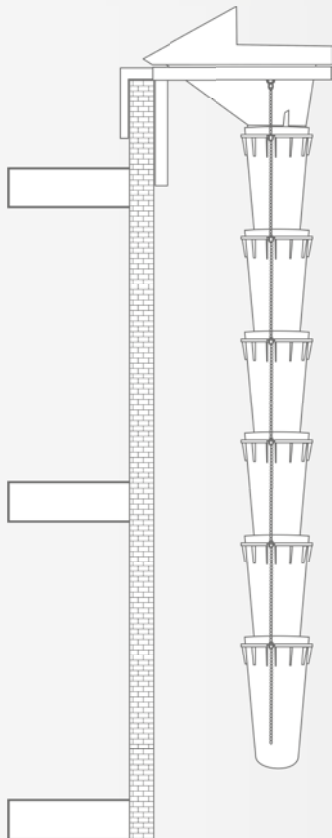

**Lescha**

SCHEAB PENTRU MOLOZ



| Nu.   | specificație  |   |
|-------|---|---|
| 35603 | diametrul de bază al căderii 50/40 cm, lungime 108 cm PE (HDPE) | 1 |
| 35604 | resturi de construcție din PE (HDPE)                            | 1 |
| 35605 | cadru suport pentru buncăr conform molozului clădirii           | 1 |

# HORIZONT®



## HORIZONT®

### DREPTAR ALU

ALU

| Nu.   | specificatie |    |
|-------|--------------|----|
| 15310 | 100 cm       | 10 |
| 15315 | 150 cm       | 10 |
| 15318 | 180 cm       | 10 |
| 15320 | 200 cm       | 10 |
| 15325 | 250 cm       | 10 |
| 15330 | 300 cm       | 10 |
| 15335 | 350 cm       | 10 |
| 15340 | 400 cm       | 10 |



## HORIZONT®

### DREPTAR ALU 1 BULA

ALU

| Nu.   | specificatie |    |
|-------|--------------|----|
| 15415 | 150 cm       | 10 |
| 15418 | 180 cm       | 10 |
| 15420 | 200 cm       | 10 |
| 15425 | 250 cm       | 10 |
| 15430 | 300 cm       | 10 |



## HORIZONT®

### DREPTAR ALU 1 BULA

ALU

| Nu.   | specificatie |    |
|-------|--------------|----|
| 15510 | 100 cm       | 10 |
| 15515 | 150 cm       | 10 |
| 15518 | 180 cm       | 10 |
| 15520 | 200 cm       | 10 |
| 15525 | 250 cm       | 10 |
| 15530 | 300 cm       | 10 |
| 15535 | 350 cm       | 10 |
| 15540 | 400 cm       | 5  |



## HORIZONT®

### DREPTAR ALU 2 MANERE

ALU

| Nu.   | specificatie |    |
|-------|--------------|----|
| 15615 | 150 cm       | 10 |
| 15620 | 200 cm       | 10 |
| 15625 | 250 cm       | 10 |
| 15630 | 300 cm       | 10 |



## HORIZONT®

### DREPTAR ALU 2 BULE + 2 MANERE

ALU

| Nu.   | specificatie |    |
|-------|--------------|----|
| 15710 | 100 cm       | 10 |
| 15715 | 150 cm       | 10 |
| 15720 | 200 cm       | 10 |
| 15725 | 250 cm       | 10 |
| 15730 | 300 cm       | 10 |
| 15735 | 350 cm       | 10 |
| 15740 | 400 cm       | 5  |







**HORIZONT**  
DREPTAR ALU PROFIL TRAPEZ

PROFIL TRAPEZOIDAL

- Profilul trapezoidal servește pentru finisarea mai fină a suprafeței
- Adecvat pentru stucatori și realizatori fațade
- Adecvat pentru tencuieli în strat subțire

| ALU | Nu.   | specificație |    |
|-----|-------|--------------|----|
|     | 15810 | 100 cm       | 10 |
|     | 15812 | 120 cm       | 10 |
|     | 15815 | 150 cm       | 10 |
|     | 15818 | 180 cm       | 10 |
|     | 15820 | 200 cm       | 10 |
|     | 15825 | 250 cm       | 10 |
|     | 15830 | 300 cm       | 10 |



**HORIZONT**  
DREPTAR ALU PROFIL H

Profil „h”

- Profilul „h” servește pentru finisarea mai fină de suprafață
- Adecvat pentru stucatori și realizatori fațade
- Adecvat pentru tencuirea cu stuc

| ALU | Nu.   | specificație |    |
|-----|-------|--------------|----|
|     | 15850 | 100 cm       | 10 |
|     | 15853 | 150 cm       | 10 |
|     | 15855 | 180 cm       | 10 |
|     | 15860 | 200 cm       | 10 |
|     | 15870 | 250 cm       | 10 |
|     | 15880 | 300 cm       | 10 |

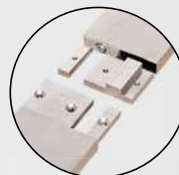

NEW

**HORIZONT**  
AMBREIAJ  
PENTRU DREPTAR  
HORIZONT

| Nu.   | specificație |   |  |
|-------|--------------|---|--|
| 15301 |              | 1 |  |



**HORIZONT**  
DREPTAR ALU 1 BULA  
REGLABIL

| Nu.   | specificație |   |  |
|-------|--------------|---|--|
| 15893 | 65 - 100 cm  | 1 |  |
| 15894 | 95 - 150 cm  | 1 |  |
| 15895 | 145 - 235 cm | 1 |  |



**HORIZONT**  
ECHER ZIDARIE

| ALU | Nu.   | specificație   |   |
|-----|-------|----------------|---|
|     | 14485 | 800 x 1200 mm  | 1 |
|     | 14486 | 1000 x 1500 mm | 1 |



**FESTA**

## ÎNDOITOR DE TIJE



| Nu.   | specificatie |   |
|-------|--------------|---|
| 26730 | Ø 6 - 14 mm  | 1 |
| 26731 | Ø 5 - 8 mm   | 1 |

## ÎNDOITOR DE TIJE

| Nu.   | specificatie      |   |
|-------|-------------------|---|
| 26735 | max Ø 13 mm 56 cm | 1 |

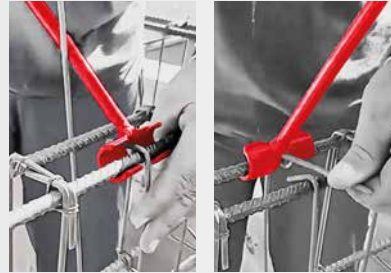
**FESTA**

## RIDICATOR CARAMIZI

| Nu.   | specificatie |    |
|-------|--------------|----|
| 60130 | 27 - 45 cm   | 10 |

## ÎNDOITOR DE TIJE

· Ø 4-8 mm

| Nu.   | specificatie |   |
|-------|--------------|---|
| 26736 |              | 1 |

**NEW****FESTA**

## RIDICATOR CARAMIZI

| Nu.   | specificatie |   |
|-------|--------------|---|
| 60132 |              | 1 |

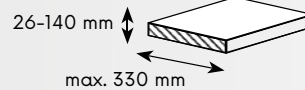
**NEW****FESTA**

## DISPOZITIV DE TĂIAT GRESIE

· max 45 kg

| Nu.   | specificatie |   |
|-------|--------------|---|
| 60125 |              | 1 |

**NEW****FESTA**

## CĂRUCIOR CU BORDURI

· max 150 kg



| Nu.   | specificatie |   |
|-------|--------------|---|
| 60157 |              | 1 |

**NEW****FESTA**

## CAMION DE PAVAJ

· max 100 kg



| Nu.   | specificatie |   |
|-------|--------------|---|
| 60155 |              | 1 |



30 - 50 cm

### RIDICATOR CARAMIZI

| Nu.   | specificație |   |
|-------|--------------|---|
| 36310 | max. 20kg    | 5 |



### DISPOZITIV DE RIDICAT BOLTARE

| specificație    | 60116       |
|-----------------|-------------|
| Grosime gresie  | 750-1000 mm |
| Lungime maximă: | 120 kg      |

| Nu.   | specificație |   |
|-------|--------------|---|
| 60116 | PRO 041      | 1 |



### BAROS PIETRAR

| specificație | 60121  | 60123  |
|--------------|--------|--------|
| inaltime:    | 200 mm | 200 mm |
| largime:     | 70 kg  | 70 kg  |
| lungime:     | 870 mm | 450 mm |
| greutate:    | 2,5 kg | 2,2 kg |

| Nu.   | specificație |   |
|-------|--------------|---|
| 60121 | 870 mm       | 1 |
| 60123 | 450 mm       | 1 |



### DISPOZITIV DE RIDICAT BOLTARE

| specificație    | 60115     |
|-----------------|-----------|
| Grosime gresie  | 80-370 mm |
| Lungime maximă: | 50 kg     |

| Nu.   | specificație |   |
|-------|--------------|---|
| 60115 | PRO 040      | 1 |



### DISPOZITIV DE RIDICAT BOLTARE

| specificație    | 60117       | 60118    |
|-----------------|-------------|----------|
| Grosime gresie  | 500-1000 mm | 0-500 mm |
| Lungime maximă: | 150 kg      | 150 kg   |

| Nu.   | specificație |   |
|-------|--------------|---|
| 60117 | PRO 042      | 1 |
| 60118 | PRO 043      | 1 |



### SUPORT REGLABIL

| Nu.   | specificație |    |
|-------|--------------|----|
| 37166 | D10 basic    | 25 |



### ZIDARSKI KOTUR

| Nu.   | specificație                  |   |
|-------|-------------------------------|---|
| 26780 | 0,5 t A cu cârling            | 1 |
| 26781 | 0,5 t B cu ochet              | 1 |
| 26782 | 0,5 t C cu cârling și protec- | 1 |
| 26783 | 0,5 t D cu ochet și protec-   | 1 |



### DISPOZITIV MANUAL DE COMPACTAT SI TASAT

| Nu.   | specificație |   |
|-------|--------------|---|
| 26740 | 12 kg        | 1 |



### CAMION DE MÂNĂ

| Nu.   | specificație  | nosnost |   |
|-------|---------------|---------|---|
| 48719 | 260 mm bantam | 250 kg  | 1 |



## MASINI DE TAIAT PLACI

- Masini de taiat placi pentru cele mai uzuale utilizari
- glisarea este asigurata de 9 rulmenti SKF
- 4 dintre ei sunt reglabili si definesc limitele cursei platou ajustabil
- Posibilitatea de asamblare, pentru mana stanga
- Toate accesoriile si service-ul sunt garantate
- Discuri taietoare, din aliaj crom-wolfram

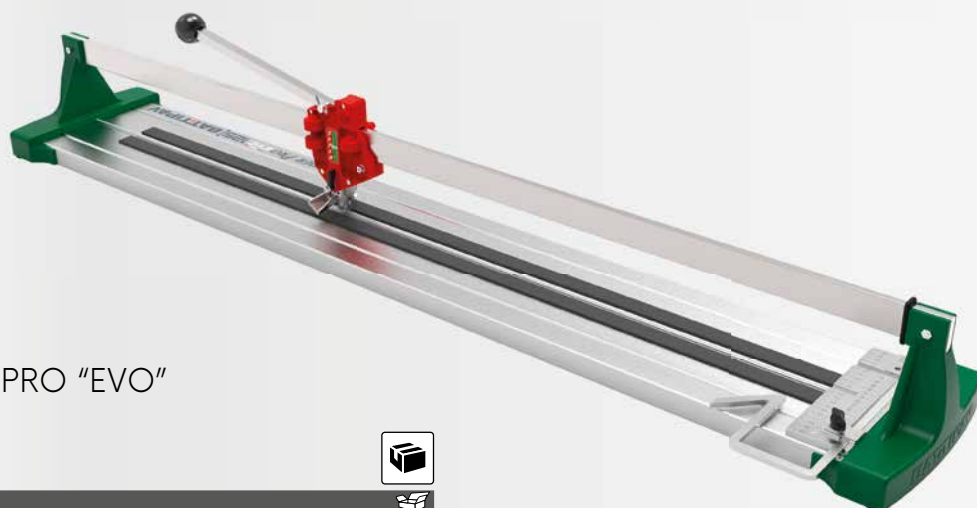

**SUPER PRO**



### MASINA DE TAIAT SUPER PRO "EVO"

· 36195 Disc de rezerva - Ø 22 mm



| Nu.   | specificatie |
|-------|--------------|
| 36191 | 1250 mm      |



1

**SUPER PRO**



### MASINA DE TAIAT

· 36195 Disc de rezerva - Ø 22 mm



| Nu.   | specificatie     |
|-------|------------------|
| 36145 | SUPER PRO 450 mm |
| 36160 | SUPER PRO 600 mm |
| 36175 | SUPER PRO 750 mm |
| 36190 | SUPER PRO 900 mm |



1



· ilustrative photo

### STAND PENTRU SUPER PRO



| Nu.   | specificatie                              |
|-------|---|
| 36200 | stand                                     |
| 36199 | stați cu elementul<br>36160, 36175, 36190 |

1

1



**FESTA**

**MASINA DE TAIAT „X”**

• 36138 Disc de rezerva - Ø 22 mm



| Nu.   | specificatie |   |
|-------|--------------|---|
| 36085 | 600 mm       | 1 |
| 36087 | 900 mm       | 1 |
| 36086 | 1300 mm      | 1 |



**NEW**

**FESTA**

**MASINA DE TAIAT**

• 36139 Disc de rezerva - Ø 22 mm



| Nu.   | specificatie |   |
|-------|--------------|---|
| 36102 | 1050 mm      | 1 |
| 36103 | 1300 mm      | 1 |
| 36105 | 1550 mm      | 1 |



**FESTA**

**MASINA DE TAIAT**

• 36195 Disc de rezerva - Ø 22 mm



| Nu.   | specificatie     |   |
|-------|------------------|---|
| 36080 | 600 mm           | 1 |
| 36081 | 750 mm           | 1 |
| 36082 | 900 mm           | 1 |
| 36076 | 750 mm asamblate | 1 |
| 36077 | 900 mm asamblate | 1 |



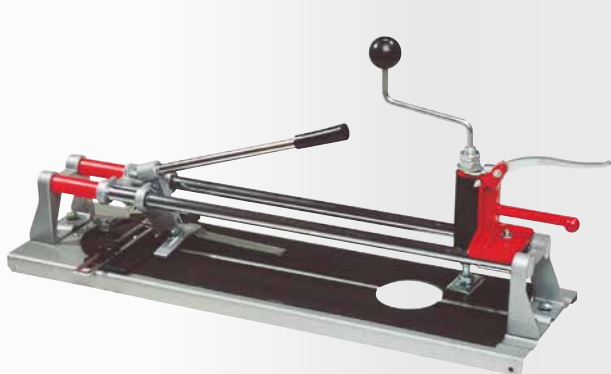

### MASINA DE TAIAT

· 36128 Disc de rezerva - Ø 16 mm



| Nu.   | specificație |   |
|-------|--------------|---|
| 36014 | 480 mm       | 4 |

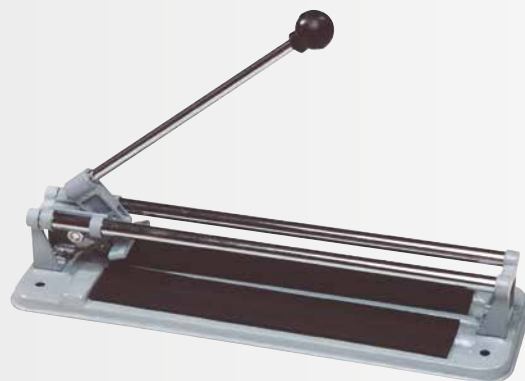

### MASINA DE TAIAT

· 36126 Disc de rezerva - Ø 15 mm



| Nu.   | specificație |    |
|-------|--------------|----|
| 36024 | 300 mm       | 10 |
| 36034 | 400 mm       | 10 |
| 36035 | 600 mm       | 4  |



### MASINA DE TAIAT

· 36136 Disc de rezerva - Ø 22 mm



| Nu.   | specificație |   |
|-------|--------------|---|
| 36036 | 480 mm       | 1 |



### DISPOZITIV MANUAL DE TAIAT PLACI

· 36136 Disc de rezerva - Ø 22,2 mm



| Nu.   | specificație |   |
|-------|--------------|---|
| 36046 | 22 mm        | 1 |

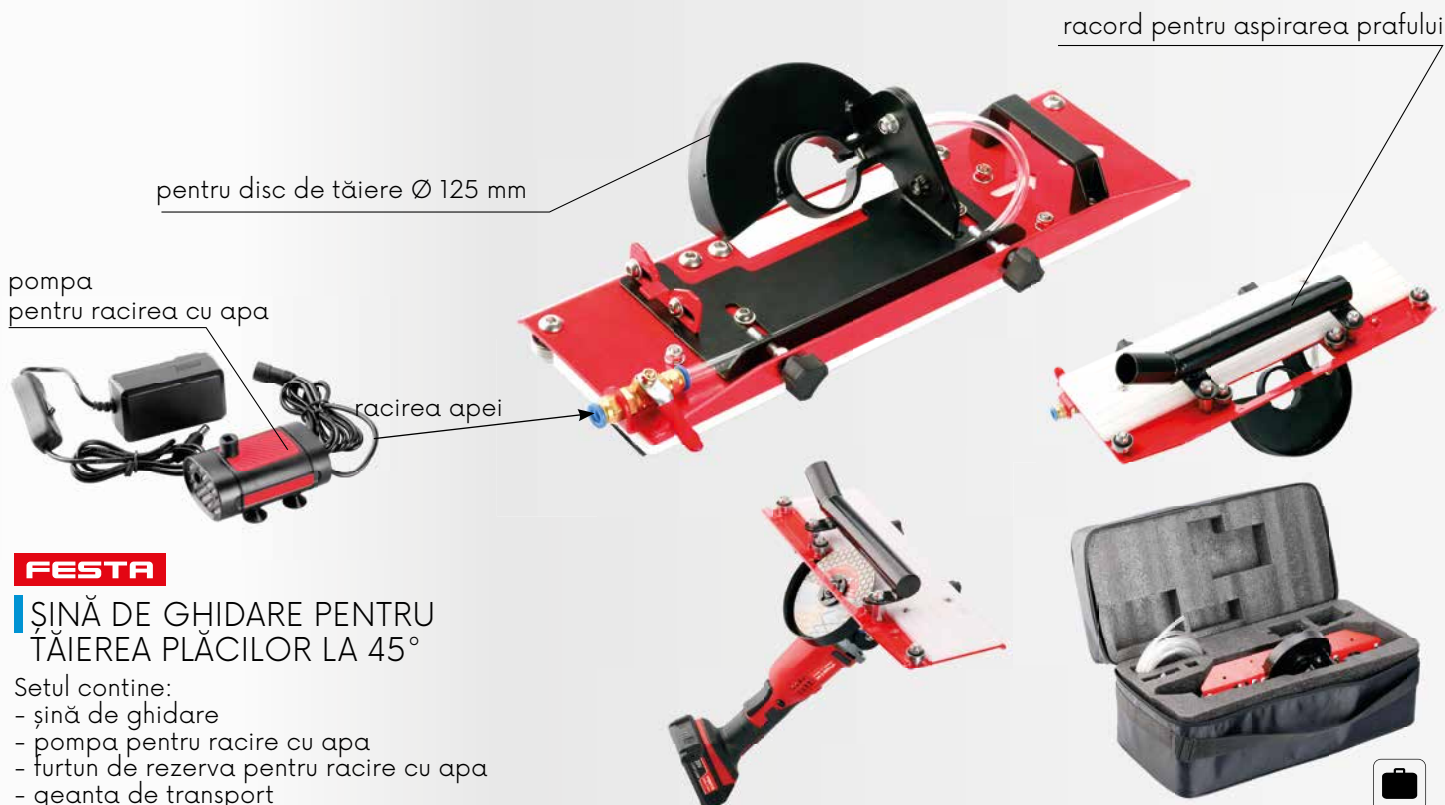

### FESTA

### ȘINĂ DE GHIDARE PENTRU TĂIEREA PLĂCILOR LA 45°

Setul conține:

- șină de ghidare
- pompa pentru racire cu apa
- furtun de rezerva pentru racire cu apa
- geanta de transport

| Nu.   | specificație |   |
|-------|--------------|---|
| 24680 |              | 1 |

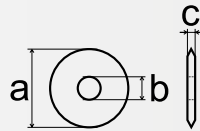

DISC DE REZERVA



| Broj  | specificacija                    |   |
|-------|----------------------------------|---|
| 36126 | a= Ø 15 mm, b= Ø 6 mm, c= 1,5 mm | 1 |
| 36128 | a= Ø 16 mm, b= Ø 6 mm, c= 3 mm   | 1 |
| 36130 | a= Ø 20 mm, b= Ø 6 mm, c= 5 mm   | 1 |
| 36136 | a= Ø 22 mm, b= Ø 6 mm, c= 2 mm   | 1 |
| 36138 | a= Ø 22 mm, b= Ø 6 mm, c= 5 mm   | 1 |
| 36139 | a= Ø 22 mm, b= Ø 6 mm, c= 6 mm   | 1 |
| 36195 | a= Ø 22 mm, b= Ø 6 mm, c= 4,8 mm | 1 |



LAME DE FERASTRUU

| Nu.   | specificatie           |   |
|-------|------------------------|---|
| 24055 | Karbid - BOSCH, MAKITA | 1 |



**FESTA**

CLESTI DE FAIANTA



| Nu.   | specificatie |   |
|-------|--------------|---|
| 36057 | 200 mm       | 6 |



CLESTI PENTRU TAIAT PLACI



| Nu.   | specificatie |    |
|-------|--------------|----|
| 36056 |              | 10 |



CLESTI PENTRU TAIAT PLACI

| Nu.   | specificatie |   |
|-------|--------------|---|
| 36059 |              | 1 |

CLESTE PENTRU PLACI

| Nu.   | specificatie |   |
|-------|--------------|---|
| 36058 | 200 mm       | 6 |



**FESTA**

ȚĂIETOR VINIL ȘI LAMINAT



| Nu.   | specificatie |   |
|-------|--------------|---|
| 36140 | 210 mm       | 4 |



NEW



FESTA

SPATULA PENTRU SILICON



| Nu.   | specificatie |
|-------|--------------|
| 37050 |              |

1

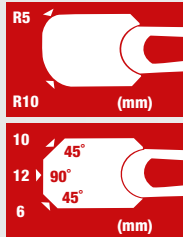

FESTA

SPATULA PENTRU SILICON



| Nu.   | specificatie |
|-------|--------------|
| 16056 | 145 mm       |

50

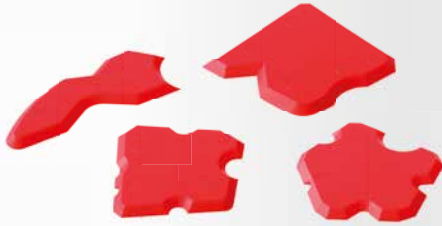

SPATULA PENTRU SILICON

4x



| Nu.   | specifications |
|-------|----------------|
| 37052 |                |

1



SPATULA PENTRU SILICON

4x



| Nu.   | specificatie |
|-------|--------------|
| 37053 |              |

48



SPATULA PENTRU SILICON

| Nu.   | specificatie |
|-------|--------------|
| 37054 |              |



1



SPATULA PENTRU SILICON

· pentru îmbinarea ferestrelor

| Nu.   | specificatie |
|-------|--------------|
| 37055 |              |



1



SQUEEGEE

| Nu.   | specificatie |    |
|-------|--------------|----|
| 37011 | 180 mm       | 12 |
| 37021 | 280 mm       | 12 |



12

12



37028



37029

BURETE BLOC 160 X 110 X 60 MM

| Nu.   | specificatie |   |
|-------|--------------|---|
| 37028 | Burete       | 1 |
| 37029 | Burete bloc  | 1 |



37025



37026

BURETE BLOC 200 X 100 X 100 MM

| Nu.   | specificatie        |   |
|-------|---------------------|---|
| 37025 | Burete molitan bloc | 1 |
| 37026 | Burete bloc         | 1 |



VAS PENTRU ZUGRAVI

| Nu.   | specificatie |   |
|-------|--------------|---|
| 37117 | set          | 1 |
| 90070 | vas 25 l     | 1 |

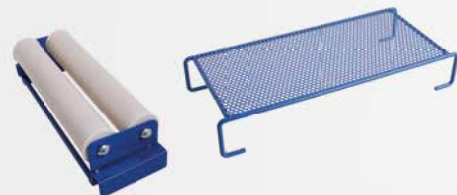

GRILAJ, ROLE

| Nu.   | specificatie |   |
|-------|--------------|---|
| 90072 | grilaj       | 1 |
| 90071 | role         | 1 |





4 mm

RAZUITOR

| Nu.   | specificație |   |
|-------|--------------|---|
| 37012 |              | 1 |



RAZUITOR CU CARBURI

| Nu.   | specificație          |    |
|-------|-----------------------|----|
| 37006 | 30 mm                 | 20 |
| 37007 | 50 mm                 | 20 |
| 37008 | lama de rezervă 30 mm | 50 |
| 37009 | lama de rezervă 50 mm | 50 |



ȘET PENTRU APLICAREA ȘI ÎNDEPĂRTAREA SILICONULUI

| Nu.   | specificație |    |
|-------|--------------|----|
| 16042 |              | 12 |

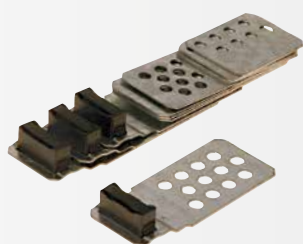

MAGNETI PENTRU PLACI

| Nu.   | specificație |   |
|-------|--------------|---|
| 38920 |              | 1 |



MAGNETI PENTRU PLACI

| Nu.   | specificație |    |
|-------|--------------|----|
| 38923 |              | 24 |



COLTARE CU FIR DE NIVEL

| Nu.   | specificație |    |
|-------|--------------|----|
| 38919 |              | 50 |



PISTOLE SPĂROVACÍ

volum 1,5 l

| Nu.   | specificație |    |
|-------|--------------|----|
| 38026 | 5x tip       | 25 |



PLASA CONICA PENTRU UMPLUT ROST

| Nu.   | specificație |   |
|-------|--------------|---|
| 38042 | 3x tip       | 6 |

NEW

- Ø 10 mm
- Ø 14 mm
- Ø 20 mm
- Ø 10 x 35 mm



FESTA APLIKATOR

| Nu.   | specificație |   |
|-------|--------------|---|
| 38045 |              | 1 |





### SET ASAMBLARE PARCHET LAMINAT

24x

| Nu.   | specificatie | buc |
|-------|--------------|-----|
| 52130 |              | 1   |



### PENE LEMN

50x

| Nu.   | specificatie        | buc |
|-------|---------------------|-----|
| 37210 | 95 x 45 x 15 - 0 mm | 50  |
| 37211 | 70 x 30 x 8 - 0 mm  | 50  |



### PUMP WEDGE

· dimensiuni 15x17 cm  
· max. înălțime 5 cm

| Nu.   | specificatie | buc |
|-------|--------------|-----|
| 37220 |              | 1   |

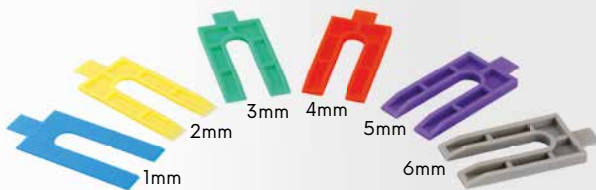

### DISTANȚIERE

30x

| Nu.   | specificatie                        | buc |
|-------|-------------------------------------|-----|
| 37212 | 1 - 6 mm, 5 buc de orice dimensiune | 1   |

### FESTA PENE LEMN



| Nu.   | specificatie         | buc |
|-------|----------------------|-----|
| 37204 | 55 x 20 x 0 - 6 mm   | 20  |
| 37203 | 65 x 18 x 0 - 12 mm  | 20  |
| 37202 | 80 x 25 x 3 - 10 mm  | 20  |
| 37201 | 100 x 25 x 1 - 16 mm | 14  |
| 37200 | 150 x 25 x 1 - 25 mm | 8   |



### FESTA PENE PLASTIC

| Nu.   | specificatie | buc |
|-------|--------------|-----|
| 37155 | 0 - 8 mm     | 30  |
| 37156 | 0 - 4 mm     | 100 |
| 37157 | 2,5 - 8 mm   | 30  |



### FESTA PENE PLASTIC

250x

| Nu.   | specificatie       | buc |
|-------|--------------------|-----|
| 37205 | 55 x 8 x 0 - 10 mm | 250 |



**NIVELYS**  
LEVELING SYSTEM  
**FESTA**

### PROFIL FUNDATIE SUB PLACARE

ALU

| Nu.   | specificatie | buc |
|-------|--------------|-----|
| 37105 | 50 cm        | 1   |
| 37106 | 100 cm       | 1   |
| 37107 | 150 cm       | 1   |

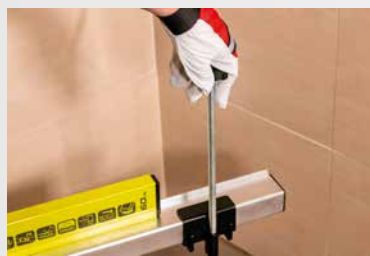

NEW



**NIVELYS**  
LEVELING SYSTEM  
**FESTA**

### PICIOARE REGLABILE PENTRU PROFILUL FUNDATIEI

· max. 50 kg

2x

| Nu.   | specificatie | buc |
|-------|--------------|-----|
| 37102 |              | 1   |

# NIVELYS

LEVELING SYSTEMS

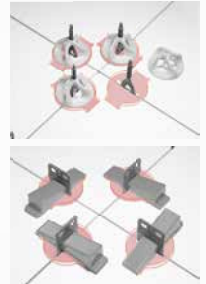

NIVELYS  
LEVELING SYSTEMS FESTA

## CLEMĂ DISTANȚIERĂ FILETATĂ

50x

| Nu.   | specificație | buc |
|-------|--------------|-----|
| 37131 | 1 mm         | 40  |
| 37132 | 2 mm         | 40  |

NIVELYS  
LEVELING SYSTEMS FESTA

## PĂLĂRIE DE NIVELARE CU FIR

50x

| Nu.   | specificație | buc |
|-------|--------------|-----|
| 37130 |              | 15  |

NIVELYS  
LEVELING SYSTEMS FESTA

## PLACI DE PROTECȚIE PENTRU SISTEME DE NIVELARE A PLACII

100x

| Nu.   | specificație | buc |
|-------|--------------|-----|
| 37192 |              | 1   |

NIVELYS  
LEVELING SYSTEMS FESTA

## DISTANȚIERE LEVEL

pene de nivelare 3715, 3716

50x

| Nu.   | specificație | buc | buc |
|-------|--------------|-----|-----|
| 37170 | 1 mm         | 50  | 60  |
| 37171 | 2 mm         | 50  | 60  |
| 37172 | 3 mm         | 50  | 60  |

NIVELYS  
LEVELING SYSTEMS FESTA

## DISTANȚIERE LEVEL

100x

| Nu.   | specificație | buc | buc |
|-------|--------------|-----|-----|
| 37185 | 1 mm         | 100 | 1   |
| 37190 | 1,5 mm       | 100 | 1   |
| 37186 | 2 mm         | 100 | 1   |
| 37187 | 3 mm         | 100 | 1   |
| 37188 | 4 mm         | 100 | 1   |
| 37189 | 5 mm         | 100 | 1   |

NIVELYS  
LEVELING SYSTEMS FESTA

## DISTANȚIERE LEVEL

100x

| Nu.   | Specificație | buc |
|-------|--------------|-----|
| 37162 | 1,5 mm       | 1   |

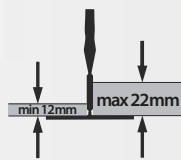

NIVELYS  
LEVELING SYSTEMS FESTA

## PENE DE NIVELARE

| Nu.   | buc | buc |
|-------|-----|-----|
| 37175 | 50  | 40  |
| 37176 | 400 | 3   |

NIVELYS  
LEVELING SYSTEMS FESTA

**NIVELYS**  
LEVELING SYSTEMS **FESTA**

### DISTANȚIERE LEVEL

600x

| Nu.   | specificație | buc | krabice         |   |
|-------|--------------|-----|-----------------|---|
| 37125 | 1 mm         | 600 | 38 x 28 x 19 cm | 1 |
| 37126 | 1,5 mm       | 600 | 38 x 28 x 19 cm | 1 |
| 37127 | 2 mm         | 600 | 38 x 28 x 19 cm | 1 |



**NIVELYS**  
LEVELING SYSTEMS **FESTA**

### DISTANȚIERE LEVEL + PENE DE NIVELARE

| Nu.   | specificație |                   |   |
|-------|--------------|-------------------|---|
| 37173 | 1 mm,        | 400 buc + 200 buc | 1 |
| 37174 | 1,5 mm,      | 400 buc + 200 buc | 1 |

**NIVELYS**  
LEVELING SYSTEMS **FESTA**

### CLESTE PENE

| Nu.   |  |   |
|-------|--|---|
| 37177 |  | 1 |

**NIVELYS**  
LEVELING SYSTEMS **FESTA**

### CLESTE PENE

| Nu.   |  |   |
|-------|--|---|
| 37178 |  | 1 |

### CLEMĂ DE NIVELARE

50x

| Nu.   | specificație |    |
|-------|--------------|----|
| 37199 | 1,5 mm       | 40 |



**NIVELYS**  
LEVELING SYSTEMS **FESTA**

### DISTANȚIERE PLASTIC

· reutilizabil

100x

| Nu.   | specificație | buc |    |
|-------|--------------|-----|----|
| 37195 | 1,0 mm       | 100 | 12 |
| 37196 | 1,5 mm       | 100 | 12 |
| 37197 | 2 mm         | 100 | 12 |
| 37198 | 3 mm         | 100 | 12 |

**FESTA**

### DISTANȚIERE PLASTIC

| Nu.   | specificație | buc |     |
|-------|--------------|-----|-----|
| 37148 | 1,0 mm       | 200 | 100 |
| 37149 | 1,5 mm       | 200 | 100 |
| 37150 | 2 mm         | 200 | 100 |
| 37151 | 2,5 mm       | 200 | 100 |
| 37152 | 3 mm         | 150 | 100 |
| 37153 | 4 mm         | 100 | 100 |
| 37154 | 5 mm         | 75  | 100 |
| 37158 | 10 mm        | 30  | 100 |

**FESTA**

### DISTANȚIERE PLASTIC

100x

| Nu.   | specificație |     |
|-------|--------------|-----|
| 37285 | 1,5 mm       | 100 |
| 37286 | 2 mm         | 100 |
| 37287 | 2,5 mm       | 100 |
| 37288 | 3 mm         | 100 |
| 37289 | 4 mm         | 100 |

**NEW**

poziție  
orizontală  
110 kg

Ø 220 mm

poziție  
verticală  
80 kg

USB-C

**FESTA**  
POWER X TOOLS

**VENTUZĂ AKU**

|                |      |       |               |       |                    |
|----------------|------|-------|---------------|-------|--------------------|
| Ø<br>220<br>mm | 80kg | 110kg | ROUGH SURFACE | USB-C | Li-ion 3.6V<br>2Ah |
|----------------|------|-------|---------------|-------|--------------------|

Nu.      specificație  
**36326**



**FESTA**

**VENTUZA PROFESIONALA  
CU POMPA DE VID SI MANOMETRU**

|                |       |       |               |
|----------------|-------|-------|---------------|
| Ø<br>200<br>mm | 140kg | 100kg | ROUGH SURFACE |
|----------------|-------|-------|---------------|

Nu.      specificație  
**36325**

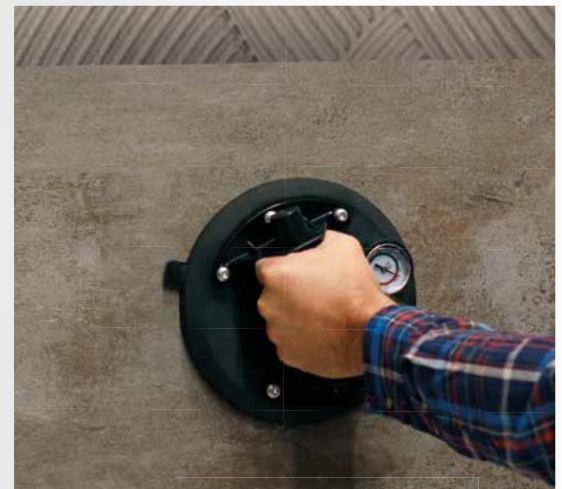

**FESTA**

**VENTUZE PLACI STICLA**

|                    |              |
|--------------------|--------------|
| poziție            | max. sarcină |
| poziție orizontală | 120 kg       |
| poziție verticală  | 150 kg       |

**ALU**

|              |              |    |
|--------------|--------------|----|
| Nu.          | specificație |    |
| <b>36318</b> | triple       | 10 |



**VENTUZE PLACI STICLA**

|              |              |    |
|--------------|--------------|----|
| Nu.          | specificație |    |
| <b>36305</b> | single       | 60 |

**FESTA**

**VENTUZE PLACI STICLA**

|                    |              |
|--------------------|--------------|
| poziție            | max. sarcină |
| poziție orizontală | 80 kg        |
| poziție verticală  | 100 kg       |

**ALU**

|              |              |    |
|--------------|--------------|----|
| Nu.          | specificație |    |
| <b>36313</b> | double       | 20 |



**VENTUZE PLACI STICLA**

|              |              |    |
|--------------|--------------|----|
| Nu.          | specificație |    |
| <b>36306</b> | double       | 20 |

**FESTA**

**VENTUZE PLACI STICLA**

|                    |              |
|--------------------|--------------|
| poziție            | max. sarcină |
| poziție orizontală | 50 kg        |
| poziție verticală  | 50 kg        |

**ALU**

|              |              |    |
|--------------|--------------|----|
| Nu.          | specificație |    |
| <b>36314</b> | single       | 20 |



**VENTUZE PLACI STICLA**

|                    |              |
|--------------------|--------------|
| poziție            | max. sarcină |
| poziție orizontală | 80 kg        |
| poziție verticală  | 100 kg       |

**ALU**

|              |              |    |
|--------------|--------------|----|
| Nu.          | specificație |    |
| <b>36319</b> | triple       | 10 |

**FESTA**

### FIR TRASAT CU PULBERE 120 G

- 6x quicker winding mechanism
- plummet line function



| Nu.   |   |
|-------|---|
| 37070 | 6 |

**FESTA**

### FIR TRASAT CU PULBERE 150 G

- 5x rulare rapida,



| Nu.   |   |
|-------|---|
| 37065 | 6 |



### FIR TRASAT CU PULBERE 180 G



| Nu.   |    |
|-------|----|
| 37069 | 10 |



### FIR DE TRASAT DIN PLASTIC



| Nu.   |    |
|-------|----|
| 37066 | 25 |



### FIR DE TRASAT CARCASA METAL

**ALU**

| Nu.   |    |
|-------|----|
| 37068 | 25 |



### FIR DE TRASAT CARCASA ABS, PLASTIC



| Nu.   |    |
|-------|----|
| 37067 | 25 |

**FESTA**

### PUDRA DE TRASAT 180 G

| Nu.   | specificatie    |    |
|-------|-----------------|----|
| 37096 | albastru        | 10 |
| 37094 | lumina albastru | 10 |
| 37097 | rosu            | 10 |
| 37095 | lumina rosu     | 10 |
| 37098 | negru           | 10 |

**FESTA**

### SFOARA ZIDARIE ROSIE



| Nu.   | specificatie |    |
|-------|--------------|----|
| 38895 | 50 m         | 24 |
| 38896 | 100 m        | 24 |

**FESTA**

### SFOARA ZIDARIE GALBENA



| Nu.   | specificatie |    |
|-------|--------------|----|
| 38899 | 50 m         | 24 |
| 38900 | 100 m        | 24 |

**FESTA**

### SFOARA 50 M



| Nu.   | specificatie |     |
|-------|--------------|-----|
| 38907 | rosu 1,0 mm  | 100 |
| 38908 | rosu 1,7 mm  | 100 |
| 38909 | rosu 2,0 mm  | 100 |



**FESTA**

SFOARA  
50 M

| Nu.   | specificație  |     |
|-------|---------------|-----|
| 38904 | galben 1,0 mm | 100 |
| 38905 | galben 1,7 mm | 100 |
| 38906 | galben 2,0 mm | 100 |



**FESTA**

SFOARA  
50 M

| Nu.   | specificație      |     |
|-------|-------------------|-----|
| 38910 | portocaliu 1,0 mm | 100 |
| 38911 | portocaliu 1,7 mm | 100 |
| 38912 | portocaliu 2,0 mm | 100 |



**FESTA**

SFOARA  
50 M

| Nu.   | specificație |     |
|-------|--------------|-----|
| 38901 | alb 1,0 mm   | 100 |
| 38902 | alb 1,7 mm   | 100 |
| 38903 | alb 2,0 mm   | 100 |



SFOARA



| Nu.   | lungime | Ø    |    |
|-------|---------|------|----|
| 50920 | 50 m    | 1 mm | 80 |



**FESTA**

FIR CU PLUMB 15 M

| Nu.   | specificație |    |
|-------|--------------|----|
| 38916 | 150 g        | 10 |
| 38917 | 300 g        | 6  |
| 38918 | 500 g        | 5  |

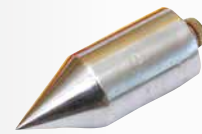

**FESTA**

PLUMB PENTRU FIR

| Nu.   | specificație |    |
|-------|--------------|----|
| 38913 | 150 g        | 10 |
| 38914 | 300 g        | 10 |
| 38915 | 500 g        | 10 |

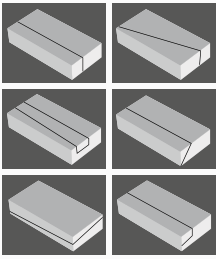

**FESTA****TĂIETOR DE POLISTIREN**

- tensiune | frecvență: 230 V / 50 Hz
- consum de energie: 200 W
- lungimea tăieturii: 137 cm
- înălțimea de tăiere: 30 cm
- protecție: IP44
- unghiul de tăiere: 0° - 90°
- echipament: suport, comutator cu picior, suport pentru șelă, 2x sârmă de tăiere Ni-Cr, perie de curățare din alamă, unelte și elemente de fixare, cutie de plastic cu roți



Nu.      Specificație

35348

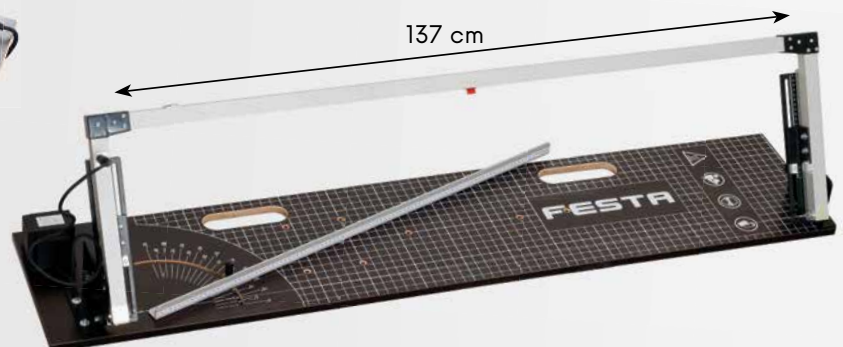
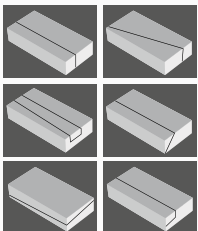

1

**FESTA****TĂIETOR DE POLISTIREN**

- tensiune | frecvență: 230 V / 50 Hz
- consum de energie: 200 W
- lungimea tăieturii: 137 cm
- înălțimea de tăiere: 30 cm
- protecție: IP44
- unghiul de tăiere: 0° - 90°
- echipament: sarma de taiere Ni-Cr, perie de curatare din alama, cheie hexagonala



Nu.      specificație

35345



1



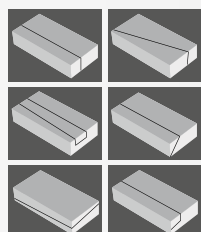

**FESTA**

### TĂIETOR DE POLISTIREN

- tensiune | frecvență: 230 V / 50 Hz
- consum de energie: 160 W
- lungimea tăieturii 120 cm
- înălțimea de tăiere 52 cm
- protecție IP44
- unghiul de tăiere 0° - 90°



· echipament: sarma de tăiere Ni-Cr, perie de curățare din alama, cheie hexagonală

Nu. specificație  
**35344**

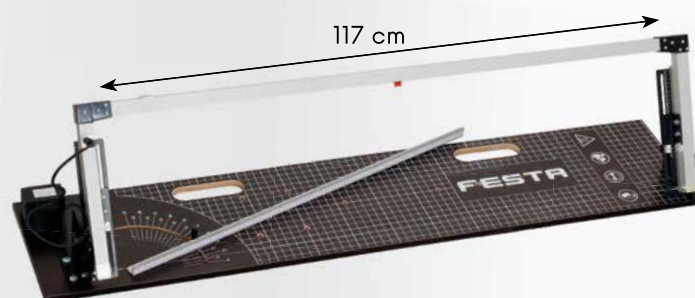
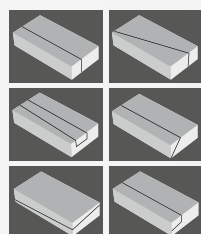

**FESTA**

### TĂIETOR DE POLISTIREN

- tensiune | frecvență: 230 V / 50 Hz
- consum de energie: 160 W
- lungimea tăieturii 120 cm
- înălțimea de tăiere 30 cm
- protecție IP44
- unghiul de tăiere 0° - 90°



· echipament: sarma de tăiere Ni-Cr, perie de curățare din alama, cheie hexagonală

Nu. specificație  
**35330**



**FESTA**

### COMUTATOR CU PICIOR PENTRU UN TĂIETOR DE POLISTIREN

pentru 35330, 35345, 35348



Nu. Specificație

**35334**

1

**FESTA**

### STAND PENTRU UN TĂIETOR DE POLISTIREN

pentru 35330, 35345, 35348



Nu. Specificație

**35336**

1

**FESTA**

### ARC DE SCHIMB PENTRU UN TĂIETOR DE POLISTIREN

pentru 35330, 35345, 35348



Nu. Specificație

**35332**

1

**FESTA**

### ADAPTOR DE ALIMENTARE DE REZERVĂ PENTRU UN TĂIETOR DE POLISTIREN

pentru 35330, 35345, 35348



tensiune/frecvență: 230 V / 50Hz

ieșire: 36 V / 5 A

putere 200 W

Nu. Specificație

**35347**

1

**FESTA**

### SUPORT PENTRU SCHELE PENTRU UN TĂIETOR DE POLISTIREN

pentru 35330, 35345, 35348



Nu. Specificație

**35333**

1



### FIR DE ÎNCĂLZIRE DE REZERVĂ NI-CR PENTRU CUTTER POLISTIREN



Nu. Specificație

**35331** 117 cm**35346** 137 cm

1





**FESTA**

**TĂIETOR DE POLISTIREN FĂRĂ FIR**

- baterie **36 V, 1,5Ah Li-ion**
- power consumption **180 W**
- temperature **max 350 C°**
- length of knife **20 cm**
- echipament: 2 baterii, încărcător, lamă, perie de alamă, hex



| Nu.   | specificație                             |   |
|-------|--|---|
| 35323 | electric polystyrene cutter              | 1 |
| 35328 | Spare knife for polystyrene cutter 14 cm | 1 |
| 35329 | Spare knife for polystyrene cutter 25 cm | 1 |

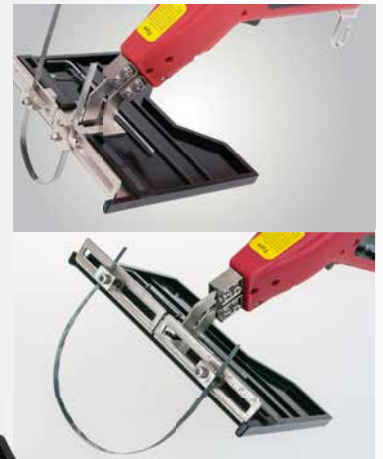

**FESTA**

**ELECTRIC POLYSTYRENE CUTTER**

- voltage / frequency **230 V/50 Hz**
- power consumption **250 W**
- temperature **50-600 C°**
- length of knife **25 cm**
- length of supply cable **3 m**



· equipment: cleaning brass brush, inbus, dlades 25 and 30 cm, case

| Nu.   | specificație                             |   |
|-------|--|---|
| 35326 | electric polystyrene cutter              | 1 |
| 35328 | Spare knife for polystyrene cutter 14 cm | 1 |
| 35329 | Spare knife for polystyrene cutter 25 cm | 1 |



**GUIDE BAR FOR POLYSTYRENE CUTTER 35326**

| Nu.   | specificație        |   |
|-------|---------------------|---|
| 35327 | Guide bar           | 1 |
| 35335 | Spare knife - 30 cm | 1 |



**FESTA**

**POLYSTYRENE ELECTRIC CUTTER**



· temperature regulation

| Nu.   | specificație |   |
|-------|--------------|---|
| 35325 | 220 W        | 1 |



**FESTA****MAȘINĂ DE FREZAT  
PENTRU POLESTIREN****ALU**

| Nu.   | specificație |   |
|-------|--------------|---|
| 24752 | Ø 65 mm      | 1 |
| 24753 | Ø 70 mm      | 1 |

**MAȘINĂ DE FREZAT PENTRU POLESTIREN**

| Nu.   | specificație |   |
|-------|--------------|---|
| 24727 | Ø 65 mm      | 1 |
| 24729 | Ø 68 mm      | 1 |
| 24728 | Ø 70 mm      | 1 |

**DIBLU PLASTIC  
PENTRU POLISTIREN****100x****MADE IN  
EU**

| Nu.   | specificație  |   | Nu.   | specificație  |   |
|-------|---------------|---|-------|---------------|---|
| 39210 | Ø 10 x 100 mm | 1 | 39218 | Ø 10 x 180 mm | 1 |
| 39212 | Ø 10 x 120 mm | 1 | 39217 | Ø 10 x 200 mm | 1 |
| 39214 | Ø 10 x 140 mm | 1 | 39219 | Ø 10 x 220 mm | 1 |
| 39216 | Ø 10 x 160 mm | 1 |       |               |   |

**FESTA****DIBLU ÎN IZOLAȚIE PT  
MANȘOANE CU ȘURUB DE PLUMB****2x**

| Nu.   | specificație |   |
|-------|--------------|---|
| 39240 | alb M10      | 1 |
| 39241 | gri M10      | 1 |
| 39242 | antracit M10 | 1 |
| 39243 | Maro M10     | 1 |
| 39244 | negru M10    | 1 |

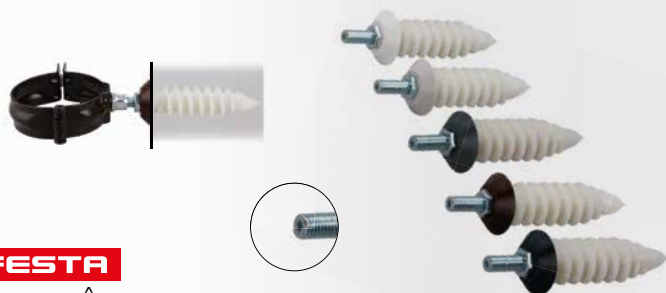
**SPALATOR IZOLAȚII**

: pentru șuruburi Ø 6 și 8 mm

**50x**

| Nu.   | Specificație |   |
|-------|--------------|---|
| 39208 | Ø 68 mm      | 1 |

**SPALATOR IZOLAȚII**

| Nu.   | specificație |     |
|-------|--------------|-----|
| 39206 | Ø 40 mm      | 200 |
| 39207 | Ø 60 mm      | 100 |

**MOQ****ROLA PLASTIC****MADE IN  
EU**

| Nu.   | diameter | spike height | lungime |    |
|-------|----------|--------------|---------|----|
| 38950 | Ø 69 mm  | 12 mm        | 25 cm   | 10 |
| 38951 | Ø 69 mm  | 12 mm        | 40 cm   | 8  |
| 38952 | Ø 122 mm | 34 mm        | 25 mm   | 10 |
| 38953 | Ø 122 mm | 34 mm        | 40 cm   | 8  |
| 38954 | Ø 122 mm | 34 mm        | 60 mm   | 4  |

**TALPA CU  
CRAMPOANE****MADE IN  
EU**

| Nu.   | specificație    |   |
|-------|-----------------|---|
| 38970 | crampoane 25 mm | 1 |
| 38971 | crampoane 30 mm | 1 |





SPALATOR IZOLATII



| Nu.   | specificație |   |
|-------|--------------|---|
| 42420 | Ø 30 mm      | 1 |



PLASĂ IZOLATI RABIO



| Nu.   | specificație           |   |
|-------|------------------------|---|
| 42312 | 1 m   50 bm 16 x 16 mm | 1 |

LEMN PENTRU TENCUIREA TENCUIELILOR



| Nu.   | lungime | grosime | lățime |    |
|-------|---------|---------|--------|----|
| 37120 | 200 mm  | 1,7 mm  | 20 mm  | 10 |
| 37119 | 250 mm  | 1,7 mm  | 20 mm  | 10 |



SITA PENTRU TENCUIALA



| Nu.   | lățime | înalt | plasă pentru ochi |   |
|-------|--------|-------|-------------------|---|
| 37216 | 50 mm  | 50 mm | 2 mm              | 1 |
| 37217 | 50 mm  | 50 mm | 3 mm              | 1 |
| 37218 | 50 mm  | 50 mm | 4 mm              | 1 |

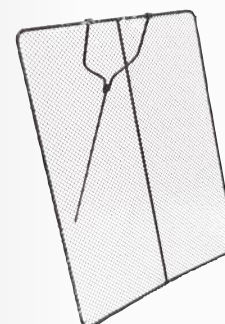

PLASA SARMA

| Nu.   | lățime | înalt | plasă pentru ochi |   |
|-------|--------|-------|-------------------|---|
| 37236 | 0,8 m  | 1 m   | 10 mm             | 1 |
| 37237 | 0,8 m  | 1 m   | 12 mm             | 1 |
| 37238 | 0,8 m  | 1 m   | 16 mm             | 1 |
| 37239 | 0,8 m  | 1 m   | 20 mm             | 1 |



FIBER RAINFORCING PENTRU CONCRETE

- +/- 150 g/ 50 kg cement
- 600 - 900 g/m<sup>2</sup> beton vagy habarcs | concrete or mortar



| Nu.   | văha   |   |
|-------|--------|---|
| 42115 | 0,9 kg | 9 |



PLASA PENTRU SCHELA

| Nu.   | specificație                          |   |
|-------|---------------------------------------|---|
| 42120 | 2,5 x 20 m, 80 g/m <sup>2</sup> VERDE | 5 |



TENCUIITOR



| Nu.   |   |
|-------|---|
| 37114 | 1 |



TENCUIITOR



| Nu.   | specificație |   |
|-------|--------------|---|
| 37115 |              | 1 |



### CÂRLIG DE FIXARE ZINCAT

| Nu.   | specificație | MOQ |
|-------|--------------|-----|
| 37231 | 14 cm single | 10  |



### CÂRLIG PENTRUJAT

| Nu.   | specificație | MOQ |
|-------|--------------|-----|
| 37232 | 14,5 cm      | 5   |



### CÂRLIG PENTRUJAT

| Nu.   | specificație | MOQ |
|-------|--------------|-----|
| 37230 | 16 cm        | 6   |

### SCOABA

| Nu.   | specificație | MOQ |
|-------|--------------|-----|
| 37233 | 320 x 10 mm  | 100 |
| 37234 | 320 x 12 mm  | 100 |



### SCOABA

| Nu.   | specificație | MOQ |
|-------|--------------|-----|
| 37235 | 250 x 12 mm  | 1   |



### CORNIER HARTIE RANFORSATA

| Nu.   | specificație   | MOQ |
|-------|----------------|-----|
| 39245 | AL 30 m x 5 cm | 1   |

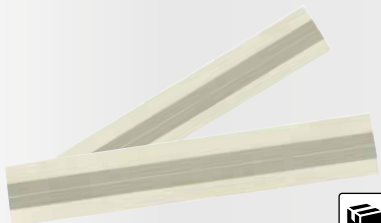

### CORNIER PLASTIC

MADE IN EU

| Nu.   | specificație | MOQ |
|-------|--------------|-----|
| 39238 | 3 m          | 25  |



### SPACLU PENTRU GIPS

| Nu.   | specificație | MOQ |
|-------|--------------|-----|
| 34308 | 50 mm        | 20  |
| 34307 | 80 mm        | 12  |
| 34306 | 100 mm       | 10  |
| 34305 | 150 mm       | 12  |



### CARLIG

· 153 - 344 cm  
· 54 kg

| Nu.   | specificație | MOQ |
|-------|--------------|-----|
| 26775 |              | 1   |



### SET PENTRU GIPS

| Nu.   | specificație  | MOQ |
|-------|---------------|-----|
| 34300 | komplet 9 buc | 10  |
| 34303 | vas           | 60  |



### FESTA SUPPORT PLĂC

| Nu.   | specificație | MOQ |
|-------|--------------|-----|
| 36312 |              | 12  |



### FESTA SUPPORT

| Nu.   | specificație       | MOQ |
|-------|--------------------|-----|
| 36308 | 36 x 16,5 x 7,5 cm | 10  |





RAZUITOARE GIPS-CARTON

| Nu.   | specificatie |    |
|-------|--------------|----|
| 22120 | 250 x 40 mm  | 10 |



RAZUITOARE GIPS-CARTON

| Nu.   | specificatie |    |
|-------|--------------|----|
| 22121 | 250 x 40 mm  | 10 |
| 22122 | 140 x 40 mm  | 6  |



RAZUITOARE GIPS-CARTON

| Nu.   | specificatie |   |
|-------|--------------|---|
| 22126 | 155 x 40 mm  | 1 |



RAZUITOARE GIPS-CARTON

| Nu.   | specificatie  |   |
|-------|---------------|---|
| 22125 | Ø 250 x 40 mm | 6 |



RAZUITOARE GIPS-CARTON

| Nu.   | specificatie  |    |
|-------|---------------|----|
| 22124 | Ø 250 x 16 mm | 10 |



RAZUITOARE GIPS-CARTON

| Nu.   | specificatie |   |
|-------|--------------|---|
| 22123 | 60 x 40 mm   | 6 |



FERASTRAU GIPS-CARTON

| Nu.   | specificatie |    |
|-------|--------------|----|
| 24159 | 150 mm       | 12 |



RINDEA GIPSCARTON

| Nu.   | specificatie    |    |
|-------|-----------------|----|
| 34315 |                 | 10 |
| 34316 | lama de rezervă | 1  |



FREZE TAIERE GIPSCARTON

| Nu.   | specificatie |    |
|-------|--------------|----|
| 24190 | 300 mm       | 10 |

REZERVE PENTRU RAZUITOARE

| Nu.   | specificatie  |    |
|-------|---------------|----|
| 22130 | 250 x 40 mm   | 20 |
| 22129 | 155 x 40 mm   | 20 |
| 22132 | 140 x 40 mm   | 20 |
| 22133 | 60 x 40 mm    | 20 |
| 22134 | Ø 16 x 250 mm | 20 |



**FESTA**  
**ARZATOR**

· Ø 17, 22, 40 mm



| Nu.   | specificatie     |    |
|-------|------------------|----|
| 69918 | 2 kW, 3 m furtun | 10 |

**FESTA**  
**ARZATOR**

· Ø 25, 35, 50 mm



| Nu.   | specificatie          |    |
|-------|-----------------------|----|
| 69919 | 19,5 kW, 1,5 m furtun | 10 |

**FESTA**  
**ARZATOR**

| Nu.   | specificatie                         |    |
|-------|--------------------------------------|----|
| 69900 | Ø 35 mm, lungime 300 mm, fara furtun | 10 |
| 69901 | Ø 35 mm, lungime 300 mm + 3 m furtun | 5  |

**FESTA**  
**ARZATOR**

| Nu.   | specificatie        |   |
|-------|---------------------|---|
| 69914 | 300 mm + 2 m furtun | 5 |

**FESTA**  
**ARZATOR**

| Nu.   | specificatie                         |    |
|-------|--------------------------------------|----|
| 69902 | Ø 55 mm, lungime 550 mm, fara furtun | 10 |

**FESTA**  
**ARZATOR**

| Nu.   | specificatie                         |    |
|-------|--------------------------------------|----|
| 69903 | Ø 55 mm, lungime 550 mm + 3 m furtun | 10 |

**FESTA**  
**ARZATOR**

| Nu.   | specificatie                         |    |
|-------|--------------------------------------|----|
| 69905 | Ø 55 mm, lungime 900 mm, fara furtun | 10 |

**FESTA**  
**ARZATOR**

| Nu.   | specificatie                         |   |
|-------|--------------------------------------|---|
| 69906 | Ø 55 mm, lungime 900 mm + 3 m furtun | 5 |





**FESTA**  
ARZATOR



· Ø 55 mm

CE **PIEZO START** TÜVRheinland  
AK 601423580004

| Nu.   | specificație              |   |
|-------|---------------------------|---|
| 69904 | 60 kW, 850 mm, 5 m furtun | 8 |

**FESTA**  
ARZATOR

· valvă reducere propan-butan  
10 and 33 kg



CE TÜVRheinland  
AK 601423580004

| Nu.   | specificație                        |   |
|-------|-------------------------------------|---|
| 69917 | Ø 60 mm, дългоść 900 mm + furtun 3m | 1 |

**FESTA**  
FURTUN PENTRU LANTERNA DE ÎNCĂLZIRE

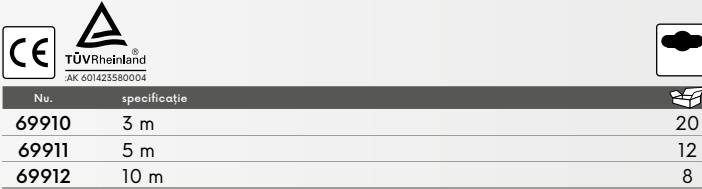

CE TÜVRheinland  
AK 601423580004

| Nu.   | specificație |    |
|-------|--------------|----|
| 69910 | 3 m          | 20 |
| 69911 | 5 m          | 12 |
| 69912 | 10 m         | 8  |



**CASCA SUDURA**

|                      |                     |
|----------------------|---------------------|
| conexiune de intrare | 25 bar              |
| presiunea de ieșire  | 0,5 - 4,0 bar       |
| debitul nominal      | 16 kg   h           |
| conexiune de intrare | W 21,8 x 1   14" LH |
| priza de conectare   | G3   8" LH          |

CE **MADE IN EU**

| Nu.   | specificație |   |
|-------|--------------|---|
| 69907 |              | 1 |



**VALVĂ REDUCȚIE PROPAN-BUTAN**

|                      |                     |
|----------------------|---------------------|
| presiunea de ieșire  | 4,0 bar             |
| debitul nominal      | 16 kg   h           |
| conexiune de intrare | W 21,8 x 1   14" LH |
| priza de conectare   | G3   8" LH          |

CE **MADE IN EU**

| Nu.   | specificație |    |
|-------|--------------|----|
| 69920 |              | 25 |



**VALVĂ REDUCȚIE PROPAN-BUTAN**

CE **MADE IN EU**

| Nu.   | specificație         |   |
|-------|----------------------|---|
| 69923 | W 21,8; G 3/8; 4 bar | 1 |



**REGULATOR PRESIUNE**

CE **MADE IN EU**

| Nu.   | specificație           |   |
|-------|------------------------|---|
| 69908 | 30 mBar, prickle       | 1 |
| 69909 | 30 mBar, thread G 1/4L | 1 |



**SUPAPA DE PREȘIUNE CU O SINGURĂ CALE**

· G 3/8L, pentru sticla de 2 kg

CE **MADE IN EU**

| Nu.   | specificație |   |
|-------|--------------|---|
| 69928 |              | 1 |

**FESTA****ARZĂTOR DE GAZ PE UN CARTUȘ FILETAT**

- temperatura max 1200 °C
- energie 1,7 kW
- diametrul arzătorului. Ø 20 mm



| Nu.   | specificație |
|-------|--------------|
| 69930 | piezo        |

20

**FESTA****ARZĂTOR DE GAZ PE CARTUȘUL PERFORANT**

- temperatura max 1200 °C
- energie 1,7 kW
- diametrul arzătorului. Ø 20 mm



| Nu.   | specificație |
|-------|--------------|
| 69931 | piezo        |

12

**VAS PENTRU GIPS**

| Nu.   | specificație |
|-------|--------------|
| 37121 | conic        |



1

**VAS PENTRU GIPS**

| Nu.   | specificație |
|-------|--------------|
| 37122 | joasa        |



1

**VAS PENTRU GIPS**

| Nu.   | specificație  |
|-------|---------------|
| 33275 | joasa, rubber |



20

**GALEATA TABLA GALVANIZATA**

| Nu.   | specificație |
|-------|--------------|
| 39000 | 5 l          |
| 39001 | 10 l         |
| 39002 | 12 l         |
| 39003 | 15 l         |



40

30

20

20

**GALEATA**

| Nu.   | specificație     |
|-------|------------------|
| 39005 | 5 l              |
| 39010 | 10 l             |
| 39012 | 12 l             |
| 39014 | 15 l cu gradatie |
| 39020 | 20 l             |
| 39021 | 20 l cu gradatie |



1

1

1

1

1

1

**GALEATA**

| Nu.   | specificație |
|-------|--------------|
| 39192 | 30 l         |
| 39193 | 45 l         |



20

20

**VAS PLASTIC**

| Nu.   | specificație      |
|-------|-------------------|
| 39045 | 45 l Ø 54 x 27 cm |
| 39065 | 60 l Ø 60 x 35 cm |
| 39090 | 90 l Ø 66 x 35 cm |



1

1

1

**VAS RECTANGULAR**

| Nu.   | specificație         |
|-------|----------------------|
| 39145 | 40 l 71 x 40 x 21 cm |
| 39165 | 65 l 71 x 40 x 30 cm |
| 39190 | 85 l 77 x 48 x 30 cm |



1

1

1

# FESTA

- impact - resistant handle  
nylon + fi berglass



- 360° rotatable head

- 3 position reverse step switch



- adjustable thrust ratio  
9:1 / 18:1



## FESTA

PISTOL SILICON  
WITH REVERSE STEP SWITCH  
AND ADJUSTABLE THRUST RATIO

Nu. specificatie

38027



1

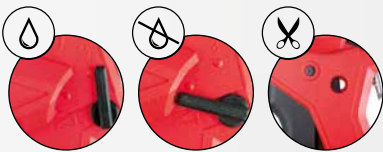

NEW



## FESTA

PISTOL SILICON  
WITH REVERSE  
STEP  
SWITCH



Č.p. Specificace

38032 nylonová

24



## FESTA

PISTOL SILICON  
WITH REVERSE  
STEP  
SWITCH



Nu. specificatie

38028



1

## FESTA

PISTOL  
SILICON



Nu. specificatie

38013



12

## FESTA

PISTOL  
SILICON



Nu. specificatie

38001



24

## FESTA

PISTOL  
SILICON



Nu. specificatie

38012



6

## FESTA

PISTOL  
SILICON



Nu. specificatie

38024



1

PISTOL  
SILICON



| Nu.   | specificatie |    |
|-------|--------------|----|
| 38010 | 6 square     | 24 |

PISTOL  
SILICON



| Nu.   | specificatie |    |
|-------|--------------|----|
| 38025 |              | 24 |

**FESTA**

PISTOL  
PENTRU  
FIXARI  
CHIMICE



| Nu.   | specificatie |    |
|-------|--------------|----|
| 38020 |              | 12 |

PISTOL  
SILICON



| Nu.   | specificatie |    |
|-------|--------------|----|
| 38006 |              | 12 |

PISTOL  
SILICON



| Nu.   | specificatie |    |
|-------|--------------|----|
| 38002 | 6 square     | 24 |

PISTOL  
SILICON



| Nu.   | specificatie |    |
|-------|--------------|----|
| 38003 | 6 square     | 24 |

PISTOL  
SILICON



| Nu.   | specificatie |    |
|-------|--------------|----|
| 38007 |              | 24 |

PISTOL  
SILICON



| Nu.   | specificatie |    |
|-------|--------------|----|
| 38008 |              | 24 |

PISTOL  
SILICON



| Nu.   | specificatie |    |
|-------|--------------|----|
| 38009 |              | 24 |

PISTOL  
SILICON



| Nu.   | specificatie |    |
|-------|--------------|----|
| 38000 |              | 24 |

**FESTA**

PISTOL  
SILICON



ALU

| Nu.   | specificație |     |
|-------|--------------|-----|
| 38005 | 310 ml       | 20  |
| 38014 | tip 3 buc    | 100 |

**FESTA**

PISTOL  
SILICON



ALU

| Nu.   | specificație |     |
|-------|--------------|-----|
| 38004 | 600 ml       | 12  |
| 38014 | tip 3 buc    | 100 |

**FESTA**

PISTOL  
SPUMA  
POLIURETANICA  
TEFLON



TEFLON

| Nu.   | specificație |    |
|-------|--------------|----|
| 38018 |              | 20 |

**FESTA**

PISTOL  
SPUMA  
POLIURETANICA  
TEFLON



TEFLON

| Nu.   | specificație |    |
|-------|--------------|----|
| 38017 |              | 20 |

**FESTA**

PISTOL METALIC  
PENTRU  
SPUMA



TEFLON

| Nu.   | specificație |    |
|-------|--------------|----|
| 38016 |              | 20 |

**FESTA**

PISTOL  
PENTRU  
SPUMA PUR



TEFLON

| Nu.   | specificație |    |
|-------|--------------|----|
| 38015 |              | 20 |

PISTOL  
PENTRU  
SPUMA PUR



| Nu.   | specificație |    |
|-------|--------------|----|
| 38031 |              | 20 |

**FESTA**

PISTOL  
PENTRU  
SPUMA PUR



| Nu.   | specificație |    |
|-------|--------------|----|
| 38022 | ABS          | 20 |

PISTOL  
PENTRU  
SPUMA PUR



| Nu.   | specificație |    |
|-------|--------------|----|
| 38021 |              | 24 |

DUZA DE SCHIMB  
PENTRU PISTOL SPUMA  
· pistol 38015, 38016, 38017, 38018



| Nu.   | specificație |   |
|-------|--------------|---|
| 38030 |              | 5 |



## PENSULE

| Nu.   | lățime | grosime | lungime |    |
|-------|--------|---------|---------|----|
| 52212 | 20 mm  | 15 mm   | 40 mm   | 12 |
| 52213 | 30 mm  | 15 mm   | 45 mm   | 12 |
| 52214 | 40 mm  | 15 mm   | 45 mm   | 12 |
| 52215 | 50 mm  | 15 mm   | 50 mm   | 12 |
| 52216 | 60 mm  | 15 mm   | 60 mm   | 12 |
| 52217 | 70 mm  | 15 mm   | 65 mm   | 12 |
| 52218 | 80 mm  | 15 mm   | 65 mm   | 12 |
| 52220 | 100 mm | 15 mm   | 70 mm   | 12 |



## PENSULE

| Nu.   | lățime | grosime | lungime |    |
|-------|--------|---------|---------|----|
| 52202 | 20 mm  | 12,5 mm | 38 mm   | 12 |
| 52203 | 30 mm  | 13 mm   | 38 mm   | 12 |
| 52204 | 40 mm  | 14 mm   | 44 mm   | 12 |
| 52205 | 50 mm  | 16 mm   | 44 mm   | 12 |
| 52206 | 60 mm  | 17 mm   | 52 mm   | 12 |
| 52208 | 80 mm  | 17 mm   | 52 mm   | 12 |
| 52207 | 100 mm | 18 mm   | 52 mm   | 12 |

PENSULA  
PENTRU VOPSIT CALORIFER

| Nu.   | lățime | grosime | lungime |    |
|-------|--------|---------|---------|----|
| 52283 | 25 mm  | 10 mm   | 44 mm   | 12 |
| 52284 | 38 mm  | 10 mm   | 44 mm   | 12 |
| 52285 | 50 mm  | 10 mm   | 44 mm   | 12 |
| 52286 | 62 mm  | 10 mm   | 50 mm   | 12 |
| 52288 | 76 mm  | 10 mm   | 50 mm   | 12 |



## SET PENSULE

| Nu.   | specificație  |    |
|-------|---------------|----|
| 3x    |               |    |
| 52070 | 20, 30, 50 mm | 50 |



## BIDINEA

| Nu.        | specificație |    |
|------------|--------------|----|
| MADE IN EU |              |    |
| 52075      | Ø 90 mm      | 10 |



## BIDINEA

| Nu.        | lățime | lungime |    |
|------------|--------|---------|----|
| MADE IN EU |        |         |    |
| 52076      | 170 mm | 80 mm   | 10 |



## SET PENSULE

| Nu.   | specificație                      |    |
|-------|-----------------------------------|----|
| 5x    |                                   |    |
| 52071 | 15 mm, 25 mm, 40 mm, 60 mm, 80 mm | 50 |



## BIDINEA

| Nu.   | lățime   | lungime |    |
|-------|----------|---------|----|
| 52077 | Ø 105 mm | 70 mm   | 12 |



## BIDINEA

| Nu.   | lățime | lungime |    |
|-------|--------|---------|----|
| 52078 | 170 mm | 70 mm   | 12 |

| TRAFLET    |                 | VOPSELE SI LACURI |              |        |         |          |                  |         |        |               |           |              |                |                  |
|------------|-----------------|-------------------|--------------|--------|---------|----------|------------------|---------|--------|---------------|-----------|--------------|----------------|------------------|
| MATERIAL   | DIMENSIUNI ROLA | DISPERSII         | ANTICOROZIVE | RASINI | ULEIURI | LAVABILE | VOPSELE POLIESTE | ADEZIVI | LACURI | VOPSELE LATEX | EPOXIDICE | BICOMPONENTI | VOPSELE USOARE | VOPSELE ACRILICE |
| PES        | 20              | •                 |              |        |         |          |                  | •       |        | •             |           |              | •              |                  |
| PES        | 20              | •                 | •            |        |         | •        |                  | •       |        | •             |           |              |                | •                |
| PAC        | 18              | •                 |              |        |         |          |                  | •       |        | •             |           |              |                |                  |
| PAC        | 12, 13          | •                 |              |        |         |          |                  |         |        |               |           |              |                |                  |
| PAD        | 18, 21          | •                 |              |        |         |          |                  |         |        | •             |           |              |                |                  |
| PAD        | 13              | •                 | •            |        |         |          |                  |         |        | •             |           |              |                |                  |
| BÁRÁNY     | 23              | •                 |              |        |         |          |                  |         |        | •             |           |              |                |                  |
| NYLON      | 13              |                   | •            | •      | •       | •        | •                |         |        | •             | •         | •            | •              |                  |
| VELOUR     | 4               |                   | •            | •      |         |          | •                |         |        |               | •         | •            | •              |                  |
| MICROFIBRE | 10              |                   |              |        |         | •        |                  |         | •      | •             |           |              |                |                  |
| MOLITAN    |                 |                   |              | •      |         | •        |                  |         |        |               |           |              |                | •                |

TRAFLET DIN ACRYLIC

PAC

MADE IN EU

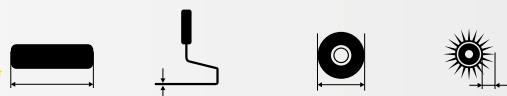

| Nu.   |        |        |         |       |    |
|-------|--------|--------|---------|-------|----|
| 52331 | 100 mm | Ø 6 mm | Ø 17 mm | 12 mm | 50 |
| 52334 | 250 mm | Ø 8 mm | Ø 48 mm | 12 mm | 10 |

TRAFLET DIN ACRYLIC

PAC

MADE IN EU



| Nu.   |           |        |        |         |       |
|-------|-----------|--------|--------|---------|-------|
| 52391 | polster 5 | 250 mm | Ø 8 mm | Ø 54 mm | 18 mm |

TRAFLET DIN ACRYLIC

PAC

MADE IN EU



| Nu.   |           |        |        |         |       |
|-------|-----------|--------|--------|---------|-------|
| 52328 | polster 5 | 250 mm | Ø 8 mm | Ø 54 mm | 18 mm |
| 52456 | polster 7 | 250 mm | Ø 8 mm | Ø 67 mm | 18 mm |

TRAFLET DIN POLYAMIDA

PAD

MADE IN EU

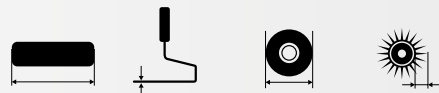

| Nu.   |           |        |        |         |       |
|-------|-----------|--------|--------|---------|-------|
| 52428 | polster 7 | 250 mm | Ø 8 mm | Ø 67 mm | 18 mm |

TRAFLET DE NYLON, PENTRU LAC

PAD

MADE IN EU



| Nu.   |        |        |         |       |    |
|-------|--------|--------|---------|-------|----|
| 52421 | 100 mm | Ø 6 mm | Ø 17 mm | 13 mm | 50 |
| 52424 | 250 mm | Ø 8 mm | Ø 48 mm | 13 mm | 10 |

TRAFLET DIN POLYESTER

PES

MADE IN EU



| Nu.   |        |        |         |       |    |
|-------|--------|--------|---------|-------|----|
| 52305 | 180 mm | Ø 6 mm | Ø 42 mm | 20 mm | 10 |
| 52306 | 250 mm | Ø 6 mm | Ø 42 mm | 20 mm | 10 |

TRAFLET DIN BURETE FINDEREPT, PENTRU LAC

MADE IN EU

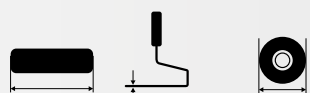

| Nu.   |     |        |        |         |    |
|-------|-----|--------|--------|---------|----|
| 52471 | ega | 100 mm | Ø 6 mm | Ø 35 mm | 50 |



## SET TRAFEALET

PAC

MADE IN EU

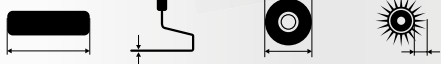

| Nu.   | specificație                          | 1 |
|-------|---------------------------------------|---|
| 52600 | polster 4 180 mm Ø 8 mm Ø 53 mm 18 mm | 1 |

## SET TRAFEALET

PES

MADE IN EU



| Nu.   | specificație                | 25 |
|-------|-----------------------------|----|
| 52610 | 180 mm Ø 6 mm Ø 42 mm 20 mm | 25 |
| 52605 | 250 mm Ø 6 mm Ø 42 mm 20 mm | 20 |

## SET TRAFEALET

- 1x trafalet PAD 13mm/10cm
- 1x trafalet PAC 12mm/10cm
- trafalet PES 11cm
- tava

MADE IN EU



| Nu.   | 10 |
|-------|----|
| 52602 | 10 |

## TRAFEALET PENTRU COLTURI, DIN POLYACRYLE

PAC

MADE IN EU

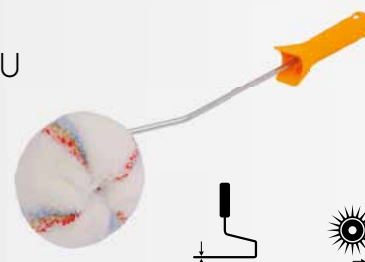

| Nu.   | specificație          | 1 |
|-------|-----------------------|---|
| 52601 | cu mâner Ø 6 mm 18 mm | 1 |

TAVA  
PENTRU VOPSEA

MADE IN EU



| Nu.   | specificație        | 1 |
|-------|---------------------|---|
| 52662 | 150 x 270 mm 100 mm | 1 |
| 52666 | 260 x 290 mm 180 mm | 1 |
| 52671 | 330 x 340 mm 250 mm | 1 |

RECIPIENT  
VOPSEA

MADE IN EU



| Nu.   | volume | 25 |
|-------|--------|----|
| 52694 | 8 l    | 25 |
| 52695 | 12 l   | 20 |

GRATAR  
PENTRU SCURS

MADE IN EU



| Nu.   | lățime | high   | 100 |
|-------|--------|--------|-----|
| 52652 | 230 mm | 250 mm | 100 |
| 52656 | 270 mm | 290 mm | 100 |

MANER  
OTEL-PLASTIC  
PENTRU  
TRAFEALET

MADE IN EU



| Nu.   | specificație            | 100 |
|-------|-------------------------|-----|
| 52640 | 5 cm   Ø 6 mm           | 100 |
| 52645 | 8,5 cm   Ø 6 mm x 27 mm | 100 |

MANER  
OTEL-PLASTIC  
PENTRU  
TRAFEALET

MADE IN EU



| Nu.   | specificație   | 100 |
|-------|----------------|-----|
| 52630 | 18 cm   Ø 6 mm | 100 |
| 52635 | 25 cm   Ø 6 mm | 100 |
| 52620 | 18 cm   Ø 8 mm | 50  |
| 52625 | 25 cm   Ø 8 mm | 50  |

## SPACLU

| Nu.   | 12 |
|-------|----|
| 37005 | 12 |



**FESTA**

**MANER TELESCOPIC**

filet pentru 31610, 34203



| Nu.   | Specificație |   |
|-------|--------------|---|
| 52011 | 88 - 140 cm  | 1 |



**MANER TELESCOPIC**

**ALU**

| Nu.   | length |     |    |
|-------|--------|-----|----|
| 52010 | 120 cm | ALU | 50 |
| 52012 | 240 cm | ALU | 25 |



**MANER TELESCOPIC**

| Nu.   | length |      |    |
|-------|--------|------|----|
| 52020 | 300 cm | otel | 10 |



**MANER TELESCOPIC**

| Nu.   | length |            |   |
|-------|--------|------------|---|
| 52030 | 240 cm | fiberglass | 6 |



**FOLIE PROTECTIE AUTOADEZIVA**

| Nu.   | lățime | lungime |    |
|-------|--------|---------|----|
| 37243 | 55 cm  | 30 m    | 60 |
| 37244 | 110 cm | 30 m    | 30 |
| 37245 | 140 cm | 30 m    | 30 |
| 37246 | 180 cm | 15 m    | 30 |
| 37290 | 210 cm | 20 m    | 30 |
| 37247 | 240 cm | 15 m    | 30 |
| 37291 | 270 cm | 16 m    | 30 |



**SALOPETA DE PROTEC. CU GLUGA**

| Nu.   | specificație |   |
|-------|--------------|---|
| 50585 | mărimea M    | 1 |
| 50586 | mărimea L    | 1 |
| 50587 | mărimea XL   | 1 |
| 50588 | mărimea XXL  | 1 |



**COPERTA PENTRU USA CU FERMOAR**

| Nu.   | specificație                                |    |
|-------|---|----|
| 37248 | 1,2 x 2,2 m<br>100 μm păska<br>45 mm x 25 m | 25 |



**FOLIE PROTECTIE**

| Nu.   | volum      | grosime    |     |
|-------|------------|------------|-----|
| 37250 | 4 x 5 m    | 0,007 mm   | 100 |
| 37251 | 4 x 12,5 m | 0,007 mm   | 50  |
| 37252 | 2 x 50 m   | 0,007 role | 20  |



**FOLIE PROTECTIE**

| Nu.   | specificație | grosime |     |
|-------|--------------|---------|-----|
| 37253 | 4 x 5 m      | 0,03 mm | 100 |



**CARTON GUDRONAT ONDULAT**

| Nu.   | lățime | lungime |   |
|-------|--------|---------|---|
| 54008 | 1 m    | 10 m    | 1 |

# FESTA



PE PRELATE PROFI

· albastru-argintiu

140 g/m<sup>2</sup>



| Nu.   | specificație |    |
|-------|--------------|----|
| 25206 | 2 x 3 m      | 25 |
| 25212 | 3 x 4 m      | 10 |
| 25215 | 3 x 5 m      | 8  |
| 25220 | 4 x 5 m      | 8  |
| 25224 | 4 x 6 m      | 8  |
| 25230 | 5 x 6 m      | 8  |

| Nu.   | specificație |   |
|-------|--------------|---|
| 25240 | 5 x 8 m      | 4 |
| 25248 | 6 x 8 m      | 3 |
| 25260 | 6 x 10 m     | 3 |
| 25296 | 8 x 12 m     | 2 |
| 25350 | 10 x 15 m    | 1 |



PE PRELATE

· albastru



| Nu.   | specificație |    |
|-------|--------------|----|
| 25369 | 2 x 2 m      | 50 |
| 25370 | 2 x 3 m      | 20 |
| 25371 | 3 x 4 m      | 10 |
| 25372 | 3 x 5 m      | 10 |
| 25373 | 4 x 5 m      | 10 |

| Nu.   | specificație |   |
|-------|--------------|---|
| 25374 | 4 x 6 m      | 5 |
| 25376 | 5 x 8 m      | 5 |
| 25378 | 6 x 10 m     | 2 |
| 25379 | 8 x 12 m     | 2 |
| 25380 | 10 x 15 m    | 2 |

PE PRELATE STANDARD

· albastru-argintiu

70 g/m<sup>2</sup>



| Nu.   | specificație |    |
|-------|--------------|----|
| 25155 | 2 x 2 m      | 50 |
| 25006 | 2 x 3 m      | 50 |
| 25009 | 3 x 3 m      | 35 |
| 25012 | 3 x 4 m      | 20 |
| 25015 | 3 x 5 m      | 10 |
| 25016 | 4 x 4 m      | 10 |
| 25020 | 4 x 5 m      | 10 |
| 25024 | 4 x 6 m      | 10 |

| Nu.   | specificație |    |
|-------|--------------|----|
| 25025 | 5 x 5 m      | 10 |
| 25030 | 5 x 6 m      | 10 |
| 25040 | 5 x 8 m      | 5  |
| 25048 | 6 x 8 m      | 5  |
| 25060 | 6 x 10 m     | 5  |
| 25096 | 8 x 12 m     | 2  |
| 25150 | 10 x 15 m    | 2  |
| 25153 | 15 x 20 m    | 1  |

PE PRELATE STANDARD

· verde

70 g/m<sup>2</sup>



| Nu.   | specificație |    |
|-------|--------------|----|
| 25179 | 2 x 2 m      | 50 |
| 25180 | 2 x 3 m      | 50 |
| 25195 | 2 x 8 m      | 20 |
| 25181 | 3 x 4 m      | 20 |
| 25182 | 3 x 5 m      | 10 |
| 25183 | 4 x 5 m      | 10 |

| Nu.   | specificație |    |
|-------|--------------|----|
| 25184 | 4 x 6 m      | 10 |
| 25186 | 5 x 8 m      | 5  |
| 25188 | 6 x 10 m     | 5  |
| 25189 | 8 x 12 m     | 2  |
| 25190 | 10 x 15 m    | 2  |

PE PRELATE PROFI

· verde-verde

200 g/m<sup>2</sup>



| Nu.   | specificație |    |
|-------|--------------|----|
| 25160 | 2 x 3 m      | 15 |
| 25171 | 2 x 8 m      | 1  |
| 25162 | 3 x 5 m      | 5  |
| 25163 | 4 x 5 m      | 4  |

| Nu.   | specificație |   |
|-------|--------------|---|
| 25164 | 4 x 6 m      | 3 |
| 25167 | 6 x 8 m      | 2 |
| 25169 | 8 x 12 m     | 1 |
| 25170 | 10 x 15 m    | 1 |

PE PRELATE

· kék-ezüst/ albastru-argintiu

120 g/m<sup>2</sup>



| Nu.   | specificație |    |
|-------|--------------|----|
| 25003 | Ø 3,6 m      | 15 |
| 25004 | Ø 4,5 m      | 5  |
| 25005 | Ø 5,5 m      | 4  |
| 25002 | Ø 6,5 m      | 3  |



ÎNȚINĂTOR PENTRU PRELATE

4x

| Nu.   | specificație |   |
|-------|--------------|---|
| 25400 | 20 cm        | 1 |

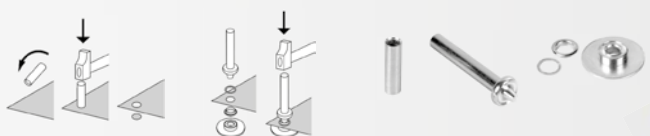

APLICATOR + CAPSE PENTRU PRELATE PE

| Nu.   | specificație                           |   |
|-------|--|---|
| 25410 | applicator of eyelet + 25 ok   eyelets | 1 |



CAPSE PENTRU PRELATE PE

10x

| Nu.   | specificație |   |
|-------|--------------|---|
| 25001 |              | 1 |





## SCARA RABATABILA TELESCOPICA

· max. sarcină 150 kg



| Nu.   | specificație |               |
|-------|--------------|---------------|
| 48415 | 1,9 / 3,8 m  | 6/12 partiții |

## SCARA TELESCOPICA

· max. sarcină 150 kg



| Nu.   | specificație |             |
|-------|--------------|-------------|
| 48410 | 3,2 m        | 11 partiții |
| 48411 | 3,8 m        | 13 partiții |

## PLATFORMĂ DE LUCRU PLIABILĂ

· max. sarcină 150 kg

ALU

| Nu.   | specificație |
|-------|--------------|
| 48420 |              |



NEW

|       |             |             |       |       |       |
|-------|-------------|-------------|-------|-------|-------|
|       |             |             |       |       |       |
| 2.75m | H L         | H L         | 1.73m | 0.93m | 0.99m |
|       | 1.60m 1.14m | 1.69m 1.32m |       |       |       |

## SCHELĂ MICĂ

KG  
13,6

· max 150 kg

| Nu.   | specificație |
|-------|--------------|
| 37660 |              |





CAPRA AJUSTABILA



| Nu.   | specificatie                 |   |
|-------|------------------------------|---|
| 37545 | 140 cm, inaltime 98 - 165 cm | 1 |
| 37546 | 120 cm, inaltime 98 - 165 cm | 1 |



POPI COFRAJ

· 48449 colivie pentru recuzite reglabile



| Nu.   | specificatie |   |
|-------|--------------|---|
| 48452 | 160 - 290 cm | 1 |
| 48453 | 180 - 320 cm | 1 |
| 48454 | 200 - 360 cm | 1 |
| 48455 | 250 - 440 cm | 1 |
| 48456 | 260 - 380 cm | 1 |
| 48457 | 220 - 400 cm | 1 |

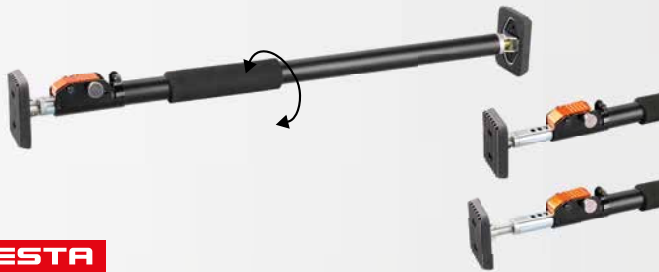

FESTA

SUPPORTING POLE

· max. sarcină 40 kg

| Nu.   | specificatie |   |  |
|-------|--------------|---|--|
| 52060 | 66 - 115 cm  | 1 |  |
| 52065 | 160 - 290 cm | 1 |  |



SUPPORTING POLE

| Nu.   | specificatie |   |  |
|-------|--------------|---|--|
| 52050 | 50 - 115 cm  | 1 |  |
| 52055 | 115 - 290 cm | 1 |  |

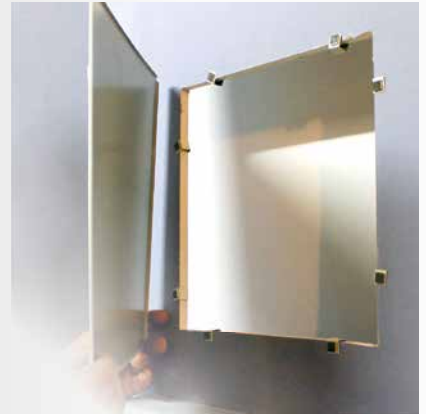

USI REVIZIE MAGNETIC

|  | Nu.   | specificatie |   |
|--|-------|--------------|---|
|  | 82100 | 10 - 21 cm   | 1 |
|  | 82101 | 20 - 31 cm   | 1 |
|  | 82102 | 30 - 41 cm   | 1 |
|  | 82103 | 40 - 51 cm   | 1 |
|  | 82104 | 50 - 58 cm   | 1 |



USĂ DE COȘ DIN TABLĂ



| Nu.   | specificatie |   |
|-------|--------------|---|
| 65062 |              | 1 |



USĂ DE COȘ DIN TABLĂ



| Nu.   | specificatie |   |
|-------|--------------|---|
| 65063 | gri          | 1 |
| 65064 | alb          | 1 |



USĂ DE COȘ DIN TABLĂ



| Nu.   | specificatie |   |
|-------|--------------|---|
| 65065 |              | 1 |

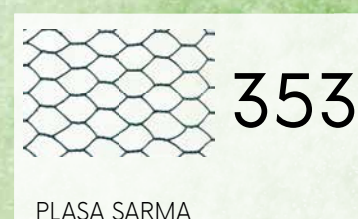
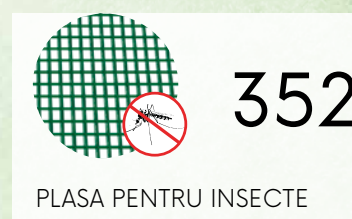
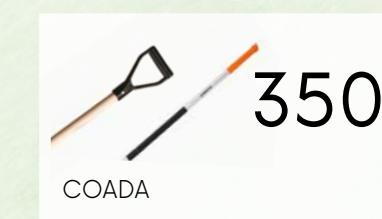
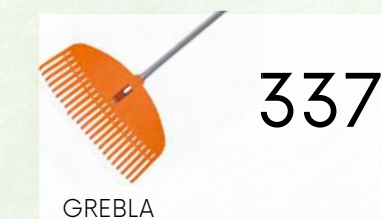



INSTRUMENTE DE  
GRADINA I SCRIMA

308 - 359





### FOARFECA PENTRU CRENGI



| Nu.   | specificație     |    |
|-------|------------------|----|
| 45020 | 205 mm           | 10 |
| 44980 | Arcul de rezervă | 1  |



### FOARFECA PENTRU CRENGI



| Nu.   | specificație     |    |
|-------|------------------|----|
| 45023 | 205 mm           | 10 |
| 44980 | Arcul de rezervă | 1  |



### FOARFECA PENTRU CRENGI



| Nu.   | specificație     |    |
|-------|------------------|----|
| 45063 | 215 mm           | 10 |
| 44981 | Arcul de rezervă | 1  |



### FOARFECA PENTRU CRENGI



| Nu.   | specificație     |    |
|-------|------------------|----|
| 44972 | 215 mm           | 10 |
| 44981 | Arcul de rezervă | 1  |



### FOARFECA PENTRU CRENGI

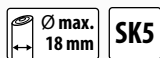

| Nu.   | specificație     |    |
|-------|------------------|----|
| 45099 | 190 mm           | 10 |
| 44983 | Arcul de rezervă | 1  |



### FOARFECA PENTRU CRENGI

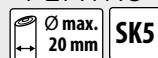

| Nu.   | specificație     |    |
|-------|------------------|----|
| 45098 | 220 mm           | 10 |
| 44983 | Arcul de rezervă | 1  |



### FOARFECA PENTRU CRENGI



| Nu.   | specificație     |    |
|-------|------------------|----|
| 45095 | 200 mm           | 10 |
| 44982 | Arcul de rezervă | 1  |



### FOARFECA PENTRU CRENGI

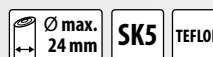

| Nu.   | specificație     |   |
|-------|------------------|---|
| 45096 | 220 mm           | 6 |
| 44982 | Arcul de rezervă | 1 |







FOARFECA PENTRU CRENGI



INOX max. mm INOX

| Nu.   | specificație |    |
|-------|--------------|----|
| 45089 | 160 mm       | 10 |



FOARFECA PENTRU CRENGI



SK5 TEFLON SK5 TEFLON

| Nu.   | specificație     |    |
|-------|------------------|----|
| 45097 | 210 mm           | 10 |
| 44981 | Arcul de rezervă | 1  |



FOARFECA PENTRU CRENGI



INOX max. 10 mm

| Nu.   | specificație |    |
|-------|--------------|----|
| 45088 | 160 mm       | 10 |



FOARFECA PENTRU CRENGI CU MANER TELESCOPIC

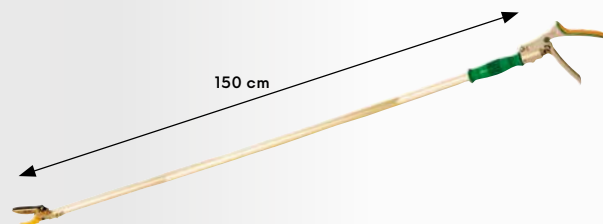

max. 12 mm

| Nu.   | specificație |    |
|-------|--------------|----|
| 45017 |              | 10 |



ARC REZERVA



| Nu.   | noyze                      |   |
|-------|----------------------------|---|
| 44981 | 45021, 45025, 45063, 45097 | 1 |
| 44980 | 45020, 45023               | 1 |
| 44983 | 45098, 45099               | 1 |
| 44982 | 45027, 45095, 45096        | 1 |
| 44984 | 45110, 45014, 45026        | 1 |
| 44985 | 45018                      | 1 |



SPARE LAMĂ



• pentru 45095, 45027

| Nu.   | specificație |    |
|-------|--------------|----|
| 45094 |              | 20 |



FOARFECA LUNGA PENTRU CRENGI, ROTUNJITA



max. 45mm SK5 TEFLON

| Nu.   | specificație |    |
|-------|--------------|----|
| 44991 | 76 cm        | 12 |



FOARFECA LUNGA PENTRU CRENGI, ROTUNJITA



max. 45mm SK5 TEFLON

| Nu.   | specificație |    |
|-------|--------------|----|
| 44992 | 70 - 103 cm  | 10 |



### FOARFECA LUNGA PENTRU CRENGI, ROTUNJITA

TEFLON



| Nu.   | specificație   |    |
|-------|----------------|----|
| 44996 | 61 cm, ondulat | 12 |



### FOARFECA LUNGA PENTRU CRENGI, ROTUNJITA

TEFLON



| Nu.   | specificație |    |
|-------|--------------|----|
| 44997 | 61 cm, drept | 12 |



### FOARFECA PENTRU IARBA, INTOARCERE 360°



| Nu.   | specificație |   |
|-------|--------------|---|
| 44998 |              | 6 |



### ASCUTITOR PENTRU CUȚITE ȘI FOARFECEI 6 V 1



| Nu.   | specificație |    |
|-------|--------------|----|
| 45068 |              | 10 |



### ASCUTITOR PENTRU CUȚITE ȘI FOARFECEI



| Nu.   | specificație |    |
|-------|--------------|----|
| 45048 |              | 20 |

FESTA

### FOARFECA PENTRU CRENGI

nylon coada



| Nu.   | specificație |   |
|-------|--------------|---|
| 45021 | 210 mm       | 6 |

### FOARFECA PENTRU CRENGI



| Nu.   | specificație |    |
|-------|--------------|----|
| 45019 | 210 mm       | 10 |



FESTA

### FOARFECA



| Nu.   | specificație     |    |
|-------|------------------|----|
| 45010 | 190 mm           | 12 |
| 44984 | Arcul de rezervă | 1  |

### FOARFECA



| Nu.   | specificație     |    |
|-------|------------------|----|
| 45014 | 190 mm           | 12 |
| 44984 | Arcul de rezervă | 1  |

### FOARFECA



| Nu.   | specificație     |    |
|-------|------------------|----|
| 45026 | 150 mm           | 12 |
| 44985 | Arcul de rezervă | 1  |

### FOARFECA PENTRU CRENGI FORJATA

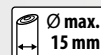

| Nu.   | specificație               |    |
|-------|----------------------------|----|
| 45018 | 210 mm fém cu vârf metalic | 10 |

FOARFECA  
PENTRU CRENGI

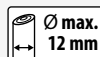

ALU



| Nu.   | specificatie |
|-------|--------------|
| 45025 | 200 mm       |



FOARFECA  
PENTRU CRENGI



INOX



| Nu.   | specificatie |
|-------|--------------|
| 44970 | 210 mm       |



FOARFECA  
PENTRU  
CRENGI

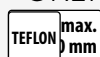

TEFLON



| Nu.   | specificatie |
|-------|--------------|
| 45027 | 200 mm       |



FOARFECA  
PENTRU CRENGI



INOX

ALU



| Nu.   | specificatie |
|-------|--------------|
| 45029 | 200 mm       |



FOARFECA  
PENTRU CRENGI

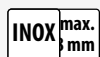

INOX



| Nu.   | specificatie |
|-------|--------------|
| 44971 | 160 mm       |



FOARFECA  
PENTRU CRENGI



INOX



| Nu.   | specificatie |
|-------|--------------|
| 45016 | 180 mm       |



FOARFECA  
DREAPTA



INOX



| Nu.   | specificatie  |
|-------|---------------|
| 45015 | 190 mm, drept |



TOC PENTRU  
FOARFECI CRENGI



| Nu.   | specificatie |
|-------|--------------|
| 37317 |              |



FOARFECA  
PENTRU IARBA



TEFLON



| Nu.   | specificatie |
|-------|--------------|
| 45011 | 300 mm       |



FOARFECA  
PENTRU IARBA,  
INTOARCERE 180°



| Nu.   | specificatie         |
|-------|----------------------|
| 45012 | 370 mm, turning 180° |



FOARFECA

· nylon coada



TEFLON

NYLON



| Nu.   | specificatie  |
|-------|---------------|
| 44999 | 540 mm, rundă |



**FESTA**

FOARFECA LUNGA PENTRU CRENGI, ROTUNJITA



| Nu.   | specificație  |   |
|-------|---------------|---|
| 45000 | 750 mm, rundă | 6 |

**FESTA**

FOARFECA LUNGA PENTRU CRENGI, ROTUNJITA

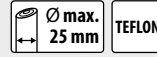

| Nu.   | specificație  |   |
|-------|---------------|---|
| 45001 | 710 mm, rundă | 6 |

**FESTA**

FOARFECA LUNGA PENTRU CRENGI, ROTUNJITA

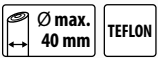

| Nu.   | specificație       |    |
|-------|--------------------|----|
| 45002 | 750 mm, cu clichet | 12 |

FOARFECA LUNGA PENTRU CRENGI, ROTUNJITA



| Nu.   | specificație            |   |
|-------|-------------------------|---|
| 45003 | 660-900 mm, telescopică | 6 |

**FESTA**

FOARFECA

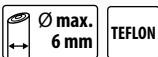

| Nu.   | specificație          |   |
|-------|-----------------------|---|
| 45005 | 580   230 mm, ondulat | 6 |

**FESTA**

FOARFECA



| Nu.   | specificație        |   |
|-------|---------------------|---|
| 45006 | 580   230 mm, drept | 6 |

**FESTA**

FOARFECA



| Nu.   | specificație              |   |
|-------|---------------------------|---|
| 45007 | 670-870   230 mm, ondulat | 6 |

FOARFECA



| Nu.   | specificație |    |
|-------|--------------|----|
| 44995 | 440   160 mm | 12 |

FOARFECA

| Nu.   | specificație          |   |
|-------|-----------------------|---|
| 45009 | 500   190 mm, ondulat | 6 |



FOARFECA

| Nu.   | specificație        |   |
|-------|---------------------|---|
| 45008 | 500   190 mm, drept | 6 |



SE CERĂ

| Nu.   | specificație |   |
|-------|--------------|---|
| 45490 | 450 mm       | 1 |



**FESTA**  
MACETA



TEFLON

| Nu.   | specificatie |   |
|-------|--------------|---|
| 45069 | 440 mm       | 6 |

**FESTA**  
MACETA



TEFLON

| Nu.   | specificatie |   |
|-------|--------------|---|
| 44950 | 490 mm       | 4 |

MACETA

INOX

| Nu.   | specificatie |    |
|-------|--------------|----|
| 45083 | 430 mm       | 12 |
| 45084 | 600 mm       | 6  |



MACETA

mâner realizat din lemn de frasin

| Nu.   | specificatie |    |
|-------|--------------|----|
| 45081 | 510 mm       | 36 |
| 45082 | 710 mm       | 36 |



**FESTA**  
FERASTRAU PLIANT

3 randuri de dinti tratati termic

| Nu.   | specificatie  |    |
|-------|---------------|----|
| 45061 | 150 mm pliabi | 12 |



**FESTA**  
FERASTRAU PLIANT

3 randuri de dinti tratati termic

| Nu.   | specificatie |   |
|-------|--------------|---|
| 45060 | 180 mm       | 6 |



**FESTA**  
FERASTRAU PLIANT

3 randuri de dinti tratati termic

| Nu.   | specificatie      |    |
|-------|-------------------|----|
| 45062 | 260 mm cu carcasa | 24 |



**FESTA**  
FERASTRAU PENTRU CRENGI

3 randuri de dinti tratati termic

| Nu.   | specificatie |    |
|-------|--------------|----|
| 24152 | 350 mm 7 tpi | 12 |



**FESTA**  
FERASTRAU TELESCOPIC

3 randuri de dinti tratati termic

| Nu.   | specificatie |   |
|-------|--------------|---|
| 45033 | 230 - 490 mm | 1 |



FERASTRAU TELESCOPIC

| Nu.   | specificatie                          |   |
|-------|---------------------------------------|---|
| 45030 | ferastrau 30 cm pol telescopic 240 cm | 6 |
| 45031 | ferastrau 30 cm                       | 6 |



FERASTRAU TELESCOPIC

| Nu.   | specificatie          |   |
|-------|-----------------------|---|
| 45032 | metal, fara ferastrau | 6 |





**FESTA**

**FESTA**

TOPOR

**DIN 5131** **DIN 7294**

- mâner de frasin
- circulara



| Nu.   | specificație |   | Nu.   | specificație |   |
|-------|--------------|---|-------|--------------|---|
| 19380 | 600 g        | 1 | 19384 | 1400 g       | 1 |
| 19381 | 800 g        | 1 | 19385 | 1600 g       | 1 |
| 19382 | 1000 g       | 1 | 19387 | 2000 g       | 1 |
| 19383 | 1250 g       | 1 |       |              |   |

**FESTA**

TOPOR  
TAMPLARI

- mâner de frasin



| Nu.   | specificație |    |
|-------|--------------|----|
| 19340 | 700 g        | 22 |

**FESTA**

TOPOR

- mâner de frasin
- circulara

| <b>DIN 5129</b> | Nu.   | specificație |   |
|-----------------|-------|--------------|---|
|                 | 19389 | 3000 g       | 1 |
|                 | 19388 | 4000 g       | 1 |



**FESTA**

TOPOR

- mâner de frasin
- circulara

| <b>DIN 7294</b> |  | Nu.   | specificație |   |
|-----------------|--|-------|--------------|---|
|                 |  | 19391 | 2000 g       | 1 |



**FESTA**

TOPOR MANER COADA FIBRA

- fiberglass

| C.p.  | specificație |    |
|-------|--------------|----|
| 19326 | 600 g        | 6  |
| 19328 | 800 g        | 24 |
| 19330 | 1000 g       | 12 |
| 19332 | 1250 g       | 8  |
| 19333 | 1500 g       | 6  |
| 19335 | 1600 g       | 6  |
| 19337 | 2000 g       | 6  |



**FESTA**

TOPOR DESPICAT  
COADA FIBRA

- fiberglass

| C.p.  | specificație |   |
|-------|--------------|---|
| 19392 | 1000 g       | 6 |



**FESTA**

TOPOR CAMP  
FIBERGLASS

- fiberglass

| C.p.  | specificație |   |
|-------|--------------|---|
| 19301 | 500 g        | 6 |



**FESTA**

TOPOR DESPICAT COADA FIBRA

- fiberglass

| Nu.   | specificație |   |
|-------|--------------|---|
| 19390 | 2000 g       | 6 |





**FESTA**

**TOPOR**

· fiberglass

| Nu.   | specificatie |   |
|-------|--------------|---|
| 19370 | 3000 g       | 4 |
| 19371 | 4000 g       | 4 |



**COADA LEMN  
TOPOR**



| Č.p.  | specifikace | pro sekeru   |    |
|-------|-------------|--------------|----|
| 61340 | 36 cm       | 19380        | 10 |
| 61341 | 40 cm       | 19381, 19340 | 10 |
| 61342 | 50 cm       | 19382        | 10 |
| 61343 | 70 cm       | 19383, 19384 | 10 |
| 61344 | 80 cm       | 19385, 19391 | 10 |
| 61345 | 90 cm       | 19387        | 10 |
| 61346 | 90 cm       | 19388, 19389 | 10 |

**TOPOR**

| Č.p.  | specifikace |    |
|-------|-------------|----|
| 19306 | 600 g       | 24 |
| 19308 | 800 g       | 24 |
| 19310 | 1000 g      | 24 |
| 19312 | 1250 g      | 12 |
| 19314 | 1500 g      | 12 |



**DALTA PANA**

| Nu.   | specificatie            |    |
|-------|-------------------------|----|
| 19397 | 2000 g 55 x 210 x 45 mm | 10 |
| 19465 | 2500 g 65 x 230 x 45 mm | 10 |



**DALTA PANA**



| Nu.   | specificatie     |   |
|-------|------------------|---|
| 19462 | 175 x 65 x 20 mm | 1 |
| 19463 | 230 x 70 x 30 mm | 1 |
| 19464 | 240 x 75 x 40 mm | 1 |



**DALTA PANA**

| Nu.   | specificatie            |   |
|-------|-------------------------|---|
| 19394 | 1000 g 35 x 180 x 40 mm | 6 |
| 19395 | 2000 g 40 x 255 x 55 mm | 6 |
| 19396 | 2500 g 40 x 260 x 55 mm | 8 |



**MANDRIN DE DESPICARE SDS+**

**SDS+**

| Nu.   | Specificatie  |    |
|-------|---------------|----|
| 19393 | Ø 32 x 132 mm | 10 |
| 19374 | Ø 42 x 145 mm | 10 |



**DALTA PANA**

| Nu.   | specificatie       |    |
|-------|--------------------|----|
| 19469 | 2500 g 165 x 87 mm | 10 |

### LOPATA LATA



INOX

| Nu.   | specificație |    |
|-------|--------------|----|
| 45056 | 360 mm       | 12 |

### LOPATA INGUSTA



INOX

| Nu.   | specificație |    |
|-------|--------------|----|
| 45057 | 360 mm       | 12 |

### SAPA



INOX

| Nu.   | specificație |    |
|-------|--------------|----|
| 45058 | 270 mm       | 12 |

### PLIVITOR



INOX

| Nu.   | specificație |    |
|-------|--------------|----|
| 45059 | 360 mm       | 12 |

### LOPATA LATA



NYLON

| Nu.   | specificație |   |
|-------|--------------|---|
| 45065 | 280 mm       | 1 |

### LOPATA INGUSTA



NYLON

| Nu.   | specificație |   |
|-------|--------------|---|
| 45066 | 310 mm       | 1 |

### CULTIVATOR



NYLON

| Nu.   | specificație |   |
|-------|--------------|---|
| 45067 | 290 mm       | 1 |

### SET UNELTE PENTRU GRADINA



HOBBY 4x

| Nu.   | specificație |    |
|-------|--------------|----|
| 45035 | 240 mm       | 35 |

### SAPA ASCUTITA



| Nu.   | specificație | lungime mânerului |       |
|-------|--------------|-------------------|-------|
| 61294 | 140 mm       | 27 cm             | MOQ 3 |
| 61221 | mâner        | 27 cm             | 1     |

### SAPA ASCUTITA



| Nu.   | specificație | lungime mânerului |       |
|-------|--------------|-------------------|-------|
| 61295 | 140 mm       | 27 cm             | MOQ 3 |
| 61221 | mâner        | 27 cm             | 1     |

### SAPA ASCUTITA



| Nu.   | specificație | lungime mânerului |       |
|-------|--------------|-------------------|-------|
| 61296 | 175 mm       | 27 cm             | MOQ 3 |
| 61221 | mâner        | 27 cm             | 1     |

### SAPA ASCUTITA



| Nu.   | specificație | lungime mânerului |       |
|-------|--------------|-------------------|-------|
| 61297 |              | 27 cm             | MOQ 3 |
| 61221 | mâner        | 27 cm             | 1     |





LOPATĂ PLIANTĂ

carcasă

| Nu.   | specificație |   |
|-------|--------------|---|
| 61085 | 410 mm       | 6 |



PLANTATOR CU MANER

INOX

| Nu.   | specificație |    |
|-------|--------------|----|
| 45040 | 230 mm       | 60 |



TARUS PENTRU PLANTAT "T"

| Nu.   | specificație |    |
|-------|--------------|----|
| 45038 | 280 mm       | 60 |



CUȚIT PENTRU BURUIENI

| Nu.   | specificație |   |
|-------|--------------|---|
| 45079 | 200 mm       | 1 |



CUȚIT PENTRU BURUIENI

| Nu.   | specificație |   |
|-------|--------------|---|
| 45080 | 200 mm „L”   | 1 |



SACULET PENTRU CULES FRUCTE



| Nu.   | specificație |    |
|-------|--------------|----|
| 45041 |              | 75 |



SACULET PENTRU CULES FRUCTE

| Nu.   | specificație             |    |
|-------|--------------------------|----|
| 45039 |                          | 50 |
| 45034 | 170 - 300 cm, telescopic | 5  |



DISPOZITIV PENTRU SMULS BURUIENI

| Nu.   | specificație |    |
|-------|--------------|----|
| 44955 | 950 mm       | 16 |



DISCUIȚOR CU TEPI

| Nu.   | specificație |    |
|-------|--------------|----|
| 45042 | 160 x 132 cm | 12 |



DISCUIȚOR CU TEPI

| Nu.   | specificație |    |
|-------|--------------|----|
| 44053 |              | 12 |
| 61251 | 160 cm mâner | 1  |



REMORCA GRADINARIT

| specificație |        |
|--------------|--------|
| înălțime:    | 111 cm |
| larg:        | 55 cm  |
| volum:       | 12 l   |

| Nu.   | specificație |   |
|-------|--------------|---|
| 45085 | 12 l         | 1 |

**FESTA**

**PIATRA DE ASCUTIT  
16v1**



|  |            |  |
|--|------------|--|
|  | 30° Anvil  |  |
|  | 45° Anvil  |  |
|  | 50° Anvil  |  |
|  | 23° Bypass |  |
|  | 35° Bypass |  |
|  | 65° Bypass |  |
|  | Debur Tool |  |



| Nu.   | specificație |   |
|-------|--------------|---|
| 45073 |              | 1 |



**PIATRA DE ASCUTIT**

| Nu.   | specificație |    |
|-------|--------------|----|
| 45068 |              | 10 |



**UNEALTA ASCUTIT  
CUTITE FOARFECI**

| Nu.   | specificație |    |
|-------|--------------|----|
| 45048 |              | 20 |



**PIATRA DE ASCUTIT**

| Nu.   | specificație |     |
|-------|--------------|-----|
| 45046 | 205 x 15 mm  | 100 |



**PIATRA DE ASCUTIT**

| Nu.   | specificație     |    |
|-------|------------------|----|
| 45370 | 250 x 33 x 18 mm | 20 |



**PIATRA DE ASCUTIT**

| Nu.   | specificație     |    |
|-------|------------------|----|
| 45045 | 150 x 50 x 30 mm | 10 |



**PIATRA DE ASCUTIT**

| Nu.   | specificație |    |
|-------|--------------|----|
| 16991 |              | 20 |



**PIATRA DE ASCUTIT**

| Nu.   | specificație |    |
|-------|--------------|----|
| 16990 | Ø 50 mm      | 50 |





FIR DE TAIAT GAZON



| Nu.   |   | specificație   |   |
|-------|---|----------------|---|
| 45530 | ■ | 2 mm x 15 m    | 1 |
| 45531 | ■ | 2,4 mm x 15 m  | 1 |
| 45532 | ■ | 3 mm x 15 m    | 1 |
| 45533 | ■ | 3,15 mm x 15 m | 1 |
| 45534 | ■ | 4 mm x 15 m    | 1 |



FIR DE TAIAT GAZON

| Nu.   |   | specificație   |    |
|-------|---|----------------|----|
| 45520 | ● | 2 mm x 162 m   | 10 |
| 45521 | ● | 2,4 mm x 112 m | 10 |
| 45528 | ● | 2,7 mm x 90 m  | 10 |
| 45522 | ● | 3 mm x 72 m    | 10 |
| 45525 | ★ | 2 mm x 162 m   | 10 |
| 45526 | ★ | 2,4 mm x 112 m | 10 |
| 45529 | ★ | 2,7 mm x 90 m  | 10 |
| 45527 | ★ | 3 mm x 72 m    | 10 |

FIR DE TAIAT GAZON



| Nu.   |   | specificație  |    |
|-------|---|---------------|----|
| 45500 | ● | 1,3 mm x 15 m | 30 |
| 45502 | ★ | 1,3 mm x 15 m | 30 |
| 45503 | ● | 1,6 mm x 15 m | 20 |
| 45505 | ★ | 1,6 mm x 15 m | 20 |
| 45506 | ● | 2 mm x 15 m   | 12 |
| 45508 | ★ | 2 mm x 15 m   | 12 |
| 45517 | ■ | 2 mm x 15 m   | 10 |
| 45509 | ● | 2,4 mm x 15 m | 12 |
| 45511 | ★ | 2,4 mm x 15 m | 12 |
| 45512 | ■ | 2,4 mm x 15 m | 12 |
| 45518 | ■ | 2,4 mm x 15 m | 10 |
| 45523 | ● | 2,7 mm x 15 m | 10 |
| 45524 | ★ | 2,7 mm x 15 m | 10 |
| 45513 | ● | 3 mm x 15 m   | 10 |
| 45515 | ★ | 3 mm x 15 m   | 10 |
| 45516 | ■ | 3 mm x 15 m   | 10 |
| 45519 | ■ | 3 mm x 15 m   | 10 |



TESATURA SINTETICA



17 g/m<sup>2</sup>

| Nu.   | specificație |               |
|-------|--------------|---------------|
| 45540 | 1,6 x 5 m    | 40            |
| 45541 | 1,6 x 10 m   | 40            |
| 45542 | 1,6 x 50 m   | într-un rol 1 |
| 45543 | 1,6 x 100 m  | într-un rol 1 |



50 g/m<sup>2</sup>

| Nu.   | specificație |               |
|-------|--------------|---------------|
| 45550 | 1,6 x 5 m    | 50            |
| 45551 | 1,6 x 10 m   | 20            |
| 45564 | 3,2 x 10 m   | 20            |
| 45552 | 1,6 x 50 m   | într-un rol 1 |
| 45553 | 1,6 x 100 m  | într-un rol 1 |
| 45562 | 3,2 x 50 m   | într-un rol 1 |
| 45563 | 3,2 x 100 m  | într-un rol 1 |

TESATURA SINTETICA



50 g/m<sup>2</sup>

| Nu.   | specificație |               |
|-------|--------------|---------------|
| 45556 | 1,6 x 5 m    | 50            |
| 45557 | 1,6 x 10 m   | 20            |
| 45565 | 3,2 x 10 m   | 20            |
| 45558 | 1,6 x 50 m   | într-un rol 1 |
| 45559 | 1,6 x 100 m  | într-un rol 1 |

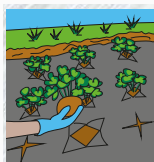

## TESATURA SINTETICA

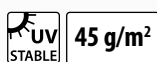

| Nu.   | specificatie |    |
|-------|--------------|----|
| 45535 | 1,6 x 5 m    | 18 |



## ȘTIȚ DE ANCORARE PENTRU PRINDEREA

10x

| Nu.   | specificatie |   |
|-------|--------------|---|
| 45555 | 11,5 cm      | 1 |

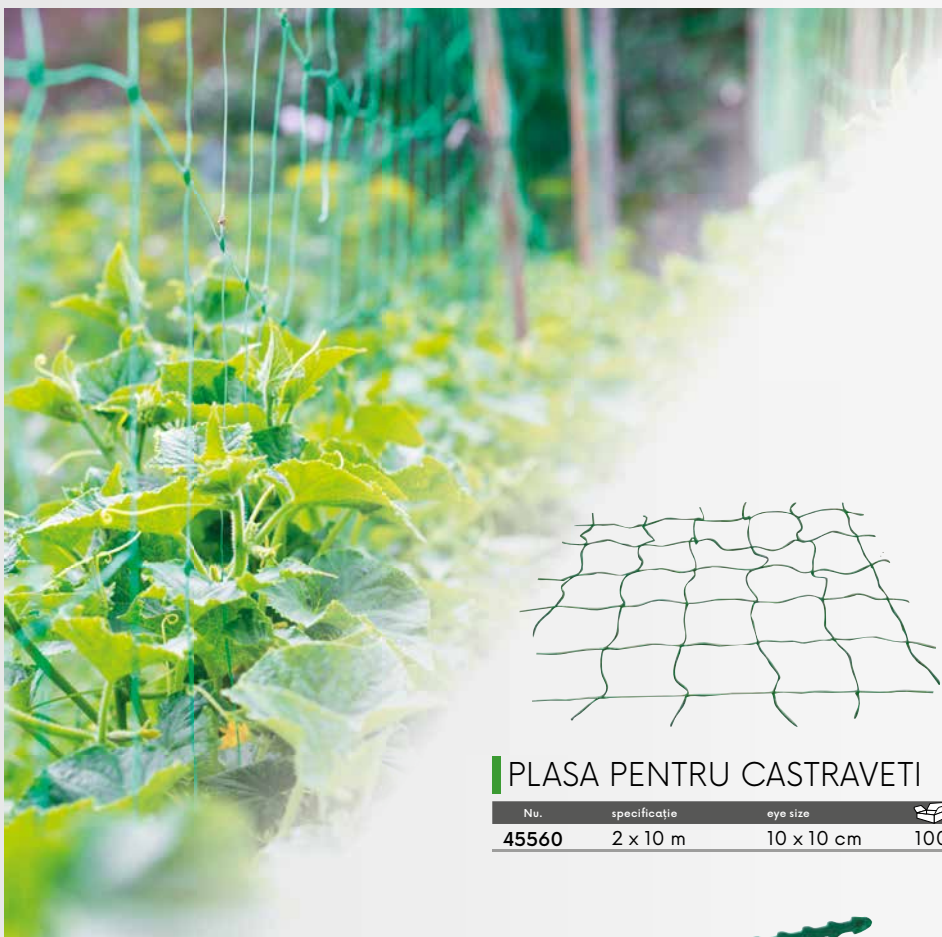

## PLASA PENTRU CASTRAVETI

| Nu.   | specificatie | eye size   |     |
|-------|--------------|------------|-----|
| 45560 | 2 x 10 m     | 10 x 10 cm | 100 |

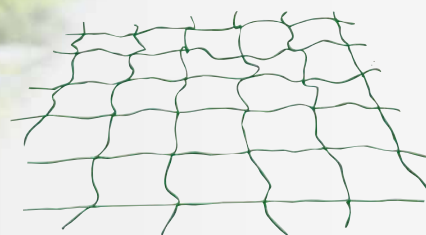

## TIJA FIBRA

| Nu.   | specificatie    |     |
|-------|-----------------|-----|
| 45036 | 180 cm Ø 7,9 mm | 100 |

## CLEME PLASTIC

50x

| Nu.   | specificatie |    |
|-------|--------------|----|
| 23840 |              | 20 |



## BAR ACOPERIT PLASTIC

| Nu.   | specificatie   |    | Nu.   | specificatie   |    | Nu.   | specificatie   |    |
|-------|----------------|----|-------|----------------|----|-------|----------------|----|
| 45650 | 90 cm Ø 8 mm   | 25 | 45655 | 150 cm Ø 11 mm | 25 | 45659 | 180 cm Ø 16 mm | 25 |
| 45651 | 120 cm Ø 8 mm  | 25 | 45656 | 180 cm Ø 11 mm | 25 | 45660 | 210 cm Ø 16 mm | 25 |
| 45652 | 150 cm Ø 8 mm  | 25 | 45661 | 210 cm Ø 11 mm | 25 | 45662 | 150 cm Ø 20 mm | 10 |
| 45653 | 90 cm Ø 11 mm  | 25 | 45657 | 120 cm Ø 16 mm | 25 | 45663 | 180 cm Ø 20 mm | 10 |
| 45654 | 120 cm Ø 11 mm | 25 | 45658 | 150 cm Ø 16 mm | 25 | 45664 | 210 cm Ø 20 mm | 10 |



## SPIRALE DE AGATARE PENTRU PLANTE

| Nu.   | specificatie    |                  |    |
|-------|-----------------|------------------|----|
| 44041 | 1,2 m, Ø 5,5 mm | komaxit - green  | 10 |
| 44042 | 1,5 m, Ø 6 mm   | komaxit - green  | 10 |
| 44043 | 1,8 m, Ø 6 mm   | komaxit - green  | 10 |
| 45049 | 1,8 m, Ø 7 mm   | komaxit - green  | 10 |
| 45044 | 1,8 m, Ø 7 mm   | komaxit - silver | 10 |
| 44050 | 2,2 m, Ø 7 mm   | komaxit - green  | 10 |

## COROBORAT PLASTIC

MOQ 10

| Nu.   | specificatie |    |
|-------|--------------|----|
| 45670 | 8 mm         | 10 |
| 45671 | 11 mm        | 10 |
| 45672 | 16 mm        | 10 |
| 45673 | 20 mm        | 10 |





BANDĂ CU SCAI



| Nu.   | specificație |   |
|-------|--------------|---|
| 45471 | 12 mm x 5 m  | 1 |



SARMA PENTRU GRADINA



| Nu.   | specificație |    |
|-------|--------------|----|
| 45043 | 30 m         | 30 |

SĂRMĂ LEGARE GUMATĂ



| Nu.   | specificație |    |
|-------|--------------|----|
| 23845 | 3 mm x 8 m   | 30 |
| 23846 | 4 mm x 6 m   | 30 |
| 23847 | 5 mm x 4 m   | 30 |



BENZI LEGARE

3x



| Nu.   | specificație      |    |
|-------|-------------------|----|
| 45472 | 3 cm x 3 m, 3 buc | 36 |



BENZI LEGARE



| Nu.   | specificație |    |
|-------|--------------|----|
| 45473 | 3 cm x 50 m  | 60 |



SUPORT TAIERE

| Nu.   | specificație   |    |
|-------|----------------|----|
| 45086 | 40 x 18 x 2 cm | 50 |



SCĂUNEL GRĂDINĂRIT, PLIANT

for sitting and upside down for kneeling



| Nu.   | specificație    |   |
|-------|-----------------|---|
| 45074 | 58 x 48 x 28 cm | 4 |



COS PLIABIL

| Nu.   | specificație    |    |
|-------|-----------------|----|
| 45093 | 40 x 25 x 23 cm | 10 |



GALEATA



| Nu.   | specificație |    |
|-------|--------------|----|
| 39192 | 26 l         | 20 |
| 39193 | 42 l         | 20 |



SAC COLECTOR

| Nu.   | specificație         |    |
|-------|----------------------|----|
| 45047 | 55 x 70 cm, 3 drăzda | 20 |



SAC COLECTOR

| Nu.   | specificație            |    |
|-------|-------------------------|----|
| 44960 | 200 l   60 x 60 x 55 cm | 50 |



**FESTA®**  
AQUATIC

**FESTA®**  
AQUATIC

**PISTOL DE STROPIT**

- 7 functions
- front trigger with lock
- effortless flow control



|       |              |    |
|-------|--------------|----|
| Nu.   | specificație |    |
| 45386 |              | 12 |

**FESTA®**  
AQUATIC

**PISTOL DE STROPIT**

- adjustable flowing
- front trigger with lock
- effortless flow control



|       |              |    |
|-------|--------------|----|
| Nu.   | specificație |    |
| 45388 |              | 12 |

**FESTA®**  
AQUATIC

**STROPITOARE**

- adjustable flowing



|       |              |    |
|-------|--------------|----|
| Nu.   | specificație |    |
| 45389 |              | 24 |



**FESTA®**  
AQUATIC

**SET CU PISTOL DE STROPIT**

- adjustable flowing



|       |              |    |
|-------|--------------|----|
| Nu.   | specificație |    |
| 45385 | 4 buc        | 12 |

**FESTA®**  
AQUATIC

**RACORD**



|      |              |    |
|------|--------------|----|
| Nu.  | specificație |    |
| 1/2" | 45390        | 24 |

**FESTA®**  
AQUATIC

**CONECTOR**



|      |              |    |
|------|--------------|----|
| Nu.  | specificație |    |
| 1/2" | 45392        | 24 |

**FESTA®**  
AQUATIC

**CONECTOR CU STOP**



|      |              |    |
|------|--------------|----|
| Nu.  | specificație |    |
| 1/2" | 45394        | 24 |

**FESTA®**  
AQUATIC

**RACORD**



|      |              |    |
|------|--------------|----|
| Nu.  | specificație |    |
| 3/4" | 45391        | 24 |

**FESTA®**  
AQUATIC

**CONECTOR**



|      |              |    |
|------|--------------|----|
| Nu.  | specificație |    |
| 3/4" | 45393        | 24 |

**FESTA®**  
AQUATIC

**CONECTOR CU STOP**



|      |              |    |
|------|--------------|----|
| Nu.  | specificație |    |
| 3/4" | 45395        | 24 |

**FESTA**  
AQUATIC

ADAPTOR CU FILET INTERIOR



| Nu.   | specificație |    |
|-------|--------------|----|
| 45396 |              | 24 |



NEW



**FESTA**  
AQUATIC

GRĂDINĂ FURTUN PROFI



| Nu.   | specificație |   |
|-------|--------------|---|
| 45372 | 1/2" 25 m    | 1 |
| 45373 | 1/2" 50 m    | 1 |
| 45374 | 3/4" 25 m    | 1 |
| 45375 | 3/4" 50 m    | 1 |
| 45376 | 1" 25 m      | 1 |
| 45377 | 1" 50 m      | 1 |



**FESTA**  
AQUATIC

ADAPTOR CU FILET INTERIOR



| Nu.   | specificație |    |
|-------|--------------|----|
| 45397 |              | 24 |



**FESTA**  
AQUATIC

STROPITOARE CU BALANSARE

· 19 nozzles with 8 switchable (on/off) spray nozzles



| Nu.   | specificație |   |
|-------|--------------|---|
| 45398 |              | 6 |

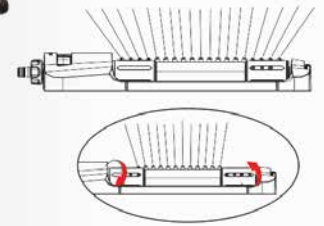

**FESTA**  
AQUATIC

STROPITOARE ROTATIVA 3 SENȘURI

· adjustable arms with nozzles



| Nu.   | specificație |    |
|-------|--------------|----|
| 45399 |              | 12 |



**FESTA**  
AQUATIC

TAP ADAPTOR

· adjustable flow control



| Nu.   | specificație |   |
|-------|--------------|---|
| 45400 |              | 6 |



**FESTA**  
AQUATIC

TAP ADAPTOR

· adjustable flow control



| Nu.   | specificație |   |
|-------|--------------|---|
| 45401 |              | 6 |



**ROSA**

**PISTOL DE STROPIT**

- 10 functions
- front trigger with lock



Nu.      specificatie  
**45124**      12

**ROSA**

**PISTOL DE STROPIT**

- 10 functions
- trigger with lock
- effortless flow control



Nu.      specificatie  
**45125**      12



**ROSA**

**Watering system**

**ROSA**

**PISTOL DE STROPIT**

- 7 functions
- trigger with lock



Nu.      specificatie  
**45126**      12

**ROSA**

**PISTOL DE STROPIT**

- 7 functions
- trigger with lock
- effortless flow control



Nu.      specificatie  
**45123**      metal 12

**ROSA**

**PISTOL DE STROPIT**

- 6 functions
- trigger with lock
- effortless flow control



Nu.      specificatie  
**45117**      12

**ROSA**

**PISTOL DE STROPIT**

- 6 functions
- trigger with lock
- effortless flow control



Nu.      specificatie  
**45118**      metal 12

**ROSA**

**PISTOL DE STROPIT**

- 5 functions
- trigger with lock
- effortless flow control



Nu.      specificatie  
**45110**      12

**ROSA**

**PISTOL DE STROPIT**

- pistol pulverizator
- effortless flow control



Nu.      specificatie  
**45116**      12



**ROSA**

**PISTOL DE STROPIT**

- metal head
- trigger with lock
- effortless flow control



|       |              |    |  |
|-------|--------------|----|--|
| Nu.   | specificație |    |  |
| 45120 |              | 12 |  |



**ROSA**

**PISTOL DE STROPIT**

- trigger with lock
- effortless flow control



|       |              |    |  |
|-------|--------------|----|--|
| Nu.   | specificație |    |  |
| 45115 |              | 12 |  |



**ROSA**

**PISTOL DE STROPIT**

- metal
- trigger with lock
- effortless flow control



|       |              |    |  |
|-------|--------------|----|--|
| Nu.   | specificație |    |  |
| 45122 | metal        | 12 |  |



**ROSA**

**PISTOL DE STROPIT SET**

- trigger with lock
- effortless flow control



2x

|       |                    |    |  |
|-------|--------------------|----|--|
| Nu.   | specificație       |    |  |
| 45114 | 1/2 hose connector | 12 |  |



**ROSA**

**PISTOL DE STROPIT**

- trigger with lock
- effortless flow control



|       |              |    |  |
|-------|--------------|----|--|
| Nu.   | specificație |    |  |
| 45111 |              | 12 |  |



**ROSA**

**PISTOL DE STROPIT SET**

- 6 functions
- trigger with lock
- effortless flow control



4x

|       |              |    |  |
|-------|--------------|----|--|
| Nu.   | specificație |    |  |
| 45181 |              | 12 |  |



**ROSA**

**STROPITOARE**

- adjustable flowing



|       |              |    |  |
|-------|--------------|----|--|
| Nu.   | specificație |    |  |
| 45214 |              | 48 |  |



**ROSA**

**STROPITOARE**

- stream lined
- clasic connection



|       |              |    |  |
|-------|--------------|----|--|
| Nu.   | specificație |    |  |
| 45112 |              | 32 |  |

**ROSA**

**STROPITOARE**

- adjustable flowing



|       |              |    |  |
|-------|--------------|----|--|
| Nu.   | specificație |    |  |
| 45113 |              | 60 |  |



**ROSA**

**SET CU PISTOL DE STROPIT**

- adjustable flowing



4x

|       |              |    |  |
|-------|--------------|----|--|
| Nu.   | specificație |    |  |
| 45180 |              | 12 |  |



**ROSA**  
RACORD

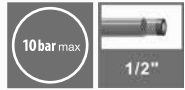

Nu. specificație 60

**ROSA**  
CONECTOR



Nu. specificație 60

**ROSA**  
CONECTOR  
CU STOP



Nu. specificație 60

**ROSA**  
RACORD



MOQ 20

Nu. specificație 45296 MOQ 20

**ROSA**  
CONECTOR



MOQ 20

Nu. specificație 45298 MOQ 20

**ROSA**  
CONECTOR  
CU STOP



MOQ 20

Nu. specificație 45294 MOQ 20

**ROSA**  
RACORD



Nu. specificație 45141 60

**ROSA**  
CONECTOR



Nu. specificație 45143 60

**ROSA**  
CONECTOR  
CU STOP



Nu. specificație 45139 60

**ROSA**  
RACORD



MOQ 20

Nu. specificație 45297 MOQ 20

**ROSA**  
CONECTOR



MOQ 20

Nu. specificație 45299 MOQ 20

**ROSA**  
CONECTOR  
CU STOP



MOQ 20

Nu. specificație 45295 MOQ 20

**ROSA**  
REDUCTOR FURTUN



Nu. specificație 45213 1/2" - 3/4" 60

**ROSA**  
REDUCTOR FURTUN



Nu. specificație 45216 1" 3/4" 48

**ROSA**  
RACORD



Nu. specificație 45218 1" 48

**ROSA**

ADAPTOR  
CU FILET  
INTERIOR



| Nu.   | specificație |    |
|-------|--------------|----|
| 45130 | 1/2" + 3/4"  | 60 |
| 45131 | 3/4" + 1"    | 60 |

**ROSA**

ADAPTER



| Nu.   | specificație |    |
|-------|--------------|----|
| 45217 |              | 48 |

**ROSA**

CONECTOR



| Nu.   | specificație |    |
|-------|--------------|----|
| 45219 |              | 48 |

**ROSA**

ADAPTOR CU FILET  
INTERIOR



MOQ  
20

| Nu.   | specificație |        |
|-------|--------------|--------|
| 45289 | 1/2" + 3/4"  | MOQ 20 |
| 45290 | 3/4" + 1"    | MOQ 20 |

**ROSA**

CONECTORI PENTRU FURTUN

2x



| Nu.   | specificație |    |
|-------|--------------|----|
| 45144 |              | 60 |

**ROSA**

CONECTOR  
CU ROBINET

· conector simplu cu robinet



| Nu.   | specificație |    |
|-------|--------------|----|
| 45135 |              | 60 |

**ROSA**

ADAPTOR CU FILET  
INTERIOR



| Nu.   | specificație |    |
|-------|--------------|----|
| 45133 |              | 60 |

**ROSA**

ADAPTOR CU FILET  
INTERIOR



| Nu.   | specificație |    |
|-------|--------------|----|
| 45132 |              | 60 |

**ROSA**

ADAPTOR CU FILET INTERIOR



| Nu.   | specificație |    |
|-------|--------------|----|
| 45136 |              | 60 |

**ROSA**

ADAPTOR



MOQ  
20

| Nu.   | specificație |        |
|-------|--------------|--------|
| 45292 |              | MOQ 20 |

**ROSA**

ADAPTOR CU FILET INTERIOR



MOQ  
20

| Nu.   | specificație |        |
|-------|--------------|--------|
| 45291 |              | MOQ 20 |

**ROSA**

ADAPTOR



MOQ  
20

| Nu.   | specificație |        |
|-------|--------------|--------|
| 45293 |              | MOQ 20 |

**ROSA**

ADAPTOR PENTRU 3 FURTUNURI



| Nu.   | specificație |    |
|-------|--------------|----|
| 45137 |              | 60 |

**ROSA**

ADAPTOR



| Nu.   | specificație |    |
|-------|--------------|----|
| 45215 |              | 48 |

**ROSA**

ADAPTOR PENTRU FURTUN



| Nu.   | specificație |    |
|-------|--------------|----|
| 45145 |              | 60 |

## ROSA

RACORD  
BIFURCAT PENTRU  
2 CUPLE RAPIDE

· adaptor cu robinet, conector pentru 2

0,7 bar min  
5,5 bar max

Nu. specificație

45134

12



3/4"

## ROSA

## CUTIE PREZENTARE

· sadrži

45113 15 szt. | kom  
45117 10 szt. | kom  
45120 15 szt. | kom  
45132 40 szt. | kom  
45131 40 szt. | kom  
45133 40 szt. | kom  
45142 25 szt. | kom  
45143 20 szt. | kom  
45140 20 szt. | kom

225x

Nu. specificație

45146

1



## ROSA

STROPITOARE,  
IMPULS PROFI

· impulse

0,7 bar min  
5,5 bar max

Nu. specificație

45162



24



## ROSA

STROPITOARE  
8 FUNCTII

· 8 function

0,7 bar min  
5,5 bar max

Nu. specificație

45154

48



## ROSA

STROPITOARE  
ROTATIVA 2 SENSURI

· rotary, 2 arms

0,7 bar min  
5,5 bar max

Nu. specificație

45153



24



## ROSA

STROPITOARE  
ROTATIVA 3 SENSURI

· rotary, 3 arms

0,7 bar min  
5,5 bar max

Nu. specificație

45152

24



## ROSA

STROPITOARE  
CU BALANSARE

· 17 jets ALU

0,7 bar min  
5,5 bar max

ALU

Nu. specificație

45158



6

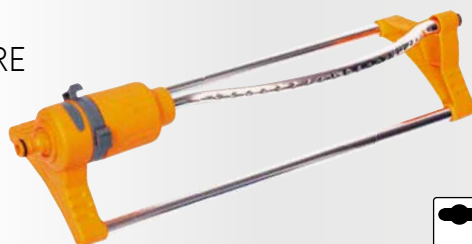

## ROSA

## STROPITOARE PIRAMIDALA

· pyramidal

0,7 bar min  
5,5 bar max

Nu. specificație

45167

12



## ROSA

STAND BAZA  
PENTRU  
STROPITOARE IMPULS0,7 bar min  
5,5 bar max

3/4"

Nu. specificație

45155



24



## ROSA

STROPITOARE IMPULS,  
STAND

· tripod

0,7 bar min  
5,5 bar maxNu. specificație  
impulse, tripod

45163



20



**ROSA**

**STROPITOARE TARUS**

· plastic point

0,7 bar min  
5,5 bar max

Nu. specificatie

45160 25



**ROSA**

**STROPITOARE PLATA CU ROBINET**

· stropitoare plata cu robinet

0,7 bar min  
5,5 bar max

Nu. specificatie

45156 12



**ROSA**

**TEMPORIZATOR APA**

· 0 - 120 min.

0,7 bar min  
5,5 bar max

3/4"

Nu. specificatie

45147 24



**ROSA**

**STROPITOARE, IMPULS**

· brass

0,7 bar min  
5,5 bar max

3/4"

Nu. specificatie

45150 12



**ROSA**

**STROPITOARE, IMPULS**

0,7 bar min  
5,5 bar max

3/4"

Nu. specificatie

45151 12



**ROSA**

**STROPITOARE, IMPULS**

0,7 bar min  
5,5 bar max

3/4"

Nu. specificatie

45168 plastic point 12  
45169 metal point 12



**ROSA**

**STROPITOARE, IMPULS**

0,7 bar min  
5,5 bar max

Nu. specificatie

45161 plastový hrot 20



**ROSA**

**STROPITOARE, IMPULS**

· 3 arms

0,7 bar min  
5,5 bar max

3/4"

Nu. specificatie

45164 plastic point 12



**ROSA**

**SUPORT TARUS**

3/4" Zn

Nu. specificatie

45159 12



**ROSA**

**SUPORT TARUS**

3/4"

Nu. specificatie

45179 12



**ROSA**

**SUPORT FIXARE FURTUN**

Nu. specificatie

45186 48



**ROSA**

**STROPITOARE ROTATIVA**

1"

Nu. specificatie

45185 20



**ROSA**

**STROPITOARE ROTATIVA**

3/4"

Nu. specificatie

45184 20



**ROSA**  
RACORD

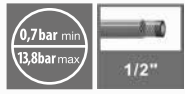

Nu. specificație  
45192 48

**ROSA**  
CONECTOR



Nu. specificație  
45194 48

**ROSA**  
CONECTOR  
CU STOP

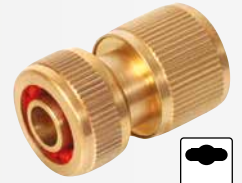

Nu. specificație  
45190 48

**ROSA**  
RACORD



Nu. specificație  
45193 48

**ROSA**  
CONECTOR



Nu. specificație  
45195 48

**ROSA**  
CONECTOR  
CU STOP



Nu. specificație  
45191 48

**ROSA**  
ADAPTOR



Nu. specificație  
45196 cu fi let interior 1/2" + 3/4" 48

**ROSA**  
ADAPTOR



Nu. specificație  
45197 cu fi let interior 3/4" 48

**ROSA**  
ADAPTOR



Nu. specificație  
45199 cu fi let interior 1" 48

**ROSA**  
ADAPTOR



Nu. specificație  
45198 cu fi let interior 3/4 + 1" 48

**ROSA**  
ADAPTOR



Nu. specificație  
45200 cu fi let exterior 3/4" 48

**ROSA**  
STROPITOARE



Nu. specificație  
45206 adjustable 48

**ROSA**  
ADAPTOR



Nu. specificație  
45203 adaptor cu 2 conectori 48

**ROSA**  
ADAPTOR

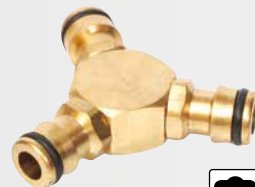

Nu. specificație  
45204 adaptor cu 3 conectori 48

CONECTOR



Nu. specificație  
45211 1" - 1" 25

**ROSA**  
SET GARNITURI

· Pentru articolele  
45110, 45111, 45118, 45120, 45121, 45123,  
45125, 45126, 45130, 45131, 45132, 45134,  
45135, 45152, 45153, 45154, 45155, 45156,  
45162, 45177, 45178, 45180, 45196, 45197,  
45198



Nu. specificație  
45175 1

**ROSA**  
GARNITURA  
CAUCIUC

50x



Nu. specificație  
45187 1

NEW



**ROSA**  
GRĂDINĂ FURTUN CURAT



| Nu.   | specificație |   |
|-------|--------------|---|
| 45342 | 1/2" 10 m    | 1 |
| 45343 | 1/2" 15 m    | 1 |
| 45344 | 1/2" 20 m    | 1 |
| 45345 | 1/2" 25 m    | 1 |
| 45346 | 1/2" 50 m    | 1 |
| 45341 | 3/4" 10 m    | 1 |
| 45347 | 3/4" 15 m    | 1 |
| 45348 | 3/4" 20 m    | 1 |
| 45349 | 3/4" 25 m    | 1 |
| 45351 | 3/4" 50 m    | 1 |
| 45352 | 1" 15 m      | 1 |
| 45353 | 1" 25 m      | 1 |
| 45354 | 1" 50 m      | 1 |

NEW



**FESTA AQUATIC**  
GRĂDINĂ FURTUN PROFI



| Nu.   | specificație |   |
|-------|--------------|---|
| 45372 | 1/2" 25 m    | 1 |
| 45373 | 1/2" 50 m    | 1 |
| 45374 | 3/4" 25 m    | 1 |
| 45375 | 3/4" 50 m    | 1 |
| 45376 | 1" 25 m      | 1 |
| 45377 | 1" 50 m      | 1 |



**ROSA**  
FURTUN SPIRALAT



| Nu.   | specificație |   |
|-------|--------------|---|
| 45300 | 7,5 m        | 6 |
| 45301 | 15 m         | 8 |



**ROSA**  
FURTUN GRADINA PE ROLA

| Nu.   | specificație |   |
|-------|--------------|---|
| 45178 | 1/2" 60 m    | 5 |



**ROSA**  
CARUCIOR CU FURTUN GRADINA

| Nu.   | specificație |   |
|-------|--------------|---|
| 45183 | 1/2" 60 m    | 5 |



**ROSA**  
CARUCIOR CU FURTUN GRADINA

| Nu.   | specificație |   |
|-------|--------------|---|
| 45177 | 1/2" 60 m    | 5 |

**ROSA**  
FURTUN GRADINA AUTOINFASURARE

| Nu.   | specificație |   |
|-------|--------------|---|
| 45182 | 1/2" 40 m    | 4 |



**ROSA**  
FURTUN GRADINA AUTOINFASURARE

· hose included 1/2" 20 m



| Nu.   | specificație |   |
|-------|--------------|---|
| 45176 |              | 1 |



**ROSA**  
SUPPORT FURTUN

| Nu.   | specificație |    |
|-------|--------------|----|
| 45174 |              | 60 |



**HOSE CARRIER**

· gradina din plastic, până la 30 m, 1/2"

| Nu.   | specificație |   |
|-------|--------------|---|
| 45350 | Max. 20 kg   | 1 |



## RACORD FURTUN

| Nu.   | specificație  |    |
|-------|---------------|----|
| 45220 | 1/2" fir 3/4" | 10 |
| 45221 | 3/4" fir 1"   | 10 |
| 45222 | 1" fir 1"     | 10 |



## RACORD CU OLANDEZA

| Nu.   | specificație  |    |
|-------|---------------|----|
| 45223 | 1/2" fir 3/4" | 10 |
| 45224 | 3/4" fir 1"   | 10 |
| 45225 | 1" fir 1"     | 10 |



## REDUCTOR

| Nu.   | specificație         |    |
|-------|----------------------|----|
| 45226 | 1/2" - 3/4" zăvit 1" | 10 |
| 45227 | 1" - 3/4" zăvit 1"   | 10 |
| 45228 | 1" - 1/2" zăvit 1"   | 10 |



## STROPITOARE

| Nu.   | specificație |    |
|-------|--------------|----|
| 45229 |              | 10 |



| Nu.   | diametru     |   |
|-------|--------------|---|
| 45603 | 16 - 25 mm   | 2 |
| 45604 | 20 - 32 mm   | 2 |
| 45605 | 25 - 40 mm   | 2 |
| 45606 | 30 - 45 mm   | 2 |
| 45607 | 32 - 50 mm   | 2 |
| 45608 | 40 - 60 mm   | 2 |
| 45609 | 50 - 70 mm   | 2 |
| 45610 | 60 - 80 mm   | 2 |
| 45611 | 70 - 90 mm   | 2 |
| 45612 | 80 - 100 mm  | 2 |
| 45613 | 90 - 110 mm  | 2 |
| 45614 | 100 - 120 mm | 2 |
| 45615 | 110 - 130 mm | 2 |
| 45616 | 120 - 140 mm | 2 |
| 45617 | 130 - 150 mm | 2 |
| 45618 | 140 - 160 mm | 2 |
| 45619 | 150 - 170 mm | 2 |



| Nu.   | diametru     | lățime |   |
|-------|--------------|--------|---|
| 45623 | 16 - 25 mm   | 9 mm   | 2 |
| 45624 | 20 - 32 mm   | 9 mm   | 2 |
| 45625 | 25 - 40 mm   | 12 mm  | 2 |
| 45626 | 30 - 45 mm   | 12 mm  | 2 |
| 45627 | 32 - 50 mm   | 12 mm  | 2 |
| 45628 | 40 - 60 mm   | 12 mm  | 2 |
| 45629 | 50 - 70 mm   | 12 mm  | 2 |
| 45630 | 60 - 80 mm   | 12 mm  | 2 |
| 45631 | 70 - 90 mm   | 12 mm  | 2 |
| 45632 | 80 - 100 mm  | 12 mm  | 2 |
| 45633 | 90 - 110 mm  | 12 mm  | 2 |
| 45634 | 100 - 120 mm | 12 mm  | 2 |
| 45635 | 110 - 130 mm | 12 mm  | 2 |
| 45636 | 120 - 140 mm | 12 mm  | 2 |
| 45637 | 130 - 150 mm | 12 mm  | 2 |
| 45638 | 140 - 160 mm | 12 mm  | 2 |
| 45639 | 150 - 170 mm | 12 mm  | 2 |

## COLIERE METALICE

| Nu.   | diametru   |   |
|-------|------------|---|
| 45600 | 8 - 12 mm  | 2 |
| 45601 | 10 - 16 mm | 2 |
| 45602 | 12 - 20 mm | 2 |

Zn

MOQ  
2

## COLIERE METALICE

| Nu.   | diametru   | lățime |   |
|-------|------------|--------|---|
| 45620 | 8 - 12 mm  | 9 mm   | 2 |
| 45621 | 10 - 16 mm | 9 mm   | 2 |
| 45622 | 12 - 20 mm | 9 mm   | 2 |

INOX

MOQ  
2

## ROBINET PENTRU GRADINA

| Nu.   |   |
|-------|---|
| 45105 | 8 |



## ROBINET PENTRU GRADINA

| Nu.   | specificație |    |
|-------|--------------|----|
| 45100 | 1/2"         | 12 |
| 45101 | 3/4"         | 10 |
| 45102 | 1"           | 6  |



## ROBINET CU BILA

| Nu.   | specificație |    |
|-------|--------------|----|
| 45106 | 1/2"         | 12 |
| 45107 | 3/4"         | 10 |
| 45108 | 1"           | 8  |



## STROPITOARE

MADE IN  
EU

| Nu.   | specificație |    |
|-------|--------------|----|
| 45280 | 2,5 l        | 10 |
| 45283 | 5 l          | 10 |
| 45285 | 10 l         | 10 |
| 45286 | 12 l         | 10 |
| 45287 | 15 l         | 10 |



## ROBINET COLT

| Nu.   | specificație |    |
|-------|--------------|----|
| 45104 | 1/2" x 3/8"  | 10 |





**FESTA**

**KÉZI PERMETEZŐ**

|                |                 |
|----------------|-----------------|
| max. pressure: | 2,5 Bar         |
| volume:        | 12 l            |
| length of hose | 3 m             |
| dimensions:    | 32 x 25 x 59 cm |

| Nu.   | specificație                  |   |
|-------|-------------------------------|---|
| 45249 | pulverizator de presiune 12 l | 1 |

**FESTA**

**PULVERIZATOR DE PRESIUNE**

| Nu.   | specificație |   |
|-------|--------------|---|
| 45247 | 12 l         | 1 |
| 45248 | 16 l         | 1 |

| Nu.   | specificație                 |   |
|-------|------------------------------|---|
| 45263 | furtunul de rezerva          | 1 |
| 45251 | set de schimb de vânzare     | 1 |
| 45254 | duza de rezerva              | 1 |
| 45257 | mănerul de rezerva           | 1 |
| 45261 | Stâlp de rezerva - 370 mm    | 1 |
| 45267 | Stâlp de rezerva 45 - 250 cm | 1 |
| 45268 | Stâlp de rezerva 65 - 260 cm | 1 |

**FESTA**

**PULVERIZATOR DE PRESIUNE**

| Nu.   | specificație |   |
|-------|--------------|---|
| 45244 | 3 l          | 6 |
| 45245 | 5 l          | 6 |
| 45246 | 8 l          | 6 |

| Nu.   | specificație              |   |
|-------|---------------------------|---|
| 45262 | furtunul de rezerva       | 1 |
| 45250 | set de schimb de vânzare  | 1 |
| 45253 | duza de rezerva           | 1 |
| 45256 | mănerul de rezerva        | 1 |
| 45260 | Stâlp de rezerva - 370 mm | 1 |

• pentru: 45244, 45245, 45246



• pentru: 45247, 45248

93 - 250 cm



**BARĂ TELESCOPICĂ PENTRU STROPITOARE, FIBERGLASS**

| Nu.   | tip         |            |   |
|-------|-------------|------------|---|
| 45267 | 45 - 250 cm | inox       | 1 |
| 45268 | 65 - 260 cm | fiberglass | 1 |

**BARĂ TELESCOPICĂ PENTRU STROPITOARE**

| Nu.   | specificație |   |
|-------|--------------|---|
| 45269 |              | 1 |



**FURTUN DE SCHIMB PENTRU STROPITOARE**

| Nu.   | tip                                     |   |
|-------|---|---|
| 45263 | pentru pulverizator 45247, 45248        | 1 |
| 45262 | pentru pulverizator 45244, 45245, 45246 | 1 |



**HERBICID BELL**

| Nu.   | velicost | lungime | lățime | înălțimea |   |
|-------|----------|---------|--------|-----------|---|
| 45265 | mic      | 230 mm  | 90 mm  | 130 mm    | 1 |
| 45266 | mare     | 370 mm  | 140 mm | 200 mm    | 1 |



**FESTA**

PULVERIZATOR



| Nu.   | tip   |    |
|-------|-------|----|
| 45242 | 1,5 l | 20 |
| 45241 | 2 l   | 20 |

PULVERIZATOR



| Nu.   | tip   |   |
|-------|-------|---|
| 45239 | 0,5 l | 1 |
| 45240 | 0,7 l | 1 |



**ROSA**

DUS 3 BRATE



| Nu.   | specificație |    |
|-------|--------------|----|
| 45171 | adjustable   | 12 |



**ROSA**

DUS 3 BRATE



| Nu.   | specificație |   |
|-------|--------------|---|
| 45170 | tripod       | 6 |



**ROSA**

DUS GRADINA MANUAL



| Nu.   | specificație |    |
|-------|--------------|----|
| 45172 | cu robinet   | 12 |
| 45173 | 10 funcție   | 12 |



**FESTA®**

system click  
ON - OFF



system click  
ON - OFF



system click  
ON - OFF

**FESTA®**

GREBLĂ DE PLASTIC

| Nu.   | numărul lamelelor | lățime | înălțimea |    |
|-------|-------------------|--------|-----------|----|
| 45327 | 13                | 240 mm | 200 mm    | 12 |

**FESTA®**

GREBLĂ DE PLASTIC

| Nu.   | numărul lamelelor | lățime |    |
|-------|-------------------|--------|----|
| 45325 | 12                | 410 mm | 12 |



system click  
ON - OFF



system click  
ON - OFF

**FESTA®**

GREBLĂ DE PLASTIC

| Nu.   | numărul lamelelor | lățime | înălțimea |    |
|-------|-------------------|--------|-----------|----|
| 45328 | 23                | 480 mm | 280 mm    | 12 |

**FESTA®**

GREBLĂ DE PLASTIC

| Nu.   | numărul lamelelor | lățime |    |
|-------|-------------------|--------|----|
| 45326 | 18                | 580 mm | 12 |



system click  
ON - OFF



system click  
ON - OFF

**FESTA®**

GREBLĂ DE PLASTIC

| Nu.   | numărul lamelelor | lățime | înălțimea |   |
|-------|-------------------|--------|-----------|---|
| 45329 | 35                | 760 mm | 310 mm    | 1 |

**FESTA®**

MATURA (PERIE)

| Nu.   | specificatie |    |
|-------|--------------|----|
| 45323 | 37 cm        | 16 |

**FESTA®**

COADĂ ALU

ALU



system click  
ON - OFF

| Nu.   | specificatie |    |
|-------|--------------|----|
| 45330 | 161 cm       | 24 |
| 45331 | 100 cm       | 24 |

**FESTA**METAL GREBLĂ  
REGLABIL

Zn

| Nu.   | numărul lamelor | duljina      |    |
|-------|-----------------|--------------|----|
| 44965 | 15              | 200 - 590 mm | 12 |

## METAL GREBLĂ REGLABIL



Zn

| Nu.   | numărul lamelor | težina | duljina      |    |
|-------|-----------------|--------|--------------|----|
| 45050 | 15              | 1200 g | 200 - 590 mm | 25 |

**FESTA**

## GREBLĂ METAL FRUNZE

· spring steel



| Nu.   | lățime | numărul lamelor |   |
|-------|--------|-----------------|---|
| 45071 | 55 cm  | 22              | 1 |

**FESTA**GREBLĂ METAL  
FRUNZE  
CU COADĂMOQ  
3

| Nu.   | lățime | lungime mânerului |   |
|-------|--------|-------------------|---|
| 61150 | 55 cm  | 160 cm            | 3 |



## GREBLĂ METAL FRUNZE

| Nu.   | lățime | numărul lamelor |    |
|-------|--------|-----------------|----|
| 45051 | 40 cm  | 22              | 60 |

GREBLĂ METAL  
FRUNZE  
CU COADĂMOQ  
3

| Nu.   | lățime | lungime mânerului |   |
|-------|--------|-------------------|---|
| 61130 | 40 cm  | 160 cm            | 3 |



## GREBLĂ METAL FRUNZE

| Nu.   | lățime | numărul lamelor |    |
|-------|--------|-----------------|----|
| 45052 | 45 cm  | 22              | 36 |

GREBLĂ METAL  
FRUNZE  
CU COADĂMOQ  
3

| Nu.   | lățime | lungime mânerului |   |
|-------|--------|-------------------|---|
| 61131 | 45 cm  | 160 cm            | 3 |



GREBLĂ DE PLASTIC FRUNZE



| Nu.   | lățime | numărul lamelelor |    |
|-------|--------|-------------------|----|
| 45320 | 60 cm  | 24                | 10 |

GREBLĂ DE PLASTIC FRUNZE CU COADĂ



| Nu.   | lățime | numărul lamelelor | lungime mânerului |   |
|-------|--------|-------------------|-------------------|---|
| 61132 | 60 cm  | 24                | 160 cm            | 3 |



GREBLĂ DE PLASTIC FRUNZE



| Nu.   | lățime | numărul lamelelor |    |
|-------|--------|-------------------|----|
| 45055 | 50 cm  | 22                | 10 |

GREBLĂ DE PLASTIC FRUNZE CU COADĂ



| Nu.   | lățime | numărul lamelelor | lungime mânerului |   |
|-------|--------|-------------------|-------------------|---|
| 61133 | 50 cm  | 22                | 160 cm            | 3 |



GREBLĂ DE PLASTIC FRUNZE 23 DINTI



| Nu.   | lățime | numărul lamelelor |    |
|-------|--------|-------------------|----|
| 45321 | 40 cm  | 23                | 20 |

GREBLĂ DE PLASTIC FRUNZE 23 DINTI CU COADĂ



| Nu.   | numărul lamelelor | lungime mânerului |   |
|-------|-------------------|-------------------|---|
| 61134 | 23                | 160 cm            | 3 |



GREBLĂ DE PLASTIC FRUNZE 23 DINTI



| Nu.   | lățime | numărul lamelelor |    |
|-------|--------|-------------------|----|
| 45054 | 40 cm  | 23                | 10 |

GREBLĂ DE PLASTIC FRUNZE 23 DINTI CU COADĂ



| Nu.   | lățime | numărul lamelelor | lungime mânerului |   |
|-------|--------|-------------------|-------------------|---|
| 61135 | 40 cm  | 23                | 160 cm            | 3 |



GREBLĂ DE PLASTIC 16 DINTI



| Nu.   | lățime | numărul lamelelor |    |
|-------|--------|-------------------|----|
| 45053 | 58 cm  | 16                | 35 |

GREBLĂ DE PLASTIC 16 DINTI CU COADĂ



| Nu.   | lățime | numărul lamelelor | lungime mânerului |   |
|-------|--------|-------------------|-------------------|---|
| 61141 | 58 cm  | 16                | 160 cm            | 3 |



## GREBLĂ DE PLASTIC 14 DINTI



| Nu.   | lățime | numărul de dinți |   |
|-------|--------|------------------|---|
| 45070 | 41 cm  | 14               | 4 |

## GREBLĂ DE PLASTIC 14 DINTI CU COADĂ

MOQ  
3

| Nu.   | lățime | numărul de dinți | lungime mânerului |   |
|-------|--------|------------------|-------------------|---|
| 61142 | 41 cm  | 14               | 160 cm            | 3 |

## GREBLĂ METAL

| Nu.   | lățime | numărul de dinți |    |
|-------|--------|------------------|----|
| 61030 | 24 cm  | 10               | 24 |
| 61031 | 29 cm  | 12               | 24 |
| 61032 | 34 cm  | 14               | 24 |
| 61033 | 40 cm  | 16               | 24 |



## GREBLĂ METAL CU COADĂ

| Nu.   | lățime | numărul de dinți | lungime mânerului |   |
|-------|--------|------------------|-------------------|---|
| 61060 | 24 cm  | 10               | 160 cm            | 3 |
| 61061 | 29 cm  | 12               | 160 cm            | 3 |
| 61062 | 34 cm  | 14               | 160 cm            | 3 |
| 61063 | 40 cm  | 16               | 160 cm            | 3 |

MOQ  
3

## GREBLĂ METAL

\* vopsea cu ciocan

| Nu.   | lățime | numărul de dinți |    |
|-------|--------|------------------|----|
| 61045 | 30 cm  | 12               | 25 |
| 61046 | 39 cm  | 14               | 25 |
| 61047 | 45 cm  | 16               | 25 |



## GREBLĂ METAL CU COADĂ

| Nu.   | lățime | numărul de dinți | lungime mânerului |   |
|-------|--------|------------------|-------------------|---|
| 61143 | 30 cm  | 12               | 160 cm            | 3 |
| 61144 | 39 cm  | 14               | 160 cm            | 3 |
| 61145 | 45 cm  | 16               | 160 cm            | 3 |

MOQ  
3

## GREBLĂ ARETATION

| Nu.   | lățime | numărul de dinți |    |
|-------|--------|------------------|----|
| 61048 | 35 cm  | 11   21          | 12 |



## GREBLĂ ARETATION CU COADĂ

| Nu.   | lățime | numărul de dinți | lungime mânerului |   |
|-------|--------|------------------|-------------------|---|
| 61146 | 35 cm  | 11   21          | 160 cm            | 3 |

MOQ  
3

## GREBLĂ METAL CU COADĂ FIBRA

| Nu.   | lățime | numărul de dinți | lungime mânerului |   |
|-------|--------|------------------|-------------------|---|
| 61034 | 34 cm  | 14               | 160 cm            | 3 |

MOQ  
3

**FESTA**  
CAZMA



| Nu.   | specificație | lungime mânerului |   |
|-------|--------------|-------------------|---|
| 61006 | 19 x 28 cm   | 120 cm            | 5 |

**FESTA**

CAZMA  
MICĂ  
ASCUȚITĂ

• Potrivit pentru muncă în seră



| Nu.   | specificație | lungime mânerului |   |
|-------|--------------|-------------------|---|
| 61008 | 19 x 28 cm   | 85 cm             | 5 |

**FESTA**  
CAZMA



| Nu.   | specificație | lungime mânerului |   |
|-------|--------------|-------------------|---|
| 61005 | 20 x 29 cm   | 120 cm            | 5 |

**FESTA**



**FESTA**  
CAZMA,  
EXTINS

• sau persoane mai mari de 180 cm

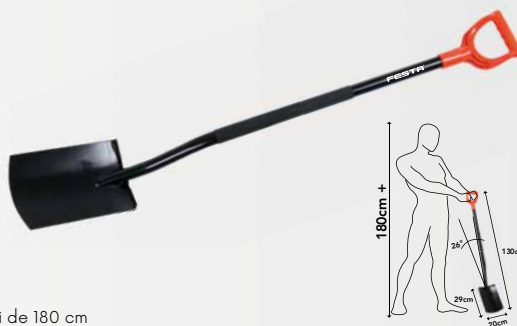

| Nu.   | specificație | lungime mânerului |   |
|-------|--------------|-------------------|---|
| 61157 | 20 x 29 cm   | 130 cm            | 5 |

**FESTA**

CAZMA,  
EXTINS



| Nu.   | specificație | lungime mânerului |   |
|-------|--------------|-------------------|---|
| 61158 | 19 x 28 cm   | 130 cm            | 5 |

**FESTA**  
LOPATĂ



| Nu.   | specificație | lungime mânerului |   |
|-------|--------------|-------------------|---|
| 61155 | 24 x 29 cm   | 120 cm            | 5 |

**FESTA**

FURCA



| Nu.   | specificație | lungime mânerului |   |
|-------|--------------|-------------------|---|
| 61156 | 19 x 28 cm   | 130 cm            | 5 |

**FESTA**  
FURCA



| Nu.   | specificație | lungime mânerului |   |
|-------|--------------|-------------------|---|
| 61007 | 18 x 28 cm   | 130 cm            | 5 |

**FESTA**  
FURCA

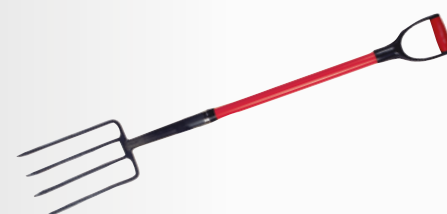

| Nu.   | specificație | lungime mânerului |    |
|-------|--------------|-------------------|----|
| 61010 | 18 x 30 cm   | 95 cm             | 12 |

CAZMA  
COADA  
FIBRA



| Nu.   | specificație | lungime mânerului |    |
|-------|--------------|-------------------|----|
| 61029 | 19 x 30 cm   | 105 cm            | 12 |

CAZMA  
COADA  
FIBRA



| Nu.   | specificație | lungime mânerului |    |
|-------|--------------|-------------------|----|
| 61015 | 19 x 30 cm   | 105 cm            | 12 |



### LOPATĂ ALUMINIU CU COADĂ

· Mâner de fag

ALU

MOQ  
3

| Nu.   | specificație | lungime mânerului |   |
|-------|--------------|-------------------|---|
| 61057 | 26 x 29 cm   | 130 cm            | 3 |
| 61056 | 34 x 30 cm   | 130 cm            | 3 |



### LOPATĂ ALUMINIU

ALU

| Nu.   | specificație |    |
|-------|--------------|----|
| 61026 | 26 x 29 cm   | 10 |
| 61025 | 34 x 30 cm   | 10 |



### LOPATĂ CU COADĂ

MOQ  
3

| Nu.   | specificație | lungime mânerului |   |
|-------|--------------|-------------------|---|
| 61089 | 35 x 35 cm   | 130 cm            | 3 |



### LOPATĂ

| Nu.   | specificație |    |
|-------|--------------|----|
| 61021 | 35 x 35 cm   | 10 |



### LOPATĂ CU COADĂ

· vopsea cu ciocan  
· mâner de fag

MOQ  
3

| Nu.   | specificație | lungime mânerului |   |
|-------|--------------|-------------------|---|
| 61050 | 26 x 28 cm   | 130 cm            | 3 |



### LOPATĂ

· kalapács festék  
· vopsea cu ciocan

| Nu.   | specificație |    |
|-------|--------------|----|
| 61000 | 26 x 28 cm   | 12 |



### LOPATĂ CU COADĂ

· mâner de fag

MOQ  
3

| Nu.   | specificație | lungime mânerului |   |
|-------|--------------|-------------------|---|
| 61088 | 26 x 28 cm   | 130 cm            | 3 |



### LOPATĂ

| Nu.   | specificație |    |
|-------|--------------|----|
| 61020 | 26 x 28 cm   | 12 |



### LOPATĂ CU COADĂ

· vopsea cu ciocan  
· Mâner de fag

MOQ  
3

| Nu.   | specificație | lungime mânerului |   |
|-------|--------------|-------------------|---|
| 61051 | 24 x 29 cm   | 130 cm            | 3 |



### LOPATĂ

· vopsea cu ciocan

| Nu.   | specificație |    |
|-------|--------------|----|
| 61001 | 24 x 29 cm   | 12 |







LOPATĂ

| Nu.   | specificație |    |
|-------|--------------|----|
| 61022 | 24 x 29 cm   | 12 |



LOPATĂ  
CU COADĂ

· Mâner de fag

MOQ  
3

| Nu.   | specificație | lungime mânerului |   |
|-------|--------------|-------------------|---|
| 61090 | 24 x 29 cm   | 130 cm            | 3 |
| 61053 | 24 x 29 cm   | 130 cm "T", mâner | 3 |



LOPATĂ HOLSTEIN

| Nu.   | specificație |    |
|-------|--------------|----|
| 61058 | 25 x 27 cm   | 12 |



LOPATĂ HOLSTEIN CU COADĂ

· Mâner de fag

MOQ  
3

| Nu.   | specificație | lungime mânerului |   |
|-------|--------------|-------------------|---|
| 61059 | 25 x 27 cm   | 130 cm            | 3 |



LOPATĂ

· vopsea cu ciocan

| Nu.   | specificație |    |
|-------|--------------|----|
| 61002 | 19 x 27 cm   | 12 |



LOPATĂ CU COADĂ

· Mâner de fag

MOQ  
3

| Nu.   | specificație | lungime mânerului |   |
|-------|--------------|-------------------|---|
| 61052 | 19 x 27 cm   | 130 cm            | 3 |



LOPATĂ

| Nu.   | specificație |    |
|-------|--------------|----|
| 61024 | 19 x 27 cm   | 12 |



LOPATĂ CU COADĂ

MOQ  
3

| Nu.   | specificație | lungime mânerului |   |
|-------|--------------|-------------------|---|
| 61054 | 19 x 27 cm   | 130 cm            | 3 |



LOPATĂ DE PLASTIC

| Nu.   | specificație |    |
|-------|--------------|----|
| 61027 | 24 x 26 cm   | 12 |



### CAZMA CU COADĂ

• vopsea cu ciocan

MOQ  
3

| Nu.   | specificație | lungime mânerului |   |
|-------|--------------|-------------------|---|
| 61161 | 22 x 30 cm   | 90 cm             | 3 |



### CAZMA

• vopsea cu ciocan

| Nu.   | specificație |    |
|-------|--------------|----|
| 61004 | 22 x 30 cm   | 12 |



### CAZMA CU COADĂ

MOQ  
3

| Nu.   | specificație | lungime mânerului |   |
|-------|--------------|-------------------|---|
| 61097 | 19 x 30 cm   | 90 cm             | 3 |



### CAZMA

| Nu.   | specificație |    |
|-------|--------------|----|
| 61019 | 22 x 30 cm   | 12 |



### CAZMA CU COADĂ

| Nu.   | specificație | lungime mânerului | MOQ |
|-------|--------------|-------------------|-----|
| 61162 | 22 x 25 cm   | 90 cm             | 3   |
| 61223 | mâner        | 90 cm             | 1   |



### CAZMA

| Nu.   | specificație |    |
|-------|--------------|----|
| 61013 | 22 x 25 cm   | 12 |



### CAZMA CU COADĂ

• vopsea cu ciocan

MOQ  
3

| Nu.   | specificație | lungime mânerului |   |
|-------|--------------|-------------------|---|
| 61163 | 21 x 30 cm   | 90 cm             | 3 |



### CAZMA

• vopsea cu ciocan

| Nu.   | specificație |    |
|-------|--------------|----|
| 61003 | 21 x 30 cm   | 12 |



CAZMA

| Nu.   | specificație |    |
|-------|--------------|----|
| 61018 | 21 x 30 cm   | 12 |



CAZMA CU COADĂ

MOQ  
3

| Nu.   | specificație | lungime mânerului |   |
|-------|--------------|-------------------|---|
| 61098 | 21 x 30 cm   | 90 cm             | 3 |



CAZMA

| Nu.   | specificație |    |
|-------|--------------|----|
| 61014 | 14 x 37 cm   | 12 |



CAZMA CU COADĂ

| Nu.   | specificație | lungime mânerului | MOQ |  |
|-------|--------------|-------------------|-----|--|
| 61164 | 14 x 37 cm   | 90 cm             | 3   |  |
| 61203 | mâner        | 90 cm             | 1   |  |



FURCA

| Nu.   | specificație |    |
|-------|--------------|----|
| 61009 | 20 x 32 cm   | 12 |



FURCA CU COADĂ

MOQ  
3

| Nu.   | specificație | lungime mânerului |   |
|-------|--------------|-------------------|---|
| 61165 | 20 x 32 cm   | 90 cm             | 3 |



FURCA

| Nu.   | specificație |    |
|-------|--------------|----|
| 61012 | 22 x 30 cm   | 12 |



FURCA CU COADĂ

| Nu.   | specificație | lungime mânerului | MOQ |  |
|-------|--------------|-------------------|-----|--|
| 61166 | 22 x 30 cm   | 90 cm             | 3   |  |
| 61222 | mâner        | 90 cm             | 1   |  |



FURCA

| Nu.   | specificație |    |
|-------|--------------|----|
| 61044 | 20 x 30 cm   | 12 |



FURCA CU COADĂ

| Nu.   | specificație | lungime mânerului | MOQ |  |
|-------|--------------|-------------------|-----|--|
| 61028 | 20 x 30 cm   | 90 cm             | 3   |  |
| 61209 | mâner        | 90 cm             | 1   |  |



### SAPA ASCUTIT CU COADĂ

| Nu.   | specificație | lungime mânerului | MOQ |  |
|-------|--------------|-------------------|-----|--|
| 61111 | 0,4 kg       | 120 cm            | 3   |  |
| 61112 | 0,6 kg       | 120 cm            | 3   |  |
| 61224 | mâner        | 120 cm            | 1   |  |

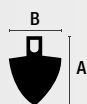

### SAPA ASCUTIT

| Nu.   | specificație | A      | B      | MOQ |
|-------|--------------|--------|--------|-----|
| 61035 | 0,4 kg       | 180 mm | 125 mm | 1   |
| 61036 | 0,6 kg       | 230 mm | 160 mm | 30  |



### SAPA ASCUTIT CU COADĂ

| Nu.   | specificație | lungime mânerului | MOQ |  |
|-------|--------------|-------------------|-----|--|
| 61114 | 0,6 kg       | 120 cm            | 3   |  |
| 61224 | mâner        | 120 cm            | 1   |  |

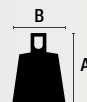

### SAPA ASCUTIT

| Nu.   | specificație | A      | B      | MOQ |
|-------|--------------|--------|--------|-----|
| 61038 | 0,6 kg       | 165 mm | 135 mm | 20  |



### SAPA ASCUTITA CU COADĂ

MOQ 3

| Nu.   | specificație | lungime mânerului | MOQ |  |
|-------|--------------|-------------------|-----|--|
| 61290 | 75 mm        | 120 cm            | 3   |  |
| 61291 | 125 mm       | 120 cm            | 3   |  |
| 61292 | 175 mm       | 120 cm            | 3   |  |

### SAPA ASCUTITA

| Nu.   | specificație | MOQ |
|-------|--------------|-----|
| 61067 | 75 mm        | 1   |
| 61068 | 125 mm       | 1   |
| 61069 | 175 mm       | 1   |



### SAPA ASCUTITA CU COADĂ

MOQ 3

| Nu.   | specificație | lungime mânerului | MOQ |  |
|-------|--------------|-------------------|-----|--|
| 61293 | 140 mm       | 120 cm            | 3   |  |

### SAPA ASCUTITA

| Nu.   | specificație | MOQ |
|-------|--------------|-----|
| 61070 | 140 mm       | 40  |



### TARNACOP COADĂ LEMN

MOQ 3

| Nu.   | specificație | lungime mânerului | MOQ |  |
|-------|--------------|-------------------|-----|--|
| 61121 | 1,5 kg       | 95 cm             | 3   |  |
| 61042 | 2,5 kg       | 95 cm             | 3   |  |

### TARNACOP

| Nu.   | specificație | MOQ |
|-------|--------------|-----|
| 61120 | 1,5 kg       | 6   |
| 61040 | 2,5 kg       | 6   |



**FESTA**

LOPATA PENTRU ZAPADA



| Nu.   | specificație          |    |
|-------|-----------------------|----|
| 60006 | 46 x 34 cm            | 12 |
| 60206 | 46 x 34 cm, asamblate | 1  |

**FESTA**

LOPATA PENTRU ZAPADA



| Nu.   | specificație          |    |
|-------|-----------------------|----|
| 60008 | 50 x 34 cm            | 12 |
| 60208 | 50 x 34 cm, asamblate | 1  |

LOPATA PENTRU ZAPADA



MADE IN EU

| Nu.   | specificație          |    |
|-------|-----------------------|----|
| 60001 | 48 x 40 cm            | 10 |
| 60201 | 48 x 40 cm, asamblate | 1  |

LOPATA PENTRU ZAPADA



ALU

| Nu.   | specificație          |    |
|-------|-----------------------|----|
| 60012 | 50 x 38 cm            | 12 |
| 60212 | 50 x 38 cm, asamblate | 1  |



RACLETA GHEATA

| Nu.   | specificație |   |
|-------|--------------|---|
| 60022 | 20 cm        | 3 |

MOQ 3

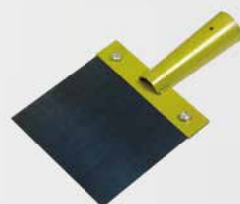

RACLETA GHEATA

| Nu.   | specificație |    |
|-------|--------------|----|
| 60018 | 15 cm        | 20 |
| 60019 | 20 cm        | 24 |
| 60020 | 30 cm        | 20 |
| 61201 | mâner 130 cm | 10 |



SARE RUTIER

| Nu.   | specificație |   |
|-------|--------------|---|
| 43300 | 10 kg        | 1 |
| 43301 | 25 kg        | 1 |



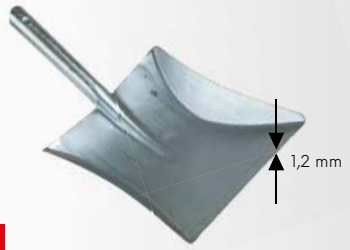

**FESTA**

FARAS

| Nu.   | specificație |    |
|-------|--------------|----|
| 52176 | 22 x 23 cm   | 24 |

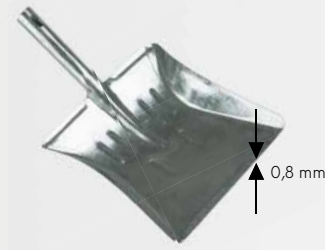

FARAS

Zn

| Nu.   | specificație |    |
|-------|--------------|----|
| 52175 | 22 x 23 cm   | 50 |



FARAS + PERIE SET

MADE IN EU

| Nu.   | specificație |    |
|-------|--------------|----|
| 52168 |              | 26 |



FARAS + PERIE SET

MADE IN EU

| Nu.   | specificație |    |
|-------|--------------|----|
| 52173 |              | 26 |



PERIE DE OȚEL PENTRU ÇURĂȚAREA ROSTURILOR, CU COADĂ

| Nu.   | lungime mânerului |   |
|-------|-------------------|---|
| 52198 | 140 cm            | 1 |



PERIE DE MANA

MADE IN EU

| Nu.   | specificație |    |
|-------|--------------|----|
| 52119 | 29 cm        | 24 |



MATURA (PERIE)

MADE IN EU

| Nu.   | specificație         |   |
|-------|----------------------|---|
| 52197 | 30 cm 120 cm de lemn | 3 |

MOQ 3



MATURA (PERIE)

MADE IN EU

| Nu.   | specificație     |    |
|-------|------------------|----|
| 52108 | 30 cm fir        | 25 |
| 61172 | coadă 120 cm fir | 1  |



MATURA (PERIE)

| Nu.   | specificație     |   |
|-------|------------------|---|
| 52135 | 145 cm 5x cusute | 1 |



system click ON - OFF

**FESTA**

MATURA (PERIE)

| Nu.   | specificație |    |
|-------|--------------|----|
| 45323 | 37 cm        | 16 |



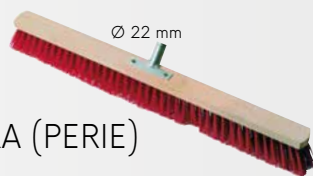

MATURA (PERIE)



| Nu.   | specificație |  |    |
|-------|--------------|--|----|
| 52101 | 30 cm        |  | 10 |
| 52102 | 40 cm        |  | 10 |
| 52103 | 50 cm        |  | 10 |
| 52104 | 60 cm        |  | 10 |
| 52105 | 80 cm        |  | 10 |

MATURA (PERIE)



| Nu.   | specificație | lungime mânerului |   |
|-------|--------------|-------------------|---|
| 52190 | 30 cm        | 150 cm            | 3 |
| 52191 | 40 cm        | 150 cm            | 3 |
| 52192 | 50 cm        | 150 cm            | 3 |
| 52193 | 60 cm        | 150 cm            | 3 |
| 52194 | 80 cm        | 150 cm            | 3 |



MATURA (PERIE)



| Nu.   | specificație |  |    |
|-------|--------------|--|----|
| 52160 | 40 cm        |  | 10 |
| 52161 | 50 cm        |  | 10 |
| 52162 | 60 cm        |  | 10 |
| 52163 | 70 cm        |  | 10 |
| 52164 | 80 cm        |  | 10 |

MATURA (PERIE)



| Nu.   | specificație | lungime mânerului |   |
|-------|--------------|-------------------|---|
| 52185 | 40 cm        | 150 cm            | 3 |
| 52186 | 50 cm        | 150 cm            | 3 |
| 52187 | 60 cm        | 150 cm            | 3 |
| 52188 | 70 cm        | 150 cm            | 3 |
| 52189 | 80 cm        | 150 cm            | 3 |



MATURA (PERIE)



| Nu.   | specificație |  |   |
|-------|--------------|--|---|
| 52114 | 28 cm fir    |  | 1 |

MATURA (PERIE)



| Nu.   | specificație | lungime mânerului |   |
|-------|--------------|-------------------|---|
| 52116 | 28 cm        | 130 cm            | 3 |



MATURA (PERIE)



| Nu.   | specificație   |  |    |
|-------|----------------|--|----|
| 52113 | 30 cm fir      |  | 26 |
| 52115 | 30 cm fără fir |  | 26 |

MATURA (PERIE)



| Nu.   | specificație         |  |   |
|-------|----------------------|--|---|
| 52195 | 30 cm 150 cm de lemn |  | 3 |
| 52196 | 30 cm 130 cm ALU     |  | 3 |



UNEALTA PENTRU INTINS

| Nu.   | specificație         |  |    |
|-------|----------------------|--|----|
| 15886 | 450 mm mâner Ø 23 mm |  | 48 |
| 15887 | 600 mm mâner Ø 23 mm |  | 48 |
| 15888 | 750 mm mâner Ø 23 mm |  | 32 |

MATURA (PERIE)



| Nu.   | specificație         |  |    |
|-------|----------------------|--|----|
| 52109 | 25 cm 120 cm de lemn |  | 12 |

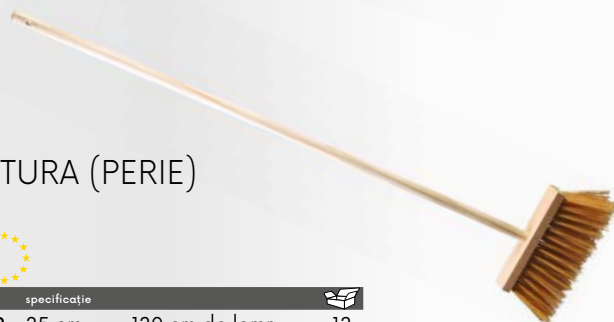



FESTA

## PERIE DE OȚEL

| Nu.   | specificație |                 |       |
|-------|--------------|-----------------|-------|
| 22135 | 6 x 19 cm    | fără mâner      | 8     |
| 22137 | 6 x 19 cm    | cu coadă 140 cm | MOQ 3 |



FESTA

## PERIE DE NAILON

| Nu.   | specificație |                 |       |
|-------|--------------|-----------------|-------|
| 22136 | 6 x 19 cm    | fără mâner      | 8     |
| 22138 | 6 x 19 cm    | cu coadă 140 cm | MOQ 3 |



## MOP

| Nu.   | specificație |  |    |
|-------|--------------|--|----|
| 52110 | 30 cm        |  | 16 |

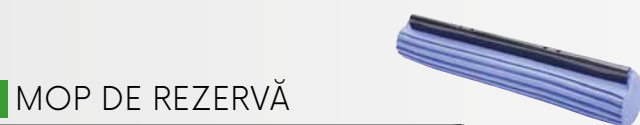

## MOP DE REZERVĂ

| Nu.   | specificație |  |   |
|-------|--------------|--|---|
| 52111 | 30 cm        |  | 1 |



FESTA

## COADĂ ALU

ALU

| Nu.   | specificație |  |    |
|-------|--------------|--|----|
| 45330 | 161 cm       |  | 24 |
| 45331 | 100 cm       |  | 24 |

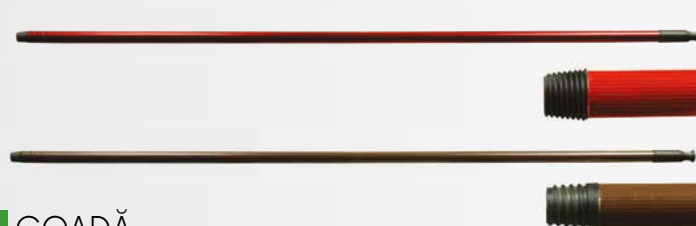
system click  
ON - OFF

## COADĂ

ALU MADE IN EU

| Nu.   | specificație |  |   |
|-------|--------------|--|---|
| 52126 | 130 cm, fir  |  | 1 |



## BRUSH COADĂ MATURA

MADE IN EU

| Nu.   | specificație         |                |   |
|-------|----------------------|----------------|---|
| 61172 | 120 cm de lemn coadă |                | 1 |
| 61192 | 150 cm de lemn coadă | for 52195      | 1 |
| 61193 | 150 cm de lemn coadă | for 52185 - 94 | 1 |
| 61194 | 140 cm de lemn coadă |                | 1 |



## COADĂ LEMN

Ø 22 mm

MADE IN EU

| Nu.   | specificație |   | Nu.   | specificație |   |
|-------|--------------|---|-------|--------------|---|
| 61171 | 1,2 m        | 1 | 61175 | 1,6 m        | 1 |
| 61173 | 1,4 m        | 1 | 61176 | 1,7 m        | 1 |
| 61174 | 1,5 m        | 1 | 61177 | 1,8 m        | 1 |



## COADĂ LOPATA



| Nu.   | specificație |  |    |
|-------|--------------|--|----|
| 61200 | 130 cm       |  | 10 |

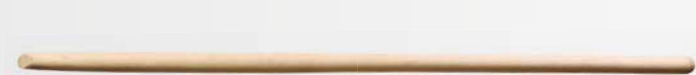

## COADĂ HARLET



| Nu.   | specificație |  |    |
|-------|--------------|--|----|
| 61201 | 130 cm, egal |  | 10 |



## COADĂ CAZMA



| Nu.   | specificație |  |    |
|-------|--------------|--|----|
| 61208 | 90 cm        |  | 10 |



## COADĂ HARLET „T”



| Nu.   | specificație  |  |    |
|-------|---------------|--|----|
| 61202 | 130 cm, drept |  | 10 |





## COADĂ CANCIOG



| Nu.   | specificație |    |
|-------|--------------|----|
| 61215 | 160 cm       | 10 |



## COADĂ TOPOR



| Nu.   | specificație                 |    |
|-------|------------------------------|----|
| 61204 | 95 cm, restrânge (pro 61120) | 10 |
| 61205 | 95 cm                        | 10 |



## COADĂ GREBLĂ PVC



| Nu.   | specificație |    |
|-------|--------------|----|
| 61195 | 120 cm       | 10 |

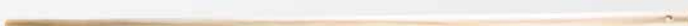

## COADĂ GREBLĂ



| Nu.   | specificație | suitable for |    |
|-------|--------------|--------------|----|
| 61250 | 160 cm       | 45051, 61048 | 20 |
| 61251 | 160 cm       | 45052        | 20 |
| 61252 | 160 cm       | 45320        | 20 |
| 61253 | 160 cm       | 45053        | 20 |
| 61254 | 160 cm       | 45054        | 20 |
| 61255 | 160 cm       | 45070        | 20 |
| 61256 | 160 cm       | 45055        | 20 |



## COADĂ CAZMA



| Nu.   | specificație |    |
|-------|--------------|----|
| 61207 | 100 cm       | 10 |



## COADĂ SAPA



| Nu.   | specificație |    |
|-------|--------------|----|
| 61219 | 120 cm       | 10 |



## COADĂ GREBLĂ



| Nu.   | specificație |    |
|-------|--------------|----|
| 61183 | 150 cm       | 10 |
| 61184 | 160 cm       | 10 |
| 61189 | 170 cm       | 10 |
| 61190 | 180 cm       | 10 |



## MANER

| Nu.   | specificație |    |
|-------|--------------|----|
| 61230 |              | 10 |

61079



120 cm

80 cm

| Nu.   |    |
|-------|----|
| 61005 | 15 |
| 61006 | 15 |
| 61050 | 15 |
| 61051 | 15 |
| 61052 | 15 |
| 61079 | 1  |
| 61097 | 15 |
| 61098 | 15 |

61077



• Fotografii ilustrative

## SUPORT PROMOȚIONAL PENTRU LOPEȚI ȘI LOPATA

| Nu.   | specificație         |   |
|-------|----------------------|---|
| 61077 | stau cu lopei i pica | 1 |
| 61079 | stau cu palet        | 1 |

## SUPORT PENTRU UNELE DE GRĂDINĂRIT

5x

| Nu.   | specificație |    |
|-------|--------------|----|
| 51184 |              | 12 |



role de cauciuc rotative



## SUPORT PENTRU UNELE DE GRĂDINĂRIT

| Nu.   | specificație |    |
|-------|--------------|----|
| 51185 | 45 cm        | 15 |



• Fotografii ilustrative



## PLASA PENTRU INSECTE

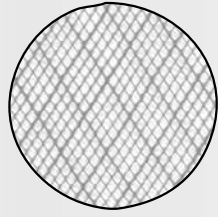

| Nu.   | specificație        |  |   |
|-------|---------------------|--|---|
| 40100 | 1 x 25 m - PE alb   |  | 1 |
| 40120 | 1,2 x 25 m - PE alb |  | 1 |

## PLASA PENTRU INSECTE

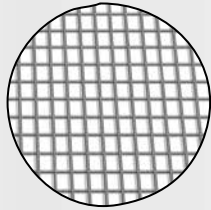

ALU Zn

| Nu.   | specificație             |  |   |
|-------|--------------------------|--|---|
| 42101 | 1 x 30 m - ALUMINIUM     |  | 2 |
| 42103 | 1 x 30 m - sârmă zincată |  | 2 |

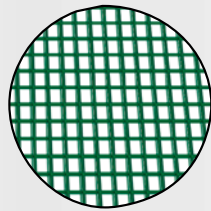
PLASA PENTRU INSECTE  
SARMA VERDE

| Nu.   | specificație                          |  |   |
|-------|---------------------------------------|--|---|
| 42102 | 1x30m - Sârmă de oțel acoperită verde |  | 2 |

## PLASA FIBRA STICLA

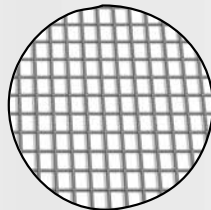

| Nu.   | specificație |     |   |  |
|-------|--------------|-----|---|--|
| 41083 | 0,8 x 30 m   | alb | 6 |  |
| 41103 | 1 x 30 m     | alb | 6 |  |
| 41123 | 1,2 x 30 m   | alb | 6 |  |
| 41153 | 1,5 x 30 m   | alb | 6 |  |

| Nu.   | specificație |         |   |  |
|-------|--------------|---------|---|--|
| 41082 | 0,8 x 30 m   | alb-gri | 6 |  |
| 41102 | 1 x 30 m     | alb-gri | 6 |  |
| 41122 | 1,2 x 30 m   | alb-gri | 6 |  |
| 41152 | 1,5 x 30 m   | alb-gri | 6 |  |

| Nu.   | specificație |     |   |  |
|-------|--------------|-----|---|--|
| 41050 | 0,5 x 30 m   | gri | 6 |  |
| 41080 | 0,8 x 30 m   | gri | 6 |  |
| 41100 | 1 x 30 m     | gri | 6 |  |
| 41120 | 1,2 x 30 m   | gri | 6 |  |
| 41150 | 1,5 x 30 m   | gri | 6 |  |

| Nu.   | specificație |       |   |  |
|-------|--------------|-------|---|--|
| 41081 | 0,8 x 30 m   | negru | 6 |  |
| 41101 | 1 x 30 m     | negru | 6 |  |
| 41121 | 1,2 x 30 m   | negru | 6 |  |
| 41151 | 1,5 x 30 m   | negru | 6 |  |





PLASA PENTRU FEREASTRA - ALBA



| Nu.   | specificație      |       |    |
|-------|-------------------|-------|----|
| 40050 | 150 x 130 cm      | 5,6 m | 10 |
| 40052 | 150 x 180 cm      | 6,6 m | 10 |
| 40054 | 150 x 90 cm       | 4,8 m | 10 |
| 40056 | 220 x 75 cm 2 buc | 5,8 m | 10 |



PLASA PENTRU FEREASTRA - GRI



| Nu.   | specificație |       |    |
|-------|--------------|-------|----|
| 40051 | 150 x 130 cm | 5,6 m | 10 |
| 40053 | 150 x 180 cm | 6,6 m | 10 |
| 40055 | 150 x 90 cm  | 4,8 m | 10 |



PLASA PENTRU FEREASTRA - NEAGRA



| Nu.   | specificație |       |    |
|-------|--------------|-------|----|
| 40057 | 150 x 130 cm | 5,6 m | 10 |
| 40058 | 150 x 180 cm | 6,6 m | 10 |
| 40059 | 150 x 90 cm  | 4,8 m | 10 |



PLASA PENTRU INSECTE

| Nu.   | specificație |   |
|-------|--------------|---|
| 40060 | 9 mm   7 m   | 1 |

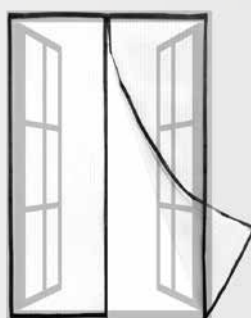

PERDEAUA USII IMPOTRIVA INSECTELOR MAGNETIC - ANTRACIT



| Nu.   | specificație |   |
|-------|--------------|---|
| 40077 | 100 x 220 cm | 1 |



PERDEA

· dimensiune variabilă 60 - 120 cm

| Nu.   | specificație          |  |    |
|-------|-----------------------|--|----|
| 40075 | 4 x 35 x 220 cm alb   |  | 20 |
| 40076 | 4 x 35 x 220 cm negru |  | 20 |

PLASA SARMA ZINCATA HEXAGONALA

Zn



| Nu.   | specificație              |   |
|-------|---------------------------|---|
| 42150 | 13   0,7 x 1000 mm - 50 m | 1 |
| 42151 | 16   0,7 x 1000 mm - 50 m | 1 |
| 42152 | 20   0,7 x 1000 mm - 50 m | 1 |
| 42153 | 25   0,8 x 1000 mm - 50 m | 1 |

PLASA SARMA ZINCATA HEXAGONALA

Zn



| Nu.   | specificație              |   |
|-------|---------------------------|---|
| 42155 | 13   0,7 x 1000 mm - 50 m | 1 |
| 42156 | 16   0,7 x 1000 mm - 50 m | 1 |
| 42157 | 20   0,7 x 1000 mm - 50 m | 1 |
| 42158 | 25   0,8 x 1000 mm - 50 m | 1 |

PLASA SARMA HEXAGONALA

Zn



| Nu.   | specificație            |   |
|-------|-------------------------|---|
| 42160 | 13   1 x 1000 mm - 25 m | 1 |
| 42161 | 16   1 x 1000 mm - 25 m | 1 |
| 42162 | 20   1 x 1000 mm - 25 m | 1 |
| 42163 | 25   1 x 1000 mm - 25 m | 1 |

PLASA GARD PVC



| Nu.   | eye size  | Ø sârmă | înălțimea | length |   |
|-------|-----------|---------|-----------|--------|---|
| 42175 | 15 x 9 mm | 2 mm    | 40 cm     | 25 m   | 1 |
| 42176 | 15 x 9 mm | 2 mm    | 65 cm     | 25 m   | 1 |
| 42177 | 15 x 9 mm | 2 mm    | 90 cm     | 25 m   | 1 |
| 42178 | 15 x 9 mm | 2 mm    | 120 cm    | 25 m   | 1 |
| 42179 | 15 x 9 mm | 2 mm    | 25 cm     | 25 m   | 1 |



## PLASA SARMA RECTANGULARA ZN

140  
g/m<sup>2</sup> 

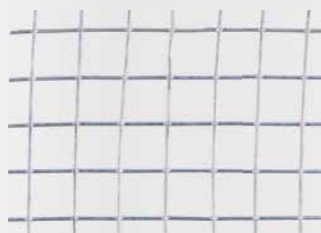

| Nu.   | specificație              | Nu.   | specificație               |
|-------|---------------------------|-------|----------------------------|
| 42185 | 6   0,65 x 1000 mm - 25 m | 42174 | 25   1,4 x 1000 mm - 25 m  |
| 42170 | 10   0,8 x 100 mm - 25 m  | 42186 | 13   1,05 x 1000 mm - 25 m |
| 42171 | 13   0,8 x 1000 mm - 25 m | 42187 | 25   2,0 x 1000 mm - 25 m  |
| 42172 | 16   1,2 x 1000 mm - 25 m | 42188 | 50   2,0 x 1000 mm - 25 m  |
| 42173 | 19   1,4 x 1000 mm - 25 m |       |                            |

## PLASA GARD PATRATE, PVC

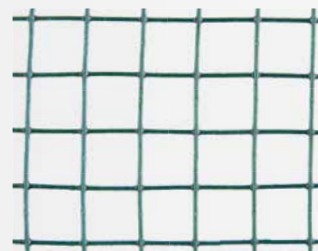

| Nu.   | specificație              |   |
|-------|---------------------------|---|
| 42180 | 13   1,2 x 1000 mm - 25 m | 1 |
| 42181 | 16   1,2 x 1000 mm - 25 m | 1 |
| 42182 | 25   2,3 x 1000 mm - 25 m | 1 |

## NET DE PĂȘĂRILE

MADE IN  
EU



| Nu.   | specificație        |    |
|-------|---------------------|----|
| 45570 | 2 x 5 m 18 x 18 mm  | 45 |
| 45571 | 2 x 10 m 18 x 18 mm | 28 |
| 45572 | 4 x 5 m 18 x 18 mm  | 24 |
| 45573 | 4 x 10 m 18 x 18 mm | 15 |

## PLASA PLASTIC

140  
g/m<sup>2</sup> 

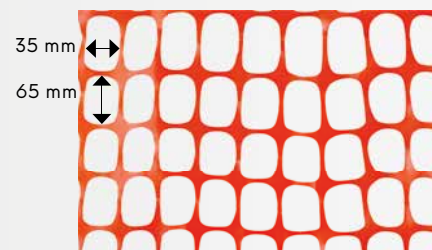

| Nu.   | specificație                        |   |
|-------|-------------------------------------|---|
| 42190 | 1,2 x 50 m HDPE 140g/m <sup>2</sup> | 1 |

## PLASA RABICO

Zn 



| Nu.   | specificație            |   |
|-------|-------------------------|---|
| 42312 | 1 m   50 bm, 16 x 16 mm | 1 |

## PROTECȚIE POMI CONTRA ROADERII

Önzáró | Auto-blocare

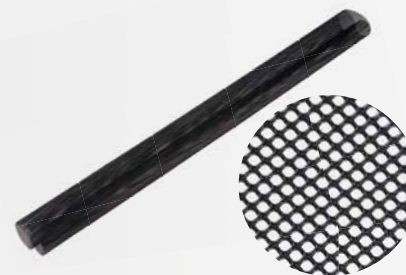

| Nu.   | specificație |   |
|-------|--------------|---|
| 45580 | Ø 11 x 80 cm | 1 |



SARMA

Zn

| Nu.   | Ø sârmă | lungimea firului |    |
|-------|---------|------------------|----|
| 42203 | 0,6 mm  | 30 m             | 50 |

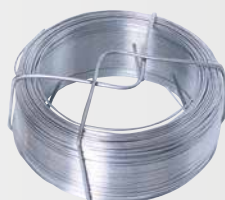

SARMA ZINCATA

Zn

| Nu.   | Ø sârmă | lungimea firului |    |
|-------|---------|------------------|----|
| 42207 | 0,8 mm  | 50 m             | 40 |
| 42208 | 0,8 mm  | 100 m            | 20 |
| 42209 | 0,9 mm  | 100 m            | 20 |
| 42240 | 1,0 mm  | 50 m             | 40 |
| 42210 | 1,0 mm  | 100 m            | 20 |
| 42211 | 1,2 mm  | 50 m             | 40 |
| 42212 | 1,2 mm  | 100 m            | 20 |
| 42213 | 1,4 mm  | 30 m             | 40 |
| 42214 | 1,4 mm  | 50 m             | 20 |
| 42217 | 1,8 mm  | 30 m             | 40 |
| 42218 | 1,8 mm  | 50 m             | 20 |



SARMA ZINCATA

Zn

| Nu.   | Ø sârmă | lungimea firului |    |
|-------|---------|------------------|----|
| 42219 | 2,0 mm  | 26 m             | 20 |
| 42220 | 2,0 mm  | 52 m             | 20 |
| 42221 | 2,0 mm  | 78 m             | 20 |
| 42228 | 3,15 mm | 26 m             | 10 |
| 42229 | 3,15 mm | 52 m             | 10 |
| 42230 | 3,15 mm | 78 m             | 10 |



SARMA

| Nu.   | Ø sârmă | lungimea firului | Suprafață |    |
|-------|---------|------------------|-----------|----|
| 42201 | 0,6 mm  | 30 m             | PVC       | 50 |
| 42202 | 0,9 mm  | 30 m             | PVC       | 50 |



SARMA INVELITA IN PVC

| Nu.   | Ø sârmă | lungimea firului |    |
|-------|---------|------------------|----|
| 42244 | 1,4 mm  | 50 m             | 20 |
| 42248 | 1,8 mm  | 50 m             | 20 |
| 42249 | 2,0 mm  | 50 m             | 20 |



SARMA INVELITA IN PVC

| Nu.   | Ø sârmă | lungimea firului |    |
|-------|---------|------------------|----|
| 42251 | 2,6 mm  | 26 m             | 20 |
| 42252 | 2,6 mm  | 52 m             | 20 |
| 42253 | 2,6 mm  | 78 m             | 20 |
| 42255 | 3,4 mm  | 26 m             | 10 |
| 42256 | 3,4 mm  | 52 m             | 10 |
| 42257 | 3,4 mm  | 78 m             | 10 |



SARMĂ GHIMPATĂ

Zn

| Nu.   | Ø sârmă | lungimea firului |   |
|-------|---------|------------------|---|
| 42260 | 1,7 mm  | 50 m             | 1 |
| 42261 | 1,7 mm  | 100 m            | 1 |



CLEMA PRINDERE CABLURI



CLEMA PRINDERE CABLURI



CRIC FIXARE CHINGI

| Nu.   | specificație |   |
|-------|--------------|---|
| 50035 | 2 t          | 6 |
| 50036 | 4 t          | 4 |

INOX

| Nu.   | specificație |    |
|-------|--------------|----|
| 50040 | verde        | 50 |
| 50041 | negru        | 50 |

MOQ 50

10x

| Nu.   | specificație |    |
|-------|--------------|----|
| 50042 |              | 10 |



INTINZATOR DE CABLURI

Zn

| Nu.   | specificație            |    |
|-------|-------------------------|----|
| 50030 | Zincare usoara          | 50 |
| 50032 | acoperire usoara cu PVC | 50 |



INTINZATOR DE CABLURI

Zn

| Nu.   | specificație        |    |
|-------|---------------------|----|
| 50031 | Zincare masiva      | 50 |
| 50033 | acoperire masiva cu | 50 |



INTINZATOR DE CABLURI

Zn

| Nu.   | specificație            |    |
|-------|-------------------------|----|
| 50037 | Zincare usoara          | 50 |
| 50038 | acoperire usoara cu PVC | 50 |

## ANCORE PENTRU TIJA

Zn

| Nu.   | specificație | tl.    |         |
|-------|--------------|--------|---------|
| 55436 | 70 x 75 mm   | 110 mm | 4 mm 10 |
| 55437 | 80 x 90 mm   | 130 mm | 4 mm 10 |



## ANCORE PENTRU TIJA

Zn

| Nu.   | specificație | tl.    |         |
|-------|--------------|--------|---------|
| 55429 | 70 x 60 mm   | 100 mm | 4 mm 10 |
| 55433 | 81 x 60 mm   | 100 mm | 4 mm 10 |
| 55430 | 91 x 60 mm   | 100 mm | 4 mm 10 |
| 55431 | 101 x 60 mm  | 100 mm | 4 mm 10 |
| 55432 | 121 x 60 mm  | 100 mm | 4 mm 10 |



## PICIOR DE ANCORARE A COLOANEI REGLABIL

Zn

| Nu.   | Specificație     | tl.    |        |
|-------|------------------|--------|--------|
| 55465 | 80 - 160 x 70 mm | 100 mm | 4 mm 1 |

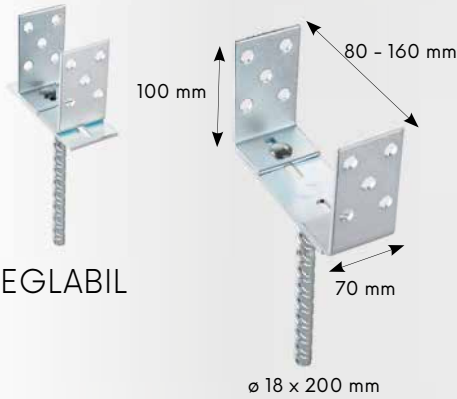

## TARUS METALIC ZN

Zn

| Nu.   | Ø ancora     | lungime ancora | material thickness |   |
|-------|--------------|----------------|--------------------|---|
| 55420 | 71 x 71 mm   | 150 mm         | 2 mm               | 1 |
| 55425 | 81 x 81 mm   | 150 mm         | 2 mm               | 1 |
| 55421 | 91 x 91 mm   | 150 mm         | 2 mm               | 1 |
| 55422 | 101 x 101 mm | 150 mm         | 2 mm               | 1 |
| 55423 | 121 x 121 mm | 150 mm         | 2 mm               | 1 |
| 55424 | 151 x 151 mm | 150 mm         | 2 mm               | 1 |



## BURGHIU DE SOL

| Nu.   | Ø      | A      | B       |   |
|-------|--------|--------|---------|---|
| 61299 | 110 mm | 270 mm | 1200 mm | 1 |
| 61300 | 140 mm | 270 mm | 1200 mm | 1 |
| 61301 | 170 mm | 270 mm | 1200 mm | 1 |
| 61302 | 200 mm | 270 mm | 1200 mm | 1 |



## STÂLP REGLABILĂ CU ȘURUB

Zn

| Nu.   | Ø ancora     | înălțimea ancora | fir |    |
|-------|--------------|------------------|-----|----|
| 55460 | 80 x 80 mm   | 150 mm           | M16 | 10 |
| 55461 | 100 x 100 mm | 150 mm           | M16 | 10 |
| 55462 | 150 x 150 mm | 150 mm           | M24 | 10 |



## TARUS METALIC

Zn

| Nu.   | Ø ancora     | lungime ancora | material thickness |   |
|-------|--------------|----------------|--------------------|---|
| 55400 | 71 x 71 mm   | 750 mm         | 2 mm               | 1 |
| 55401 | 91 x 91 mm   | 750 mm         | 2 mm               | 1 |
| 55406 | 81 x 81 mm   | 750 mm         | 2 mm               | 1 |
| 55402 | 91 x 91 mm   | 900 mm         | 2 mm               | 1 |
| 55403 | 101 x 101 mm | 900 mm         | 2 mm               | 1 |
| 55404 | 121 x 121 mm | 900 mm         | 2 mm               | 1 |
| 55405 | 151 x 151 mm | 900 mm         | 2 mm               | 1 |



## KIT UNIVERSAL ANCORARE

Zn

| Nu.   | Ø ancora    | lungime ancora | material thickness |   |
|-------|-------------|----------------|--------------------|---|
| 55455 | 71 x 60 mm  | 100 mm         | 4 mm               | 1 |
| 55452 | 81 x 60 mm  | 100 mm         | 4 mm               | 1 |
| 55456 | 90 x 60 mm  | 100 mm         | 4 mm               | 1 |
| 55453 | 101 x 60 mm | 100 mm         | 4 mm               | 1 |
| 55457 | 110 x 60 mm | 100 mm         | 4 mm               | 1 |
| 55454 | 121 x 60 mm | 100 mm         | 4 mm               | 1 |

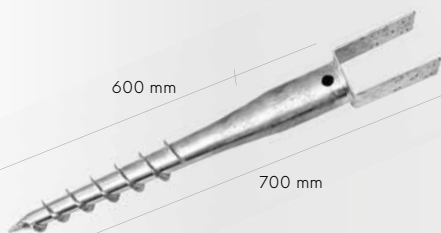

## KIT UNIVERSAL ANCORARE

reducere

Ø 24 mm  
Ø 35 mm  
Ø 40 mm  
Ø 48 mm  
Ø 55 mm

Zn 6x

| Nu.   | Ø ancora | lungime ancora | specificație        |   |
|-------|----------|----------------|---------------------|---|
| 55450 | 60 mm    | 550 mm         | 1 buc + 5x reducere | 8 |



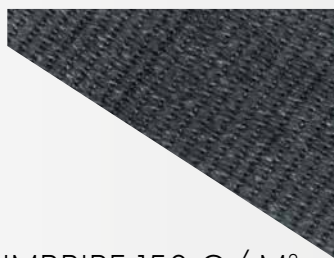

**PLASA UMBRIRE 150 G/ M<sup>2</sup> ANTRACIT**

· protecție 85%



| Nu.   | specificație |   |
|-------|--------------|---|
| 45496 | 1 x 10 m     | 1 |
| 45497 | 1,5 x 10 m   | 1 |
| 45498 | 1,8 x 10 m   | 1 |
| 45499 | 2 x 10 m     | 1 |

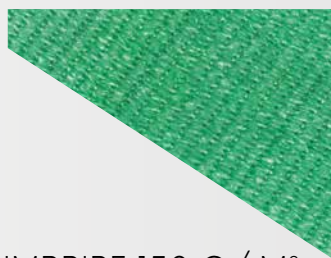

**PLASA UMBRIRE 150 G/ M<sup>2</sup>**

· protecție 85%



| Nu.   | specificație |   |
|-------|--------------|---|
| 45460 | 1 x 10 m     | 1 |
| 45461 | 1,5 x 10 m   | 1 |
| 45463 | 1,8 x 10 m   | 1 |
| 45462 | 2 x 10 m     | 1 |



**PLASA UMBRIRE 220 G/ M<sup>2</sup>**

· protecție 95%



| Nu.   | specificație |   |
|-------|--------------|---|
| 45465 | 1 x 10 m     | 1 |
| 45466 | 1,5 x 10 m   | 1 |
| 45467 | 2 x 10 m     | 1 |

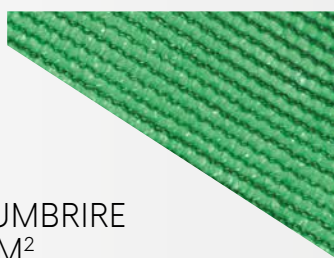

**PLASA UMBRIRE 80 G/ M<sup>2</sup>**



| Nu.   | specificație |   |
|-------|--------------|---|
| 45450 | 1 x 10 m     | 1 |
| 45451 | 1,5 x 10 m   | 1 |
| 45453 | 1,8 x 10 m   | 1 |
| 45452 | 2 x 10 m     | 1 |

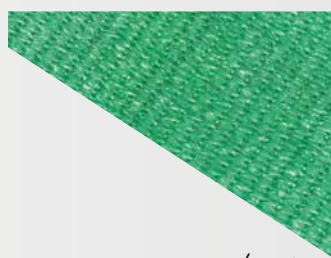

**PLASA UMBRIRE 150 G/ M<sup>2</sup>**

· protecție 85%

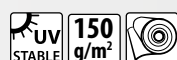

| Nu.   | specificație |   |
|-------|--------------|---|
| 45480 | 1,5 x 50 m   | 1 |

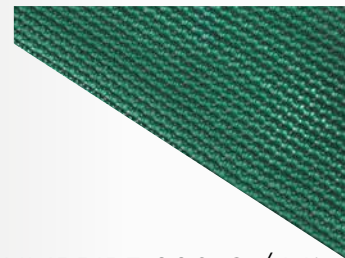

**PLASA UMBRIRE 220 G/ M<sup>2</sup>**

· protecție 95%

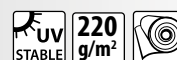

| Nu.   | specificație |   |
|-------|--------------|---|
| 45485 | 1,5 x 50 m   | 1 |



**BRIDE PLASTIC**

· EN 50146  
· nylon



| Nu.   | specificație  |   |
|-------|---------------|---|
| 23875 | 120 mm 4,8 mm | 1 |



| Nu.   | specificație |   |
|-------|--------------|---|
| 45470 |              | 1 |



**CLEMĂ PRINDERE PLASA UMBRIRE**

**SET BARBECUE**

|             |              |   |
|-------------|--------------|---|
| <b>INOX</b> | <b>18x</b>   |   |
| Nu.         | specificație |   |
| 43077       |              | 6 |

**SET BARBECUE**

|             |              |    |
|-------------|--------------|----|
| <b>INOX</b> | <b>3x</b>    |    |
| Nu.         | specificație |    |
| 43071       | 380 mm       | 16 |

**BARBECUE CLESTE**

|             |              |    |
|-------------|--------------|----|
| <b>INOX</b> |              |    |
| Nu.         | specificație |    |
| 43072       | 360 mm       | 25 |

**FARFURIE GRILL ALU**

|           |              |    |
|-----------|--------------|----|
| <b>4x</b> |              |    |
| Nu.       | specificație |    |
| 43050     | 300 x 200 mm | 50 |

**GRATAR**

|       |              |    |
|-------|--------------|----|
| Nu.   | specificație |    |
| 43084 | 330 x 290 mm | 50 |

**GRATAR PENTRU PESTE**

|       |              |    |
|-------|--------------|----|
| Nu.   | specificație |    |
| 43082 | 280 x 276 mm | 50 |

**GRILL**

|       |              |    |
|-------|--------------|----|
| Nu.   | specificație |    |
| 43058 | 58 x 30 mm   | 20 |
| 43060 | 60 x 40 mm   | 20 |
| 43068 | 68 x 40 mm   | 16 |

**GRATAR PENTRU PESTE**

|       |              |    |
|-------|--------------|----|
| Nu.   | specificație |    |
| 43083 | 360 x 130 mm | 12 |

**TIJE FRIGARUI**

|           |              |    |
|-----------|--------------|----|
| <b>4x</b> |              |    |
| Nu.       | specificație |    |
| 43086     | ∅ 3 x 380 mm | 80 |

**GRILL TIJA**  
\* cu aprobare igienică

|       |              |     |
|-------|--------------|-----|
| Nu.   | specificație |     |
| 43097 | 100 cm       | 100 |





285 - 900 mm

FURCĂ GRĂȚAR - TELESCOPICĂ

INOX



Nu. specificație  
43094

1



COMPRESOR



Nu. specificație  
43087

1



PERIE BARBECUE

Nu. specificație  
43098 30 cm

10



PERIE 3 IN 1

Nu. specificație  
43099

40



COMPRESOR PENTRU GRATAR 230V

CE



Nu. specificație  
43090

24



COMPRESOR PENTRU GRATAR

· battery type D



Nu. specificație  
43089

48



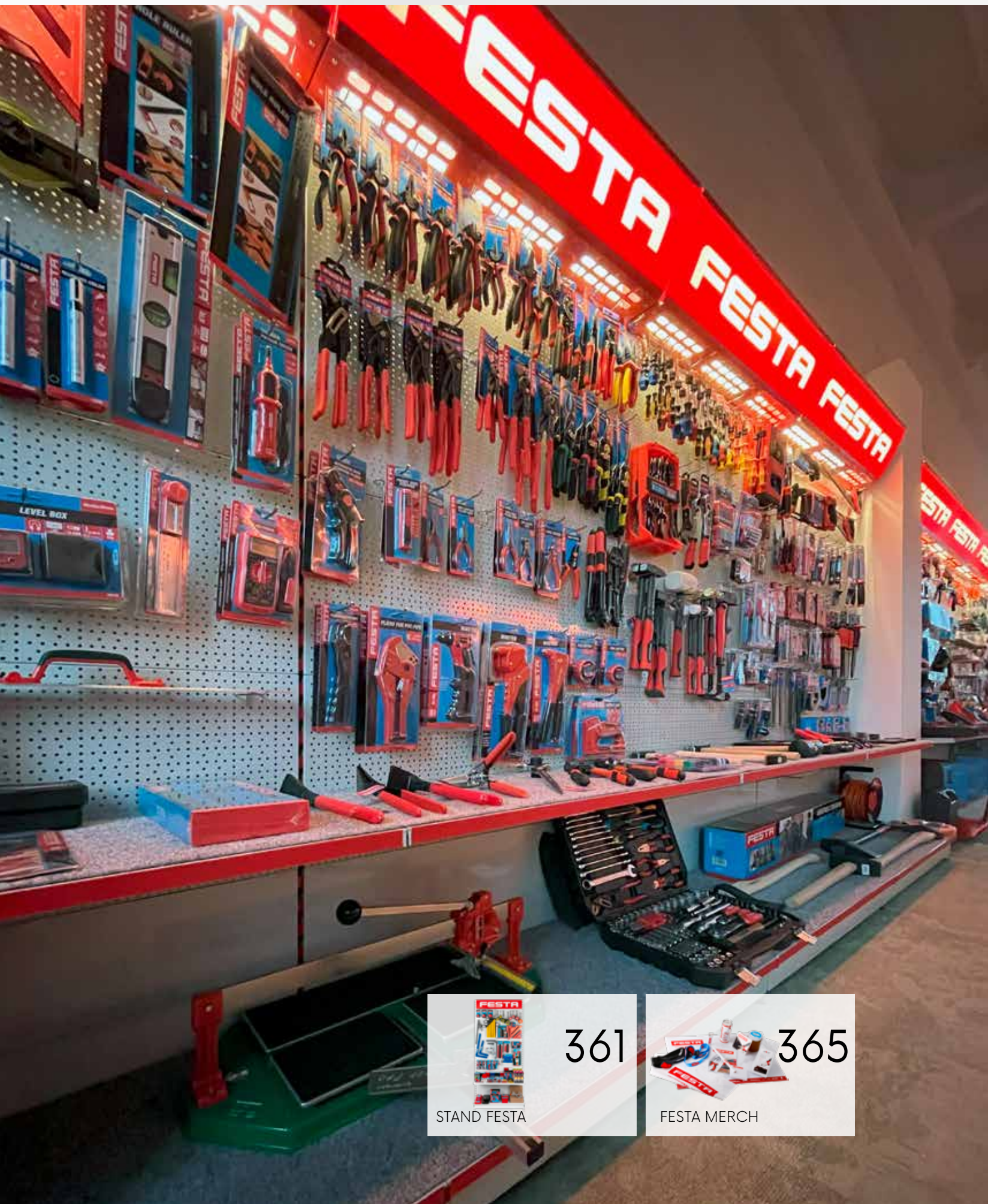

361

STAND FESTA



365

FESTA MERCH



 STAND FESTA ECHIPAT

**FESTA**

CASETĂ LUMINOASĂ PENTRU STAND FESTA 81011

| Nu.   | specificație      |  |
|-------|-------------------|---|
| 81195 | FESTA POWER TOOLS | 1   |
| 81196 | FESTA             | 1   |
| 81197 | FESTA INDUSTRY    | 1   |



**STAND FESTA**



| Nu.    | specificație                      |  |
|--------|-----------------------------------|---|
| 81011  | stand FESTA CZ 200 x 100 cm       | 1   |
| 81011A | stand 81011 + autocolant AQUATIC  | 1   |
| 81011F | stand 81011 + autocolant FESTA CZ | 1   |
| 81011G | stand 81011 + autocolant FESTA GB | 1   |
| 81011H | stand 81011 + autocolant FESTA SK | 1   |
| 81011R | stand 81011 + autocolant ROSA     | 1   |
| 81012  | polc fehér CZ adâncime 40         | 8   |
| 81013  | cârlig 10 cm                      | 10  |
| 81014  | cârlig 16 cm                      | 10  |
| 81015  | cârlig 20 cm                      | 10  |
| 81035  | cârlig 20 cm                      | 10  |
| 81016  | cârlig 30 cm                      | 10  |
| 81036  | cârlig 30 cm                      | 10  |
| 81022  | coș de sârmă - mare               | 1   |
| 81023  | coș de sârmă - mic                | 1   |
| 81024  | partiție - mare                   | 1   |
| 81025  | partiție - mică                   | 1   |

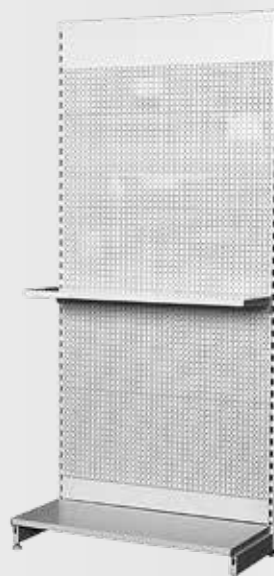



## TRADE BRACKET

· compatibil cu suportul FESTA

| Nu.   | specificație        |  |
|-------|---------------------|---|
| 81150 | 1000 x 50 x 135 mm  | 1   |
| 81151 | 1000 x 150 x 135 mm | 1   |
| 81152 | 1000 x 350 x 135 mm | 1   |

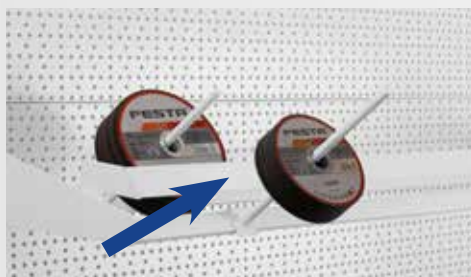

## PRICE HOLDER

· compatibil cu suportul FESTA

| Nu.   | specificație       |  |
|-------|--------------------|---|
| 81155 | 1000 x 80 x 100 mm | 1   |



## HOOK FOR CUTTING DISCS

· compatibil cu suportul FESTA

| Nu.   | specificație |  |
|-------|--------------|---|
| 81186 | 150 mm       | 1   |
| 81185 | 250 mm       | 1   |



## FRAME FOR CUTTING DISCS

· compatibil cu suportul FESTA

| Nu.   | specificație       |  |
|-------|--------------------|---|
| 81170 | 1000 x 450 x 85 mm | 1   |



## SUPT FERASTRAU

· compatibil cu suportul FESTA

| Nu.   | specificație |  |
|-------|--------------|---|
| 81190 |              | 1   |



## CÂRLIG PENTRU UNELTE FĂRĂ FIR

· compatibil cu suportul FESTA

| Nu.   | specificație |  |
|-------|--------------|---|
| 81189 |              | 1   |



## SUPT DISCURI

· compatibil cu suportul FESTA

| Nu.   | specificație       |  |
|-------|--------------------|---|
| 81191 | 220 x 220 x 200 mm | 1   |

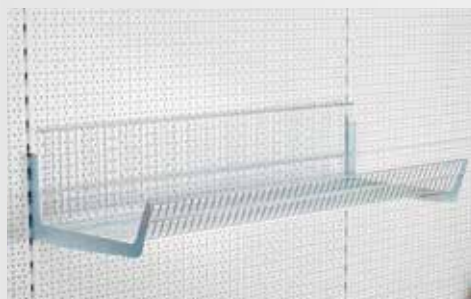

## COȘ

· compatibil cu suportul FESTA

| Nu.   | specificație        |  |
|-------|---------------------|---|
| 81160 | 1000 x 470 x 180 mm | 1   |



## DIVIDER

· compatibil cu suportul FESTA

| Nu.   | specificație |  |
|-------|--------------|---|
| 81165 | 470 x 180 mm | 1   |



## SUPT PENTRU CIOCANE

Zn

· compatibil cu suportul FESTA

| Nu.   | specificație |  |
|-------|--------------|---|
| 81188 | max 2 kg     | 1   |



## CARLIG

· compatibil cu suportul FESTA

| Nu.   | specificație |  |
|-------|--------------|---|
| 81175 | 120 mm       | 1   |
| 81178 | 180 mm       | 1   |



## CARLIG

· compatibil cu suportul FESTA

| Nu.   | specificație |  |
|-------|--------------|---|
| 81180 | 120 mm       | 1   |



| Nu.   | specificație                       |   |
|-------|------------------------------------|---|
| 81200 | Picior 40/2400 mm kotvená          | 1 |
| 81201 | Picior 80/1108 mm                  | 1 |
| 81202 | Picior 80/1208 mm                  | 1 |
| 81203 | Picior 80/1408 mm                  | 1 |
| 81204 | Picior 80/1608 mm                  | 1 |
| 81205 | Picior 80/1808 mm                  | 1 |
| 81206 | Picior 80/2000 mm                  | 1 |
| 81207 | Picior 80/2108 mm                  | 1 |
| 81208 | Picior 80/2208 mm                  | 1 |
| 81209 | Picior 80/2308 mm                  | 1 |
| 81210 | Picior 80/2408 mm                  | 1 |
| 81211 | Picior 80/2600 mm                  | 1 |
| 81212 | Picior 60/1000 mm                  | 1 |
| 81213 | Picior 60/1208 mm                  | 1 |
| 81214 | Picior 60/1408 mm                  | 1 |
| 81215 | Picior 60/1608 mm                  | 1 |
| 81216 | Picior 60/1808 mm                  | 1 |
| 81217 | Picior 60/2108 mm                  | 1 |
| 81218 | Picior 60/2208 mm                  | 1 |
| 81225 | Picior 30/2108 mm přední           | 1 |
| 81486 | Picior 60/2000 mm                  | 1 |
| 81219 | Alonjă picior 80x30/100mm          | 1 |
| 81220 | Alonjă picior 80x30/400 mm         | 1 |
| 81221 | Alonjă picior 80x30/600 mm         | 1 |
| 81222 | Alonjă picior 60x30/400 mm         | 1 |
| 81223 | Picior colțar 90st. 2100mm         | 1 |
| 81224 | Picior colțar 90st. 2200mm         | 1 |
| 81226 | Contrafort 80                      | 1 |
| 81227 | Contrafort 60                      | 1 |
| 81228 | Manșon gondolă cu raft 80          | 1 |
| 81229 | Bară ancorare                      | 1 |
| 81230 | Cârlig ancorare                    | 1 |
| 81231 | Sistem ancorare ușoară             | 1 |
| 81232 | Sistem ancorare superioară         | 1 |
| 81233 | Tăblie 400                         | 1 |
| 81234 | Tăblie 500                         | 1 |
| 81235 | Tăblie 600                         | 1 |
| 81236 | Tăblie 700                         | 1 |
| 81237 | Tăblie 800                         | 1 |
| 81238 | Consolă joasă 200                  | 1 |
| 81239 | Consolă joasă 300                  | 1 |
| 81240 | Consolă joasă 400                  | 1 |
| 81241 | Consolă joasă 500                  | 1 |
| 81242 | Consolă înaltă 400                 | 1 |
| 81243 | Consolă înaltă 500                 | 1 |
| 81244 | Consolă înaltă 600                 | 1 |
| 81245 | Consolă înaltă 700                 | 1 |
| 81246 | Consolă joasă 300 dublă            | 1 |
| 81247 | Consolă joasă 400 dublă            | 1 |
| 81248 | Consolă joasă 300 dublă            | 1 |
| 81251 | Consolă RR 80                      | 1 |
| 81249 | Consolă înaltă dublă 500           | 1 |
| 81250 | Grindă vitrină înaltă 400/2000     | 1 |
| 81252 | Piesă de separare raft tip igheab  | 1 |
| 81253 | Piesă de separare joasă 300        | 1 |
| 81254 | Piesă de separare joasă 400        | 1 |
| 81255 | Piesă de separare joasă 500        | 1 |
| 81256 | Piesă de separare joasă 300 sticlă | 1 |
| 81257 | Piesă de separare joasă 400 sticlă | 1 |
| 81258 | Piesă de separare joasă 500 sticlă | 1 |
| 81259 | Piesă de separare 300 sticlă       | 1 |
| 81262 | Piesă de separare 300 plexi        | 1 |
| 81263 | Piesă de separare 400 plexi        | 1 |
| 81264 | Piesă de separare 500 plexi        | 1 |
| 81260 | Piesă de separare 400 sticlă       | 1 |
| 81261 | Piesă de separare 500 sticlă       | 1 |
| 81265 | Laterală vitrină înaltă 400/2000   | 1 |
| 81266 | Flanc streășină RR 80              | 1 |
| 81267 | Flanc alimentator 500mm            | 1 |
| 81268 | Flanc vitrină 500                  | 1 |
| 81269 | Grindă superioară 500 vit.         | 1 |
| 81271 | Laterală raft joasă 300 plast      | 1 |
| 81272 | Laterală raft joasă 400 plast      | 1 |
| 81273 | Laterală raft joasă 500 plast      | 1 |
| 81274 | Flanc înalt sticlă 300/250         | 1 |
| 81275 | Bușon flanc                        | 1 |
| 81276 | Flanc înalt sticlă üveg 500/250    | 1 |
| 81277 | Flanc înalt sticlă 400             | 1 |
| 81278 | Flanc înalt sticlă 500             | 1 |
| 81270 | Grindă streășină RR 80             | 1 |
| 81279 | Grindă streășină                   | 1 |
| 81280 | Flanc streășină Stâng              | 1 |
| 81281 | Flanc streășină Drept              | 1 |
| 81282 | Braț ancorare                      | 1 |
| 81284 | Braț dublă 400/10                  | 1 |
| 81285 | Braț dublă 300/8                   | 1 |
| 81286 | Braț 350                           | 1 |
| 81287 | Braț 500                           | 1 |
| 81288 | Braț 250                           | 1 |
| 81289 | Ancorare dublă 100                 | 1 |
| 81290 | Ancorare dublă 200                 | 1 |
| 81291 | Ancorare dublă 300                 | 1 |
| 81292 | Ancorare 130 V                     | 1 |

| Nu.   | specificație                              |   |
|-------|---|---|
| 81293 | Ancorare 100                              | 1 |
| 81294 | Ancorare 200                              | 1 |
| 81295 | Ancorare 300                              | 1 |
| 81296 | Hook cu suport 200                        | 1 |
| 81297 | Hook cu suport 300                        | 1 |
| 81298 | Blocare de afisare de sticla              | 1 |
| 81299 | Piesă separare raft sârmă 360mm înaltă    | 1 |
| 81300 | Piesă separare raft sârmă 460 mm înaltă   | 1 |
| 81301 | Piesă separare raft sârmă 560 mm înaltă   | 1 |
| 81302 | Piesă separare raft sârmă 560 mm joasă    | 1 |
| 81303 | Consolă 300 dublă L                       | 1 |
| 81304 | Consolă 300 dublă P                       | 1 |
| 81305 | Consolă 400 dublă L                       | 1 |
| 81306 | Consolă 400 dublă P                       | 1 |
| 81307 | Consolă 500 dublă L                       | 1 |
| 81308 | Consolă 500 dublă P                       | 1 |
| 81309 | Raft semicerc 300                         | 1 |
| 81310 | Raft semicerc 400                         | 1 |
| 81311 | Raft semicerc 500                         | 1 |
| 81312 | Socl semicerc 500                         | 1 |
| 81313 | Front soclu semicerc 500                  | 1 |
| 81314 | Suport preț 300 semicerc                  | 1 |
| 81315 | Suport preț 400 semicerc                  | 1 |
| 81316 | Suport preț 500 semicerc                  | 1 |
| 81317 | Raft semicerc 600                         | 1 |
| 81318 | Socl semicerc 600                         | 1 |
| 81319 | Front soclu semicerc 600                  | 1 |
| 81320 | Preț P 7,5x5 cm                           | 1 |
| 81321 | Preț P 2,6x3,2 cm                         | 1 |
| 81322 | Preț P 5,0x4,0 cm                         | 1 |
| 81323 | Raft găurit 500/1000                      | 1 |
| 81324 | Coroborat cu picior 80, modul 1           | 1 |
| 81325 | Panou spate 10x100cm                      | 1 |
| 81326 | Panou spate 20x100cm                      | 1 |
| 81327 | Panou spate 40x100cm                      | 1 |
| 81328 | Panou spate perf. 20x100 cm EUR           | 1 |
| 81329 | Panou spate perf. 40x100 cm EUR           | 1 |
| 81330 | Capac gondole 8x100cm                     | 1 |
| 81331 | Capac gondole 6x100cm                     | 1 |
| 81332 | Sprijin braț 100cm                        | 1 |
| 81333 | Raft sticlă 985/300 vitrina               | 1 |
| 81334 | Raft sticlă 985/400 vitrina               | 1 |
| 81335 | Raft lemn 47/98,5                         | 1 |
| 81336 | Raft sârmă 1000/500                       | 1 |
| 81337 | Raft adânc 1000x500                       | 1 |
| 81338 | Raft 200/1000                             | 1 |
| 81339 | Raft 300/1000                             | 1 |
| 81340 | Raft 400/1000                             | 1 |
| 81341 | Raft 500/1000                             | 1 |
| 81342 | Raft 400/1000 RAL7015                     | 1 |
| 81343 | Raft 500/1000 RAL7015                     | 1 |
| 81347 | Cadru cu înaltă afișă 1000/400            | 1 |
| 81348 | Sticlă cadru cu înaltă afișă 1000/400     | 1 |
| 81349 | Sertar                                    | 1 |
| 81350 | Plafon de raft metalic 500/100            | 1 |
| 81352 | Contrafort frontal înaltă 1000 mm, sticlă | 1 |
| 81353 | Contrafort frontal înaltă, plexi          | 1 |
| 81354 | Contrafort frontal joasă 1000 mm, plast   | 1 |
| 81355 | Bandă pentru prețuri, 1000mm              | 1 |
| 81356 | Coamă                                     | 1 |
| 81351 | Coamă cu înalt piesă separare, 1000       | 1 |
| 81357 | Coamă, 1000 mm                            | 1 |
| 81403 | Coamă cu înalt piesă separare, 1250 mm    | 1 |
| 81420 | Coamă cu înalt piesă separare, 625 mm     | 1 |
| 81358 | Dublă canelură cu ușă afișă               | 1 |
| 81359 | Suport preț, 1000mm                       | 1 |
| 81360 | Ușă display 1000/2000                     | 1 |
| 81361 | Front streășină, 1000mm                   | 1 |
| 81362 | Placă streășină, 1000mm                   | 1 |
| 81363 | Ușă magazie                               | 1 |
| 81364 | Ușă glisantă                              | 1 |
| 81365 | Oglindă cu afișă                          | 1 |
| 81366 | Ancorare cadru, modul 1                   | 1 |
| 81367 | Ancorare pol                              | 1 |
| 81370 | Coș de sârmă oblic                        | 1 |
| 81371 | Tejghea cu tăblie plină 1000mm            | 1 |
| 81372 | Soclu tejghea SU 5 1000mm                 | 1 |
| 81373 | Tejghea cu geam 1000mm                    | 1 |
| 81374 | Tejghea cu placă inox 1000mm              | 1 |
| 81375 | Tejghea cu tăblie plină 600mm             | 1 |
| 81376 | Raft tejghea 600mm                        | 1 |
| 81377 | Tejghea cu geam 600mm                     | 1 |
| 81378 | Raft tejghea 1000mm                       | 1 |
| 81379 | Raft tejghea lung                         | 1 |
| 81380 | Segment tejghea înalt 90°                 | 1 |
| 81381 | Falț dublu tejghea 1000 pereche           | 1 |
| 81382 | Ușă glisantă, tejghea 1000, pereche       | 1 |
| 81383 | Priză sub tejghea                         | 1 |
| 81384 | Raft sârmă RDE 1000/360mm                 | 1 |
| 81385 | Raft sârmă RDE 1000/460mm                 | 1 |
| 81386 | Raft sârmă RDE 1000/560mm                 | 1 |
| 81387 | Bandă pentru prețuri RDE 1000 mm          | 1 |
| 81388 | Panou spate 100/1250mm plin               | 1 |

| Nu.   | specificație                               |   |
|-------|--|---|
| 81389 | Panou spate 200/1250mm plin                | 1 |
| 81390 | Panou spate 400/1250mm plin                | 1 |
| 81391 | Panou spate 200/1250mm perf.               | 1 |
| 81393 | Capac gondolă 80/1250mm                    | 1 |
| 81392 | Panou spate 400/1250mm perf.               | 1 |
| 81394 | Capac gondolă 60/1250mm                    | 1 |
| 81395 | Grindă ancore 1250mm                       | 1 |
| 81396 | Raft 200/1250mm                            | 1 |
| 81439 | Grindă ancore 1000 mm                      | 1 |
| 81344 | Raft 300/1000 întărit                      | 1 |
| 81345 | Raft 400/1000 întărit                      | 1 |
| 81346 | Raft 500/1000 întărit                      | 1 |
| 81397 | Raft 300/1250mm                            | 1 |
| 81400 | Raft 300/1250mm, întărit                   | 1 |
| 81401 | Raft 400/1250mm, întărit                   | 1 |
| 81402 | Raft 500/1250mm, întărit                   | 1 |
| 81398 | Raft 400/1250mm                            | 1 |
| 81399 | Raft 500/1250mm                            | 1 |
| 81404 | Contrafort frontal jos 1250mm, plastic alb | 1 |
| 81405 | Bandă pentru prețuri, 1250 mm              | 1 |
| 81406 | Coamă 1250mm                               | 1 |
| 81407 | Suport preț, 1250mm                        | 1 |
| 81408 | Front streășină, 1250mm                    | 1 |
| 81409 | Placă streășină, 600x1250mm                | 1 |
| 81410 | Panou spate 100/625 plin                   | 1 |
| 81411 | Panou spate 200/625 plin                   | 1 |
| 81412 | Panou spate 400/625 plin                   | 1 |
| 81413 | Panou spate 400/625 perf.                  | 1 |
| 81414 | Capac gondolă 80/650                       | 1 |
| 81415 | Capac gondolă 60/650                       | 1 |
| 81416 | Grindă ancore, modul 3                     | 1 |
| 81432 | Grindă ancore, 1330mm                      | 1 |
| 81417 | Raft 300/625                               | 1 |
| 81418 | Raft 400/625                               | 1 |
| 81419 | Raft 500/625                               | 1 |
| 81421 | Contrafort frontal jos 625, plastic alb    | 1 |
| 81422 | Bandă pentru prețuri 625mm                 | 1 |
| 81423 | Coamă 625mm                                | 1 |
| 81424 | Suport preț, 625mm                         | 1 |
| 81425 | Panou spate 100/1330 plin                  | 1 |
| 81457 | Contrafort frontal jos 200 plastic         | 1 |
| 81426 | Panou spate 200/1330 plin                  | 1 |
| 81427 | Panou spate 400/1330 plin                  | 1 |
| 81428 | Panou spate 200/1330 perf. S               | 1 |
| 81429 | Panou spate 400/1330 perf. S               | 1 |
| 81430 | Capac gondole 80/1330                      | 1 |
| 81431 | Capac gondole 60/1330                      | 1 |
| 81433 | Raft 300/1330                              | 1 |
| 81434 | Raft 400/1330                              | 1 |
| 81435 | Raft 500/1330                              | 1 |
| 81436 | Bară pentru prețuri, 1330 mm               | 1 |
| 81437 | Coamă 1330 mm                              | 1 |
| 81438 | Suport preț 1330 mm                        | 1 |
| 81440 | Raft sârmă - coș                           | 1 |
| 81441 | Panou spate 100 colțar                     | 1 |
| 81442 | Panou spate 400 colțar                     | 1 |
| 81443 | Front soclu colțar 500/1000mm              | 1 |
| 81444 | Front soclu colțar 600 mm                  | 1 |
| 81445 | Panou spate colțar 400mm perf.             | 1 |
| 81447 | Raft 300 colțar                            | 1 |
| 81448 | Raft 400 colțar                            | 1 |
| 81449 | Raft 500 colțar                            | 1 |
| 81450 | Raft 600 colțar                            | 1 |
| 81451 | Suport preț 300 colțar                     | 1 |
| 81452 | Suport preț 400 colțar                     | 1 |
| 81453 | Suport preț 500 colțar                     | 1 |
| 81454 | Bară pentru prețuri 300 colțar             | 1 |
| 81455 | Bară pentru prețuri 400 colțar             | 1 |
| 81456 | Bară pentru prețuri 500 colțar             | 1 |
| 81458 | Raft sârmă coș U 1000/400                  | 1 |
| 81459 | Raft sârmă coș U 1000/500                  | 1 |
| 81460 | Front soclu colțar 90°                     | 1 |
| 81461 | Panou spate colțar 100, Picior 60          | 1 |
| 81462 | Panou spate colțar 200, Picior 60          | 1 |
| 81463 | Panou spate colțar 400, Picior 80          | 1 |
| 81466 | Panou spate colțar 100, Picior 80          | 1 |
| 81467 | Panou spate colțar 400, Picior 60          | 1 |
| 81468 | Raft colțar 90° 400mm                      | 1 |
| 81469 | Raft colțar 90° 500mm                      | 1 |
| 81470 | Suport preț colțar 90° 400mm               | 1 |
| 81471 | Suport preț colțar 90° 500mm               | 1 |
| 81472 | Bară pentru prețuri colțar 90° 400mm       | 1 |
| 81473 | Bară pentru prețuri colțar 90° 500mm       | 1 |



## CONSOLA ALB

MOQ  
2

| Nu.   | specificatie |    |
|-------|--------------|----|
| 81100 | 100 x 75 mm  | 24 |
| 81101 | 125 x 100 mm | 24 |
| 81102 | 150 x 125 mm | 24 |
| 81103 | 200 x 150 mm | 24 |
| 81104 | 250 x 200 mm | 24 |
| 81105 | 300 x 250 mm | 24 |
| 81106 | 350 x 300 mm | 24 |



## SUPORT VERTICAL

| Nu.   | specificatie |    |
|-------|--------------|----|
| 81053 | 50 cm        | 10 |
| 81054 | 80 cm        | 10 |
| 81057 | 200 cm       | 10 |



## CONSOLA CLICK

| Nu.   | specificatie |    |
|-------|--------------|----|
| 81070 | 10 cm        | 10 |
| 81071 | 15 cm        | 10 |
| 81077 | 50 cm        | 10 |



## STANDURI PREZENTARE PRODUSE DIN CARTON FOR LEVELING SYSTEMS



| Nu.   | specificatie           |   |
|-------|------------------------|---|
| 37179 | 60 x 40 x 175 cm - ENG | 1 |



## STANDURI PREZENTARE PRODUSE DIN CARTON



| Nu.   | specificatie           |   |
|-------|------------------------|---|
| 81602 | 60 x 40 x 175 cm - ENG | 1 |

## STANDURI PREZENTARE PRODUSE DIN CARTON FESTA POWER TOOLS



| Nu.   | specificatie     |   |
|-------|------------------|---|
| 81603 | 60 x 40 x 175 cm | 1 |



**FESTA**

BLOC DE PUBLICITATE FESTIVAL FESTA

| Nu.    | specificație |
|--------|--------------|
| M90400 |              |



1

**FESTA**

TRICOU PUBLICITAR ROȘU FESTA



| Nu.    | specificație |
|--------|--------------|
| M90203 | M            |
| M90204 | L            |
| M90205 | XL           |
| M90206 | XXL          |
| M90207 | XXXL         |



**FESTA**

STILOU PUBLICITAR FESTA

| Nu.    | specificație |
|--------|--------------|
| M90403 |              |



1



**FESTA**

CABLU USB DE PUBLICITATE FESTA

| Nu.    | specificație |
|--------|--------------|
| M90519 |              |



1

**FESTA**

CIORAPI PUBLICITARI FESTA



| Nu.    | specificație |
|--------|--------------|
| M90220 | 39-41        |
| M90221 | 42-44        |
| M90222 | 45-47        |



**FESTA**

CONTOR DE PUBLICITATE FESTA

| Nu.   | specificație |
|-------|--------------|
| 11410 | 2 m x 16 mm  |

MOQ  
12



1



**FESTA**

CAPAC PUBLICITAR FESTA



| Nu.    | specificație |
|--------|--------------|
| M90210 |              |

**FESTA**

CUȚIT PLIANT PUBLICITAR

| Nu.   | specificație |
|-------|--------------|
| 16209 |              |



1



| Cod produs | pagina | Cod produs | pagina | Cod produs | pagina | Cod produs | pagina | Cod produs | pagina | Cod produs | pagina |
|------------|--------|------------|--------|------------|--------|------------|--------|------------|--------|------------|--------|
| 10002      | 96     | 11355      | 98     | 13249      | 121    | 13414      | 101    | 13509      | 99     | 14420      | 104    |
| 10003      | 96     | 11356      | 98     | 13250      | 121    | 13415      | 101    | 13510      | 99     | 14421      | 104    |
| 10005      | 96     | 11358      | 98     | 13251      | 121    | 13416      | 101    | 13511      | 99     | 14425      | 105    |
| 10008      | 96     | 11360      | 98     | 13252      | 121    | 13417      | 101    | 13512      | 99     | 14430      | 105    |
| 10025      | 96     | 11410      | 100    | 13253      | 121    | 13418      | 101    | 13513      | 99     | 14435      | 105    |
| 10033      | 96     | 11410      | 365    | 13254      | 121    | 13419      | 101    | 13514      | 99     | 14440      | 105    |
| 10035      | 96     | 11416      | 99     | 13255      | 121    | 13420      | 101    | 13515      | 99     | 14445      | 105    |
| 10043      | 96     | 11420      | 100    | 13256      | 121    | 13421      | 101    | 13516      | 99     | 14446      | 105    |
| 10045      | 96     | 11425      | 100    | 13257      | 121    | 13422      | 101    | 13517      | 99     | 14450      | 105    |
| 10048      | 96     | 11444      | 100    | 13258      | 121    | 13423      | 101    | 13518      | 99     | 14451      | 105    |
| 10110      | 96     | 11445      | 100    | 13259      | 121    | 13424      | 101    | 13519      | 99     | 14455      | 105    |
| 10120      | 96     | 12010      | 99     | 13260      | 120    | 13425      | 101    | 13520      | 99     | 14456      | 105    |
| 10130      | 96     | 12020      | 99     | 13261      | 117    | 13426      | 101    | 13521      | 99     | 14457      | 105    |
| 10330      | 96     | 12030      | 99     | 13262      | 117    | 13427      | 101    | 13522      | 99     | 14458      | 105    |
| 10332      | 96     | 12050      | 99     | 13263      | 117    | 13428      | 101    | 13523      | 99     | 14471      | 105    |
| 10334      | 96     | 12110      | 99     | 13264      | 116    | 13429      | 101    | 13524      | 99     | 14472      | 105    |
| 10336      | 96     | 12120      | 99     | 13265      | 116    | 13430      | 101    | 13525      | 99     | 14473      | 105    |
| 10430      | 97     | 12130      | 99     | 13266      | 116    | 13431      | 101    | 13526      | 99     | 14474      | 105    |
| 10450      | 97     | 12150      | 99     | 13267      | 117    | 13432      | 101    | 13527      | 99     | 14480      | 104    |
| 10490      | 97     | 12220      | 99     | 13268      | 116    | 13433      | 101    | 13528      | 99     | 14485      | 109    |
| 10996      | 97     | 12230      | 99     | 13269      | 116    | 13434      | 101    | 13529      | 99     | 14485      | 271    |
| 10998      | 97     | 12250      | 99     | 13270      | 116    | 13435      | 101    | 13530      | 99     | 14486      | 109    |
| 10999      | 97     | 12433      | 100    | 13271      | 116    | 13436      | 101    | 13531      | 99     | 14486      | 271    |
| 11002      | 99     | 12435      | 100    | 13272      | 116    | 13437      | 101    | 13532      | 99     | 14490      | 105    |
| 11003      | 99     | 13010      | 101    | 13273      | 116    | 13438      | 101    | 13533      | 99     | 14491      | 105    |
| 11005      | 99     | 13020      | 101    | 13274      | 116    | 13439      | 101    | 13534      | 99     | 14492      | 105    |
| 11006      | 99     | 13021      | 101    | 13275      | 116    | 13440      | 101    | 14001      | 102    | 14493      | 105    |
| 11007      | 99     | 13022      | 101    | 13276      | 117    | 13441      | 101    | 14002      | 102    | 14494      | 105    |
| 11008      | 99     | 13023      | 101    | 13277      | 120    | 13442      | 101    | 14003      | 102    | 15003      | 107    |
| 11082      | 99     | 13111      | 101    | 13278      | 116    | 13443      | 101    | 14004      | 102    | 15004      | 107    |
| 11083      | 99     | 13120      | 101    | 13279      | 117    | 13444      | 101    | 14006      | 102    | 15005      | 107    |
| 11085      | 99     | 13200      | 118    | 13280      | 117    | 13445      | 101    | 14007      | 102    | 15006      | 107    |
| 11102      | 98     | 13201      | 118    | 13281      | 102    | 13446      | 101    | 14008      | 102    | 15008      | 107    |
| 11103      | 98     | 13202      | 118    | 13282      | 102    | 13447      | 101    | 14009      | 102    | 15010      | 107    |
| 11105      | 98     | 13205      | 119    | 13284      | 117    | 13448      | 101    | 14010      | 103    | 15012      | 107    |
| 11106      | 98     | 13206      | 119    | 13285      | 102    | 13449      | 101    | 14011      | 103    | 15015      | 107    |
| 11107      | 98     | 13207      | 119    | 13288      | 117    | 13450      | 101    | 14012      | 103    | 15018      | 107    |
| 11110      | 98     | 13208      | 119    | 13290      | 217    | 13451      | 101    | 14013      | 102    | 15020      | 107    |
| 11200      | 99     | 13211      | 101    | 13293      | 217    | 13452      | 101    | 14015      | 103    | 15033      | 106    |
| 11201      | 99     | 13212      | 119    | 13294      | 217    | 13453      | 101    | 14017      | 103    | 15034      | 106    |
| 11202      | 99     | 13214      | 118    | 13295      | 120    | 13454      | 101    | 14019      | 103    | 15035      | 106    |
| 11204      | 99     | 13216      | 118    | 13296      | 120    | 13455      | 101    | 14025      | 105    | 15036      | 106    |
| 11205      | 99     | 13217      | 118    | 13350      | 121    | 13456      | 101    | 14030      | 103    | 15037      | 106    |
| 11206      | 99     | 13218      | 118    | 13351      | 121    | 13457      | 101    | 14035      | 102    | 15039      | 106    |
| 11207      | 99     | 13219      | 118    | 13352      | 121    | 13458      | 101    | 14040      | 102    | 15103      | 107    |
| 11208      | 99     | 13220      | 101    | 13353      | 121    | 13459      | 101    | 14045      | 102    | 15104      | 107    |
| 11209      | 99     | 13222      | 118    | 13354      | 121    | 13460      | 101    | 14060      | 103    | 15105      | 107    |
| 11210      | 99     | 13223      | 118    | 13355      | 121    | 13461      | 101    | 14070      | 103    | 15106      | 107    |
| 11220      | 98     | 13224      | 118    | 13360      | 121    | 13462      | 101    | 14075      | 103    | 15108      | 107    |
| 11221      | 98     | 13225      | 118    | 13361      | 121    | 13463      | 101    | 14077      | 103    | 15110      | 107    |
| 11226      | 98     | 13226      | 118    | 13362      | 121    | 13464      | 101    | 14080      | 102    | 15112      | 107    |
| 11239      | 98     | 13227      | 118    | 13363      | 121    | 13465      | 101    | 14090      | 104    | 15115      | 107    |
| 11259      | 98     | 13228      | 118    | 13364      | 121    | 13466      | 101    | 14091      | 104    | 15118      | 107    |
| 11260      | 98     | 13229      | 118    | 13365      | 121    | 13467      | 101    | 14220      | 105    | 15120      | 107    |
| 11311      | 100    | 13230      | 118    | 13399      | 101    | 13468      | 101    | 14225      | 105    | 15204      | 107    |
| 11312      | 100    | 13231      | 118    | 13400      | 101    | 13469      | 101    | 14230      | 105    | 15205      | 107    |
| 11313      | 100    | 13235      | 118    | 13401      | 101    | 13470      | 101    | 14235      | 105    | 15206      | 107    |
| 11314      | 100    | 13236      | 118    | 13402      | 101    | 13471      | 101    | 14240      | 105    | 15208      | 107    |
| 11323      | 98     | 13237      | 118    | 13403      | 101    | 13472      | 101    | 14250      | 105    | 15210      | 107    |
| 11325      | 98     | 13238      | 118    | 13404      | 101    | 13473      | 101    | 14350      | 105    | 15212      | 107    |
| 11327      | 98     | 13240      | 120    | 13405      | 101    | 13500      | 99     | 14360      | 105    | 15215      | 107    |
| 11333      | 98     | 13241      | 120    | 13406      | 101    | 13501      | 99     | 14370      | 105    | 15218      | 107    |
| 11335      | 98     | 13242      | 120    | 13407      | 101    | 13502      | 99     | 14380      | 105    | 15220      | 107    |
| 11337      | 98     | 13243      | 120    | 13408      | 101    | 13503      | 99     | 14399      | 105    | 15230      | 107    |
| 11338      | 98     | 13244      | 120    | 13409      | 101    | 13504      | 99     | 14410      | 105    | 15235      | 108    |
| 11343      | 98     | 13245      | 120    | 13410      | 101    | 13505      | 99     | 14411      | 105    | 15301      | 109    |
| 11345      | 98     | 13246      | 119    | 13411      | 101    | 13506      | 99     | 14415      | 104    | 15301      | 271    |
| 11347      | 98     | 13247      | 119    | 13412      | 101    | 13507      | 99     | 14417      | 104    | 15310      | 108    |
| 11353      | 98     | 13248      | 119    | 13413      | 101    | 13508      | 99     | 14418      | 104    | 15310      | 270    |



# LISTA PRODUSELOR



| Cod produs | pagina | Cod produs | pagina | Cod produs | pagina | Cod produs | pagina | Cod produs | pagina | Cod produs | pagina |
|------------|--------|------------|--------|------------|--------|------------|--------|------------|--------|------------|--------|
| 15315      | 108    | 15810      | 109    | 16003      | 122    | 16075      | 130    | 16300      | 139    | 17037      | 137    |
| 15315      | 270    | 15810      | 271    | 16004      | 122    | 16077      | 130    | 16301      | 139    | 17038      | 177    |
| 15318      | 108    | 15812      | 109    | 16005      | 122    | 16078      | 130    | 16303      | 139    | 17039      | 176    |
| 15318      | 270    | 15812      | 271    | 16006      | 122    | 16081      | 130    | 16304      | 139    | 17040      | 174    |
| 15320      | 108    | 15815      | 109    | 16010      | 122    | 16082      | 129    | 16305      | 138    | 17041      | 174    |
| 15320      | 270    | 15815      | 271    | 16010      | 122    | 16083      | 131    | 16306      | 138    | 17042      | 174    |
| 15325      | 108    | 15818      | 109    | 16011      | 122    | 16084      | 131    | 16307      | 138    | 17043      | 174    |
| 15325      | 270    | 15818      | 271    | 16011      | 122    | 16085      | 126    | 16308      | 138    | 17044      | 174    |
| 15330      | 108    | 15820      | 109    | 16011      | 122    | 16086      | 126    | 16309      | 138    | 17045      | 174    |
| 15330      | 270    | 15820      | 271    | 16012      | 122    | 16087      | 127    | 16310      | 139    | 17046      | 177    |
| 15335      | 108    | 15825      | 109    | 16012      | 122    | 16090      | 125    | 16310      | 139    | 17047      | 172    |
| 15335      | 270    | 15825      | 271    | 16012      | 122    | 16091      | 125    | 16311      | 139    | 17048      | 177    |
| 15340      | 108    | 15830      | 109    | 16013      | 122    | 16095      | 127    | 16311      | 139    | 17049      | 177    |
| 15340      | 270    | 15830      | 271    | 16013      | 122    | 16099      | 124    | 16311      | 139    | 17050      | 139    |
| 15415      | 108    | 15850      | 109    | 16016      | 122    | 16100      | 124    | 16312      | 139    | 17050      | 181    |
| 15415      | 270    | 15850      | 271    | 16017      | 122    | 16105      | 124    | 16312      | 139    | 17051      | 177    |
| 15418      | 108    | 15853      | 109    | 16019      | 122    | 16110      | 124    | 16315      | 137    | 17052      | 177    |
| 15418      | 270    | 15853      | 271    | 16021      | 128    | 16115      | 124    | 16315      | 137    | 17053      | 177    |
| 15420      | 108    | 15855      | 109    | 16023      | 127    | 16120      | 124    | 16319      | 139    | 17054      | 177    |
| 15420      | 270    | 15855      | 271    | 16024      | 128    | 16125      | 124    | 16320      | 139    | 17055      | 177    |
| 15425      | 108    | 15860      | 109    | 16025      | 125    | 16130      | 126    | 16321      | 139    | 17056      | 177    |
| 15425      | 270    | 15860      | 271    | 16026      | 128    | 16131      | 124    | 16321      | 229    | 17057      | 177    |
| 15430      | 108    | 15870      | 109    | 16028      | 128    | 16135      | 126    | 16401      | 181    | 17058      | 177    |
| 15430      | 270    | 15870      | 271    | 16029      | 125    | 16136      | 125    | 16405      | 181    | 17059      | 176    |
| 15510      | 108    | 15880      | 109    | 16030      | 128    | 16137      | 125    | 16406      | 181    | 17060      | 176    |
| 15510      | 270    | 15880      | 271    | 16031      | 128    | 16140      | 126    | 16407      | 181    | 17061      | 176    |
| 15515      | 108    | 15885      | 256    | 16032      | 128    | 16141      | 128    | 16408      | 181    | 17062      | 176    |
| 15515      | 270    | 15886      | 256    | 16033      | 127    | 16142      | 125    | 16420      | 181    | 17063      | 175    |
| 15518      | 108    | 15886      | 349    | 16034      | 126    | 16143      | 125    | 16500      | 176    | 17064      | 175    |
| 15518      | 270    | 15887      | 256    | 16035      | 127    | 16144      | 125    | 16501      | 176    | 17065      | 175    |
| 15520      | 108    | 15887      | 349    | 16036      | 129    | 16145      | 125    | 16502      | 176    | 17066      | 175    |
| 15520      | 270    | 15888      | 256    | 16037      | 127    | 16146      | 125    | 16990      | 136    | 17067      | 175    |
| 15525      | 108    | 15888      | 349    | 16039      | 127    | 16147      | 126    | 16990      | 320    | 17068      | 175    |
| 15525      | 270    | 15889      | 256    | 16041      | 129    | 16150      | 125    | 16991      | 136    | 17069      | 175    |
| 15530      | 108    | 15893      | 109    | 16042      | 129    | 16151      | 125    | 16991      | 320    | 17070      | 175    |
| 15530      | 270    | 15893      | 271    | 16042      | 279    | 16198      | 131    | 16998      | 122    | 17071      | 175    |
| 15535      | 108    | 15894      | 109    | 16043      | 128    | 16199      | 131    | 16999      | 122    | 17072      | 175    |
| 15535      | 270    | 15894      | 271    | 16044      | 126    | 16201      | 132    | 17001      | 171    | 17075      | 175    |
| 15540      | 108    | 15895      | 109    | 16046      | 128    | 16202      | 173    | 17002      | 171    | 17076      | 175    |
| 15540      | 270    | 15895      | 271    | 16049      | 129    | 16205      | 173    | 17003      | 171    | 17077      | 175    |
| 15615      | 108    | 15904      | 111    | 16050      | 129    | 16206      | 173    | 17004      | 171    | 17078      | 177    |
| 15615      | 270    | 15906      | 111    | 16051      | 129    | 16208      | 173    | 17005      | 171    | 17079      | 176    |
| 15620      | 108    | 15908      | 111    | 16052      | 129    | 16209      | 133    | 17006      | 171    | 17080      | 176    |
| 15620      | 270    | 15910      | 111    | 16053      | 128    | 16209      | 365    | 17007      | 171    | 17081      | 176    |
| 15625      | 108    | 15912      | 111    | 16054      | 129    | 16210      | 132    | 17008      | 171    | 17082      | 176    |
| 15625      | 270    | 15915      | 111    | 16055      | 128    | 16211      | 132    | 17009      | 171    | 17083      | 178    |
| 15630      | 108    | 15920      | 111    | 16056      | 278    | 16212      | 132    | 17010      | 171    | 17084      | 176    |
| 15630      | 270    | 15954      | 111    | 16057      | 126    | 16218      | 133    | 17011      | 171    | 17085      | 176    |
| 15710      | 109    | 15956      | 111    | 16058      | 126    | 16219      | 133    | 17012      | 176    | 17086      | 176    |
| 15710      | 270    | 15958      | 111    | 16059      | 129    | 16220      | 133    | 17013      | 176    | 17087      | 172    |
| 15715      | 109    | 15960      | 111    | 16060      | 130    | 16221      | 133    | 17014      | 176    | 17089      | 178    |
| 15715      | 270    | 15962      | 111    | 16061      | 130    | 16222      | 133    | 17015      | 178    | 17090      | 178    |
| 15720      | 109    | 15965      | 111    | 16062      | 130    | 16223      | 133    | 17016      | 178    | 17091      | 178    |
| 15720      | 270    | 15970      | 111    | 16063      | 130    | 16224      | 134    | 17017      | 178    | 17092      | 178    |
| 15725      | 109    | 15980      | 111    | 16064      | 130    | 16225      | 132    | 17019      | 178    | 17093      | 178    |
| 15725      | 270    | 15981      | 111    | 16065      | 130    | 16226      | 134    | 17020      | 177    | 17094      | 171    |
| 15730      | 109    | 15983      | 100    | 16066      | 124    | 16227      | 134    | 17021      | 177    | 17095      | 171    |
| 15730      | 270    | 15985      | 100    | 16066      | 130    | 16228      | 134    | 17022      | 177    | 17096      | 171    |
| 15735      | 109    | 15988      | 100    | 16067      | 130    | 16229      | 132    | 17023      | 175    | 17097      | 171    |
| 15735      | 270    | 15989      | 100    | 16068      | 130    | 16230      | 132    | 17024      | 171    | 17098      | 171    |
| 15740      | 109    | 15990      | 111    | 16069      | 129    | 16231      | 132    | 17025      | 174    | 17099      | 171    |
| 15740      | 270    | 15991      | 111    | 16070      | 129    | 16231      | 135    | 17026      | 137    | 17100      | 171    |
| 15754      | 110    | 15992      | 111    | 16070      | 131    | 16232      | 134    | 17027      | 137    | 17101      | 169    |
| 15756      | 110    | 15993      | 111    | 16071      | 127    | 16232      | 174    | 17028      | 177    | 17102      | 169    |
| 15758      | 110    | 15996      | 110    | 16071      | 130    | 16234      | 132    | 17029      | 176    | 17103      | 169    |
| 15760      | 110    | 15997      | 110    | 16072      | 130    | 16235      | 133    | 17033      | 176    | 17104      | 169    |
| 15762      | 110    | 15998      | 110    | 16073      | 131    | 16236      | 133    | 17034      | 175    | 17105      | 169    |
| 15768      | 110    | 15999      | 110    | 16074      | 126    | 16281      | 127    | 17035      | 175    | 17108      | 171    |
| 15770      | 110    | 16002      | 122    | 16074      | 131    | 16282      | 127    | 17036      | 175    | 17109      | 175    |

| Cod produs | pagina | Cod produs | pagina | Cod produs | pagina | Cod produs | pagina | Cod produs | pagina | Cod produs | pagina |
|------------|--------|------------|--------|------------|--------|------------|--------|------------|--------|------------|--------|
| 17110      | 171    | 17238      | 156    | 17393      | 160    | 17528      | 165    | 17622      | 164    | 17831      | 159    |
| 17111      | 179    | 17240      | 158    | 17394      | 160    | 17532      | 166    | 17623      | 164    | 17832      | 159    |
| 17112      | 179    | 17241      | 158    | 17395      | 160    | 17533      | 166    | 17624      | 164    | 17835      | 159    |
| 17113      | 179    | 17242      | 158    | 17396      | 160    | 17534      | 166    | 17625      | 164    | 17836      | 159    |
| 17116      | 179    | 17243      | 158    | 17397      | 160    | 17539      | 165    | 17626      | 164    | 17837      | 159    |
| 17117      | 179    | 17244      | 158    | 17398      | 160    | 17548      | 164    | 17628      | 164    | 17838      | 159    |
| 17121      | 179    | 17245      | 155    | 17400      | 161    | 17549      | 164    | 17629      | 164    | 17839      | 159    |
| 17122      | 179    | 17247      | 153    | 17401      | 160    | 17550      | 164    | 17630      | 164    | 17840      | 159    |
| 17125      | 172    | 17250      | 161    | 17402      | 160    | 17551      | 164    | 17631      | 164    | 17841      | 159    |
| 17126      | 172    | 17255      | 161    | 17405      | 160    | 17552      | 164    | 17632      | 164    | 17842      | 159    |
| 17127      | 172    | 17259      | 153    | 17406      | 160    | 17553      | 164    | 17633      | 164    | 17843      | 159    |
| 17128      | 172    | 17260      | 153    | 17407      | 160    | 17554      | 164    | 17640      | 166    | 17844      | 159    |
| 17130      | 172    | 17261      | 167    | 17410      | 160    | 17555      | 164    | 17642      | 166    | 17845      | 159    |
| 17133      | 172    | 17262      | 167    | 17411      | 160    | 17556      | 164    | 17643      | 166    | 17846      | 159    |
| 17135      | 172    | 17292      | 158    | 17412      | 160    | 17557      | 164    | 17644      | 166    | 17847      | 159    |
| 17137      | 172    | 17294      | 158    | 17413      | 160    | 17558      | 164    | 17645      | 166    | 17848      | 159    |
| 17138      | 172    | 17295      | 158    | 17414      | 160    | 17559      | 164    | 17650      | 166    | 17849      | 159    |
| 17140      | 169    | 17296      | 158    | 17415      | 160    | 17560      | 164    | 17651      | 166    | 17850      | 159    |
| 17142      | 169    | 17297      | 158    | 17416      | 160    | 17561      | 164    | 17652      | 166    | 17851      | 159    |
| 17145      | 169    | 17298      | 158    | 17420      | 160    | 17562      | 164    | 17653      | 166    | 17852      | 159    |
| 17146      | 169    | 17299      | 158    | 17421      | 160    | 17563      | 164    | 17654      | 166    | 17853      | 159    |
| 17148      | 169    | 17300      | 178    | 17422      | 160    | 17564      | 164    | 17655      | 166    | 17854      | 159    |
| 17150      | 175    | 17301      | 178    | 17427      | 161    | 17565      | 164    | 17656      | 166    | 17855      | 159    |
| 17151      | 175    | 17302      | 178    | 17450      | 167    | 17566      | 164    | 17657      | 166    | 17856      | 159    |
| 17158      | 181    | 17303      | 178    | 17451      | 167    | 17567      | 164    | 17658      | 166    | 17860      | 159    |
| 17159      | 181    | 17304      | 178    | 17452      | 167    | 17568      | 164    | 17659      | 166    | 17861      | 159    |
| 17160      | 181    | 17305      | 178    | 17454      | 168    | 17569      | 164    | 17660      | 164    | 17862      | 159    |
| 17165      | 179    | 17306      | 178    | 17455      | 161    | 17570      | 164    | 17661      | 164    | 17863      | 159    |
| 17167      | 179    | 17308      | 159    | 17455      | 168    | 17571      | 164    | 17662      | 164    | 17864      | 159    |
| 17169      | 179    | 17309      | 159    | 17456      | 168    | 17572      | 164    | 17663      | 164    | 17865      | 159    |
| 17170      | 179    | 17310      | 159    | 17458      | 168    | 17573      | 164    | 17664      | 164    | 17866      | 159    |
| 17172      | 178    | 17311      | 159    | 17459      | 168    | 17574      | 164    | 17665      | 164    | 17867      | 159    |
| 17175      | 180    | 17312      | 159    | 17460      | 164    | 17575      | 164    | 17666      | 164    | 17868      | 159    |
| 17177      | 180    | 17313      | 159    | 17461      | 164    | 17576      | 164    | 17667      | 164    | 17869      | 159    |
| 17178      | 172    | 17314      | 159    | 17462      | 164    | 17577      | 164    | 17668      | 164    | 17870      | 159    |
| 17180      | 172    | 17315      | 159    | 17463      | 164    | 17578      | 164    | 17669      | 164    | 17871      | 159    |
| 17181      | 172    | 17316      | 159    | 17464      | 164    | 17579      | 164    | 17670      | 164    | 17872      | 159    |
| 17182      | 45     | 17317      | 159    | 17465      | 164    | 17580      | 164    | 17671      | 164    | 17873      | 159    |
| 17182      | 137    | 17318      | 159    | 17467      | 164    | 17581      | 164    | 17672      | 164    | 17874      | 159    |
| 17183      | 45     | 17319      | 159    | 17468      | 164    | 17582      | 164    | 17674      | 164    | 17875      | 159    |
| 17183      | 137    | 17320      | 159    | 17469      | 164    | 17583      | 164    | 17675      | 164    | 17876      | 159    |
| 17185      | 181    | 17321      | 159    | 17470      | 164    | 17584      | 164    | 17676      | 164    | 17877      | 159    |
| 17186      | 180    | 17322      | 159    | 17471      | 164    | 17585      | 164    | 17677      | 164    | 17878      | 159    |
| 17187      | 181    | 17324      | 159    | 17472      | 164    | 17586      | 164    | 17678      | 164    | 17879      | 159    |
| 17188      | 181    | 17327      | 159    | 17473      | 164    | 17587      | 164    | 17679      | 164    | 17880      | 159    |
| 17189      | 181    | 17330      | 159    | 17475      | 166    | 17589      | 164    | 17680      | 168    | 17881      | 159    |
| 17190      | 174    | 17332      | 159    | 17476      | 166    | 17590      | 164    | 17681      | 168    | 17882      | 159    |
| 17191      | 174    | 17333      | 159    | 17480      | 164    | 17591      | 164    | 17682      | 168    | 17883      | 159    |
| 17192      | 174    | 17334      | 159    | 17481      | 164    | 17592      | 164    | 17683      | 164    | 17884      | 159    |
| 17193      | 174    | 17338      | 167    | 17482      | 164    | 17593      | 164    | 17685      | 165    | 17885      | 159    |
| 17197      | 165    | 17341      | 178    | 17483      | 164    | 17600      | 167    | 17761      | 164    | 17886      | 159    |
| 17198      | 165    | 17342      | 178    | 17484      | 164    | 17601      | 167    | 17769      | 164    | 17887      | 159    |
| 17199      | 165    | 17350      | 162    | 17485      | 164    | 17603      | 167    | 17788      | 164    | 17888      | 159    |
| 17200      | 165    | 17351      | 162    | 17486      | 164    | 17605      | 164    | 17795      | 164    | 17889      | 159    |
| 17201      | 165    | 17352      | 162    | 17487      | 164    | 17606      | 164    | 17806      | 164    | 17890      | 159    |
| 17202      | 165    | 17353      | 162    | 17488      | 164    | 17607      | 164    | 17810      | 161    | 17891      | 159    |
| 17203      | 167    | 17357      | 162    | 17489      | 164    | 17608      | 164    | 17811      | 161    | 17892      | 159    |
| 17204      | 167    | 17359      | 162    | 17490      | 164    | 17609      | 164    | 17812      | 161    | 17895      | 159    |
| 17205      | 167    | 17361      | 162    | 17491      | 164    | 17610      | 164    | 17820      | 159    | 17896      | 159    |
| 17206      | 167    | 17380      | 161    | 17492      | 164    | 17611      | 164    | 17821      | 159    | 17897      | 159    |
| 17229      | 155    | 17381      | 161    | 17493      | 164    | 17612      | 164    | 17822      | 159    | 17898      | 159    |
| 17230      | 155    | 17382      | 160    | 17494      | 164    | 17613      | 164    | 17823      | 159    | 17904      | 159    |
| 17231      | 155    | 17383      | 160    | 17495      | 164    | 17614      | 164    | 17824      | 159    | 17905      | 159    |
| 17233      | 155    | 17384      | 160    | 17496      | 164    | 17615      | 164    | 17825      | 159    | 17907      | 159    |
| 17234      | 155    | 17385      | 160    | 17501      | 166    | 17616      | 164    | 17826      | 159    | 17910      | 159    |
| 17235      | 156    | 17386      | 160    | 17506      | 165    | 17617      | 164    | 17827      | 159    | 17914      | 159    |
| 17236      | 156    | 17390      | 160    | 17508      | 165    | 17619      | 165    | 17828      | 159    | 17916      | 159    |
| 17237      | 154    | 17391      | 160    | 17512      | 166    | 17620      | 166    | 17829      | 159    | 17922      | 159    |
| 17238      | 153    | 17392      | 160    | 17526      | 165    | 17621      | 166    | 17830      | 159    | 17924      | 159    |

# LISTA PRODUSELOR



| Cod produs | pagina | Cod produs | pagina | Cod produs | pagina | Cod produs | pagina | Cod produs | pagina | Cod produs | pagina |
|------------|--------|------------|--------|------------|--------|------------|--------|------------|--------|------------|--------|
| 17926      | 159    | 18302      | 143    | 18498      | 163    | 18638      | 147    | 18828      | 148    | 18971      | 160    |
| 17930      | 159    | 18303      | 143    | 18499      | 163    | 18639      | 147    | 18829      | 148    | 18993      | 150    |
| 17934      | 159    | 18304      | 143    | 18500      | 163    | 18640      | 147    | 18830      | 148    | 18994      | 150    |
| 17935      | 159    | 18310      | 140    | 18501      | 162    | 18641      | 147    | 18831      | 148    | 19001      | 197    |
| 17943      | 159    | 18311      | 140    | 18508      | 163    | 18645      | 147    | 18832      | 148    | 19002      | 197    |
| 17944      | 159    | 18312      | 140    | 18510      | 162    | 18646      | 147    | 18835      | 148    | 19003      | 197    |
| 17970      | 148    | 18313      | 140    | 18511      | 162    | 18680      | 147    | 18836      | 148    | 19004      | 197    |
| 17971      | 148    | 18321      | 140    | 18512      | 162    | 18685      | 147    | 18837      | 148    | 19005      | 197    |
| 17972      | 148    | 18322      | 140    | 18513      | 162    | 18710      | 146    | 18838      | 148    | 19006      | 197    |
| 17973      | 148    | 18340      | 141    | 18514      | 162    | 18711      | 146    | 18839      | 148    | 19008      | 197    |
| 17974      | 148    | 18350      | 140    | 18515      | 162    | 18712      | 146    | 18840      | 148    | 19010      | 197    |
| 17975      | 148    | 18351      | 140    | 18516      | 162    | 18715      | 146    | 18841      | 148    | 19015      | 197    |
| 17976      | 148    | 18352      | 140    | 18518      | 162    | 18716      | 146    | 18842      | 148    | 19020      | 197    |
| 17980      | 148    | 18353      | 140    | 18519      | 162    | 18717      | 146    | 18843      | 148    | 19021      | 195    |
| 17981      | 148    | 18354      | 140    | 18520      | 162    | 18720      | 146    | 18844      | 148    | 19022      | 195    |
| 17982      | 148    | 18355      | 140    | 18521      | 162    | 18721      | 146    | 18845      | 148    | 19023      | 195    |
| 17983      | 148    | 18356      | 140    | 18522      | 162    | 18722      | 146    | 18846      | 148    | 19024      | 195    |
| 18062      | 142    | 18357      | 140    | 18523      | 162    | 18723      | 146    | 18847      | 148    | 19025      | 195    |
| 18063      | 142    | 18358      | 140    | 18524      | 162    | 18724      | 146    | 18850      | 148    | 19026      | 195    |
| 18064      | 142    | 18359      | 140    | 18527      | 162    | 18725      | 146    | 18851      | 148    | 19028      | 195    |
| 18065      | 142    | 18360      | 140    | 18567      | 162    | 18750      | 147    | 18852      | 148    | 19030      | 195    |
| 18066      | 142    | 18400      | 143    | 18572      | 162    | 18751      | 147    | 18853      | 148    | 19031      | 195    |
| 18067      | 142    | 18401      | 143    | 18575      | 162    | 18753      | 147    | 18855      | 148    | 19032      | 195    |
| 18070      | 142    | 18402      | 141    | 18576      | 162    | 18755      | 147    | 18856      | 148    | 19034      | 195    |
| 18071      | 142    | 18403      | 141    | 18577      | 162    | 18760      | 147    | 18860      | 148    | 19036      | 195    |
| 18072      | 142    | 18404      | 141    | 18578      | 162    | 18761      | 147    | 18861      | 148    | 19041      | 195    |
| 18075      | 142    | 18408      | 145    | 18579      | 162    | 18762      | 147    | 18862      | 148    | 19042      | 195    |
| 18076      | 142    | 18409      | 145    | 18580      | 162    | 18763      | 147    | 18863      | 148    | 19043      | 195    |
| 18077      | 142    | 18410      | 142    | 18581      | 162    | 18764      | 147    | 18864      | 148    | 19044      | 195    |
| 18080      | 142    | 18411      | 142    | 18582      | 162    | 18765      | 147    | 18865      | 148    | 19045      | 195    |
| 18081      | 142    | 18413      | 142    | 18583      | 162    | 18766      | 147    | 18866      | 148    | 19046      | 195    |
| 18082      | 142    | 18415      | 144    | 18584      | 162    | 18767      | 147    | 18867      | 148    | 19050      | 197    |
| 18083      | 142    | 18416      | 144    | 18585      | 162    | 18768      | 147    | 18868      | 148    | 19051      | 197    |
| 18084      | 142    | 18417      | 144    | 18587      | 162    | 18769      | 147    | 18869      | 148    | 19052      | 197    |
| 18085      | 142    | 18418      | 143    | 18588      | 162    | 18770      | 147    | 18870      | 148    | 19053      | 197    |
| 18086      | 142    | 18419      | 144    | 18589      | 162    | 18771      | 147    | 18871      | 148    | 19054      | 197    |
| 18087      | 142    | 18420      | 144    | 18593      | 162    | 18772      | 147    | 18872      | 148    | 19055      | 197    |
| 18088      | 142    | 18421      | 152    | 18600      | 149    | 18775      | 147    | 18873      | 148    | 19056      | 197    |
| 18089      | 142    | 18422      | 141    | 18601      | 149    | 18776      | 147    | 18874      | 148    | 19057      | 197    |
| 18090      | 142    | 18423      | 142    | 18602      | 149    | 18777      | 147    | 18900      | 151    | 19058      | 195    |
| 18091      | 142    | 18424      | 141    | 18603      | 158    | 18795      | 149    | 18901      | 151    | 19059      | 195    |
| 18092      | 142    | 18425      | 140    | 18604      | 161    | 18796      | 149    | 18905      | 151    | 19060      | 196    |
| 18101      | 143    | 18426      | 145    | 18605      | 149    | 18797      | 149    | 18906      | 151    | 19061      | 196    |
| 18102      | 143    | 18427      | 145    | 18607      | 149    | 18798      | 149    | 18907      | 152    | 19062      | 196    |
| 18103      | 143    | 18428      | 115    | 18608      | 144    | 18799      | 149    | 18908      | 151    | 19063      | 196    |
| 18104      | 143    | 18429      | 115    | 18609      | 150    | 18800      | 148    | 18909      | 151    | 19064      | 196    |
| 18105      | 143    | 18430      | 152    | 18610      | 150    | 18801      | 148    | 18910      | 145    | 19065      | 196    |
| 18106      | 143    | 18431      | 144    | 18611      | 150    | 18802      | 148    | 18915      | 152    | 19066      | 195    |
| 18107      | 143    | 18432      | 146    | 18612      | 150    | 18803      | 148    | 18920      | 160    | 19067      | 195    |
| 18108      | 143    | 18433      | 144    | 18613      | 150    | 18804      | 148    | 18921      | 160    | 19068      | 195    |
| 18110      | 143    | 18434      | 140    | 18614      | 150    | 18805      | 148    | 18922      | 160    | 19069      | 195    |
| 18113      | 140    | 18435      | 145    | 18615      | 150    | 18806      | 148    | 18925      | 160    | 19070      | 195    |
| 18114      | 140    | 18437      | 145    | 18618      | 150    | 18807      | 148    | 18926      | 160    | 19071      | 195    |
| 18115      | 140    | 18440      | 152    | 18619      | 149    | 18810      | 148    | 18927      | 160    | 19074      | 195    |
| 18116      | 140    | 18445      | 173    | 18619      | 161    | 18811      | 148    | 18928      | 160    | 19075      | 195    |
| 18118      | 140    | 18450      | 143    | 18620      | 147    | 18812      | 148    | 18929      | 160    | 19076      | 195    |
| 18120      | 140    | 18451      | 143    | 18621      | 147    | 18813      | 148    | 18930      | 160    | 19077      | 195    |
| 18124      | 140    | 18455      | 143    | 18623      | 147    | 18814      | 148    | 18931      | 160    | 19081      | 195    |
| 18125      | 140    | 18456      | 143    | 18625      | 147    | 18815      | 148    | 18934      | 160    | 19082      | 195    |
| 18201      | 143    | 18460      | 143    | 18627      | 147    | 18816      | 148    | 18939      | 160    | 19083      | 195    |
| 18202      | 143    | 18476      | 162    | 18628      | 147    | 18817      | 148    | 18948      | 160    | 19084      | 195    |
| 18203      | 143    | 18490      | 163    | 18630      | 147    | 18820      | 148    | 18950      | 160    | 19085      | 195    |
| 18204      | 143    | 18491      | 163    | 18631      | 147    | 18821      | 148    | 18951      | 160    | 19086      | 195    |
| 18210      | 140    | 18492      | 163    | 18632      | 147    | 18822      | 148    | 18954      | 160    | 19088      | 195    |
| 18211      | 140    | 18493      | 163    | 18633      | 147    | 18823      | 148    | 18955      | 160    | 19090      | 195    |
| 18212      | 140    | 18494      | 162    | 18634      | 147    | 18824      | 148    | 18956      | 160    | 19092      | 195    |
| 18215      | 140    | 18495      | 162    | 18635      | 147    | 18825      | 148    | 18960      | 160    | 19095      | 195    |
| 18216      | 140    | 18496      | 163    | 18636      | 147    | 18826      | 148    | 18961      | 160    | 19096      | 195    |
| 18301      | 143    | 18497      | 163    | 18637      | 147    | 18827      | 148    | 18963      | 160    | 19097      | 195    |

| Cod produs | pagina | Cod produs | pagina | Cod produs | pagina | Cod produs | pagina | Cod produs | pagina | Cod produs | pagina |
|------------|--------|------------|--------|------------|--------|------------|--------|------------|--------|------------|--------|
| 19098      | 195    | 19394      | 317    | 19473      | 202    | 19580      | 56     | 19643      | 56     | 19704      | 57     |
| 19100      | 196    | 19395      | 317    | 19474      | 202    | 19585      | 56     | 19644      | 56     | 19705      | 57     |
| 19106      | 195    | 19396      | 317    | 19477      | 202    | 19585      | 56     | 19645      | 56     | 19705      | 57     |
| 19108      | 195    | 19397      | 317    | 19478      | 202    | 19586      | 56     | 19645      | 56     | 19706      | 57     |
| 19109      | 195    | 19398      | 197    | 19480      | 202    | 19587      | 56     | 19646      | 56     | 19707      | 57     |
| 19110      | 200    | 19399      | 197    | 19481      | 202    | 19588      | 56     | 19647      | 56     | 19708      | 57     |
| 19115      | 44     | 19400      | 201    | 19483      | 202    | 19589      | 56     | 19648      | 56     | 19708      | 57     |
| 19115      | 197    | 19400      | 251    | 19485      | 201    | 19590      | 56     | 19649      | 56     | 19709      | 57     |
| 19124      | 196    | 19401      | 201    | 19486      | 201    | 19590      | 56     | 19650      | 56     | 19710      | 57     |
| 19136      | 196    | 19401      | 251    | 19487      | 201    | 19591      | 56     | 19650      | 56     | 19711      | 57     |
| 19148      | 196    | 19402      | 201    | 19490      | 135    | 19593      | 56     | 19651      | 56     | 19711      | 57     |
| 19149      | 196    | 19402      | 251    | 19491      | 135    | 19594      | 56     | 19652      | 56     | 19712      | 57     |
| 19150      | 196    | 19403      | 201    | 19492      | 135    | 19595      | 56     | 19653      | 56     | 19713      | 57     |
| 19151      | 196    | 19403      | 251    | 19493      | 135    | 19595      | 56     | 19654      | 56     | 19713      | 57     |
| 19202      | 198    | 19404      | 201    | 19494      | 135    | 19596      | 56     | 19655      | 56     | 19714      | 57     |
| 19208      | 199    | 19404      | 251    | 19495      | 135    | 19597      | 56     | 19656      | 56     | 19715      | 57     |
| 19209      | 199    | 19405      | 201    | 19496      | 135    | 19598      | 56     | 19657      | 56     | 19716      | 57     |
| 19211      | 199    | 19405      | 251    | 19497      | 135    | 19599      | 56     | 19658      | 56     | 19717      | 57     |
| 19245      | 198    | 19406      | 201    | 19498      | 135    | 19600      | 56     | 19659      | 56     | 19718      | 57     |
| 19246      | 198    | 19406      | 251    | 19499      | 135    | 19600      | 56     | 19660      | 56     | 19718      | 57     |
| 19247      | 198    | 19407      | 201    | 19501      | 135    | 19601      | 56     | 19661      | 56     | 19719      | 57     |
| 19248      | 198    | 19407      | 251    | 19502      | 135    | 19603      | 56     | 19662      | 56     | 19720      | 57     |
| 19249      | 198    | 19408      | 201    | 19510      | 134    | 19604      | 56     | 19663      | 56     | 19721      | 57     |
| 19251      | 199    | 19408      | 251    | 19515      | 134    | 19605      | 56     | 19664      | 56     | 19722      | 57     |
| 19252      | 199    | 19409      | 201    | 19520      | 134    | 19605      | 56     | 19665      | 56     | 19723      | 57     |
| 19253      | 199    | 19409      | 251    | 19530      | 56     | 19606      | 56     | 19669      | 56     | 19723      | 57     |
| 19254      | 199    | 19410      | 201    | 19530      | 56     | 19607      | 56     | 19670      | 57     | 19724      | 57     |
| 19255      | 199    | 19411      | 201    | 19535      | 56     | 19608      | 56     | 19671      | 57     | 19725      | 57     |
| 19265      | 199    | 19412      | 201    | 19535      | 56     | 19609      | 56     | 19672      | 57     | 19726      | 57     |
| 19270      | 199    | 19415      | 200    | 19536      | 56     | 19610      | 56     | 19673      | 57     | 19727      | 57     |
| 19271      | 199    | 19416      | 200    | 19537      | 56     | 19610      | 56     | 19673      | 57     | 19728      | 57     |
| 19272      | 199    | 19418      | 201    | 19538      | 56     | 19611      | 56     | 19674      | 57     | 19728      | 57     |
| 19281      | 199    | 19419      | 201    | 19539      | 56     | 19612      | 56     | 19675      | 57     | 19729      | 57     |
| 19290      | 199    | 19420      | 200    | 19540      | 56     | 19613      | 56     | 19676      | 57     | 19730      | 57     |
| 19293      | 199    | 19421      | 200    | 19540      | 56     | 19614      | 56     | 19677      | 57     | 19731      | 57     |
| 19294      | 199    | 19422      | 200    | 19543      | 56     | 19615      | 56     | 19678      | 57     | 19732      | 57     |
| 19295      | 199    | 19423      | 200    | 19544      | 56     | 19615      | 56     | 19678      | 57     | 19733      | 57     |
| 19297      | 199    | 19424      | 200    | 19545      | 56     | 19616      | 56     | 19679      | 57     | 19733      | 57     |
| 19301      | 316    | 19425      | 200    | 19545      | 56     | 19617      | 56     | 19680      | 57     | 19734      | 57     |
| 19303      | 196    | 19426      | 200    | 19550      | 56     | 19618      | 56     | 19681      | 57     | 19735      | 57     |
| 19306      | 317    | 19427      | 200    | 19550      | 56     | 19619      | 56     | 19682      | 57     | 19736      | 57     |
| 19308      | 317    | 19429      | 201    | 19552      | 56     | 19620      | 56     | 19683      | 57     | 19737      | 57     |
| 19310      | 317    | 19430      | 197    | 19552      | 56     | 19620      | 56     | 19683      | 57     | 19738      | 57     |
| 19312      | 317    | 19431      | 197    | 19554      | 56     | 19621      | 56     | 19684      | 57     | 19738      | 57     |
| 19314      | 317    | 19432      | 197    | 19555      | 56     | 19622      | 56     | 19685      | 57     | 19739      | 57     |
| 19326      | 316    | 19433      | 197    | 19555      | 56     | 19623      | 56     | 19686      | 57     | 19740      | 57     |
| 19328      | 316    | 19434      | 197    | 19557      | 56     | 19624      | 56     | 19687      | 57     | 19741      | 57     |
| 19330      | 316    | 19435      | 197    | 19558      | 56     | 19625      | 56     | 19688      | 57     | 19742      | 57     |
| 19332      | 316    | 19436      | 201    | 19559      | 56     | 19625      | 56     | 19688      | 57     | 19743      | 57     |
| 19333      | 316    | 19440      | 197    | 19560      | 56     | 19626      | 56     | 19689      | 57     | 19743      | 57     |
| 19335      | 316    | 19441      | 197    | 19560      | 56     | 19627      | 56     | 19690      | 57     | 19744      | 57     |
| 19337      | 316    | 19442      | 197    | 19562      | 56     | 19628      | 56     | 19691      | 57     | 19745      | 57     |
| 19340      | 316    | 19443      | 197    | 19562      | 56     | 19629      | 56     | 19692      | 57     | 19746      | 57     |
| 19370      | 317    | 19450      | 135    | 19564      | 56     | 19630      | 56     | 19693      | 57     | 19747      | 57     |
| 19371      | 317    | 19451      | 135    | 19565      | 56     | 19630      | 56     | 19693      | 57     | 19748      | 57     |
| 19374      | 317    | 19455      | 135    | 19565      | 56     | 19631      | 56     | 19694      | 57     | 19748      | 57     |
| 19380      | 316    | 19457      | 135    | 19567      | 56     | 19632      | 56     | 19695      | 57     | 19749      | 57     |
| 19381      | 316    | 19458      | 135    | 19568      | 56     | 19633      | 56     | 19695      | 57     | 19750      | 57     |
| 19382      | 316    | 19459      | 135    | 19568      | 56     | 19634      | 56     | 19696      | 57     | 19751      | 57     |
| 19383      | 316    | 19460      | 201    | 19570      | 56     | 19635      | 56     | 19697      | 57     | 19752      | 57     |
| 19384      | 316    | 19460      | 251    | 19570      | 56     | 19635      | 56     | 19698      | 57     | 19753      | 57     |
| 19385      | 316    | 19462      | 317    | 19574      | 56     | 19636      | 56     | 19698      | 57     | 19753      | 57     |
| 19387      | 316    | 19463      | 317    | 19575      | 56     | 19637      | 56     | 19699      | 57     | 19754      | 57     |
| 19388      | 316    | 19464      | 317    | 19575      | 56     | 19638      | 56     | 19700      | 57     | 19755      | 57     |
| 19389      | 316    | 19465      | 317    | 19576      | 56     | 19639      | 56     | 19701      | 57     | 19756      | 57     |
| 19390      | 316    | 19469      | 317    | 19577      | 56     | 19640      | 56     | 19701      | 57     | 19757      | 57     |
| 19391      | 316    | 19470      | 201    | 19578      | 56     | 19640      | 56     | 19702      | 57     | 19758      | 57     |
| 19392      | 316    | 19470      | 251    | 19579      | 56     | 19641      | 56     | 19703      | 57     | 19758      | 57     |
| 19393      | 317    | 19472      | 202    | 19580      | 56     | 19642      | 56     | 19703      | 57     | 19759      | 57     |

# LISTA PRODUSELOR



| Cod produs | pagina | Cod produs | pagina | Cod produs | pagina | Cod produs | pagina | Cod produs | pagina | Cod produs | pagina |
|------------|--------|------------|--------|------------|--------|------------|--------|------------|--------|------------|--------|
| 19760      | 57     | 20300      | 59     | 20489      | 61     | 20751      | 67     | 20896      | 63     | 21110      | 75     |
| 19761      | 57     | 20305      | 59     | 20490      | 61     | 20752      | 67     | 20897      | 63     | 21111      | 75     |
| 19762      | 57     | 20310      | 59     | 20491      | 61     | 20753      | 67     | 20898      | 63     | 21112      | 75     |
| 19763      | 57     | 20311      | 59     | 20492      | 61     | 20754      | 67     | 20899      | 63     | 21115      | 75     |
| 19763      | 57     | 20315      | 60     | 20493      | 61     | 20755      | 67     | 20901      | 64     | 21118      | 75     |
| 19764      | 57     | 20316      | 59     | 20494      | 61     | 20756      | 67     | 20905      | 64     | 21123      | 75     |
| 19765      | 57     | 20317      | 59     | 20495      | 61     | 20757      | 67     | 20910      | 64     | 21130      | 75     |
| 19766      | 57     | 20320      | 60     | 20496      | 61     | 20758      | 67     | 20911      | 63     | 21135      | 75     |
| 19767      | 57     | 20321      | 60     | 20508      | 67     | 20759      | 67     | 20912      | 63     | 21140      | 75     |
| 19768      | 57     | 20333      | 58     | 20510      | 67     | 20760      | 67     | 20913      | 63     | 21150      | 75     |
| 19768      | 57     | 20334      | 58     | 20511      | 67     | 20761      | 67     | 20915      | 63     | 21180      | 75     |
| 19769      | 57     | 20335      | 58     | 20512      | 67     | 20762      | 67     | 20916      | 63     | 21190      | 75     |
| 19770      | 57     | 20336      | 58     | 20513      | 67     | 20764      | 67     | 20917      | 63     | 21192      | 77     |
| 19771      | 57     | 20337      | 58     | 20514      | 67     | 20765      | 67     | 20918      | 63     | 21194      | 77     |
| 19772      | 57     | 20338      | 58     | 20515      | 67     | 20766      | 67     | 20919      | 63     | 21195      | 75     |
| 19772      | 57     | 20340      | 60     | 20516      | 67     | 20767      | 67     | 20920      | 63     | 21200      | 74     |
| 19773      | 57     | 20350      | 202    | 20520      | 67     | 20768      | 67     | 20921      | 63     | 21201      | 74     |
| 19774      | 57     | 20360      | 139    | 20521      | 67     | 20769      | 67     | 20922      | 63     | 21203      | 74     |
| 19775      | 57     | 20361      | 139    | 20522      | 67     | 20770      | 67     | 20923      | 63     | 21204      | 74     |
| 19776      | 57     | 20363      | 180    | 20523      | 67     | 20771      | 67     | 20924      | 63     | 21205      | 74     |
| 19776      | 57     | 20364      | 180    | 20524      | 67     | 20772      | 67     | 20932      | 69     | 21209      | 74     |
| 19777      | 57     | 20365      | 29     | 20525      | 67     | 20773      | 67     | 20936      | 69     | 21210      | 75     |
| 19778      | 57     | 20379      | 29     | 20526      | 67     | 20774      | 67     | 20937      | 69     | 21211      | 75     |
| 19779      | 57     | 20380      | 60     | 20673      | 67     | 20775      | 67     | 20938      | 69     | 21212      | 75     |
| 19780      | 57     | 20381      | 64     | 20674      | 67     | 20776      | 67     | 20939      | 69     | 21215      | 75     |
| 19781      | 57     | 20385      | 62     | 20675      | 67     | 20777      | 67     | 20940      | 69     | 21218      | 75     |
| 19781      | 57     | 20386      | 62     | 20676      | 67     | 20778      | 67     | 20941      | 69     | 21219      | 75     |
| 19782      | 57     | 20387      | 62     | 20677      | 67     | 20779      | 67     | 20942      | 69     | 21220      | 75     |
| 19783      | 57     | 20390      | 62     | 20678      | 67     | 20780      | 67     | 20943      | 69     | 21223      | 75     |
| 19783      | 57     | 20391      | 62     | 20680      | 67     | 20781      | 67     | 20944      | 69     | 21224      | 75     |
| 19784      | 57     | 20394      | 62     | 20682      | 67     | 20782      | 67     | 20945      | 69     | 21230      | 74     |
| 19785      | 57     | 20395      | 62     | 20684      | 67     | 20783      | 67     | 20946      | 69     | 21231      | 74     |
| 19786      | 57     | 20396      | 62     | 20685      | 67     | 20784      | 67     | 20947      | 69     | 21234      | 74     |
| 19786      | 57     | 20397      | 62     | 20686      | 67     | 20785      | 67     | 20948      | 69     | 21235      | 74     |
| 19787      | 57     | 20400      | 58     | 20687      | 67     | 20786      | 67     | 20949      | 69     | 21238      | 74     |
| 19788      | 57     | 20401      | 58     | 20688      | 67     | 20787      | 67     | 20950      | 68     | 21301      | 75     |
| 19789      | 57     | 20402      | 58     | 20690      | 67     | 20788      | 67     | 20952      | 68     | 21303      | 75     |
| 19790      | 57     | 20403      | 58     | 20691      | 67     | 20789      | 67     | 20954      | 68     | 21306      | 77     |
| 19791      | 57     | 20404      | 58     | 20692      | 67     | 20790      | 67     | 20956      | 69     | 21308      | 77     |
| 19792      | 57     | 20405      | 58     | 20694      | 67     | 20791      | 67     | 20957      | 63     | 21311      | 75     |
| 19793      | 57     | 20406      | 58     | 20696      | 67     | 20792      | 67     | 20958      | 63     | 21312      | 75     |
| 19794      | 57     | 20407      | 58     | 20697      | 67     | 20793      | 67     | 20960      | 29     | 21315      | 75     |
| 19795      | 57     | 20408      | 58     | 20698      | 67     | 20794      | 67     | 20961      | 29     | 21318      | 75     |
| 19796      | 57     | 20409      | 58     | 20724      | 63     | 20795      | 67     | 20963      | 29     | 21323      | 75     |
| 19797      | 57     | 20410      | 58     | 20725      | 63     | 20796      | 67     | 20965      | 29     | 21324      | 75     |
| 19798      | 57     | 20411      | 58     | 20726      | 63     | 20797      | 67     | 20966      | 29     | 21326      | 75     |
| 19799      | 57     | 20412      | 58     | 20727      | 63     | 20798      | 67     | 20967      | 166    | 21327      | 75     |
| 19800      | 57     | 20413      | 58     | 20728      | 63     | 20799      | 67     | 20968      | 166    | 21411      | 75     |
| 19801      | 57     | 20414      | 58     | 20729      | 63     | 20805      | 68     | 20970      | 202    | 21412      | 75     |
| 19802      | 57     | 20415      | 58     | 20730      | 63     | 20820      | 68     | 20971      | 202    | 21415      | 75     |
| 19841      | 58     | 20416      | 58     | 20731      | 63     | 20825      | 67     | 20972      | 202    | 21418      | 75     |
| 19842      | 58     | 20417      | 58     | 20732      | 63     | 20855      | 67     | 20973      | 202    | 21423      | 75     |
| 19845      | 58     | 20418      | 58     | 20733      | 63     | 20861      | 67     | 20980      | 63     | 21424      | 75     |
| 19885      | 58     | 20419      | 58     | 20734      | 63     | 20862      | 67     | 20981      | 63     | 21425      | 76     |
| 19895      | 58     | 20420      | 58     | 20735      | 63     | 20870      | 67     | 20982      | 63     | 21426      | 76     |
| 20210      | 64     | 20421      | 58     | 20736      | 63     | 20871      | 67     | 20983      | 63     | 21427      | 76     |
| 20220      | 57     | 20422      | 58     | 20737      | 63     | 20872      | 67     | 20984      | 63     | 21428      | 76     |
| 20225      | 57     | 20423      | 58     | 20738      | 63     | 20873      | 67     | 20990      | 69     | 21430      | 76     |
| 20230      | 57     | 20424      | 58     | 20739      | 63     | 20874      | 67     | 20991      | 69     | 21431      | 76     |
| 20235      | 57     | 20425      | 58     | 20740      | 63     | 20875      | 67     | 20992      | 69     | 21432      | 76     |
| 20240      | 57     | 20426      | 58     | 20741      | 63     | 20876      | 67     | 20996      | 68     | 21435      | 76     |
| 20245      | 57     | 20427      | 58     | 20742      | 150    | 20877      | 67     | 20997      | 69     | 21436      | 76     |
| 20250      | 57     | 20428      | 58     | 20743      | 29     | 20878      | 67     | 20999      | 68     | 21437      | 76     |
| 20255      | 57     | 20429      | 58     | 20743      | 149    | 20879      | 67     | 21010      | 75     | 21440      | 64     |
| 20260      | 57     | 20430      | 58     | 20744      | 29     | 20880      | 67     | 21011      | 75     | 21441      | 64     |
| 20270      | 57     | 20450      | 64     | 20745      | 29     | 20881      | 67     | 21012      | 75     | 21442      | 64     |
| 20280      | 57     | 20460      | 64     | 20748      | 67     | 20890      | 68     | 21015      | 75     | 21443      | 64     |
| 20290      | 57     | 20487      | 61     | 20749      | 67     | 20891      | 68     | 21018      | 75     | 21444      | 64     |
| 20296      | 57     | 20488      | 61     | 20750      | 67     | 20895      | 68     | 21023      | 75     | 21445      | 64     |

| Cod produs | pagina | Cod produs | pagina | Cod produs | pagina | Cod produs | pagina | Cod produs | pagina | Cod produs | pagina |
|------------|--------|------------|--------|------------|--------|------------|--------|------------|--------|------------|--------|
| 21446      | 64     | 21803      | 78     | 22012      | 81     | 22083      | 82     | 22170      | 189    | 22277      | 76     |
| 21450      | 66     | 21804      | 78     | 22013      | 81     | 22084      | 82     | 22171      | 189    | 22280      | 76     |
| 21451      | 66     | 21805      | 78     | 22014      | 81     | 22085      | 82     | 22172      | 189    | 22281      | 76     |
| 21452      | 66     | 21806      | 78     | 22015      | 81     | 22086      | 187    | 22173      | 189    | 22285      | 76     |
| 21453      | 66     | 21807      | 65     | 22016      | 81     | 22087      | 83     | 22174      | 189    | 22286      | 76     |
| 21454      | 66     | 21807      | 78     | 22017      | 81     | 22088      | 82     | 22178      | 188    | 22294      | 76     |
| 21530      | 64     | 21808      | 65     | 22018      | 81     | 22090      | 82     | 22180      | 188    | 22300      | 86     |
| 21531      | 63     | 21808      | 78     | 22019      | 81     | 22091      | 83     | 22181      | 188    | 22301      | 86     |
| 21532      | 63     | 21809      | 79     | 22020      | 81     | 22092      | 83     | 22182      | 188    | 22302      | 86     |
| 21533      | 63     | 21810      | 84     | 22021      | 81     | 22093      | 83     | 22183      | 188    | 22303      | 86     |
| 21534      | 63     | 21811      | 84     | 22022      | 81     | 22095      | 82     | 22184      | 188    | 22305      | 86     |
| 21535      | 63     | 21812      | 84     | 22023      | 81     | 22096      | 84     | 22185      | 188    | 22307      | 86     |
| 21536      | 63     | 21813      | 84     | 22024      | 81     | 22097      | 84     | 22186      | 188    | 22309      | 86     |
| 21540      | 66     | 21814      | 84     | 22025      | 81     | 22098      | 84     | 22188      | 189    | 22310      | 86     |
| 21541      | 66     | 21831      | 84     | 22026      | 81     | 22099      | 84     | 22189      | 189    | 22311      | 86     |
| 21701      | 84     | 21832      | 84     | 22027      | 81     | 22100      | 85     | 22190      | 189    | 22312      | 86     |
| 21702      | 84     | 21834      | 84     | 22028      | 81     | 22101      | 85     | 22196      | 189    | 22313      | 86     |
| 21703      | 84     | 21850      | 85     | 22029      | 81     | 22102      | 85     | 22197      | 189    | 22314      | 86     |
| 21704      | 84     | 21851      | 85     | 22030      | 81     | 22103      | 85     | 22198      | 189    | 22315      | 86     |
| 21705      | 84     | 21852      | 85     | 22031      | 81     | 22104      | 85     | 22199      | 189    | 22316      | 86     |
| 21706      | 84     | 21853      | 85     | 22032      | 82     | 22105      | 85     | 22200      | 70     | 22317      | 86     |
| 21709      | 84     | 21854      | 85     | 22033      | 187    | 22106      | 85     | 22201      | 70     | 22318      | 86     |
| 21715      | 84     | 21855      | 85     | 22034      | 187    | 22107      | 85     | 22202      | 189    | 22319      | 86     |
| 21716      | 84     | 21856      | 85     | 22035      | 187    | 22108      | 85     | 22203      | 189    | 22320      | 86     |
| 21717      | 84     | 21857      | 85     | 22036      | 187    | 22109      | 85     | 22204      | 189    | 22322      | 86     |
| 21718      | 84     | 21858      | 85     | 22037      | 80     | 22110      | 85     | 22205      | 189    | 22324      | 86     |
| 21719      | 84     | 21859      | 85     | 22038      | 80     | 22111      | 85     | 22206      | 188    | 22326      | 86     |
| 21720      | 84     | 21860      | 85     | 22039      | 81     | 22112      | 85     | 22207      | 188    | 22328      | 86     |
| 21721      | 84     | 21861      | 85     | 22040      | 81     | 22113      | 85     | 22208      | 188    | 22329      | 86     |
| 21724      | 84     | 21862      | 85     | 22041      | 83     | 22115      | 85     | 22209      | 188    | 22332      | 86     |
| 21732      | 84     | 21863      | 85     | 22042      | 83     | 22116      | 85     | 22211      | 77     | 22333      | 86     |
| 21734      | 84     | 21864      | 85     | 22043      | 83     | 22117      | 85     | 22212      | 77     | 22335      | 86     |
| 21735      | 84     | 21900      | 80     | 22044      | 83     | 22119      | 85     | 22215      | 77     | 22337      | 86     |
| 21736      | 84     | 21901      | 80     | 22045      | 84     | 22120      | 293    | 22216      | 77     | 22340      | 86     |
| 21737      | 84     | 21902      | 80     | 22046      | 84     | 22121      | 293    | 22217      | 77     | 22343      | 86     |
| 21740      | 84     | 21903      | 80     | 22047      | 84     | 22122      | 293    | 22218      | 77     | 22345      | 86     |
| 21741      | 84     | 21904      | 80     | 22048      | 84     | 22123      | 293    | 22219      | 77     | 22350      | 86     |
| 21742      | 84     | 21905      | 80     | 22049      | 84     | 22124      | 293    | 22220      | 77     | 22351      | 86     |
| 21743      | 84     | 21906      | 80     | 22050      | 84     | 22125      | 293    | 22222      | 77     | 22355      | 86     |
| 21744      | 84     | 21907      | 80     | 22051      | 84     | 22126      | 293    | 22224      | 77     | 22357      | 86     |
| 21750      | 84     | 21908      | 80     | 22052      | 84     | 22129      | 293    | 22225      | 77     | 22365      | 86     |
| 21751      | 84     | 21909      | 81     | 22053      | 84     | 22130      | 293    | 22228      | 77     | 22370      | 86     |
| 21752      | 84     | 21910      | 81     | 22054      | 84     | 22132      | 293    | 22229      | 77     | 22398      | 86     |
| 21753      | 84     | 21911      | 80     | 22055      | 84     | 22133      | 293    | 22230      | 77     | 22399      | 86     |
| 21754      | 84     | 21912      | 80     | 22056      | 84     | 22134      | 293    | 22232      | 77     | 22510      | 56     |
| 21760      | 79     | 21913      | 80     | 22057      | 84     | 22135      | 350    | 22234      | 77     | 22515      | 56     |
| 21761      | 79     | 21914      | 80     | 22058      | 81     | 22136      | 350    | 22236      | 77     | 22520      | 56     |
| 21762      | 79     | 21920      | 80     | 22059      | 81     | 22137      | 350    | 22238      | 77     | 22525      | 56     |
| 21763      | 79     | 21925      | 80     | 22060      | 83     | 22138      | 350    | 22240      | 77     | 22530      | 56     |
| 21764      | 79     | 21926      | 80     | 22061      | 83     | 22140      | 79     | 22242      | 77     | 22532      | 56     |
| 21780      | 79     | 21930      | 82     | 22062      | 83     | 22141      | 79     | 22244      | 77     | 22535      | 56     |
| 21781      | 79     | 21931      | 82     | 22063      | 83     | 22142      | 79     | 22246      | 77     | 22540      | 56     |
| 21782      | 79     | 21935      | 82     | 22064      | 83     | 22143      | 79     | 22248      | 77     | 22542      | 56     |
| 21783      | 79     | 21936      | 82     | 22065      | 83     | 22145      | 79     | 22251      | 77     | 22545      | 56     |
| 21784      | 79     | 21937      | 82     | 22066      | 83     | 22146      | 79     | 22252      | 77     | 22548      | 56     |
| 21786      | 79     | 21940      | 82     | 22067      | 85     | 22147      | 79     | 22253      | 77     | 22550      | 56     |
| 21787      | 79     | 21941      | 82     | 22070      | 83     | 22148      | 79     | 22254      | 77     | 22555      | 56     |
| 21788      | 79     | 21950      | 81     | 22071      | 83     | 22150      | 79     | 22255      | 77     | 22560      | 56     |
| 21789      | 79     | 22001      | 80     | 22072      | 83     | 22151      | 79     | 22258      | 76     | 22565      | 56     |
| 21790      | 79     | 22002      | 80     | 22073      | 83     | 22155      | 79     | 22259      | 76     | 22568      | 56     |
| 21792      | 79     | 22003      | 80     | 22074      | 83     | 22156      | 79     | 22260      | 76     | 22570      | 56     |
| 21793      | 79     | 22004      | 80     | 22075      | 85     | 22158      | 187    | 22263      | 76     | 22575      | 56     |
| 21794      | 79     | 22005      | 80     | 22076      | 85     | 22159      | 187    | 22264      | 76     | 22580      | 56     |
| 21795      | 79     | 22006      | 80     | 22077      | 85     | 22160      | 83     | 22266      | 76     | 22585      | 56     |
| 21796      | 79     | 22007      | 80     | 22078      | 187    | 22161      | 83     | 22269      | 76     | 22590      | 56     |
| 21798      | 79     | 22008      | 80     | 22079      | 187    | 22162      | 83     | 22270      | 76     | 22595      | 56     |
| 21800      | 78     | 22009      | 80     | 22080      | 187    | 22163      | 83     | 22273      | 76     | 22600      | 56     |
| 21801      | 78     | 22010      | 80     | 22081      | 187    | 22164      | 83     | 22274      | 76     | 22602      | 56     |
| 21802      | 78     | 22011      | 80     | 22082      | 187    | 22167      | 83     | 22275      | 76     | 22605      | 56     |

# LISTA PRODUSELOR



| Cod produs | pagina | Cod produs | pagina | Cod produs | pagina | Cod produs | pagina | Cod produs | pagina | Cod produs | pagina |
|------------|--------|------------|--------|------------|--------|------------|--------|------------|--------|------------|--------|
| 22610      | 56     | 23658      | 209    | 23973      | 183    | 24111      | 190    | 24197      | 93     | 24676      | 72     |
| 22615      | 56     | 23660      | 210    | 23974      | 183    | 24114      | 191    | 24301      | 90     | 24677      | 72     |
| 22620      | 56     | 23661      | 209    | 23975      | 183    | 24115      | 191    | 24302      | 90     | 24678      | 72     |
| 22625      | 56     | 23664      | 209    | 23976      | 183    | 24118      | 93     | 24303      | 90     | 24680      | 276    |
| 22630      | 56     | 23670      | 203    | 23977      | 183    | 24119      | 93     | 24304      | 90     | 24690      | 202    |
| 22701      | 82     | 23671      | 203    | 23978      | 183    | 24120      | 93     | 24305      | 90     | 24691      | 202    |
| 22702      | 82     | 23672      | 203    | 23979      | 183    | 24121      | 190    | 24306      | 90     | 24695      | 202    |
| 22703      | 82     | 23673      | 203    | 23985      | 183    | 24122      | 190    | 24308      | 90     | 24700      | 72     |
| 22704      | 82     | 23674      | 203    | 23986      | 183    | 24124      | 190    | 24310      | 90     | 24701      | 72     |
| 22705      | 82     | 23675      | 203    | 23987      | 183    | 24125      | 190    | 24312      | 91     | 24702      | 72     |
| 22706      | 82     | 23676      | 203    | 23988      | 183    | 24126      | 190    | 24313      | 91     | 24703      | 72     |
| 22707      | 82     | 23677      | 203    | 23989      | 183    | 24128      | 193    | 24314      | 91     | 24704      | 72     |
| 23270      | 239    | 23678      | 203    | 24000      | 183    | 24130      | 192    | 24315      | 91     | 24705      | 72     |
| 23400      | 212    | 23679      | 203    | 24001      | 183    | 24131      | 192    | 24316      | 91     | 24706      | 65     |
| 23401      | 212    | 23680      | 203    | 24005      | 183    | 24132      | 134    | 24320      | 87     | 24710      | 73     |
| 23402      | 212    | 23681      | 203    | 24007      | 182    | 24133      | 192    | 24321      | 87     | 24712      | 65     |
| 23406      | 212    | 23682      | 203    | 24008      | 183    | 24134      | 191    | 24322      | 87     | 24713      | 65     |
| 23407      | 212    | 23683      | 203    | 24010      | 182    | 24135      | 192    | 24325      | 91     | 24714      | 65     |
| 23410      | 212    | 23684      | 203    | 24015      | 182    | 24136      | 192    | 24410      | 60     | 24715      | 65     |
| 23411      | 212    | 23685      | 203    | 24017      | 182    | 24137      | 192    | 24411      | 60     | 24716      | 65     |
| 23412      | 212    | 23730      | 168    | 24020      | 182    | 24140      | 192    | 24412      | 60     | 24717      | 69     |
| 23415      | 212    | 23731      | 168    | 24030      | 182    | 24141      | 192    | 24415      | 65     | 24718      | 69     |
| 23416      | 212    | 23732      | 168    | 24035      | 183    | 24142      | 192    | 24419      | 60     | 24719      | 69     |
| 23417      | 212    | 23734      | 168    | 24036      | 183    | 24143      | 191    | 24420      | 60     | 24720      | 65     |
| 23420      | 205    | 23735      | 168    | 24038      | 183    | 24144      | 191    | 24422      | 60     | 24721      | 65     |
| 23506      | 204    | 23736      | 168    | 24039      | 183    | 24145      | 191    | 24425      | 60     | 24722      | 65     |
| 23507      | 204    | 23760      | 185    | 24040      | 183    | 24147      | 191    | 24429      | 60     | 24723      | 69     |
| 23508      | 204    | 23761      | 185    | 24041      | 183    | 24148      | 192    | 24432      | 60     | 24725      | 70     |
| 23515      | 204    | 23762      | 185    | 24042      | 183    | 24149      | 191    | 24435      | 60     | 24726      | 70     |
| 23520      | 204    | 23763      | 185    | 24043      | 183    | 24150      | 192    | 24437      | 60     | 24727      | 290    |
| 23525      | 204    | 23764      | 185    | 24045      | 89     | 24151      | 192    | 24444      | 60     | 24728      | 290    |
| 23530      | 204    | 23800      | 184    | 24050      | 91     | 24152      | 193    | 24451      | 60     | 24729      | 290    |
| 23531      | 204    | 23840      | 322    | 24055      | 88     | 24152      | 315    | 24457      | 60     | 24730      | 69     |
| 23551      | 204    | 23845      | 323    | 24055      | 277    | 24153      | 190    | 24464      | 60     | 24731      | 69     |
| 23560      | 204    | 23846      | 323    | 24060      | 88     | 24155      | 194    | 24468      | 60     | 24732      | 69     |
| 23561      | 204    | 23847      | 323    | 24061      | 88     | 24156      | 194    | 24476      | 60     | 24734      | 73     |
| 23562      | 204    | 23875      | 223    | 24062      | 88     | 24158      | 194    | 24483      | 60     | 24735      | 70     |
| 23563      | 204    | 23875      | 357    | 24063      | 88     | 24159      | 194    | 24620      | 71     | 24736      | 70     |
| 23564      | 204    | 23904      | 185    | 24064      | 88     | 24159      | 293    | 24621      | 71     | 24737      | 70     |
| 23565      | 204    | 23906      | 185    | 24065      | 88     | 24160      | 93     | 24622      | 71     | 24738      | 70     |
| 23566      | 204    | 23908      | 185    | 24066      | 88     | 24161      | 93     | 24623      | 71     | 24739      | 70     |
| 23570      | 203    | 23910      | 185    | 24067      | 88     | 24162      | 93     | 24624      | 71     | 24740      | 70     |
| 23571      | 203    | 23912      | 185    | 24068      | 88     | 24163      | 93     | 24627      | 71     | 24741      | 70     |
| 23572      | 203    | 23914      | 185    | 24069      | 88     | 24164      | 93     | 24630      | 71     | 24743      | 70     |
| 23573      | 203    | 23920      | 184    | 24070      | 88     | 24165      | 93     | 24633      | 71     | 24745      | 70     |
| 23574      | 203    | 23922      | 184    | 24071      | 88     | 24166      | 93     | 24636      | 71     | 24746      | 70     |
| 23585      | 203    | 23923      | 184    | 24072      | 88     | 24167      | 93     | 24638      | 71     | 24747      | 70     |
| 23587      | 203    | 23924      | 184    | 24073      | 88     | 24168      | 93     | 24640      | 71     | 24748      | 70     |
| 23589      | 203    | 23925      | 184    | 24074      | 88     | 24169      | 93     | 24642      | 71     | 24749      | 70     |
| 23591      | 203    | 23927      | 184    | 24075      | 88     | 24170      | 190    | 24643      | 71     | 24750      | 61     |
| 23595      | 204    | 23928      | 184    | 24076      | 88     | 24171      | 192    | 24647      | 79     | 24751      | 61     |
| 23598      | 204    | 23945      | 184    | 24077      | 88     | 24173      | 192    | 24648      | 79     | 24752      | 290    |
| 23600      | 205    | 23950      | 183    | 24078      | 88     | 24174      | 194    | 24649      | 79     | 24753      | 290    |
| 23601      | 205    | 23951      | 183    | 24080      | 89     | 24175      | 194    | 24650      | 72     | 24755      | 66     |
| 23602      | 205    | 23952      | 183    | 24081      | 89     | 24176      | 194    | 24651      | 71     | 24756      | 66     |
| 23605      | 205    | 23953      | 183    | 24082      | 89     | 24177      | 194    | 24652      | 71     | 24757      | 69     |
| 23607      | 205    | 23954      | 183    | 24083      | 89     | 24178      | 194    | 24655      | 73     | 24758      | 69     |
| 23620      | 205    | 23955      | 183    | 24084      | 89     | 24180      | 93     | 24658      | 73     | 24759      | 69     |
| 23625      | 203    | 23960      | 185    | 24085      | 89     | 24181      | 194    | 24661      | 72     | 24760      | 72     |
| 23626      | 203    | 23961      | 185    | 24086      | 89     | 24185      | 93     | 24663      | 72     | 24761      | 72     |
| 23628      | 203    | 23962      | 185    | 24087      | 89     | 24186      | 93     | 24665      | 82     | 24762      | 72     |
| 23630      | 203    | 23963      | 185    | 24098      | 89     | 24187      | 93     | 24666      | 82     | 24763      | 72     |
| 23632      | 203    | 23964      | 185    | 24099      | 89     | 24188      | 93     | 24667      | 82     | 24764      | 72     |
| 23635      | 203    | 23965      | 185    | 24100      | 190    | 24189      | 93     | 24670      | 72     | 24765      | 72     |
| 23637      | 204    | 23966      | 185    | 24102      | 190    | 24190      | 194    | 24671      | 72     | 24766      | 72     |
| 23650      | 210    | 23967      | 185    | 24104      | 190    | 24190      | 293    | 24672      | 72     | 24767      | 72     |
| 23652      | 208    | 23970      | 183    | 24108      | 93     | 24192      | 93     | 24673      | 72     | 24768      | 72     |
| 23655      | 210    | 23971      | 183    | 24109      | 93     | 24195      | 93     | 24674      | 72     | 24769      | 72     |
| 23657      | 208    | 23972      | 183    | 24110      | 190    | 24196      | 93     | 24675      | 72     | 24770      | 70     |

| Cod produs | pagina | Cod produs | pagina | Cod produs | pagina | Cod produs | pagina | Cod produs | pagina | Cod produs | pagina |
|------------|--------|------------|--------|------------|--------|------------|--------|------------|--------|------------|--------|
| 24771      | 70     | 25206      | 305    | 28032      | 11     | 31082      | 245    | 31502      | 252    | 32166      | 248    |
| 24772      | 70     | 25212      | 305    | 28035      | 13     | 31091      | 244    | 31503      | 252    | 32167      | 248    |
| 24773      | 70     | 25215      | 305    | 28040      | 12     | 31101      | 244    | 31505      | 247    | 32168      | 248    |
| 24774      | 70     | 25220      | 305    | 28045      | 12     | 31111      | 244    | 31506      | 247    | 32169      | 248    |
| 24775      | 71     | 25224      | 305    | 28050      | 14     | 31121      | 244    | 31507      | 247    | 32170      | 247    |
| 24776      | 72     | 25230      | 305    | 28055      | 14     | 31131      | 244    | 31510      | 247    | 32171      | 248    |
| 24777      | 71     | 25240      | 305    | 28060      | 17     | 31132      | 244    | 31511      | 247    | 32172      | 248    |
| 24778      | 71     | 25248      | 305    | 28061      | 17     | 31140      | 244    | 31512      | 247    | 32173      | 247    |
| 24779      | 72     | 25260      | 305    | 28065      | 17     | 31141      | 244    | 31513      | 247    | 32174      | 248    |
| 24780      | 73     | 25296      | 305    | 28070      | 10     | 31142      | 244    | 31514      | 247    | 32176      | 248    |
| 24781      | 73     | 25350      | 305    | 28075      | 15     | 31143      | 244    | 31515      | 247    | 32186      | 248    |
| 24782      | 73     | 25369      | 305    | 28076      | 18     | 31144      | 244    | 31517      | 247    | 32196      | 248    |
| 24783      | 73     | 25370      | 305    | 28080      | 19     | 31145      | 244    | 31519      | 252    | 32206      | 248    |
| 24784      | 73     | 25371      | 305    | 28081      | 19     | 31146      | 244    | 31520      | 249    | 32216      | 248    |
| 24785      | 73     | 25372      | 305    | 28083      | 19     | 31148      | 244    | 31521      | 249    | 32226      | 248    |
| 24786      | 73     | 25373      | 305    | 28085      | 19     | 31150      | 245    | 31522      | 249    | 32234      | 248    |
| 24787      | 73     | 25374      | 305    | 28086      | 19     | 31151      | 245    | 31523      | 249    | 32240      | 248    |
| 24788      | 73     | 25376      | 305    | 28090      | 20     | 31155      | 245    | 31524      | 249    | 32265      | 250    |
| 24789      | 73     | 25378      | 305    | 28101      | 21     | 31218      | 247    | 31541      | 249    | 32268      | 251    |
| 24790      | 72     | 25379      | 305    | 28102      | 20     | 31220      | 246    | 31551      | 249    | 32269      | 251    |
| 24791      | 72     | 25380      | 305    | 28103      | 20     | 31221      | 246    | 31552      | 249    | 32270      | 250    |
| 24792      | 72     | 25400      | 305    | 28104      | 21     | 31222      | 246    | 31553      | 249    | 32273      | 250    |
| 24793      | 72     | 25410      | 305    | 28210      | 28     | 31231      | 246    | 31555      | 249    | 32283      | 250    |
| 24794      | 72     | 26028      | 111    | 28213      | 28     | 31232      | 246    | 31556      | 249    | 32285      | 250    |
| 24795      | 71     | 26201      | 113    | 28215      | 27     | 31233      | 246    | 31557      | 249    | 32293      | 250    |
| 24796      | 72     | 26203      | 112    | 28218      | 28     | 31234      | 246    | 31558      | 249    | 32295      | 251    |
| 24797      | 71     | 26204      | 113    | 28220      | 25     | 31235      | 246    | 31559      | 249    | 32296      | 251    |
| 24798      | 73     | 26205      | 112    | 28221      | 23     | 31270      | 246    | 31601      | 253    | 32297      | 251    |
| 24799      | 71     | 26209      | 114    | 28223      | 28     | 31271      | 246    | 31602      | 253    | 32298      | 251    |
| 25001      | 305    | 26211      | 113    | 28225      | 24     | 31280      | 246    | 31603      | 253    | 32301      | 251    |
| 25002      | 305    | 26216      | 114    | 28228      | 28     | 31281      | 246    | 31610      | 249    | 32302      | 251    |
| 25003      | 305    | 26217      | 114    | 28229      | 28     | 31320      | 247    | 31641      | 253    | 32311      | 255    |
| 25004      | 305    | 26218      | 114    | 28230      | 26     | 31322      | 247    | 31651      | 253    | 32312      | 254    |
| 25005      | 305    | 26219      | 114    | 28233      | 28     | 31330      | 246    | 31655      | 253    | 32313      | 251    |
| 25006      | 305    | 26520      | 115    | 28240      | 36     | 31332      | 246    | 32001      | 250    | 32314      | 254    |
| 25009      | 305    | 26521      | 115    | 28267      | 29     | 31334      | 246    | 32002      | 250    | 32315      | 255    |
| 25012      | 305    | 26705      | 228    | 28275      | 50     | 31340      | 246    | 32003      | 250    | 32316      | 255    |
| 25015      | 305    | 26706      | 228    | 28278      | 50     | 31341      | 246    | 32013      | 250    | 32317      | 254    |
| 25016      | 305    | 26707      | 228    | 28280      | 50     | 31343      | 246    | 32014      | 250    | 32318      | 255    |
| 25020      | 305    | 26720      | 228    | 28282      | 50     | 31360      | 246    | 32015      | 250    | 32319      | 255    |
| 25024      | 305    | 26721      | 228    | 28340      | 37     | 31362      | 246    | 32016      | 250    | 32320      | 254    |
| 25025      | 305    | 26722      | 228    | 28342      | 37     | 31380      | 246    | 32018      | 250    | 32321      | 255    |
| 25030      | 305    | 26730      | 272    | 28345      | 37     | 31382      | 246    | 32020      | 250    | 32322      | 255    |
| 25040      | 305    | 26731      | 272    | 28346      | 37     | 31390      | 246    | 32021      | 250    | 32323      | 255    |
| 25048      | 305    | 26735      | 272    | 30003      | 256    | 31392      | 246    | 32022      | 253    | 32324      | 255    |
| 25060      | 305    | 26736      | 272    | 30003      | 259    | 31400      | 246    | 32023      | 253    | 32325      | 255    |
| 25096      | 305    | 26740      | 273    | 30004      | 256    | 31402      | 246    | 32024      | 250    | 32326      | 255    |
| 25150      | 305    | 26775      | 292    | 30004      | 259    | 31403      | 246    | 32026      | 250    | 32327      | 254    |
| 25153      | 305    | 26780      | 273    | 30005      | 256    | 31404      | 246    | 32037      | 251    | 32328      | 255    |
| 25155      | 305    | 26781      | 273    | 30005      | 259    | 31452      | 253    | 32038      | 251    | 32329      | 254    |
| 25160      | 305    | 26782      | 273    | 30007      | 256    | 31453      | 253    | 32040      | 253    | 32330      | 255    |
| 25162      | 305    | 26783      | 273    | 30007      | 259    | 31454      | 253    | 32041      | 253    | 32331      | 255    |
| 25163      | 305    | 26973      | 216    | 31005      | 245    | 31455      | 247    | 32042      | 253    | 32332      | 254    |
| 25164      | 305    | 26974      | 216    | 31006      | 245    | 31456      | 247    | 32043      | 253    | 32333      | 254    |
| 25167      | 305    | 26975      | 216    | 31007      | 245    | 31461      | 248    | 32044      | 253    | 32335      | 255    |
| 25169      | 305    | 26976      | 216    | 31008      | 245    | 31467      | 248    | 32050      | 253    | 32337      | 254    |
| 25170      | 305    | 26977      | 216    | 31009      | 245    | 31468      | 248    | 32051      | 253    | 32338      | 254    |
| 25171      | 305    | 28000      | 4      | 31011      | 245    | 31471      | 248    | 32052      | 253    | 33168      | 254    |
| 25179      | 305    | 28001      | 5      | 31021      | 245    | 31481      | 248    | 32053      | 253    | 33275      | 296    |
| 25180      | 305    | 28002      | 5      | 31031      | 245    | 31491      | 248    | 32060      | 250    | 34005      | 256    |
| 25181      | 305    | 28003      | 6      | 31041      | 245    | 31493      | 248    | 32062      | 250    | 34006      | 256    |
| 25182      | 305    | 28004      | 6      | 31051      | 245    | 31494      | 248    | 32064      | 250    | 34007      | 256    |
| 25183      | 305    | 28005      | 7      | 31052      | 245    | 31495      | 248    | 32066      | 250    | 34027      | 255    |
| 25184      | 305    | 28006      | 7      | 31053      | 245    | 31496      | 248    | 32089      | 251    | 34028      | 255    |
| 25186      | 305    | 28007      | 8      | 31061      | 245    | 31497      | 252    | 32161      | 248    | 34033      | 260    |
| 25188      | 305    | 28008      | 8      | 31062      | 245    | 31498      | 248    | 32162      | 248    | 34041      | 256    |
| 25189      | 305    | 28021      | 9      | 31071      | 245    | 31499      | 248    | 32163      | 248    | 34051      | 256    |
| 25190      | 305    | 28025      | 9      | 31072      | 245    | 31500      | 248    | 32164      | 248    | 34053      | 256    |
| 25195      | 305    | 28030      | 11     | 31081      | 245    | 31501      | 252    | 32165      | 248    | 34061      | 256    |



# LISTA PRODUSELOR



| Cod produs | pagina | Cod produs | pagina | Cod produs | pagina | Cod produs | pagina | Cod produs | pagina | Cod produs | pagina |
|------------|--------|------------|--------|------------|--------|------------|--------|------------|--------|------------|--------|
| 34071      | 256    | 34405      | 258    | 35082      | 263    | 35345      | 40     | 36130      | 277    | 37115      | 291    |
| 34081      | 256    | 34406      | 259    | 35085      | 262    | 35345      | 286    | 36136      | 277    | 37117      | 278    |
| 34091      | 256    | 34407      | 259    | 35086      | 262    | 35346      | 41     | 36138      | 277    | 37119      | 291    |
| 34101      | 256    | 34409      | 259    | 35087      | 262    | 35346      | 288    | 36139      | 277    | 37120      | 291    |
| 34111      | 256    | 34410      | 259    | 35091      | 262    | 35347      | 41     | 36140      | 277    | 37121      | 296    |
| 34115      | 256    | 34411      | 259    | 35092      | 262    | 35347      | 288    | 36145      | 274    | 37122      | 296    |
| 34116      | 256    | 34412      | 259    | 35093      | 262    | 35348      | 40     | 36160      | 274    | 37123      | 364    |
| 34117      | 256    | 34413      | 259    | 35094      | 263    | 35348      | 286    | 36175      | 274    | 37124      | 364    |
| 34121      | 256    | 34414      | 259    | 35095      | 263    | 35360      | 46     | 36190      | 274    | 37125      | 282    |
| 34122      | 256    | 34415      | 258    | 35096      | 263    | 35361      | 46     | 36191      | 274    | 37126      | 282    |
| 34132      | 256    | 34416      | 258    | 35103      | 264    | 35362      | 46     | 36195      | 277    | 37127      | 282    |
| 34142      | 256    | 34417      | 259    | 35113      | 264    | 35500      | 266    | 36199      | 274    | 37129      | 364    |
| 34152      | 256    | 34418      | 259    | 35123      | 264    | 35501      | 266    | 36200      | 274    | 37130      | 281    |
| 34153      | 256    | 34419      | 258    | 35125      | 264    | 35502      | 266    | 36300      | 209    | 37131      | 281    |
| 34154      | 256    | 34420      | 258    | 35126      | 264    | 35503      | 266    | 36308      | 292    | 37132      | 281    |
| 34155      | 256    | 34421      | 259    | 35127      | 264    | 35504      | 266    | 36310      | 273    | 37135      | 231    |
| 34156      | 256    | 34422      | 259    | 35142      | 262    | 35505      | 266    | 36312      | 292    | 37139      | 231    |
| 34157      | 256    | 34423      | 259    | 35300      | 38     | 35506      | 266    | 36318      | 283    | 37140      | 231    |
| 34158      | 256    | 34424      | 259    | 35300      | 261    | 35507      | 266    | 36319      | 283    | 37141      | 231    |
| 34159      | 256    | 34425      | 259    | 35305      | 39     | 35508      | 266    | 36325      | 283    | 37142      | 231    |
| 34160      | 256    | 34426      | 259    | 35305      | 262    | 35510      | 266    | 36326      | 16     | 37143      | 231    |
| 34200      | 252    | 34428      | 259    | 35310      | 38     | 35511      | 266    | 36326      | 283    | 37144      | 231    |
| 34201      | 252    | 34429      | 259    | 35310      | 261    | 35512      | 266    | 36328      | 16     | 37145      | 231    |
| 34202      | 252    | 34439      | 258    | 35311      | 38     | 35514      | 266    | 36329      | 16     | 37148      | 282    |
| 34203      | 252    | 34440      | 258    | 35311      | 261    | 35515      | 266    | 36410      | 208    | 37149      | 282    |
| 34221      | 260    | 34441      | 258    | 35315      | 39     | 35516      | 266    | 37005      | 302    | 37150      | 282    |
| 34223      | 260    | 34442      | 258    | 35315      | 262    | 35517      | 266    | 37006      | 279    | 37151      | 282    |
| 34231      | 260    | 34443      | 258    | 35316      | 38     | 35518      | 267    | 37006      | 279    | 37152      | 282    |
| 34235      | 260    | 34445      | 258    | 35316      | 261    | 35519      | 267    | 37007      | 279    | 37153      | 282    |
| 34237      | 260    | 34446      | 258    | 35317      | 38     | 35524      | 267    | 37007      | 279    | 37154      | 282    |
| 34238      | 260    | 34447      | 258    | 35317      | 261    | 35525      | 267    | 37008      | 279    | 37155      | 280    |
| 34241      | 260    | 34448      | 259    | 35318      | 38     | 35527      | 267    | 37009      | 279    | 37156      | 280    |
| 34243      | 260    | 34449      | 258    | 35318      | 261    | 35532      | 267    | 37011      | 278    | 37157      | 280    |
| 34251      | 260    | 34450      | 258    | 35319      | 38     | 35533      | 267    | 37012      | 279    | 37158      | 282    |
| 34261      | 260    | 34451      | 258    | 35319      | 261    | 35539      | 267    | 37021      | 278    | 37162      | 281    |
| 34262      | 260    | 34452      | 259    | 35320      | 50     | 35540      | 267    | 37025      | 278    | 37166      | 273    |
| 34265      | 260    | 34453      | 258    | 35322      | 50     | 35542      | 267    | 37025      | 278    | 37170      | 281    |
| 34271      | 252    | 34454      | 258    | 35323      | 42     | 35552      | 267    | 37026      | 278    | 37171      | 281    |
| 34272      | 252    | 34455      | 259    | 35323      | 289    | 35553      | 267    | 37026      | 278    | 37172      | 281    |
| 34273      | 252    | 34456      | 259    | 35325      | 42     | 35555      | 267    | 37028      | 278    | 37173      | 282    |
| 34274      | 252    | 34457      | 259    | 35325      | 289    | 35603      | 269    | 37028      | 278    | 37174      | 282    |
| 34275      | 252    | 34458      | 259    | 35326      | 42     | 35604      | 269    | 37029      | 278    | 37175      | 281    |
| 34276      | 252    | 34480      | 258    | 35326      | 289    | 35605      | 269    | 37029      | 278    | 37176      | 281    |
| 34280      | 252    | 34481      | 258    | 35327      | 42     | 35833      | 52     | 37031      | 253    | 37177      | 282    |
| 34281      | 252    | 34482      | 258    | 35327      | 289    | 35845      | 52     | 37041      | 253    | 37178      | 282    |
| 34282      | 252    | 34485      | 258    | 35328      | 42     | 35850      | 52     | 37050      | 278    | 37185      | 281    |
| 34283      | 252    | 34486      | 258    | 35328      | 42     | 36014      | 276    | 37051      | 253    | 37186      | 281    |
| 34284      | 252    | 34490      | 259    | 35328      | 289    | 36024      | 276    | 37052      | 278    | 37187      | 281    |
| 34285      | 252    | 34491      | 259    | 35328      | 289    | 36034      | 276    | 37053      | 278    | 37188      | 281    |
| 34300      | 292    | 34496      | 259    | 35329      | 42     | 36035      | 276    | 37054      | 278    | 37189      | 281    |
| 34301      | 252    | 34500      | 260    | 35329      | 42     | 36036      | 276    | 37055      | 278    | 37190      | 281    |
| 34303      | 292    | 35006      | 263    | 35329      | 289    | 36046      | 276    | 37065      | 284    | 37192      | 281    |
| 34304      | 252    | 35007      | 263    | 35329      | 289    | 36056      | 277    | 37066      | 284    | 37195      | 282    |
| 34305      | 252    | 35011      | 264    | 35330      | 40     | 36057      | 277    | 37067      | 284    | 37196      | 282    |
| 34305      | 292    | 35012      | 263    | 35330      | 287    | 36058      | 277    | 37068      | 284    | 37197      | 282    |
| 34306      | 252    | 35013      | 263    | 35331      | 41     | 36059      | 277    | 37069      | 284    | 37198      | 282    |
| 34306      | 292    | 35015      | 264    | 35331      | 288    | 36076      | 275    | 37070      | 284    | 37199      | 282    |
| 34307      | 252    | 35021      | 264    | 35332      | 41     | 36077      | 275    | 37094      | 284    | 37200      | 280    |
| 34307      | 292    | 35023      | 262    | 35332      | 288    | 36080      | 275    | 37095      | 284    | 37201      | 280    |
| 34308      | 252    | 35038      | 262    | 35333      | 41     | 36081      | 275    | 37096      | 284    | 37202      | 280    |
| 34308      | 292    | 35048      | 264    | 35333      | 288    | 36082      | 275    | 37097      | 284    | 37203      | 280    |
| 34315      | 293    | 35058      | 262    | 35334      | 41     | 36085      | 275    | 37098      | 284    | 37204      | 280    |
| 34316      | 131    | 35059      | 263    | 35334      | 288    | 36086      | 275    | 37101      | 253    | 37205      | 280    |
| 34316      | 293    | 35068      | 264    | 35335      | 42     | 36087      | 275    | 37102      | 280    | 37210      | 280    |
| 34400      | 258    | 35069      | 263    | 35335      | 289    | 36102      | 275    | 37105      | 280    | 37211      | 280    |
| 34401      | 258    | 35070      | 263    | 35336      | 41     | 36103      | 275    | 37106      | 280    | 37212      | 280    |
| 34402      | 259    | 35078      | 263    | 35336      | 288    | 36105      | 275    | 37107      | 280    | 37216      | 291    |
| 34403      | 259    | 35079      | 263    | 35344      | 41     | 36126      | 277    | 37111      | 253    | 37217      | 291    |
| 34404      | 258    | 35081      | 263    | 35344      | 287    | 36128      | 277    | 37114      | 291    | 37218      | 291    |

| Cod produs | pagina | Cod produs | pagina | Cod produs | pagina | Cod produs | pagina | Cod produs | pagina | Cod produs | pagina |
|------------|--------|------------|--------|------------|--------|------------|--------|------------|--------|------------|--------|
| 37220      | 280    | 37344      | 236    | 38022      | 299    | 38949      | 224    | 39217      | 290    | 42179      | 353    |
| 37230      | 292    | 37345      | 236    | 38024      | 297    | 38950      | 290    | 39218      | 290    | 42180      | 354    |
| 37231      | 292    | 37350      | 235    | 38025      | 298    | 38951      | 290    | 39219      | 290    | 42181      | 354    |
| 37232      | 292    | 37500      | 267    | 38026      | 279    | 38952      | 290    | 39238      | 292    | 42182      | 354    |
| 37233      | 292    | 37501      | 267    | 38027      | 297    | 38953      | 290    | 39240      | 290    | 42185      | 354    |
| 37234      | 292    | 37505      | 267    | 38028      | 297    | 38954      | 290    | 39241      | 290    | 42186      | 354    |
| 37235      | 292    | 37506      | 267    | 38030      | 299    | 38955      | 224    | 39242      | 290    | 42187      | 354    |
| 37236      | 291    | 37509      | 268    | 38031      | 299    | 38956      | 224    | 39243      | 290    | 42188      | 354    |
| 37237      | 291    | 37510      | 268    | 38032      | 297    | 38957      | 224    | 39244      | 290    | 42190      | 224    |
| 37238      | 291    | 37511      | 268    | 38042      | 279    | 38958      | 224    | 39245      | 292    | 42190      | 354    |
| 37239      | 291    | 37512      | 268    | 38045      | 279    | 38959      | 224    | 40050      | 353    | 42201      | 355    |
| 37243      | 303    | 37515      | 268    | 38050      | 223    | 38960      | 224    | 40051      | 353    | 42202      | 355    |
| 37244      | 303    | 37516      | 268    | 38052      | 223    | 38961      | 224    | 40052      | 353    | 42203      | 355    |
| 37245      | 303    | 37517      | 268    | 38054      | 223    | 38963      | 226    | 40053      | 353    | 42207      | 355    |
| 37246      | 303    | 37518      | 268    | 38055      | 223    | 38964      | 225    | 40054      | 353    | 42208      | 355    |
| 37247      | 303    | 37527      | 268    | 38060      | 223    | 38965      | 225    | 40055      | 353    | 42209      | 355    |
| 37248      | 303    | 37530      | 268    | 38063      | 223    | 38966      | 225    | 40056      | 353    | 42210      | 355    |
| 37250      | 303    | 37532      | 268    | 38065      | 223    | 38968      | 224    | 40057      | 353    | 42211      | 355    |
| 37251      | 303    | 37533      | 268    | 38095      | 223    | 38969      | 226    | 40058      | 353    | 42212      | 355    |
| 37252      | 303    | 37539      | 269    | 38096      | 223    | 38970      | 290    | 40059      | 353    | 42213      | 355    |
| 37253      | 303    | 37541      | 269    | 38097      | 223    | 38971      | 290    | 40060      | 353    | 42214      | 355    |
| 37255      | 225    | 37545      | 307    | 38895      | 284    | 38972      | 226    | 40075      | 353    | 42217      | 355    |
| 37256      | 225    | 37546      | 307    | 38896      | 284    | 38973      | 226    | 40076      | 353    | 42218      | 355    |
| 37257      | 225    | 37549      | 210    | 38899      | 284    | 38975      | 226    | 40077      | 353    | 42219      | 355    |
| 37258      | 225    | 37553      | 212    | 38900      | 284    | 38980      | 224    | 40100      | 352    | 42220      | 355    |
| 37259      | 225    | 37560      | 209    | 38901      | 285    | 38981      | 224    | 40120      | 352    | 42221      | 355    |
| 37263      | 225    | 37564      | 269    | 38902      | 285    | 38985      | 226    | 41050      | 352    | 42228      | 355    |
| 37264      | 225    | 37570      | 192    | 38903      | 285    | 38990      | 225    | 41080      | 352    | 42229      | 355    |
| 37266      | 225    | 37570      | 209    | 38904      | 285    | 38991      | 225    | 41081      | 352    | 42230      | 355    |
| 37267      | 225    | 37611      | 53     | 38905      | 285    | 38995      | 225    | 41082      | 352    | 42244      | 355    |
| 37268      | 225    | 37615      | 53     | 38906      | 285    | 39000      | 296    | 41083      | 352    | 42248      | 355    |
| 37270      | 225    | 37616      | 53     | 38907      | 284    | 39001      | 296    | 41100      | 352    | 42249      | 355    |
| 37271      | 225    | 37647      | 218    | 38908      | 284    | 39002      | 296    | 41101      | 352    | 42251      | 355    |
| 37272      | 225    | 37660      | 306    | 38909      | 284    | 39003      | 296    | 41102      | 352    | 42252      | 355    |
| 37273      | 225    | 37730      | 53     | 38910      | 285    | 39005      | 296    | 41103      | 352    | 42253      | 355    |
| 37275      | 225    | 37731      | 53     | 38911      | 285    | 39010      | 296    | 41120      | 352    | 42255      | 355    |
| 37280      | 226    | 37732      | 53     | 38912      | 285    | 39012      | 296    | 41121      | 352    | 42256      | 355    |
| 37281      | 226    | 37733      | 53     | 38913      | 285    | 39014      | 296    | 41122      | 352    | 42257      | 355    |
| 37285      | 282    | 37740      | 53     | 38914      | 285    | 39020      | 296    | 41123      | 352    | 42260      | 355    |
| 37286      | 282    | 37741      | 53     | 38915      | 285    | 39021      | 296    | 41150      | 352    | 42261      | 355    |
| 37287      | 282    | 37744      | 53     | 38916      | 285    | 39045      | 296    | 41151      | 352    | 42312      | 291    |
| 37288      | 282    | 37745      | 53     | 38917      | 285    | 39065      | 296    | 41152      | 352    | 42312      | 354    |
| 37289      | 282    | 37746      | 53     | 38918      | 285    | 39090      | 296    | 41153      | 352    | 42365      | 222    |
| 37290      | 303    | 37747      | 53     | 38919      | 279    | 39145      | 296    | 42101      | 352    | 42366      | 222    |
| 37291      | 303    | 37750      | 53     | 38920      | 279    | 39165      | 296    | 42102      | 352    | 42367      | 222    |
| 37295      | 226    | 37751      | 53     | 38923      | 279    | 39190      | 296    | 42103      | 352    | 42368      | 222    |
| 37296      | 226    | 37760      | 53     | 38924      | 225    | 39192      | 296    | 42115      | 291    | 42420      | 291    |
| 37297      | 226    | 37761      | 53     | 38925      | 224    | 39192      | 323    | 42120      | 291    | 43050      | 358    |
| 37300      | 235    | 38000      | 298    | 38926      | 226    | 39193      | 296    | 42150      | 353    | 43058      | 358    |
| 37301      | 235    | 38001      | 297    | 38927      | 224    | 39193      | 323    | 42151      | 353    | 43060      | 358    |
| 37302      | 235    | 38002      | 298    | 38928      | 225    | 39194      | 223    | 42152      | 353    | 43068      | 358    |
| 37303      | 235    | 38003      | 298    | 38929      | 225    | 39195      | 223    | 42153      | 353    | 43071      | 358    |
| 37308      | 236    | 38004      | 299    | 38930      | 226    | 39196      | 223    | 42155      | 353    | 43072      | 358    |
| 37309      | 236    | 38005      | 299    | 38931      | 224    | 39197      | 223    | 42156      | 353    | 43077      | 358    |
| 37310      | 235    | 38006      | 298    | 38932      | 224    | 39198      | 223    | 42157      | 353    | 43082      | 358    |
| 37311      | 235    | 38007      | 298    | 38933      | 226    | 39199      | 223    | 42158      | 353    | 43083      | 358    |
| 37317      | 313    | 38008      | 298    | 38934      | 225    | 39200      | 223    | 42160      | 353    | 43084      | 358    |
| 37320      | 235    | 38009      | 298    | 38935      | 226    | 39201      | 223    | 42161      | 353    | 43086      | 358    |
| 37321      | 235    | 38010      | 298    | 38937      | 226    | 39202      | 223    | 42162      | 353    | 43087      | 359    |
| 37325      | 234    | 38012      | 297    | 38939      | 226    | 39203      | 223    | 42163      | 353    | 43089      | 359    |
| 37326      | 234    | 38013      | 297    | 38940      | 226    | 39204      | 223    | 42170      | 354    | 43090      | 359    |
| 37328      | 234    | 38014      | 299    | 38941      | 226    | 39205      | 223    | 42171      | 354    | 43094      | 359    |
| 37330      | 234    | 38014      | 299    | 38942      | 225    | 39206      | 290    | 42172      | 354    | 43097      | 358    |
| 37331      | 234    | 38015      | 299    | 38943      | 226    | 39207      | 290    | 42173      | 354    | 43098      | 359    |
| 37332      | 234    | 38016      | 299    | 38944      | 224    | 39208      | 290    | 42174      | 354    | 43099      | 359    |
| 37340      | 236    | 38017      | 299    | 38945      | 224    | 39210      | 290    | 42175      | 353    | 43300      | 347    |
| 37341      | 236    | 38018      | 299    | 38946      | 224    | 39212      | 290    | 42176      | 353    | 43301      | 347    |
| 37342      | 236    | 38020      | 298    | 38947      | 224    | 39214      | 290    | 42177      | 353    | 44041      | 322    |
| 37343      | 236    | 38021      | 299    | 38948      | 224    | 39216      | 290    | 42178      | 353    | 44042      | 322    |

# LISTA PRODUSELOR



| Cod produs | pagina | Cod produs | pagina | Cod produs | pagina | Cod produs | pagina | Cod produs | pagina | Cod produs | pagina |
|------------|--------|------------|--------|------------|--------|------------|--------|------------|--------|------------|--------|
| 44043      | 322    | 45034      | 319    | 45099      | 310    | 45178      | 333    | 45268      | 335    | 45391      | 324    |
| 44050      | 322    | 45035      | 318    | 45100      | 334    | 45179      | 331    | 45269      | 335    | 45392      | 324    |
| 44053      | 319    | 45036      | 322    | 45101      | 334    | 45180      | 327    | 45270      | 39     | 45393      | 324    |
| 44950      | 131    | 45038      | 319    | 45102      | 334    | 45181      | 327    | 45271      | 39     | 45394      | 324    |
| 44950      | 315    | 45039      | 319    | 45104      | 334    | 45182      | 333    | 45280      | 334    | 45395      | 324    |
| 44955      | 319    | 45040      | 319    | 45105      | 334    | 45183      | 333    | 45283      | 334    | 45396      | 325    |
| 44960      | 323    | 45041      | 319    | 45106      | 334    | 45184      | 331    | 45285      | 334    | 45397      | 325    |
| 44965      | 338    | 45042      | 319    | 45107      | 334    | 45185      | 331    | 45286      | 334    | 45398      | 325    |
| 44970      | 313    | 45043      | 323    | 45108      | 334    | 45186      | 331    | 45287      | 334    | 45399      | 325    |
| 44971      | 313    | 45044      | 322    | 45110      | 326    | 45187      | 332    | 45289      | 329    | 45400      | 325    |
| 44972      | 310    | 45045      | 136    | 45111      | 327    | 45190      | 332    | 45290      | 329    | 45401      | 325    |
| 44980      | 310    | 45045      | 320    | 45112      | 327    | 45191      | 332    | 45291      | 329    | 45450      | 357    |
| 44980      | 310    | 45046      | 136    | 45113      | 327    | 45192      | 332    | 45292      | 329    | 45451      | 357    |
| 44980      | 311    | 45046      | 320    | 45114      | 327    | 45193      | 332    | 45293      | 329    | 45452      | 357    |
| 44981      | 310    | 45047      | 323    | 45115      | 327    | 45194      | 332    | 45294      | 328    | 45453      | 357    |
| 44981      | 310    | 45048      | 136    | 45116      | 326    | 45195      | 332    | 45295      | 328    | 45460      | 357    |
| 44981      | 311    | 45048      | 312    | 45117      | 326    | 45196      | 332    | 45296      | 328    | 45461      | 357    |
| 44981      | 311    | 45048      | 320    | 45118      | 326    | 45197      | 332    | 45297      | 328    | 45462      | 357    |
| 44982      | 310    | 45049      | 322    | 45120      | 327    | 45198      | 332    | 45298      | 328    | 45463      | 357    |
| 44982      | 310    | 45050      | 338    | 45122      | 327    | 45199      | 332    | 45299      | 328    | 45465      | 357    |
| 44982      | 311    | 45051      | 338    | 45123      | 326    | 45200      | 332    | 45300      | 333    | 45466      | 357    |
| 44983      | 310    | 45052      | 338    | 45124      | 326    | 45203      | 332    | 45301      | 333    | 45467      | 357    |
| 44983      | 310    | 45053      | 339    | 45125      | 326    | 45204      | 332    | 45320      | 339    | 45470      | 357    |
| 44983      | 311    | 45054      | 339    | 45126      | 326    | 45206      | 332    | 45321      | 339    | 45471      | 226    |
| 44984      | 311    | 45055      | 339    | 45130      | 329    | 45211      | 332    | 45323      | 337    | 45471      | 323    |
| 44984      | 312    | 45056      | 318    | 45131      | 329    | 45213      | 328    | 45323      | 348    | 45472      | 323    |
| 44984      | 312    | 45057      | 318    | 45132      | 329    | 45214      | 327    | 45325      | 337    | 45473      | 323    |
| 44985      | 311    | 45058      | 318    | 45133      | 329    | 45215      | 329    | 45326      | 337    | 45480      | 357    |
| 44985      | 312    | 45059      | 318    | 45134      | 330    | 45216      | 328    | 45326      | 337    | 45485      | 357    |
| 44991      | 311    | 45060      | 193    | 45135      | 329    | 45217      | 329    | 45327      | 337    | 45490      | 314    |
| 44992      | 311    | 45060      | 315    | 45136      | 329    | 45218      | 328    | 45328      | 337    | 45496      | 357    |
| 44995      | 314    | 45061      | 193    | 45137      | 329    | 45219      | 329    | 45329      | 337    | 45497      | 357    |
| 44996      | 312    | 45061      | 315    | 45138      | 328    | 45220      | 334    | 45330      | 337    | 45498      | 357    |
| 44997      | 312    | 45062      | 193    | 45139      | 328    | 45221      | 334    | 45330      | 350    | 45499      | 357    |
| 44998      | 312    | 45062      | 315    | 45140      | 328    | 45222      | 334    | 45331      | 337    | 45500      | 321    |
| 44999      | 313    | 45063      | 310    | 45141      | 328    | 45223      | 334    | 45331      | 350    | 45502      | 321    |
| 45000      | 314    | 45065      | 318    | 45142      | 328    | 45224      | 334    | 45341      | 333    | 45503      | 321    |
| 45001      | 314    | 45066      | 318    | 45143      | 328    | 45225      | 334    | 45342      | 333    | 45505      | 321    |
| 45002      | 314    | 45067      | 318    | 45144      | 329    | 45226      | 334    | 45343      | 333    | 45506      | 321    |
| 45003      | 314    | 45068      | 136    | 45145      | 329    | 45227      | 334    | 45344      | 333    | 45508      | 321    |
| 45005      | 314    | 45068      | 312    | 45146      | 330    | 45228      | 334    | 45345      | 333    | 45509      | 321    |
| 45006      | 314    | 45068      | 320    | 45147      | 331    | 45229      | 334    | 45346      | 333    | 45511      | 321    |
| 45007      | 314    | 45069      | 131    | 45150      | 331    | 45239      | 336    | 45347      | 333    | 45512      | 321    |
| 45008      | 314    | 45069      | 315    | 45151      | 331    | 45240      | 336    | 45348      | 333    | 45513      | 321    |
| 45009      | 314    | 45070      | 340    | 45152      | 330    | 45241      | 336    | 45349      | 333    | 45515      | 321    |
| 45010      | 312    | 45071      | 338    | 45153      | 330    | 45242      | 336    | 45350      | 333    | 45516      | 321    |
| 45011      | 313    | 45073      | 136    | 45154      | 330    | 45244      | 335    | 45351      | 333    | 45517      | 321    |
| 45012      | 313    | 45073      | 320    | 45155      | 330    | 45245      | 335    | 45352      | 333    | 45518      | 321    |
| 45014      | 312    | 45074      | 323    | 45156      | 331    | 45246      | 335    | 45353      | 333    | 45519      | 321    |
| 45015      | 313    | 45079      | 319    | 45158      | 330    | 45247      | 335    | 45354      | 333    | 45520      | 321    |
| 45016      | 313    | 45080      | 319    | 45159      | 331    | 45248      | 335    | 45370      | 136    | 45521      | 321    |
| 45017      | 311    | 45081      | 131    | 45160      | 331    | 45249      | 335    | 45370      | 320    | 45522      | 321    |
| 45018      | 312    | 45081      | 315    | 45161      | 331    | 45250      | 335    | 45372      | 325    | 45523      | 321    |
| 45019      | 312    | 45082      | 131    | 45162      | 330    | 45251      | 335    | 45372      | 333    | 45524      | 321    |
| 45020      | 310    | 45082      | 315    | 45163      | 330    | 45253      | 335    | 45373      | 325    | 45525      | 321    |
| 45021      | 312    | 45083      | 131    | 45164      | 331    | 45254      | 335    | 45373      | 333    | 45526      | 321    |
| 45023      | 310    | 45083      | 315    | 45167      | 330    | 45256      | 335    | 45374      | 325    | 45527      | 321    |
| 45025      | 313    | 45084      | 131    | 45168      | 331    | 45257      | 335    | 45374      | 333    | 45528      | 321    |
| 45026      | 312    | 45084      | 315    | 45169      | 331    | 45260      | 335    | 45375      | 325    | 45529      | 321    |
| 45027      | 313    | 45085      | 319    | 45170      | 336    | 45261      | 335    | 45375      | 333    | 45530      | 321    |
| 45029      | 313    | 45086      | 323    | 45171      | 336    | 45262      | 335    | 45376      | 325    | 45531      | 321    |
| 45030      | 193    | 45088      | 311    | 45172      | 336    | 45262      | 335    | 45376      | 333    | 45532      | 321    |
| 45030      | 315    | 45089      | 311    | 45172      | 336    | 45263      | 335    | 45377      | 325    | 45533      | 321    |
| 45031      | 193    | 45093      | 323    | 45173      | 336    | 45263      | 335    | 45377      | 333    | 45534      | 321    |
| 45031      | 315    | 45094      | 311    | 45173      | 336    | 45265      | 335    | 45385      | 324    | 45535      | 322    |
| 45032      | 193    | 45095      | 310    | 45174      | 333    | 45266      | 335    | 45386      | 324    | 45540      | 321    |
| 45032      | 315    | 45096      | 310    | 45175      | 332    | 45267      | 335    | 45388      | 324    | 45541      | 321    |
| 45033      | 193    | 45097      | 311    | 45176      | 333    | 45267      | 335    | 45389      | 324    | 45542      | 321    |
| 45033      | 315    | 45098      | 310    | 45177      | 333    | 45268      | 335    | 45390      | 324    | 45543      | 321    |

| Cod produs | pagina | Cod produs | pagina | Cod produs | pagina | Cod produs | pagina | Cod produs | pagina | Cod produs | pagina |
|------------|--------|------------|--------|------------|--------|------------|--------|------------|--------|------------|--------|
| 45550      | 321    | 45660      | 322    | 48094      | 49     | 50544      | 233    | 51244      | 227    | 52055      | 307    |
| 45551      | 321    | 45661      | 322    | 48095      | 49     | 50549      | 232    | 51245      | 227    | 52060      | 307    |
| 45552      | 321    | 45662      | 322    | 48096      | 49     | 50550      | 230    | 51246      | 227    | 52065      | 307    |
| 45553      | 321    | 45663      | 322    | 48097      | 49     | 50551      | 230    | 51247      | 227    | 52070      | 300    |
| 45555      | 322    | 45664      | 322    | 48410      | 306    | 50553      | 230    | 51258      | 227    | 52071      | 300    |
| 45556      | 321    | 45670      | 322    | 48411      | 306    | 50554      | 230    | 51259      | 227    | 52075      | 300    |
| 45557      | 321    | 45671      | 322    | 48415      | 306    | 50555      | 233    | 51260      | 227    | 52076      | 300    |
| 45558      | 321    | 45672      | 322    | 48420      | 306    | 50556      | 230    | 51261      | 227    | 52077      | 300    |
| 45559      | 321    | 45673      | 322    | 48452      | 307    | 50557      | 232    | 51262      | 227    | 52078      | 300    |
| 45560      | 322    | 48001      | 48     | 48453      | 307    | 50558      | 232    | 51264      | 227    | 52101      | 349    |
| 45562      | 321    | 48002      | 48     | 48454      | 307    | 50559      | 230    | 51271      | 227    | 52102      | 349    |
| 45563      | 321    | 48004      | 47     | 48455      | 307    | 50560      | 230    | 51272      | 227    | 52103      | 349    |
| 45564      | 321    | 48005      | 47     | 48456      | 307    | 50562      | 230    | 51273      | 227    | 52104      | 349    |
| 45565      | 321    | 48006      | 47     | 48457      | 307    | 50563      | 230    | 51274      | 227    | 52105      | 349    |
| 45570      | 354    | 48007      | 47     | 48719      | 273    | 50564      | 230    | 51275      | 227    | 52108      | 348    |
| 45571      | 354    | 48008      | 49     | 48729      | 269    | 50570      | 230    | 51276      | 227    | 52109      | 349    |
| 45572      | 354    | 48009      | 49     | 48730      | 269    | 50571      | 230    | 51278      | 227    | 52113      | 349    |
| 45573      | 354    | 48010      | 48     | 48731      | 269    | 50585      | 233    | 51280      | 227    | 52114      | 349    |
| 45580      | 354    | 48011      | 48     | 50030      | 355    | 50585      | 303    | 51281      | 227    | 52115      | 349    |
| 45600      | 334    | 48013      | 15     | 50031      | 355    | 50586      | 233    | 51282      | 227    | 52116      | 349    |
| 45601      | 334    | 48013      | 48     | 50032      | 355    | 50586      | 303    | 51283      | 227    | 52119      | 348    |
| 45602      | 334    | 48015      | 47     | 50033      | 355    | 50587      | 233    | 51284      | 227    | 52126      | 350    |
| 45603      | 334    | 48020      | 46     | 50035      | 228    | 50587      | 303    | 51286      | 227    | 52130      | 280    |
| 45604      | 334    | 48021      | 46     | 50035      | 355    | 50588      | 233    | 51287      | 227    | 52135      | 348    |
| 45605      | 334    | 48022      | 46     | 50036      | 228    | 50588      | 303    | 51288      | 227    | 52160      | 349    |
| 45606      | 334    | 48030      | 47     | 50036      | 355    | 51100      | 228    | 51300      | 227    | 52161      | 349    |
| 45607      | 334    | 48031      | 48     | 50037      | 355    | 51102      | 228    | 51301      | 227    | 52162      | 349    |
| 45608      | 334    | 48032      | 48     | 50038      | 355    | 51103      | 228    | 51302      | 227    | 52163      | 349    |
| 45609      | 334    | 48033      | 48     | 50040      | 355    | 51104      | 228    | 51303      | 227    | 52164      | 349    |
| 45610      | 334    | 48034      | 48     | 50041      | 355    | 51105      | 228    | 51304      | 227    | 52168      | 348    |
| 45611      | 334    | 48036      | 47     | 50042      | 355    | 51106      | 228    | 51305      | 227    | 52173      | 348    |
| 45612      | 334    | 48037      | 47     | 50050      | 222    | 51107      | 228    | 51306      | 227    | 52175      | 348    |
| 45613      | 334    | 48040      | 48     | 50050      | 222    | 51108      | 228    | 51307      | 227    | 52176      | 348    |
| 45614      | 334    | 48041      | 48     | 50051      | 222    | 51109      | 228    | 51308      | 227    | 52185      | 349    |
| 45615      | 334    | 48042      | 48     | 50052      | 222    | 51110      | 228    | 51320      | 227    | 52186      | 349    |
| 45616      | 334    | 48043      | 48     | 50052      | 222    | 51111      | 228    | 51321      | 227    | 52187      | 349    |
| 45617      | 334    | 48046      | 46     | 50100      | 227    | 51120      | 228    | 51322      | 227    | 52188      | 349    |
| 45618      | 334    | 48046      | 49     | 50101      | 227    | 51121      | 228    | 51323      | 227    | 52189      | 349    |
| 45619      | 334    | 48047      | 46     | 50102      | 227    | 51122      | 228    | 51324      | 227    | 52190      | 349    |
| 45620      | 334    | 48047      | 49     | 50103      | 227    | 51123      | 228    | 51325      | 227    | 52191      | 349    |
| 45621      | 334    | 48050      | 49     | 50104      | 227    | 51124      | 228    | 51327      | 227    | 52192      | 349    |
| 45622      | 334    | 48051      | 49     | 50106      | 227    | 51125      | 228    | 51341      | 227    | 52193      | 349    |
| 45623      | 334    | 48054      | 49     | 50108      | 227    | 51126      | 228    | 51402      | 228    | 52194      | 349    |
| 45624      | 334    | 48055      | 49     | 50500      | 233    | 51127      | 228    | 51403      | 228    | 52195      | 349    |
| 45625      | 334    | 48056      | 49     | 50503      | 233    | 51130      | 228    | 51404      | 228    | 52196      | 349    |
| 45626      | 334    | 48057      | 49     | 50510      | 230    | 51131      | 228    | 51405      | 228    | 52197      | 348    |
| 45627      | 334    | 48060      | 49     | 50511      | 230    | 51132      | 228    | 51406      | 228    | 52198      | 348    |
| 45628      | 334    | 48061      | 49     | 50512      | 230    | 51196      | 228    | 51407      | 228    | 52202      | 300    |
| 45629      | 334    | 48062      | 49     | 50513      | 230    | 51197      | 228    | 51408      | 228    | 52203      | 300    |
| 45630      | 334    | 48063      | 49     | 50514      | 230    | 51198      | 228    | 51410      | 228    | 52204      | 300    |
| 45631      | 334    | 48064      | 49     | 50518      | 232    | 51199      | 228    | 51412      | 228    | 52205      | 300    |
| 45632      | 334    | 48065      | 49     | 50519      | 232    | 51204      | 227    | 51413      | 228    | 52206      | 300    |
| 45633      | 334    | 48066      | 49     | 50520      | 232    | 51205      | 227    | 51414      | 228    | 52207      | 300    |
| 45634      | 334    | 48067      | 49     | 50522      | 232    | 51206      | 227    | 51415      | 228    | 52208      | 300    |
| 45635      | 334    | 48068      | 49     | 50524      | 232    | 51207      | 227    | 51416      | 228    | 52212      | 300    |
| 45636      | 334    | 48070      | 49     | 50525      | 232    | 51208      | 227    | 51417      | 228    | 52213      | 300    |
| 45637      | 334    | 48071      | 49     | 50526      | 232    | 51209      | 227    | 51418      | 228    | 52214      | 300    |
| 45638      | 334    | 48072      | 49     | 50527      | 233    | 51210      | 227    | 51420      | 228    | 52215      | 300    |
| 45639      | 334    | 48075      | 49     | 50529      | 232    | 51211      | 227    | 51430      | 228    | 52216      | 300    |
| 45650      | 322    | 48076      | 49     | 50531      | 233    | 51212      | 227    | 51431      | 228    | 52217      | 300    |
| 45651      | 322    | 48077      | 49     | 50532      | 233    | 51220      | 227    | 51432      | 228    | 52218      | 300    |
| 45652      | 322    | 48080      | 49     | 50533      | 232    | 51221      | 227    | 51433      | 228    | 52220      | 300    |
| 45653      | 322    | 48081      | 49     | 50535      | 232    | 51222      | 227    | 51435      | 228    | 52283      | 300    |
| 45654      | 322    | 48085      | 49     | 50536      | 232    | 51225      | 227    | 51436      | 228    | 52284      | 300    |
| 45655      | 322    | 48086      | 49     | 50537      | 232    | 51226      | 227    | 51450      | 228    | 52285      | 300    |
| 45656      | 322    | 48087      | 49     | 50539      | 232    | 51227      | 227    | 52011      | 249    | 52286      | 300    |
| 45657      | 322    | 48090      | 49     | 50540      | 233    | 51241      | 227    | 52011      | 303    | 52288      | 300    |
| 45658      | 322    | 48091      | 49     | 50541      | 233    | 51242      | 227    | 52030      | 252    | 52305      | 301    |
| 45659      | 322    | 48093      | 49     | 50542      | 233    | 51243      | 227    | 52050      | 307    | 52306      | 301    |

# LISTA PRODUSELOR



| Cod produs | pagina | Cod produs | pagina | Cod produs | pagina | Cod produs | pagina | Cod produs | pagina | Cod produs | pagina |
|------------|--------|------------|--------|------------|--------|------------|--------|------------|--------|------------|--------|
| 52328      | 301    | 55356      | 229    | 61003      | 344    | 61098      | 345    | 61236      | 217    | 70025      | 44     |
| 52331      | 301    | 55357      | 229    | 61004      | 344    | 61098      | 351    | 61240      | 197    | 70026      | 44     |
| 52334      | 301    | 55358      | 229    | 61005      | 341    | 61111      | 346    | 61250      | 351    | 70030      | 44     |
| 52391      | 301    | 55359      | 229    | 61005      | 351    | 61112      | 346    | 61251      | 319    | 70031      | 44     |
| 52421      | 301    | 55360      | 229    | 61006      | 341    | 61114      | 346    | 61251      | 351    | 70032      | 44     |
| 52424      | 301    | 55361      | 229    | 61006      | 351    | 61120      | 346    | 61252      | 351    | 70033      | 44     |
| 52428      | 301    | 55362      | 229    | 61007      | 341    | 61121      | 346    | 61253      | 351    | 70035      | 44     |
| 52456      | 301    | 55400      | 356    | 61008      | 341    | 61130      | 338    | 61254      | 351    | 70036      | 44     |
| 52471      | 301    | 55401      | 356    | 61009      | 345    | 61131      | 338    | 61255      | 351    | 70037      | 44     |
| 52600      | 302    | 55402      | 356    | 61010      | 341    | 61132      | 339    | 61256      | 351    | 70040      | 43     |
| 52601      | 302    | 55403      | 356    | 61012      | 345    | 61133      | 339    | 61290      | 346    | 70060      | 44     |
| 52602      | 302    | 55404      | 356    | 61013      | 344    | 61134      | 339    | 61291      | 346    | 70061      | 44     |
| 52605      | 302    | 55405      | 356    | 61014      | 345    | 61135      | 339    | 61292      | 346    | 70062      | 44     |
| 52610      | 302    | 55406      | 356    | 61015      | 341    | 61141      | 339    | 61293      | 346    | 70063      | 44     |
| 52611      | 248    | 55420      | 356    | 61018      | 345    | 61142      | 340    | 61294      | 318    | 70064      | 43     |
| 52612      | 248    | 55421      | 356    | 61019      | 344    | 61143      | 340    | 61295      | 318    | 70065      | 44     |
| 52620      | 302    | 55422      | 356    | 61020      | 342    | 61144      | 340    | 61296      | 318    | 70066      | 43     |
| 52625      | 302    | 55423      | 356    | 61021      | 342    | 61145      | 340    | 61297      | 318    | 70070      | 44     |
| 52630      | 302    | 55424      | 356    | 61022      | 343    | 61146      | 340    | 61299      | 356    | 70075      | 44     |
| 52635      | 302    | 55425      | 356    | 61024      | 343    | 61150      | 338    | 61300      | 356    | 70090      | 45     |
| 52640      | 302    | 55429      | 356    | 61025      | 342    | 61155      | 341    | 61301      | 356    | 70091      | 45     |
| 52645      | 302    | 55430      | 356    | 61026      | 342    | 61156      | 341    | 61302      | 356    | 70092      | 45     |
| 52652      | 302    | 55431      | 356    | 61027      | 343    | 61157      | 341    | 61320      | 197    | 70093      | 45     |
| 52656      | 302    | 55432      | 356    | 61028      | 345    | 61158      | 341    | 61321      | 197    | 70094      | 45     |
| 52662      | 302    | 55433      | 356    | 61029      | 341    | 61161      | 344    | 61322      | 197    | 70095      | 45     |
| 52666      | 302    | 55436      | 356    | 61030      | 340    | 61162      | 344    | 61323      | 197    | 70096      | 45     |
| 52671      | 302    | 55437      | 356    | 61031      | 340    | 61163      | 344    | 61324      | 197    | 70098      | 210    |
| 52694      | 302    | 55450      | 356    | 61032      | 340    | 61164      | 345    | 61325      | 197    | 81011      | 361    |
| 52695      | 302    | 55452      | 356    | 61033      | 340    | 61165      | 345    | 61326      | 197    | 81012      | 361    |
| 54008      | 303    | 55453      | 356    | 61034      | 340    | 61166      | 345    | 61327      | 197    | 81013      | 361    |
| 55040      | 229    | 55454      | 356    | 61035      | 346    | 61169      | 251    | 61328      | 197    | 81014      | 361    |
| 55050      | 229    | 55455      | 356    | 61036      | 346    | 61171      | 350    | 61329      | 197    | 81015      | 361    |
| 55051      | 229    | 55456      | 356    | 61038      | 346    | 61172      | 348    | 61330      | 197    | 81016      | 361    |
| 55060      | 229    | 55457      | 356    | 61040      | 346    | 61172      | 350    | 61331      | 197    | 81022      | 361    |
| 55080      | 229    | 55460      | 356    | 61042      | 346    | 61173      | 350    | 61340      | 317    | 81023      | 361    |
| 55100      | 229    | 55461      | 356    | 61044      | 345    | 61174      | 350    | 61341      | 317    | 81024      | 361    |
| 55120      | 229    | 55462      | 356    | 61045      | 340    | 61175      | 350    | 61342      | 317    | 81025      | 361    |
| 55140      | 229    | 55465      | 356    | 61046      | 340    | 61176      | 350    | 61343      | 317    | 81035      | 361    |
| 55160      | 229    | 55640      | 229    | 61047      | 340    | 61177      | 350    | 61344      | 317    | 81036      | 361    |
| 55180      | 229    | 55642      | 229    | 61048      | 340    | 61183      | 351    | 61345      | 317    | 81053      | 364    |
| 55181      | 229    | 55645      | 229    | 61050      | 342    | 61184      | 351    | 61346      | 317    | 81054      | 364    |
| 55200      | 229    | 55650      | 229    | 61050      | 351    | 61189      | 351    | 65062      | 307    | 81057      | 364    |
| 55201      | 229    | 60001      | 347    | 61051      | 342    | 61190      | 351    | 65063      | 307    | 81070      | 364    |
| 55220      | 229    | 60006      | 347    | 61051      | 351    | 61192      | 350    | 65064      | 307    | 81071      | 364    |
| 55221      | 229    | 60008      | 347    | 61052      | 343    | 61193      | 350    | 65065      | 307    | 81077      | 364    |
| 55240      | 229    | 60012      | 347    | 61052      | 351    | 61194      | 350    | 69900      | 294    | 81100      | 364    |
| 55300      | 229    | 60018      | 347    | 61053      | 343    | 61195      | 351    | 69901      | 294    | 81101      | 364    |
| 55315      | 229    | 60019      | 347    | 61054      | 343    | 61200      | 350    | 69902      | 294    | 81102      | 364    |
| 55316      | 229    | 60020      | 347    | 61056      | 342    | 61201      | 347    | 69903      | 294    | 81103      | 364    |
| 55317      | 229    | 60022      | 347    | 61057      | 342    | 61201      | 350    | 69904      | 295    | 81104      | 364    |
| 55318      | 229    | 60100      | 251    | 61058      | 343    | 61202      | 350    | 69905      | 294    | 81105      | 364    |
| 55319      | 229    | 60115      | 273    | 61059      | 343    | 61203      | 345    | 69906      | 294    | 81106      | 364    |
| 55331      | 229    | 60116      | 273    | 61060      | 340    | 61204      | 351    | 69907      | 295    | 81150      | 362    |
| 55332      | 229    | 60117      | 273    | 61061      | 340    | 61205      | 351    | 69908      | 295    | 81151      | 362    |
| 55333      | 229    | 60118      | 273    | 61062      | 340    | 61207      | 351    | 69909      | 295    | 81152      | 362    |
| 55334      | 229    | 60121      | 273    | 61063      | 340    | 61208      | 350    | 69910      | 295    | 81155      | 362    |
| 55335      | 229    | 60123      | 273    | 61067      | 346    | 61209      | 345    | 69911      | 295    | 81160      | 362    |
| 55336      | 229    | 60125      | 272    | 61068      | 346    | 61215      | 351    | 69912      | 295    | 81165      | 362    |
| 55337      | 229    | 60130      | 272    | 61069      | 346    | 61218      | 251    | 69914      | 294    | 81170      | 362    |
| 55339      | 229    | 60132      | 272    | 61070      | 346    | 61219      | 351    | 69917      | 295    | 81175      | 362    |
| 55340      | 229    | 60155      | 272    | 61077      | 351    | 61221      | 318    | 69918      | 294    | 81178      | 362    |
| 55341      | 229    | 60157      | 272    | 61079      | 351    | 61221      | 318    | 69919      | 294    | 81180      | 362    |
| 55342      | 229    | 60201      | 347    | 61079      | 351    | 61221      | 318    | 69920      | 295    | 81185      | 362    |
| 55350      | 229    | 60206      | 347    | 61085      | 319    | 61221      | 318    | 69923      | 295    | 81186      | 362    |
| 55351      | 229    | 60208      | 347    | 61088      | 342    | 61222      | 345    | 69928      | 295    | 81188      | 362    |
| 55352      | 229    | 60212      | 347    | 61089      | 342    | 61223      | 344    | 69930      | 296    | 81189      | 362    |
| 55353      | 229    | 61000      | 342    | 61090      | 343    | 61224      | 346    | 69931      | 296    | 81190      | 362    |
| 55354      | 229    | 61001      | 342    | 61097      | 344    | 61224      | 346    | 70020      | 44     | 81191      | 362    |
| 55355      | 229    | 61002      | 343    | 61097      | 351    | 61230      | 351    | 70021      | 44     | 81195      | 361    |

| Cod produs | pagina | Cod produs | pagina | Cod produs | pagina | Cod produs | pagina | Cod produs | pagina | Cod produs | pagina |
|------------|--------|------------|--------|------------|--------|------------|--------|------------|--------|------------|--------|
| 81196      | 361    | 81267      | 363    | 81337      | 363    | 81408      | 363    | 82103      | 307    |            |        |
| 81197      | 361    | 81268      | 363    | 81338      | 363    | 81409      | 363    | 82104      | 307    |            |        |
| 81200      | 363    | 81269      | 363    | 81339      | 363    | 81410      | 363    | 89775      | 51     |            |        |
| 81201      | 363    | 81270      | 363    | 81340      | 363    | 81411      | 363    | 89970      | 51     |            |        |
| 81202      | 363    | 81271      | 363    | 81341      | 363    | 81412      | 363    | 89973      | 51     |            |        |
| 81203      | 363    | 81272      | 363    | 81342      | 363    | 81413      | 363    | 89975      | 51     |            |        |
| 81204      | 363    | 81273      | 363    | 81343      | 363    | 81414      | 363    | 89980      | 51     |            |        |
| 81205      | 363    | 81274      | 363    | 81344      | 363    | 81415      | 363    | 89985      | 51     |            |        |
| 81206      | 363    | 81275      | 363    | 81345      | 363    | 81416      | 363    | 89987      | 51     |            |        |
| 81207      | 363    | 81276      | 363    | 81346      | 363    | 81417      | 363    | 89988      | 51     |            |        |
| 81208      | 363    | 81277      | 363    | 81347      | 363    | 81418      | 363    | 89989      | 51     |            |        |
| 81209      | 363    | 81278      | 363    | 81348      | 363    | 81419      | 363    | 89990      | 51     |            |        |
| 81210      | 363    | 81279      | 363    | 81349      | 363    | 81420      | 363    | 90070      | 278    |            |        |
| 81211      | 363    | 81280      | 363    | 81350      | 363    | 81421      | 363    | 90071      | 278    |            |        |
| 81212      | 363    | 81281      | 363    | 81351      | 363    | 81422      | 363    | 90072      | 278    |            |        |
| 81213      | 363    | 81282      | 363    | 81352      | 363    | 81423      | 363    | 90191      | 56     |            |        |
| 81214      | 363    | 81284      | 363    | 81353      | 363    | 81424      | 363    | 90192      | 57     |            |        |
| 81215      | 363    | 81285      | 363    | 81354      | 363    | 81425      | 363    | 18610A     | 150    |            |        |
| 81216      | 363    | 81286      | 363    | 81355      | 363    | 81426      | 363    | 18611A     | 150    |            |        |
| 81217      | 363    | 81287      | 363    | 81356      | 363    | 81427      | 363    | 18612A     | 150    |            |        |
| 81218      | 363    | 81288      | 363    | 81357      | 363    | 81428      | 363    | 18613A     | 150    |            |        |
| 81219      | 363    | 81289      | 363    | 81358      | 363    | 81429      | 363    | 18614A     | 150    |            |        |
| 81220      | 363    | 81290      | 363    | 81359      | 363    | 81430      | 363    | 18615A     | 150    |            |        |
| 81221      | 363    | 81291      | 363    | 81360      | 363    | 81431      | 363    | 18632A     | 147    |            |        |
| 81222      | 363    | 81292      | 363    | 81361      | 363    | 81432      | 363    | 18633A     | 147    |            |        |
| 81223      | 363    | 81293      | 363    | 81362      | 363    | 81433      | 363    | 18636A     | 147    |            |        |
| 81224      | 363    | 81294      | 363    | 81363      | 363    | 81434      | 363    | 18637A     | 147    |            |        |
| 81225      | 363    | 81295      | 363    | 81364      | 363    | 81435      | 363    | 18638A     | 147    |            |        |
| 81226      | 363    | 81296      | 363    | 81365      | 363    | 81436      | 363    | 18827A     | 147    |            |        |
| 81227      | 363    | 81297      | 363    | 81366      | 363    | 81437      | 363    | 18828A     | 147    |            |        |
| 81228      | 363    | 81298      | 363    | 81367      | 363    | 81438      | 363    | 18830A     | 147    |            |        |
| 81229      | 363    | 81299      | 363    | 81370      | 363    | 81439      | 363    | 18831A     | 147    |            |        |
| 81230      | 363    | 81300      | 363    | 81371      | 363    | 81440      | 363    | 81011A     | 361    |            |        |
| 81231      | 363    | 81301      | 363    | 81372      | 363    | 81441      | 363    | 81011F     | 361    |            |        |
| 81232      | 363    | 81302      | 363    | 81373      | 363    | 81442      | 363    | 81011G     | 361    |            |        |
| 81233      | 363    | 81303      | 363    | 81374      | 363    | 81443      | 363    | 81011H     | 361    |            |        |
| 81234      | 363    | 81304      | 363    | 81375      | 363    | 81444      | 363    | 81011R     | 361    |            |        |
| 81235      | 363    | 81305      | 363    | 81376      | 363    | 81445      | 363    | M90203     | 365    |            |        |
| 81236      | 363    | 81306      | 363    | 81377      | 363    | 81447      | 363    | M90204     | 365    |            |        |
| 81237      | 363    | 81307      | 363    | 81378      | 363    | 81448      | 363    | M90205     | 365    |            |        |
| 81238      | 363    | 81308      | 363    | 81379      | 363    | 81449      | 363    | M90206     | 365    |            |        |
| 81239      | 363    | 81309      | 363    | 81380      | 363    | 81450      | 363    | M90207     | 365    |            |        |
| 81240      | 363    | 81310      | 363    | 81381      | 363    | 81451      | 363    | M90210     | 365    |            |        |
| 81241      | 363    | 81311      | 363    | 81382      | 363    | 81452      | 363    | M90220     | 365    |            |        |
| 81242      | 363    | 81312      | 363    | 81383      | 363    | 81453      | 363    | M90221     | 365    |            |        |
| 81243      | 363    | 81313      | 363    | 81384      | 363    | 81454      | 363    | M90222     | 365    |            |        |
| 81244      | 363    | 81314      | 363    | 81385      | 363    | 81455      | 363    | M90400     | 365    |            |        |
| 81245      | 363    | 81315      | 363    | 81386      | 363    | 81456      | 363    | M90403     | 365    |            |        |
| 81246      | 363    | 81316      | 363    | 81387      | 363    | 81457      | 363    | M90519     | 365    |            |        |
| 81247      | 363    | 81317      | 363    | 81388      | 363    | 81458      | 363    |            |        |            |        |
| 81248      | 363    | 81318      | 363    | 81389      | 363    | 81459      | 363    |            |        |            |        |
| 81249      | 363    | 81319      | 363    | 81390      | 363    | 81460      | 363    |            |        |            |        |
| 81250      | 363    | 81320      | 363    | 81391      | 363    | 81461      | 363    |            |        |            |        |
| 81251      | 363    | 81321      | 363    | 81392      | 363    | 81462      | 363    |            |        |            |        |
| 81252      | 363    | 81322      | 363    | 81393      | 363    | 81463      | 363    |            |        |            |        |
| 81253      | 363    | 81323      | 363    | 81394      | 363    | 81466      | 363    |            |        |            |        |
| 81254      | 363    | 81324      | 363    | 81395      | 363    | 81467      | 363    |            |        |            |        |
| 81255      | 363    | 81325      | 363    | 81396      | 363    | 81468      | 363    |            |        |            |        |
| 81256      | 363    | 81326      | 363    | 81397      | 363    | 81469      | 363    |            |        |            |        |
| 81257      | 363    | 81327      | 363    | 81398      | 363    | 81470      | 363    |            |        |            |        |
| 81258      | 363    | 81328      | 363    | 81399      | 363    | 81471      | 363    |            |        |            |        |
| 81259      | 363    | 81329      | 363    | 81400      | 363    | 81472      | 363    |            |        |            |        |
| 81260      | 363    | 81330      | 363    | 81401      | 363    | 81473      | 363    |            |        |            |        |
| 81261      | 363    | 81331      | 363    | 81402      | 363    | 81486      | 363    |            |        |            |        |
| 81262      | 363    | 81332      | 363    | 81403      | 363    | 81600      | 364    |            |        |            |        |
| 81263      | 363    | 81333      | 363    | 81404      | 363    | 81603      | 364    |            |        |            |        |
| 81264      | 363    | 81334      | 363    | 81405      | 363    | 82100      | 307    |            |        |            |        |
| 81265      | 363    | 81335      | 363    | 81406      | 363    | 82101      | 307    |            |        |            |        |
| 81266      | 363    | 81336      | 363    | 81407      | 363    | 82102      | 307    |            |        |            |        |

# LISTĂ PICTOGRAME FOLOSITE

## · DESCRIEREA PRODUSULUI



· realizate în Republica Cehă

· realizate în Uniunea Europeană

## SPECIFICAȚIILE APLICAȚIEI ·

- lemn ·
- ceramica ·
- plastic ·
- aluminiu · **ALU**
- cupru · **Cu**
- piatra ·
- sticlă ·
- zidarie ·
- hârtie ·
- oțel ·
- compozit ·
- gresie ·
- oțel inoxidabil · **INOX**
- ghips ·
- lemn cu șurub, cuie ·
- gips-carton ·
- pentru foraj în materiale cu rezistență la tracțiune până la... **900 MPa**

- S2** · oțel S2
- HSS** · oțel rapid
- Cr-Mo** · oțel crom-molibden
- CrV** · oțel crom-vanadiu
- INOX** · oel inoxidabil
- NYLON** · nylon coada
- TEFLON** · suprafață de teflon
- Zn** · suprafață acoperită cu zinc
- TiN** · suprafață acoperită cu nitrură de titan
- HRC 58-61** · HRC - duritatea materialului
- 40% PES** · conținut procentual de material - 40% poliester
- PES** · 100% poliester
- diamant fi nisaj de suprafaa
- produsul sau o parte a acestuia este magnetic

- SDS+** **SDS MAX** **M14** · metoda de atașare
- 72T** **36T** · număr de dini în mecanism cu clichet
- 1/2"** **3/4"** **1/4"** · cu clichet
- 27 dB** · Informații despre protecția sunetului
- DIN 3113** **IP 54** · standard
- 32x** · numărul de bucai în pachet
- II. class** **III. class** · clasa de precizie
- potrivit pentru vreme rece
- ERGO HANDLE** · mâner ergonomic
- HOBBY** · pentru uz hobby
- 2x AAA** · tipul și numărul de baterii necesare
- UV STABLE** · Stabila la UV
- RUBBER ENDS** · capace de cauciuc rezistent la impact



## · INFORMATIILE DESPRE AMBALARE

- împachetat într-o cutie
- euroslot
- MOQ 12** · Cantitatea minimă pentru comanda
- 5** · numărul de piese din pachet

## LISTA PICTOGRAME FOLOSITE - FESTA AQUATIC, ROSA ·

modele de pulverizare reglabile ·

presiune minimă și maximă ·



debitul maxim de apă ·



zona irigată ·



dimensiunea firului adaptorului ·



diametrul furtunului ·



20

25

26

**FESTA**

SCULE X PROFESIONALE



festatools



#festatools



festatools



[www.festa.tools](http://www.festa.tools)

HORIZONT.

**FESTA**  
POWER X TOOLS

**FESTA**  
AQUATIC

ROSA KOMELON.

KDS

Stahlberg

SUPER PRO

Lescha

