



FESTA

PROFESJONALNE  NARZĘDZIA



20
25
—
26

FESTA
POWER X TOOLS

Kompleksowa grupa produktów akumulatorowych wykorzystująca wysokiej jakości komponenty, najnowsze technologie i aktualne trendy w narzędziach akumulatorowych

FESTA

Marka wysokiej jakości narzędzi ręcznych dla budownictwa, warsztatu i ogrodu

FESTA
INDUSTRY

Premiowa seria wybranych narzędzi i narzędzi ręcznych najwyższej jakości, zaprojektowanych do trudnych warunków pracy, gdzie wydajność jest priorytetem.

FESTA
AQUATIC

Profesjonalna seria systemów nawadniających o nowoczesnym wzornictwie, kompatybilna z serią produktów Rosa

HORIZONT
MASTER

Marka najlepszych poziomnic

HORIZONT

Marka wysokiej jakości poziomnic i łat pomiarowych

ROSA

Kwalitního zavlažovací systémy a zahradní nářadí

KDS[®]

Japońskie noże o długiej tradycji

KOMELON[®]

Profesjonalne narzędzia pomiarowe



Profesjonalne narzędzia pomiarowe



Producent wysokiej jakości nożyc ogrodowych

Lescha

Profesjonalne betoniarki budowlane

Stahlberg

Profesjonalne narzędzia do wkrecania



Marka profesjonalnych pił

ELEKTRONARZĘDZIA

2 - 53

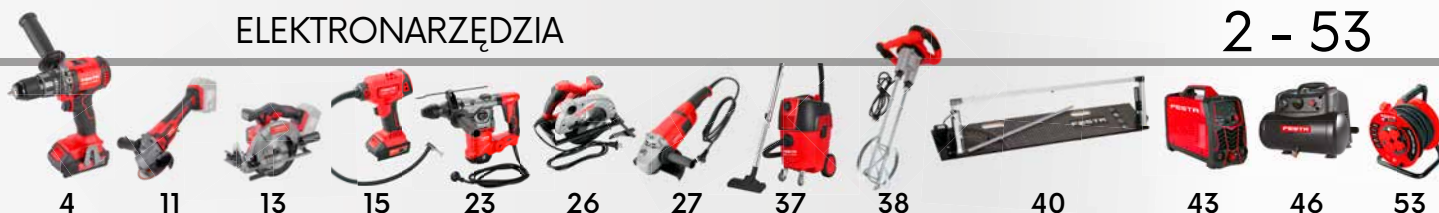

CIĘCIE I SZLIFOWANIE

54 - 93



NARZĘDZIA WARSZTATOWE

94 - 205



WARSZTAT

206 - 241



NARZĘDZIA BUDOWLANE

242 - 307

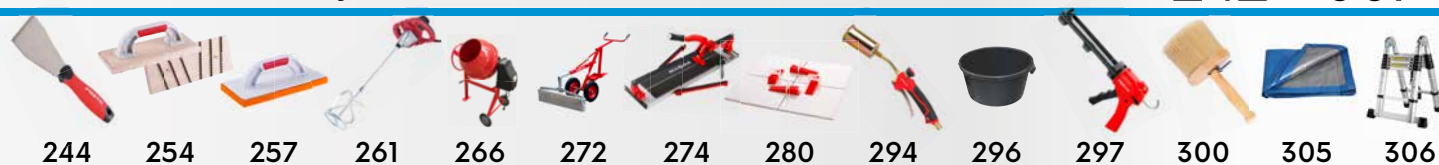

NARZĘDZIA OGRODNICZE

308 - 359



FESTA

360 - 365



LISTA RZECZY

366 - 380



WIERTARKA

4



WIERTARKA UDAROWA

9



GWOZDZIARKA I ZSZYWCZ

10



SZLIFIERKA KATOWA

11



SZLIFIERKA OSCYLACYJNA

12



PIŁA TARCZOWA

13



KOMPRESOR

15



PRZYSSAWKA WIBRACYJNA

16



PISTOLET DO USZCZELNIANIA

17



SWIATŁO LED

17



RADIO DAB+ / FM / BT

18



WIERTARKA UDAROWA

23



PIŁA TARCZOWA

26



SZLIFIERKA KATOWA

27



SZLIFIERKA DO PŁYT KARTONOWO-GISOWYCH

36



ODKURZACZE

37

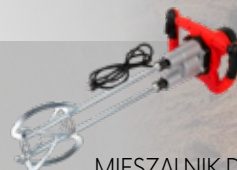

MIESZALNIK DO MIESZANEK BUDOWLANYCH

38



MYJKI WYSOKOCIŚNIENIOWE

39



PRZECINARKI DO STYROPIANU

40



FALOWNIK SPAWALNICZY

43



SPAWACZE POLIFUZYJNE

45



KOMPRESORY I AKCESORIA

46



PISTOLETY NA GORĄCE POWIETRZE

50



GRZEJNIKI

52



KABLE PRZEDŁUŻAJĄCE

53



ELEKTRONARZĘDZIA

2 - 53



FESTA
POWER X TOOLS

BRUSHLESS **SHARE** **20V** *Li-ion*
technology

prędkość
0-550 min⁻¹
0-2000 min⁻¹

masa
z baterią 2,0 Ah **1,8 kg**
z baterią 4,0 Ah **2,1 kg**

moment obrotowy
80 Nm

średnica
2 - 13 mm



Zestaw zawiera:
- wiertarka udarowa
- 2.0 Ah bateria
- 4.0 Ah bateria
- 2.4 A ładowarka
- dodatkowy uchwyt
- walizka



FESTA
POWER X TOOLS

WIERTARKA UDAROWA BEZPRZEWODOWA



N.p. specyfikacja
28000

BRUSHLESS SHARE 20V *Li-ion technology*

prędkość
0-550 min⁻¹
0-2000 min⁻¹

masa
z baterią 2,0 Ah **1,8 kg**
z baterią 4,0 Ah **2,1 kg**

moment obrotowy
80 Nm

średnica
2 - 13 mm

Zestaw zawiera:
- wiertarka udarowa
- 2,0 Ah bateria
- 2,4 A ładowarka
- dodatkowy uchwyt
- walizka



wybór trybu
wybór siły momentu obrotowego

dodatkowy uchwyt

prędkość przełącznik

szybkie wydanie
głowa średnica

przełącznik
kierunku obrotów

ergonomiczny gumowany
uchwyt dla wygodnego
i bezpiecznego chwytu

oświetlenie ledowe

haczyk do
zawieszenia

blokada baterii

FESTA
POWER X TOOLS

WIERTARKA UDAROWA BEZPRZEWODOWA

N.p. specyfikacja

28001

2

BRUSHLESS SHARE 20V

prędkość
0-550 min⁻¹
0-2000 min⁻¹

masa
bez baterii
1,4 kg

moment obrotowy
80 Nm

średnica
2 - 13 mm

Polecane akcesoria

SHARE 20V
Li-ion technology

bateria* 2 Ah - 28080

4 Ah - 28081

8 Ah - 28083

ładowarka* 2,4 A - 28085

4,0 A - 28086



wybór trybu
wybór siły momentu obrotowego

dodatkowy uchwyt

prędkość przełącznik

szybkie wydanie
głowa średnica

kierunek
przełącznika obrotów

ergonomiczny gumowany
uchwyt dla wygodnego
i bezpiecznego chwytu

oświetlenie ledowe

haczyk
do zawieszenia

FESTA
POWER X TOOLS

WIERTARKA UDAROWA BEZPRZEWODOWA

*brak baterii w zestawie

N.p. specyfikacja

28002



5

**SHARE
20V**

**Li-ion
technology**

prędkość
**0-500 min⁻¹
0-1800 min⁻¹**

masa
z baterią 2,0 Ah
1,7 kg

moment obrotowy
45 Nm

średnica
2 - 13 mm

Zestaw zawiera:

- wiertarka udarowa
- 2x 2.0 Ah Bateria
- 2.4 A ładowarka
- walizka
- nośnik i bity:
- ⊖ S5, S6 x 25 mm
- ⊕ PH1, PH2 x 25 mm
- ⊕ PZ1, PZ2 x 25 mm
- Wiertła HSS
2-2.5-3-4-5-6 mm



wybór trybu
wybór siły
momentu obrotowego

szybkie wydanie
głowa średnica

ergonomiczny gumowany
uchwyt dla wygodnego
i bezpiecznego chwytu

oświetlenie ledowe

blokada baterii

prędkość przełącznik

kierunek
przełącznika obrotów

haczyk do
zawieszenia



FESTA
POWER X TOOLS

WIERTARKA UDAROWA BEZPRZEWODOWA



N.p. specyfikacja

28003

3

**SHARE
20V**

prędkość
**0-550 min⁻¹
0-2000 min⁻¹**

masa
bez baterii
1,4 kg

moment obrotowy
45 Nm

średnica
2 - 13 mm

Polecane akcesoria

**SHARE
20V
Li-ion
technology**

bateria*
2 Ah - 28080
4 Ah - 28081
8 Ah - 28083

ładowarka*
2,4 A - 28085
4,0 A - 28086



wybór trybu
wybór siły
momentu obrotowego

szybkie wydanie
głowa średnica

ergonomiczny
gumowanyuchwyt
dla wygodnego
i bezpiecznego chwytu

oświetlenie ledowe

prędkość przełącznik

kierunek
przełącznika
obrotów

haczyk do
zawieszenia



FESTA
POWER X TOOLS

WIERTARKA UDAROWA BEZPRZEWODOWA



*brak baterii w zestawie

N.p. specyfikacja

28004

5

SHARE 20V *Li-ion technology*

prędkość
0-350 min⁻¹
0-1300 min⁻¹

masa z baterią 2,0 Ah
1,3 kg

moment obrotowy
28 Nm

średnica
1 - 10 mm

- Zestaw zawiera:
- wiertarka udarowa
 - 2x 2.0 Ah Bateria
 - 2.4 A ładowarka
 - walizka
 - nośnik i bity:
 - ⌀ S5, S6 x 25 mm
 - ⊕ PH1, PH2 x 25 mm
 - ⊕ PZ1, PZ2 x 25 mm
 - Wiertła HSS 1,5-2,5-3-4-5-6 mm



WIERTARKA AKUMULATOROWA

max 28 Nm		1.0-350min ⁻¹ 0.0-1300min ⁻¹		1-10 mm		LED	1,3 / 0,9	2x	Li-ion
-----------	--	---	--	---------	--	-----	-----------	----	--------



N.p. specyfikacja
28005



3

wybór trybu
wybór siły momentu obrotowego

szybkie wydanie głowa średnica

prędkość przełącznik

przełącznik kierunku obrotów

ergonomiczny gumowany uchwyt dla wygodnego i bezpiecznego chwytu

oświetlenie ledowe

blokada baterii

haczyk do zawieszania



SHARE 20V

prędkość
0-350 min⁻¹
0-1300 min⁻¹

masa bez baterii
0,9 kg

moment obrotowy
28 Nm

średnica
1 - 10 mm

Polecane akcesoria

- SHARE 20V** *Li-ion technology*
- bateria* 2 Ah - 28080
 - bateria* 4 Ah - 28081
 - bateria* 8 Ah - 28083
 - ładowarka* 2,4 A - 28085
 - ładowarka* 4,0 A - 28086



WIERTARKA AKUMULATOROWA

max 28 Nm		1.0-350min ⁻¹ 0.0-1300min ⁻¹		1-10 mm		LED	0,9
-----------	--	---	--	---------	--	-----	-----

*brak baterii w zestawie

N.p. specyfikacja
28006



5

wybór trybu
wybór siły momentu obrotowego

szybkie wydanie głowa średnica

prędkość przełącznik

przełącznik kierunku obrotów

ergonomiczny gumowany uchwyt dla wygodnego i bezpiecznego chwytu

oświetlenie ledowe

haczyk do zawieszania



Li-ion
technology

prędkość
0-350 min⁻¹
0-1300 min⁻¹

masa
z baterią 1,5 Ah
1 kg

moment obrotowy
20 Nm

średnica
1 - 10 mm

- Zestaw zawiera:
- wiertarka udarowa
 - 2x Bateria 12 V | 1.5 Ah
 - ładowarka 12 V | 2.4 A
 - walizka
 - nośnik i bity:
 - ⊖ S5, S6 x 25 mm
 - ⊕ PH1, PH2 x 25 mm
 - ⊕ PZ1, PZ2 x 25 mm
 - Wiertła HSS
1,5-2,5-3-4-5-6 mm



wybór trybu
wybór siły momentu
obrotowego

szybkie wydanie
głowa średnica

prędkość przelącznik

oświetlenie ledowe

wskaźnik naładowania
baterii

ergonomiczny gumowany
uchwyt dla wygodnego
i bezpiecznego chwytu

kierunek
przelącznika
obrotów

bateria



FESTA
POWER X TOOLS

WIERTARKA AKUMULATOROWA

max 20 Nm

1.0-350min⁻¹
0.0-1300min⁻¹

1-10 mm

LED

1

2x

Li-ion



N.p. specyfikacja

28007

5

Li-ion
technology

prędkość
bez obciążenia
200 min⁻¹

masa
z baterią 1,5 Ah
0,4 kg

maksymalna moment
obrotowy
3 Nm

nośnik narzędzi
1/4" hexagon

- Zestaw zawiera:
- śrubokręt
 - Ladegerät 5 V | 0,5 A
 - Träger und Bits:
 - ⊖ S5 x 50 mm
 - ⊕ PH1 x 50 mm
 - ⊕ PH2 x 50 mm
 - ⊕ H5 x 50 mm
 - ⊕ T20 x 50 mm

szybkołączka 1/4"
z bezpiecznikiem

ustawienia momentu
obrotowego

wskaźnik
naładowania baterii

blokada ustawienia
położenie uchwytu

oświetlenie ledowe

przelącznik kierunku
obrotów

ergonomiczny gumowany
uchwyt dla wygodnego
i pewny chwyt



oświetlenie ledowe



FESTA
POWER X TOOLS

BEZPRZEWODOWY ŚRUBOKRĘT

max 3 Nm

200min⁻¹

1/4"

LED

0,4

Li-ion

3,6 V

1,5 Ah



N.p. specyfikacja

28008

10

**SHARE
20V**

prędkość bez obciążenia
0-2000 min⁻¹

moment obrotowy
150 Nm

masa bez baterii
1,2 kg

number of strokes
0-3000 bpm

szybkozłączka 1/4"
z bezpiecznikiem



selectable kierunek przełącznika obrotów

ergonomiczny gumowany uchwyt dla wygodnego i pewny chwyt

haczyk do zawieszenia

oświetlenie ledowe

Polecane akcesoria

**SHARE
20V
Li-ion
technology**

- bateria* 2 Ah - 28080
- 4 Ah - 28081
- 8 Ah - 28083
- ładowarka* 2,4 A - 28085
- 4,0 A - 28086



BEZPRZEWODOWY KLUCZ UDAROWY

max 150 Nm | 0-2000min⁻¹ | 0-3000bpm | 1/4" | L R | LED | 1,2 KG

*brak baterii w zestawie

N.p. specyfikacja
28021



**SHARE
20V**

prędkość bez obciążenia
**I.0-300 min⁻¹
II.0-1000 min⁻¹**

liczba trafień
0-5000 bpm

masa bez baterii
1,7 kg

uchwyt SDS+

ogranicznik głębokości

mocowanie SDS
głowica
narzędzia

przełączanie trybu pracy
(z / bez udaru)

prędkość przełącznik

kierunek rotacji
przełącznik



**SHARE
20V
Li-ion
technology**

Polecane akcesoria

- bateria* 2 Ah - 28080
- 4 Ah - 28081
- 8 Ah - 28083
- ładowarka* 2,4 A - 28085
- 4,0 A - 28086



BEZPRZEWODOWA WIERTARKA UDAROWA

1.0-300 min⁻¹ / II.0-1000 min⁻¹ | 0-5000 bpm | 1,2J | SDS+ | L R | 1,7 KG

*brak baterii w zestawie

N.p. specyfikacja
28025



MAX Ø

beton - Ø 20 mm
metale - Ø 10 mm
drewno - Ø 20 mm



SHARE
20V

częstotliwość strzelanie
60-100 min⁻¹

maksymalna długość gwoździe / zszywki
30 mm
twarde materiały

maksymalna długość gwoździe / zszywki
50 mm
miękkie materiały

masa bez baterii
2,7 kg



SHARE
20V
Li-ion technology

Polecane akcesoria

- bateria* 2 Ah - 28080
- bateria* 4 Ah - 28081
- 8 Ah - 28083
- ładowarka* 2,4 A - 28085
- 4,0 A - 28086

Paznokcie

- 23930** Wbijanie gwoździ 30 mm, 2000 pcs
- 23931** Wbijanie gwoździ 40 mm, 2000 pcs
- 23932** Wbijanie gwoździ 50 mm, 2000 pcs

Klamra

- 23935** Klip do paznokci 30 mm, 2000 pcs
- 23936** Klip do paznokci 40 mm, 2000 pcs

Odpowiednie rodzaje gwoździ i zszywek:

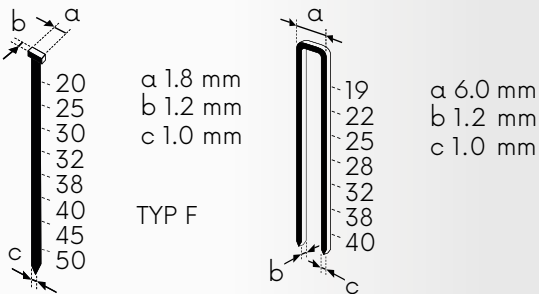

BEZPRZEWODOWA GWOŹDZIARKA I ZSZYWACZ

*brak baterii w zestawie

N.p. specyfikacja
28070



BRUSHLESS SHARE 20V

prędkość bez obciążenia
8500 min⁻¹

masa bez baterii
1,6 kg

maksymalna grubość wycięty materiał
15 mm

maksymalna średnica koła
125 mm

odpowietzniki silnika

ergonomiczny gumowany uchwyt dla wygodnego i bezpiecznego chwytu

blokada obrotu

bezpiecznik przełącznik operacyjny

szybkie wydanie mechanizm pokrywa ochronna

nakrętki mocujące koła

SHARE 20V
Li-ion technology

Polecane akcesoria

bateria* 2 Ah - 28080

bateria* 4 Ah - 28081

bateria* 8 Ah - 28083

ładowarka* 2,4 A - 28085

ładowarka* 4,0 A - 28086



AKUMULATOROWA SZLIFIERKA KĄTOWA

8500 min ⁻¹	max 125mm	M14	L R	KG 1,6
------------------------	--------------	-----	-----	-----------

*bateria and disc are not included

N.p. specyfikacja

28030



4

SHARE 20V

prędkość bez obciążenia
8000 min⁻¹

masa bez baterii
1,6 kg

maksymalna grubość wycięty materiał
15 mm

maksymalna średnica koła
115 mm

ergonomiczny gumowany uchwyt dla wygodnego i bezpiecznego chwytu

blokada obrotu

bezpiecznik przełącznik operacyjny

szybkie wydanie mechanizm pokrywa ochronna

nakrętki mocujące koła

SHARE 20V
Li-ion technology

Polecane akcesoria

bateria* 2 Ah - 28080

bateria* 4 Ah - 28081

bateria* 8 Ah - 28083

ładowarka* 2,4 A - 28085

ładowarka* 4,0 A - 28086



AKUMULATOROWA SZLIFIERKA KĄTOWA

8000 min ⁻¹	max 115mm	M14	L R	KG 1,6
------------------------	--------------	-----	-----	-----------

*bateria and disc are not included

N.p. specyfikacja

28032



4

SHARE 20V

prędkość
bez obciążenia
10000 min⁻¹

masa
bez baterii
1 kg

ekscentryczność
koła
5 mm

średnica
koła
125 mm

SHARE 20V Li-ion technology

Polecane akcesoria

bateria* 2 Ah - 28080
4 Ah - 28081
8 Ah - 28083

ładowarka* 2,4 A - 28085
4,0 A - 28086



FESTA
POWER X TOOLS

SZLIFIERKA OSCYLACYJNA BATERIA



*brak baterii w zestawie

N.p. specyfikacja
28040



4



SHARE 20V

liczba
oscylacje
bez obciążenia
5000-15000 min⁻¹

masa
bez baterii
1 kg

prędkość kontrola



SHARE 20V Li-ion technology

Polecane akcesoria

bateria* 2 Ah - 28080
4 Ah - 28081
8 Ah - 28083

ładowarka* 2,4 A - 28085
4,0 A - 28086



FESTA
POWER X TOOLS

BEZPRZEWODOWE URZĄDZENIE WIELOFUNKCYJNE



*brak baterii w zestawie

N.p. specyfikacja
28045



4

SHARE
20V

ergonomiczny gumowany uchwyt
dla wygodnego i bezpiecznego chwytu

wyłącznik operacyjny bezpiecznik

okładka dysku

połączenie
zewnętrzny
sanie

regulacja kąta
nachylenia cięcia
45-90 stopni

baza

wał 16 mm



prędkość
bez obciążenia
3650 min⁻¹

nastawny
kąt nachylenia
cięcia
45-90 degrees

max. średnica
koła
165 mm
(ø16 mm)

maksymalne
cięcie
50 mm
* pod kątem 90 stopni
ø165 mm

skala głębokość
cięcia





blokada obrotu

ustawienie głębokości cięcia

SHARE
20V
Li-ion
technology

Polecane akcesoria

	2 Ah - 28080	
bateria*	4 Ah - 28081	
	8 Ah - 28083	
	2,4 A - 28085	
ładowarka*	4,0 A - 28086	

FESTA
POWER X TOOLS

AKUMULATOROWA PIŁA TARCZOWA

Zestaw zawiera:

- Piła tarczowa
- przewód boczny
- klucz
- brzeszczot



szyna prowadząca



22314

N.p. specyfikacja

28035



2

**SHARE
20V**liczba uderzeń
ostrza**0-2400 min⁻¹**masa
bez baterii
1,8 kgmaks. kąt
cięcia skośne
45 stopniemaks. cięcia
profil**Stal: 6 mm
Drewno: 80 mm****Polecane akcesoria****SHARE
20V
Li-ion
technology**

bateria* 2 Ah - 28080

bateria* 4 Ah - 28081

8 Ah - 28083

ładowarka* 2,4 A - 28085

4,0 A - 28086

**FESTA
POWER X TOOLS****WYRZYNARKA BEZPRZEWODOWA**

*brak baterii w zestawie

N.p. specyfikacja
28050ergonomiczny gumowany uchwyt dla
wygodnego i bezpiecznego chwytubezpiecznik
przełącznik
operacyjnyoscylacja wstępna
ustawienie

LED

blokada paska

szyna prowadząca

łapa
blokada
zbocza

baza

ukosować cięcie

0°
45° 45°**SHARE
20V**liczba
drżania bez
obciążenia**0-3000 min⁻¹**masa
bez baterii
1,7 kg

maks. grubość cięcia

Drewno: 100 mm**Stal: 5 mm****aluminium/
miedź: 20 mm****Polecane akcesoria****SHARE
20V
Li-ion
technology**

bateria* 2 Ah - 28080

bateria* 4 Ah - 28081

8 Ah - 28083

ładowarka* 2,4 A - 28085

4,0 A - 28086

**FESTA
POWER X TOOLS****BEZPRZEWODOWA PIŁA SZABLASTA**

*brak baterii w zestawie

N.p. specyfikacja
28055bezpiecznik
przełącznik
operacyjnyergonomiczny gumowany uchwyt
dla wygodnego i bezpiecznego
chwytuszybkie wydanie
ostrze piły

SHARE 20V

maks. ciśnienie
8,2 bar

manometr
psi, bar,
kgf/cm², kPa

szlach
600 mm

woltaż
20 V

podświetlany
wyświetlacz
manometru



ergonomiczny
gumowany uchwyt
dla wygodnego i
bezpiecznego chwytu

szybkozamykający uchwyt
do pompowania opon

adapter
do akumulatora
samochodowego 3 m



adaptery

Zestaw zawiera:
- kompresor
- zasilacz z akumulatora samochodowego
- 3x adaptery do pompowania

szlach
Ø 10,5 x 600 mm

Lampa LED



Polecane akcesoria

SHARE
20V
Li-ion
technology

bateria*
2 Ah - 28080
4 Ah - 28081
8 Ah - 28083

ładowarka*
2,4 A - 28085
4,0 A - 28086



FESTA
POWER X TOOLS

KOMPRESOR

*brak baterii w zestawie

N.p. specyfikacja

28075

48013 **NEW** adaptery



1

1



NEW
 horyzontalny pozycja 110 kg
 pionowy pozycja 80 kg
 Ø 220 mm
 USB-C



FESTA
 POWER X TOOLS

PRZYSSAWKA AKU

Ø 220 mm	80 kg	110 kg	ROUGH SURFACE	USB-C	Li-ion 3.6V 2Ah
----------	-------	--------	---------------	-------	--------------------

N.p. specyfikacja
36326



SHARE 20V

ładowność 60 kg
 waga 3 kg
 woltaż 20 V
 wibracja 12 poziomów regulacji, 3500 - 8500 r/min

ergonomiczny gumowany uchwyt dla wygodnego i bezpiecznego chwytu



podświetlany wyświetlacz



przysawka Ø 125 mm



dźwignia blokująca przysawkę



Polecane akcesoria

SHARE 20V
 Li-ion technology

- bateria* 2 Ah - 28080
- 4 Ah - 28081
- 8 Ah - 28083
- ładowarka* 2,4 A - 28085
- 4,0 A - 28086

- Zestaw zawiera:
- wibrator do płytek
 - akumulator 2,0 Ah (tylko 36328)
 - ładowarka (tylko 36328)
 - sprawa

FESTA
 POWER X TOOLS

WIBRATOR DO PŁYTEK

N.p.	specyfikacja	
36328	z akumulatorem 2Ah i ładowarką	1
36329	bez akumulatora i ładowarki	1



SHARE
20V

regulowana prędkość
0-8,7 mm/s

waga
1,7 kg

woltaż
20 V

moment obrotowy
6500 N



pojemność 310 ml

spust o zmiennej prędkości

LED light

ergonomiczny gumowany uchwyt dla wygodnego i bezpiecznego chwytu



Polecane akcesoria

SHARE
20V
Li-ion technology

bateria* 2 Ah - 28080
4 Ah - 28081
8 Ah - 28083

ładowarka* 2,4 A - 28085
4,0 A - 28086



PISTOLET DO USZCZELNIANIA

*brak baterii w zestawie

N.p.	specyfikacja
28060	



1



600 ml



ZAPASOWY WKŁAD USZCZELNIAJĄCY

for 28060

N.p.	specyfikacja
28061	600 ml



1



SHARE
20V

temperatura koloru
5000 K

masa bez baterii
0,9 kg

strumień świetlny
2000 lm (100%)

moc diody LED
20W



Polecane akcesoria

SHARE
20V
Li-ion technology

bateria* 2 Ah - 28080
4 Ah - 28081
8 Ah - 28083

ładowarka* 2,4 A - 28085
4,0 A - 28086

ustawienie natężenia światła
50%, 100%



regulacja głowicy obrotowej 360°



ŚWIATŁO LED AKU

20W	2000 lumen	IP20	0,9 KG
-----	------------	------	--------

*brak baterii w zestawie

N.p.	specyfikacja
28065	



2

**SHARE
20V**

tuner
DAB+ / FM / BT

moc
2x 15 W

odporność
na wnikanie wody
IP54

voltage
20 V



USB do ładowania 5V



bateria **SHARE
20V**

Antena FM



kolorowy
wyświetlacz

Polecane akcesoria

**SHARE
20V**
Li-ion
technology

- bateria* 2 Ah - 28080
- 4 Ah - 28081
- 8 Ah - 28083
- ładowarka* 2,4 A - 28085
- 4,0 A - 28086



AUX IN jack 3,5 mm

głośniki stereo



zasilacz 230V



**FESTA
POWER X TOOLS**

RADIO DAB+ / FM / BT

- stereo
- DAB+/FM
- Wejście zewnętrzne Bluetooth V5.0 / AUX IN Gniazdo 3,5 mm
- odporność na wnikanie wody IP54
- 30 pamięci (30 dla DAB / 30 dla FM)
- USB do ładowania
- Kolorowy wyświetlacz 2,4".
- moc 2x 15 W
- 20 V / 1,3 A
- Zasilacz

*brak baterii w zestawie

N.p. specyfikacja
28076



SHARE
20V

2,0 Ah



4,0 Ah

FESTA
POWER X TOOLS

ŁADOWARKA 20 V I 2,4 A

N.p. specyfikacja
28085 220 – 240 V, 50 – 60 Hz, 70 W

20

SHARE
20V

2,0 Ah



4,0 Ah



8,0 Ah

FESTA
POWER X TOOLS

ŁADOWARKA 20 V I 4,0 A

N.p. specyfikacja
28086 *220 – 240 V, 50 – 60 Hz, 105 W

20

SHARE
20V *Li-ion
technology*FESTA
POWER X TOOLS

wskaźnik naładowania baterii



BATERIA 20 V I 2,0 Ah

20V	2,0 Ah	Li-ion		0,4
-----	-----------	--------	--	-----

N.p. specyfikacja
28080

20

SHARE
20V *Li-ion
technology*FESTA
POWER X TOOLS

wskaźnik naładowania baterii



BATERIA 20 V I 4,0 Ah

20V	4,0 Ah	Li-ion		0,7
-----	-----------	--------	--	-----

N.p. specyfikacja
28081

20

SHARE
20V *Li-ion
technology*FESTA
POWER X TOOLS

wskaźnik naładowania baterii



NEW

BATERIA 20 V I 8,0 Ah

20V	8,0 Ah	Li-ion		1,0
-----	-----------	--------	--	-----

N.p. specyfikacja
28083

20

SHARE
20V *Li-ion*
technology

28080



28085



PRZECENIONA
CENA

FESTA
POWER X TOOLS

ZESTAW BEZPRZEWODOWY Z TORBĄ KOMPLET 2+3

28080 - Bateria do narzędzi akumulatorowych FESTA SHARE20V 2,0 Ah
28085 - Ładowarka FESTA SHARE20V 2,4 A

N.p. specyfikacja

28090

1

SHARE
20V *Li-ion*
technology

28004
strona 6



28025
strona 9



37330



28030
strona 12



BRUSHLESS

PRZECENIONA
CENA
+GRATIS TORBA

FESTA
POWER X TOOLS

ZESTAW BEZPRZEWODOWY Z TORBĄ KOMPLET 3+3

28004 - Wiertarko-wkrętarka akumulatorowa z młotkiem FESTA SHARE20V
28025 - Wiertarka udarowa Bezprzewodowa FESTA SDS+ SHARE20V
28030 - Szlifierka kątowna akumulatorowa FESTA „BRUSHLESS” SHARE20V 125 mm
28080 - Bateria do narzędzi akumulatorowych FESTA SHARE20V 2,0 Ah
28081 - Bateria do narzędzi akumulatorowych FESTA SHARE20V 4,0 Ah
28086 - Ładowarka FESTA SHARE20V 4,0 A

28080
strona 18



28081
strona 18



28086
strona 18



N.p. specyfikacja

28102

1

BRUSHLESS **SHARE**
20V *Li-ion*
technology

28002
strona 5



37330



28030
strona 12



PRZECENIONA
CENA
+GRATIS TORBA

FESTA
POWER X TOOLS

ZESTAW BEZPRZEWODOWY Z TORBĄ KOMPLET 2+3

28002 - Wiertarko-wkrętarka akumulatorowa z młotkiem FESTA SHARE20V
28030 - Szlifierka kątowna akumulatorowa FESTA „BRUSHLESS” SHARE20V 125 mm
28080 - Bateria do narzędzi akumulatorowych FESTA SHARE20V 2,0 Ah
28081 - Bateria do narzędzi akumulatorowych FESTA SHARE20V 4,0 Ah
28086 - Ładowarka FESTA SHARE20V 4,0 A

28080
strona 18



28081
strona 18



28086
strona 18



N.p. specyfikacja

28103

1

SHARE
20V *Li-ion technology*

28004
strona 6

28032
strona 12

28055
strona 15

28035
strona 14

37330

28040
strona 13

PRZECENIONA
CENA
+GRATIS TORBA

FESTA
POWER X TOOLS

ZESTAW BEZPRZEWODOWY Z TORBĄ KOMPLET 5+3

- 28004 - Wiertarko-wkrętarka akumulatorowa z młotkiem FESTA SHARE20V
- 28032 - Szlifierka kątowna akumulatorowa FESTA SHARE20V 115 mm
- 28035 - Pilarka tarczowa akumulatorowa FESTA SHARE20V 165 mm/d 16 mm
- 28040 - Szlifierka mimośrodowa akumulatorowa FESTA SHARE20V 125 mm 8 otv.
- 28055 - Piła do metalu Bezprzewodowa FESTA SHARE20V
- 28080 - Bateria do narzędzi akumulatorowych FESTA SHARE20V 2,0 Ah
- 28081 - Bateria do narzędzi akumulatorowych FESTA SHARE20V 4,0 Ah
- 28086 - Ładowarka FESTA SHARE20V 4,0 A



- 28080 strona 18
- 28081 strona 18
- 28086 strona 18

N.p. specyfikacja

28101



1

SHARE
20V *Li-ion technology*

BRUSHLESS

28002
strona 5

28030
strona 12

28040
strona 13

BRUSHLESS

37330

28055
strona 15

28035
strona 14

PRZECENIONA
CENA
+GRATIS TORBA

FESTA
POWER X TOOLS

ZESTAW BEZPRZEWODOWY Z TORBĄ KOMPLET 5+3

- 28002 - Wiertarko-wkrętarka akumulatorowa z młotkiem FESTA SHARE20V
- 28030 - Szlifierka kątowna akumulatorowa FESTA „BRUSHLESS” SHARE20V 125 mm
- 28035 - Pilarka tarczowa akumulatorowa FESTA SHARE20V 165 mm/d 16 mm
- 28040 - Szlifierka mimośrodowa akumulatorowa FESTA SHARE20V 125 mm 8 otv.
- 28055 - Piła do metalu Bezprzewodowa FESTA SHARE20V
- 28080 - Bateria do narzędzi akumulatorowych FESTA SHARE20V 2,0 Ah
- 28081 - Bateria do narzędzi akumulatorowych FESTA SHARE20V 4,0 Ah
- 28086 - Ładowarka FESTA SHARE20V 4,0 A

- 28080 strona 18
- 28081 strona 18
- 28086 strona 18

N.p. specyfikacja

28104



1

BRUSHLESS

narzędzie jest zasilane
bezsztotkowy silnik prądu stałego

moment obrotowy



prędkość



kierunek do wyboru
rotacji



średnica



wiercenie, wiercenie udarowe



liczba uderzeń na minutę



wiercenie, wkręcanie



masa
z/bez baterii



sposób mocowania



sposób mocowania



sposób mocowania



ekscentryczność dysku



sterowanie urządzeniem dla
prawej i lewej ręki



spełnia ten standard



strumień świetlny



kierunkowy kąt padania światła



maksymalna
częstotliwość strzelania

**SHARE
20V**

narzędzie jest kompatybilne
z obiema Bateriami

odpowiednie rodzaje paznokci



odpowiednie rodzaje sprzączek



ściernica
z otworami



maksymalna średnica koła



średnica koła



maksymalna grubość cięcia
materiał: drewno



maksymalna grubość cięcia
materiał: stal



ustawienie oscylacji wstępnej



mocowanie piły



liczba uderzeń ostrza



możliwość fazowania
cięć



szybkie zwolnienie
brzeszczotu



liczba oscylacji piły



oświetlenie ledowe



pojemność baterii



bateria



czas ładowania
bateria



NEW

prędkość
520 min⁻¹

BPM / uderzenie
0 - 4100 / 12 J

moc
1500 W

uchwyt
SDS MAX



MAX ø beton - ø 40 mm



ogranicznik
głębokości

system redukcji
drgań

ergonomiczny
gumowany uchwyt
dla wygodnego i
bezpiecznego
chwytu



osłona przeciwpłyowa

Uchwyt
SDS MAX



dotychczasowy uchwyt



3.0m

FESTA
POWER X TOOLS

WIERTARKA UDAROWA SDS MAX

Zestaw zawiera:

- wiertarka udarowa
- uchwyt boczny
- wskaźnik głębokości
- osłona przeciwpłyowa
- klucz
- plastikowa obudowa
- zapasowe szczotki węglowe
- akcesoria SDS MAX:

ø 16 x 280 mm
| 18 x 320 mm

zapasowe szczotki
węglowe 2 szt - 28229



FESTA
POWER X TOOLS

N.p. specyfikacja
28221

prędkość
0-850 min⁻¹

BPM / uderzenie
0-4500 / 6 J

moc
1500 W

uchwyt
SDS+



MAX Ø

beton - ø 32 mm
metale - ø 13 mm
drewno - ø 40 mm



ogranicznik
głębokości

system redukcji
drgań

ergonomiczny
gumowany uchwyt
dla wygodnego i
bezpiecznego
chwytu

Uchwyt SDS+

dotatkowy uchwyt



2.0m

FESTA
POWER X TOOLS

WIERTARKA UDAROWA

Zestaw zawiera:

- wiertarka udarowa
- uchwyt boczny
- wskaźnik głębokości
- klucz
- plastikowa obudowa
- zapasowe szczotki węglowe
- akcesoria SDS+:

Ø 8, 10, 12 x 160 mm

20 x 250 mm

14 x 250 mm



zapasowe szczotki
węglowe 2 szt - 28228



230V ~ 50Hz	1500W	0-4500 bpm	0-850 min ⁻¹	6J	SDS+	2m RUBBER	5.0 KG
----------------	-------	---------------	-------------------------	----	------	--------------	-----------

N.p. specyfikacja
28225



prędkość
0-1350 min⁻¹

BPM / uderzenie
0-5500 / 2,8 J

moc
800 W

uchwyt
SDS+
ø 2 - 13 mm



MAX ø

beton - ø 25 mm
metale - ø 13 mm
drewno - ø 30 mm



FESTA
POWER X TOOLS

WIERTARKA UDAROWA

- Zestaw zawiera:
- wiertarka udarowa
 - uchwyt boczny
 - wskaźnik głębokości
 - uchwyt ø 2 - 13 mm
 - plastikowa obudowa
 - wazelina
 - zapasowe szczotki węglowe
 - akcesoria SDS+:

- ø 6, 8, 10 x 160 mm
- 20 x 250 mm
- 14 x 250 mm



zapasowe szczotki węglowe 2 szt - 28223

230V ~ 50Hz	800W	0-5500 bpm	0-1350 min ⁻¹	2.8J	SDS+	2m RUBBER	KG 3.2
----------------	------	------------	--------------------------	------	------	-----------	--------

N.p. specyfikacja
28220



prędkość
0-4500 min⁻¹

waga
4,3 kg

moc
1400 W

max.
średnica koła
max ø 185 mm / ø 20 mm



max. 63 mm



ergonomiczny gumowany uchwyt dla wygodnego i bezpiecznego chwytu



max. 45°

ogranicznik boczny 6 - 120 mm



odpylanie ø 35 mm

2.0m

FESTA
POWER X TOOLS

PIŁA TARCZOWA

- Zestaw zawiera:
- Piła tarczowa
 - przewódnik boczny
 - klucz
 - zapasowe szczotki węglowe
 - brzeszczot ø 185 x 2,3/1,3 x 20 mm 24T (22316)



22316

1400W	230V ~ 50Hz	4500 min ⁻¹	ø 20 1 mm MAX 185mm	90° 63mm	45° 42mm	KG 4.3
-------	----------------	------------------------	---------------------------	-------------	-------------	-----------

zapasowe szczotki węglowe 2 szt - 28233



N.p. specyfikacja
28230

prędkość
6600 min⁻¹

masa
5,8 kg

moc
2400 W

maksymalna
średnica koła
M14
max ø 230 mm



ergonomiczny gumowany uchwyt dla wygodnego i bezpiecznego chwytu

SOFT START

miękki start



osłona tarczy



FESTA
POWER X TOOLS

SZLIFIERKA KĄTOWA

- Zestaw zawiera:
- szlifierka kątowa
 - osłona ochronna
 - uchwyt boczny
 - klucz
 - zapasowe szczotki węglowe



zapasowe szczotki węglowe 2 szt - 28218



N.p. specyfikacja
28215

2

prędkość
11000 min⁻¹

masa
2 kg

moc
900 W

maksymalna
średnica koła
M14
max ø 125 mm

dodatkowy uchwyt



bezpiecznik
przełącznik operacyjny

SOFT START
miękki start



osłona tarczy

FESTA
POWER X TOOLS

SZLIFIERKA KĄTOWA

- Zestaw zawiera:
- szlifierka kątowa
 - osłona ochronna
 - uchwyt boczny
 - klucz
 - zapasowe szczotki węglowe



900W	230V ~ 50Hz	11000min⁻¹	M14	max ø 125mm	2.0m RUBBER	KG 2.0		zapasowe szczotki węglowe 2 szt - 28213		
-------------	-----------------------	------------------------------	------------	--------------------	--------------------	---------------	--	--	--	--

N.p. specyfikacja
28210

8

FESTA
POWER X TOOLS

ZAPASOWE SZCZOTKI WĘGLOWE

2x



N.p.	specyfikacja	
28229	dla 28221	1
28228	dla 28225	1
28223	dla 28220	1
28233	dla 28230	1
28213	dla 28210	1
28218	dla 28215	1



ADAPTER SDS MAX / SDS+

	→		
N.p.	specyfikacja		
20744			1



ADAPTER SDS+ / 1/2" UNF

N.p.	specyfikacja	
20745		1



FESTA
ADAPTER SDS + BIT 1/4"

	→			
N.p.	Specyfikacja			
20743	75 mm		20	



FESTA
GŁOWICA WIERTARSKA

N.p.	specyfikacja	
20960	1-13 mm + 2 klíče, 1/2 - 20 UNF	3
20966	zapasowy klucz	25



FESTA
GŁOWICA WIERTARSKA

N.p.	specyfikacja	
20965	1,5 - 13 mm 1/2' - 20 UNF	1



GŁOWICA WIERTARSKA

N.p.	specyfikacja	
20961	1,5 - 13 mm 1/2' - 20 UNF	1



PRZYSTAWKA KĄTOWA DO WIERTARKI 90°

N.p.	specyfikacja	
20365	Ø 1 - 10 mm	10



UCHWYT WIERTARSKI SZYBKOMOCUJĄCY DO AKU

N.p.	specyfikacja	
20963	Ø 1 - 6 mm	10



FESTA
ODKURZACZ

N.p.	specyfikacja	
28267	max. 70 mm	1

SZABLON NA WIERTŁA

N.p.	specyfikacja	
20379	Ø 4, 5, 6, 7, 8, 10, 12 mm	10

TECHNICZNY SPECYFIKACJE



NUMER KATALOGOWY PRODUKTU	28000	28001	28002	28003	28004
Nazwa	Wiertarka udarowa bezprzewodowa	Wiertarka udarowa bezprzewodowa	Wiertarka udarowa bezprzewodowa	Wiertarka udarowa bezprzewodowa	Wiertarka udarowa bezprzewodowa
prędkość bez obciążenia	I.0-550 min ⁻¹ II.0-2000 min ⁻¹	I.0-550 min ⁻¹ II.0-2000 min ⁻¹	I.0-550 min ⁻¹ II.0-2000 min ⁻¹	I.0-500 min ⁻¹ II.0-1800 min ⁻¹	I.0-500 min ⁻¹ II.0-1800 min ⁻¹
Liczba trafień	I.0-8800min ⁻¹ II.0-32000min ⁻¹	I.0-8800min ⁻¹ II.0-32000min ⁻¹	I.0-8800min ⁻¹ II.0-32000min ⁻¹	0-19200 min ⁻¹	0-19200 min ⁻¹
Liczba uderzeń					
Moment obrotowy	80 Nm	80 Nm	80 Nm	45 Nm	45 Nm
Maks. napięcie baterii	20V	20V	20V	20V	20V
Liczba stopni obrotowych momentu	20+1+1	20+1+1	20+1+1	19+1+1	19+1+1
Głowica mocująca	2-13 mm	2-13 mm	2-13 mm	2-13 mm	2-13 mm
Waga bez baterii	1,4kg	1,4kg	1,4kg	1,3kg	1,3kg
Pokrywa	IPX0	IPX0	IPX0	IPX0	IPX0
Poziom ciśnienia akustycznego niepewność K	LpA=97,04dB(A) K=5dB(A)	LpA=97,04dB(A) K=5dB(A)	LpA=97,04dB(A) K=5dB(A)	LpA=79dB(A) K=5dB(A)	LpA=79dB(A) K=5dB(A)
Poziom mocy akustycznej niepewność K	LwA=86,04dB(A) K=5dB(A)	LwA=86,04dB(A) K=5dB(A)	LwA=86,04dB(A) K=5dB(A)	LwA=90dB(A) K=5dB(A)	LwA=90dB(A) K=5dB(A)
Wibracje bez uderzenia w metal	$\alpha_{h,D}=3,9m/s^2$ K=1,5m/s ²	$\alpha_{h,D}=3,9m/s^2$ K=1,5m/s ²	$\alpha_{h,D}=3,9m/s^2$ K=1,5m/s ²	$\alpha_{h,D}=2,4m/s^2$ K=1,5m/s ²	$\alpha_{h,D}=2,4m/s^2$ K=1,5m/s ²
Wibracje bez uderzenia w beton	$\alpha_{h,ID}=11,4m/s^2$ K=1,5m/s ²	$\alpha_{h,ID}=11,4m/s^2$ K=1,5m/s ²	$\alpha_{h,ID}=11,4m/s^2$ K=1,5m/s ²	$\alpha_{h,ID}=7,5m/s^2$ K=1,5m/s ²	$\alpha_{h,ID}=7,5m/s^2$ K=1,5m/s ²
Maksymalna wibracja, niepewność K					
Siła uderzenia					
Średnica wiercenia					
Wibracje w betonie -główny uchwyt					
Wibracje w betonie - dodatkowy uchwyt					
Zawartość Paczki	wiertarka, 2.4 A ładowarka, bateria 2.0 Ah, 4.0 Ah bateria, dodatkowy uchwyt, walizka	wiertarka, łado- warka 2.4 A, bateria 2.0 Ah, dodatkowy uchwyt, walizka	wiertarka	wiertarka, 2.4 A ładowarka, 2x 2.0 Ah bateria, 6x bit, nośnik, 6x wiertarka, walizka	wiertarka



28005	28006	28007	28008	28021	28025
Wiertarka akumulatorowa	Wiertarka akumulatorowa	Wiertarka akumulatorowa	Bezprzewodowy śrubokręt	Bezprzewodowy klucz udarowy	Bezprzewodowa wiertarka udarowa
I.0-350 min ⁻¹ II.0-1300 min ⁻¹	I.0-350 min ⁻¹ II.0-1300 min ⁻¹	I.0-350 min ⁻¹ II.0-1300 min ⁻¹	200 min ⁻¹	0-2000 min ⁻¹	I.0-300 min ⁻¹ II.0-1000 min ⁻¹
					0-5000bpm
				0-3000bpm	
28 Nm	28 Nm	20 Nm	3 Nm	150 Nm	
20V	20V	12V	3.6V	20V	20V
19+1	19+1	19+1	6+1		
1-10mm	1-10mm	1-10mm	1/4" hexagon	1/4" hexagon	SDS+
0,9kg	0,9kg	*1kg	*0,4kg	1,2kg	1,7kg
IPX0	IPX0	IPX0	IPX0	IPX0	IPX0
LpA=69dB(A) K=5dB(A)	LpA=69dB(A) K=5dB(A)	LpA=78dB(A) K=5dB(A)	LpA=58dB(A) K=3dB(A)	LpA=92dB(A) K=3dB(A)	LpA=82,98dB(A) K=3dB(A)
LwA=80dB(A) K=5dB(A)	LwA=80dB(A) K=5dB(A)	LwA=67dB(A) K=5dB(A)	LwA=69dB(A) K=3dB(A)	LwA=103dB(A) K=3dB(A)	LwA=93,98dB(A) K=3dB(A)
$\alpha_{h,D} < 1,9m/s^2$ K=1,5m/s ²	$\alpha_{h,D} < 1,9m/s^2$ K=1,5m/s ²	$\alpha_{h,D} = 2,1m/s^2$ K=1,5m/s ²			
$\alpha_{h,D} = 10,1m/s^2$ K=1,5m/s ²	$\alpha_{h,D} = 10,1m/s^2$ K=1,5m/s ²	$\alpha_{h,D} = 7,5m/s^2$ K=1,5m/s ²			
			$\alpha_h < 2,5m/s^2$ K=1,5m/s ²	$\alpha_{h,D} = 15,9m/s^2$ K=1,5m/s ²	
					1,2J
					Stal: 10mm concrete: 20mm Drewno: 20mm
					$\alpha_{h,(HD)} = 5,582m/s^2$ K=1,5m/s ²
					$\alpha_{h,(HD)} = 5,523m/s^2$ K=1,5m/s ²
wiertarka, 2.4 A ładowarka, 2x 2.0 Ah bateria, 6x bit, carrier, 6x drill, walizka	wiertarka	wiertarka, 2.4 A ładowarka, 2x 1.5 Ah Bateria, 6x bits, carrier, 6x drill, walizka	screwdriver, ładowarka 0.5 A, 1.5 Ah bateria, 5x bit	napinacz	młot wiertniczy, dodatkowy uchwyt, ogranicznik głębokości

* waga jest podana łącznie z baterią

TECHNICZNY SPECYFIKACJE



NUMER KATALOGOWY PRODUKTU	28030	28032	28035	28040
Nazwa	Kątownik bezprzewodowy szlifierka	Akumulatorowa szlifierka kątowa	Bezprzewodowa okrągła piła	Bateria orbitalna szlifierka
Prędkość bez obciążenia	8500 min ⁻¹	8000 min ⁻¹	3650 min ⁻¹	10000 min ⁻¹
Liczba oscylacji bez obciążenia				
Do przodu				
Liczba stopni wstępnej oscylacji				
Liczba ostrzy brzeszczotu				
Maksymalne cięcie profile				
Maksymalna średnica koła	125 mm	115 mm		
Dysk pomocniczy				125 mm
8 otworów ssanie na okręgu				65 mm
Ekscentryczność koła				5 mm
Rozmiar gwintu wrzeciona	M14	M14		
Maksymalna grubość ciętego materiału	15 mm	15 mm		
Maks. napięcie baterii	20V	20V	20V	20V
Regulowany kąt cięcia			0-45°	
Cięcie pod kątem 45°			35 mm	
Cięcie pod kątem 90°			50 mm	
Kąt oscylacji				
Wymiar szlifowania delta Baza				
Kontrola prędkości drgań				
Mocowanie brzeszczotu				
Skok brzeszczotu				
Rozmiar talerza Baza			28 cm x 13,3 cm	
Waga bez obrażeń	1,6kg	1,6kg	2,7kg	1kg
Średnica koła			165 mm	
Grubość korpusu koła			1,4 mm ± 5% mm	
Grubość SK ostrza ostrza			2,0 ± 5% mm	
Szerokość cięcia			2,3 ± 5% mm	
Średnica otworu koła po zamocowaniu			16 mm	
Liczba zębów tarczy			24	
Pokrywa	IPX0	IPX0	IPX0	IPX0
Typ Paznokcie, wysokość x szerokość x grubość				
Klamras-rozpiętość x wysokość x szerokość x grubość				
Maks. długość Paznokcie/wpina się w miękkie maty.				
Maks. dł. Paznokcie / klipsy w twarde mat.				
Średnia / maks. częstotliwość strzelania				
Czas pracy (akumulator 4 AH, w pełni naładowany)				
Pojemność magazynka na gwoździe / zszywki				
Poziom ciśnienia akustycznego niepewność k	LpA=87,1dB(A) K=3dB(A)	LpA=76,67dB(A) K=3dB(A)	LpA=84dB(A) K=3dB(A)	LpA=76dB(A) K=3dB(A)
Poziom mocy akustycznej niepewność k	LwA=98,1dB(A) K=3dB(A)	LwA=87,67dB(A) K=3dB(A)	LwA=95dB(A) K=3dB(A)	LwA=87dB(A) K=3dB(A)
Wibracje podczas szlifowania powierzchni	$a_{h,AG}=8,363m/s^2$ K=1,5m/s ²	$a_{h,AG}=5,324m/s^2$ K=1,5m/s ²		
Wibracja do cięcia deski				
Wibracje przy cięciu blach				
Wibrator do cięcia ramek Drewno:en				
Maksymalna wibracja, niepewność K			$a_h < 2,5m/s^2$ K=1,5m/s ²	$a_h = 9,5m/s^2$ K=1,5m/s ²
Zawartość Paczki	szlifierka, osłona koła, dodatkowy uchwyt, klucz	szlifierka, osłona koła, dodatkowy uchwyt, klucz	widział, ogranicznik głębokości, ostrze piły	szlifierka, pracował do zbierania kurzu



28045	28050	28055	28070
Urządzenie bezprzewodowe wielofunkcyjny	Wyrzynarka bezprzewodowa	Bezprzewodowa piła szablasta	Bezprzewodowa gwoździarka i zszywacz
5000-15000 min ⁻¹		0-3000 min ⁻¹	
		1°	
	3+0		
	0-2400 min ⁻¹		
	Stal: 6mm, Drewno: 80mm	Drewno: 100 mm, Stal: 5 mm, aluminium / miedź: 20 mm	
20V		20V	20V
	cięcie ukośne maks. 45°		
3°			
90 mm			
tak			
uniwersalny		uniwersalny	
		20 mm	
1kg	1,8kg	1,7kg	2,7kg
IPX0	IPX0	IPX0	IPX0
			F, 20-50mm x 1,2mm x 1,0 mm
			6,0mm x 19-40mm x 1,2mm x 1,0mm
			50 mm
			30 mm
			60/100 min ⁻¹
			1 godzina
			100 sztuki
LpA=78dB(A) K=3dB(A)	LpA=88,1dB(A) K=5dB(A)	LpA=87,33dB(A) K=5dB(A)	LpA=79,9dB(A) K=3dB(A)
LwA=89dB(A) K=3dB(A)	LwA=99,1dB(A) K=5dB(A)	LwA=98,33dB(A) K=5dB(A)	LwA=90,9dB(A) K=3dB(A)
	$\alpha_{h,B}=3,3m/s^2$ $K=1,5m/s^2$ $\alpha_{h,M}=4m/s^2$ $K=1,5m/s^2$	$\alpha_{h,B}=21,10m/s^2$ $K=1,5m/s^2$	
		$\alpha_{h,WB}=21,98m/s^2$ $K=1,5m/s^2$	
$\alpha_h=2,8m/s^2$ $K=1,5m/s^2$			$\alpha_h=1,39m/s^2$ $K=1,5m/s^2$
szlifierka, osprzet (piła, skrobak, nośnik), 3x papier ścierny P80	piła, Führungsschiene, przywiązanie sanie, 2x brzeszczot	piła, 2x brzeszczot	gwoździarka / zszywacz, 200x Paznokcie, 200x zszywki

TECHNICZNY
SPECYFIKACJE

NUMER KATALOGOWY PRODUKTU	28075	36328	36329	28060	28076
Nazwa	kompresor	wibrator do płytek	wibrator do płytek	pistolet do uszczelniania	radio AKU DAB+ / FM / BT
Manometr	psi; bar; kgf/cm ² ; kPa				
Maks. Ciśnienie	120 psi / 8,2 bar				
Szlach	ø 10,5 x 600 mm				
Przyssawka		Ø 123 mm	Ø 123 mm		
Ładowność		60 kg	60 kg		
Wibracja		12 poziomów regulacji 3500 - 8500 r/min	12 poziomów regulacji 3500 - 8500 r/min		
Moment obrotowy				6500 N	
Regulowana prędkość				0 - 8,7 mm/s	
Pojemność				310 ml	
Tuner					DAB+ / FM
Wejście zewnętrzne					Bluetooth 5.0, aux IN jack 3,5 mm
Moc					2 x 15 W
Wyświetlacz					kolorowy 2,4"
Zasilacz					adapter 230 V, bateria Li-ion FESTA share 20 V
Pamięci					30 (DAB+), 30 (FM)
Odporność na wnikanie wody					IPX54
Waga		3 kg	3 kg	1,7 kg	1,3kg
Woltaż	20 V	20 V	20 V	20 V	20 V
Zawartość paczki	kompresor, zasilacz z akumulatorem samochodowego, 3x adaptory do pompowania	wibrator do płytek, akumulator 2,0 Ah, ładowarka, sprawa	wibrator do płytek, sprawa	pistolet do uszczelniania	radio, adapter 230 V



NUMER KATALOGOWY PRODUKTU	28221	28225	28220	28230	28210	28215
Nazwa	wiertarka udarowa SDS MAX	wiertarka udarowa SDS+	wiertarka udarowa	piła tarczowa	szlifierka kątowa	szlifierka kątowa
Moc	1 500 W	1 500 W	800 W	1 400 W	900 W	2 400 W
Prędkość	0 - 520 min-1	0 - 850 min-1	0 - 1 350 min-1	0 - 4 500 min-1	0 - 11 000 min-1	0 - 6 600 min-1
BMP	0 - 4 100	0 - 4 500	0 - 5 500			
Uderzenie	12 J	6 J	2,8 J			
Uchwyt	SDS MAX	SDS+	SDS+ ø 2 - 13 mm	20 mm	M14 / 22,2 mm	M14 / 22,2 mm
Regulowany kąt cięcia				0 - 45°		
Głębokość cięcia 45°				42 mm		
Głębokość cięcia 90°				63 mm		
Max. Średnica koła				185 mm	125 mm	230 mm
Waga	6,8 kg	5 kg	3,2 kg	4,3 kg	2 kg	5,8 kg
Kabel zasilający	3 m guma	2 m guma	2 m guma	2 m plastikowy	2 m guma	2 m guma
Zawartość paczki	wiertarka udarowa, uchwyt boczny, wskaźnik głębokości, klucz, plastikowa obudowa, zapasowe szczotki węglowe, akcesoria SDS MAX: ø 16 x 280 mm 18 x 320 mm	wiertarka udarowa, uchwyt boczny, wskaźnik głębokości, klucz, plastikowa obudowa, zapasowe szczotki węglowe, akcesoria SDS+: ø 8, 10, 12 x 160 mm 20 x 250 mm 14 x 250 mm	wiertarka udarowa, uchwyt boczny, wskaźnik głębokości, uchwyt ø 2 - 13 mm, plastikowa obudowa, wazelina, zapasowe szczotki węglowe, akcesoria SDS+: ø 6, 8, 10 x 160 mm 20 x 250 mm 14 x 250 mm	Piła tarczowa, przewodnik boczny, klucz, zapasowe szczotki węglowe, brzeszczot ø 185 x 2,3/1,3 x 20 mm 24T	szlifierka kątowa, osłona ochronna, uchwyt boczny, klucz, zapasowe szczotki węglowe	szlifierka kątowa, osłona ochronna, uchwyt boczny, klucz, zapasowe szczotki węglowe

NEW

prędkość
1000 - 1850 min⁻¹

długość
110 - 180 cm

moc
750 W

średnica
koła
Ø 225 mm



ergonomiczny gumowany uchwyt dla wygodnego i bezpiecznego chwytu



FESTA
POWER X TOOLS

SZLIFIERKA DO PŁYT KARTONOWO-GIPSOWYCH

230V ~ 50Hz	750W	1000-1850min ⁻¹	Ø 225mm	110-180 cm
LED	4m	DRYWALL		



N.p.
28240

specyfikacja

1

NEW



FESTA
POWER X TOOLS

ODKURZACZ 30L

230 V ~50 Hz | 1600 W | MAX 2000W | 82dB | IPX4 | 3m | 5m

30L | WET DRY | AUTO ON-OFF | AUTOMATIC FILTER CLEANING | HEPA

N.p.	specyfikacja	
28345		1
28346	Filtr HEPA	1

NEW



WEST BERG

ODKURZACZ 30L

230 V ~50 Hz | 1200 W | 3m | 5m | SEMI-AUTOMATIC FILTER CLEANING

30L | WET DRY | AUTO ON-OFF | SEMI-AUTOMATIC FILTER CLEANING | HEPA

N.p.	specyfikacja	
28340		1
28342	Filtr HEPA	1

FESTA
 POWER X TOOLS

**MIESZALNIK ELEKTRYCZNY DO
 MIESZANEK BUDOWLANYCH**

Wejście	1800 W
Napięcie/częstotliwość	230 V / 50 Hz
Koła zębate	2
1. bieg (bieg jałowy)	0 - 450 ot./min.
2. bieg (bieg jałowy)	0 - 790 ot./min.
Ochrona przed przeładowaniem	Tak
Średnica kosza do mieszania	100 mm
Długość łopatki	570 mm
Waga	5,6 kg

Zn **CE**

N.p.	specyfikacja	
35311	mieszadło	1
35318	zapasowy węgiel	1
35319	zapasowe mieszadła - para (L+R)	1

FESTA
 POWER X TOOLS

MIESZADŁO DO MATERIAŁÓW BUDOWLANYCH, 1600W

Pobór mocy	1600 W
Napięcie/częstotliwość	230 V / 50 Hz
Stopnie szybkości	2
1. stopień (wolne obroty)	0 - 480 ot./min.
2. stopień (wolne obroty)	0 - 800 ot./min.
Zabezpieczenie przed przeciążeniem	Tak
Gwint łopatki mieszającej	M 14
Średnica kosza mieszającego	140 mm
Długość łopatki	600 mm
Masa	4,7 kg

M14 **Zn** **CE**

N.p.	specyfikacja	
35310		1
35317	zapasowy węgiel	1

FESTA
 POWER X TOOLS

MIESZADŁO DO MATERIAŁÓW BUDOWLANYCH, 850W

Pobór mocy	850 W
Napięcie/częstotliwość	230 V / 50 Hz
Stopnie szybkości	1
1. stopień (wolne obroty)	0 - 500 ot./min.
2. stopień (wolne obroty)	-
Zabezpieczenie przed przeciążeniem	Tak
Gwint łopatki mieszającej	M 14
Średnica kosza mieszającego	120 mm
Długość łopatki	600 mm
Masa	3,7 kg

M14 **Zn** **CE**

N.p.	specyfikacja	
35300		1
35316	zapasowy węgiel	1



NEW

**WEST
BERG****MIESZADŁO DO MATERIAŁÓW BUDOWLANYCH, 1600W**

Pobór mocy	1600 W
Napięcie/częstotliwość	230 V / 50 Hz
Stopnie szybkości	2
1. stopień (wolne obroty)	180 - 400 ot./min.
2. stopień (wolne obroty)	300 - 700 ot./min.
Zabezpieczenie przed przeciążeniem	Tak
Gwint łopatki mieszającej	M 14
Średnica kosza mieszającego	140 mm
Długość łopatki	600 mm
Masa	5,4 kg

M14 Zn CE



N.p. specyfikacja

35305

1

35315 zapasowy węgiel

1



NEW

**FESTA**
POWER X TOOLS**MYJKA
WYSOKOCIŚNIENIOWA**

230 V ~50 Hz	1800 W	IPX5	MAX 7 l/min	MAX 140 bar	MAX 50°C	5m	AUTO STOP	7,8 kg
-----------------	-----------	------	-------------------	-------------------	-------------	----	--------------	-----------

N.p. Specyfikacje

45271



1

**FESTA****MYJKA
WYSOKOCIŚNIENIOWA**

230 V ~50 Hz	1500 W	MAX 120 bar	MAX 6 l/min	IPX5	5m	AUTO STOP
-----------------	-----------	-------------------	-------------------	------	----	--------------

N.p. specyfikacja

45270 myjka wysokociśnieniowa



1



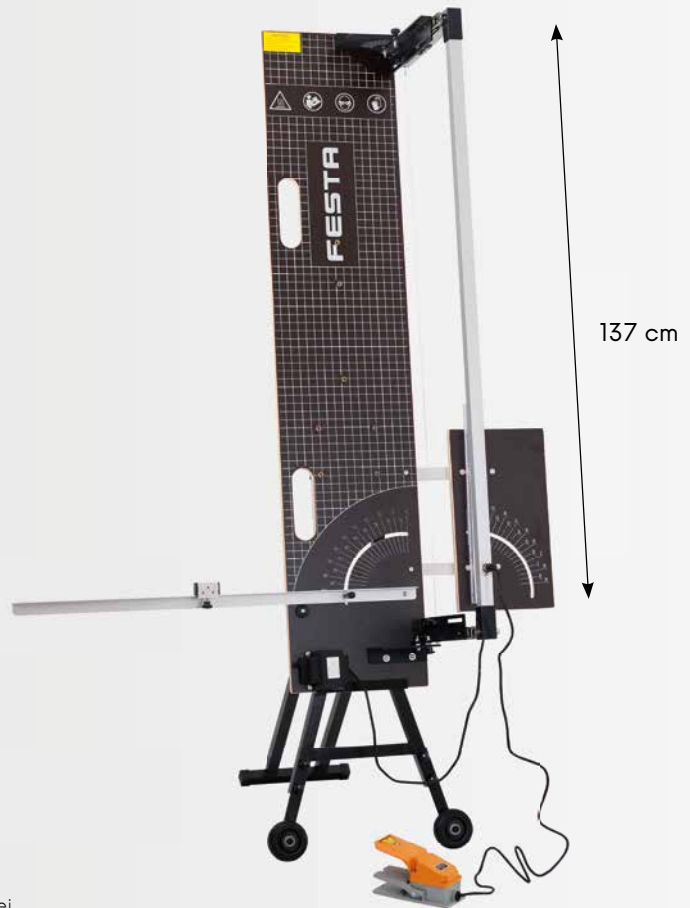
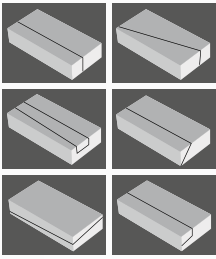

NÓŻ DO STYROPIANU

- Napięcie / częstotliwość **230 V/50 Hz**
- Pobór energii **200 W**
- Długość cięcia **137 cm**
- Wysokość cięcia **35 cm**
- Ochrona **IP44**
- Kąt cięcia **0° - 90°**

· sprzęt: stojak, włącznik nożny, Ni-Cr drut tnący, czyszczenie szczotki mosiężnej, narzędzia, złącza, walizka z kółkami



N.p. Specyfikacja

35348



1

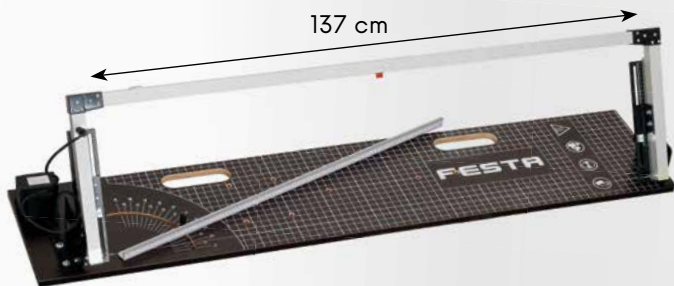
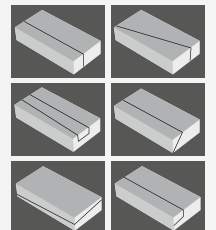
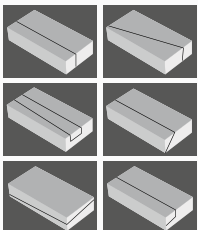

NÓŻ DO STYROPIANU

- Napięcie / częstotliwość **230 V / 50 Hz**
- Pobór energii **200 W**
- Długość cięcia **137 cm**
- Wysokość cięcia **35 cm**
- Ochrona **IP44**
- Kąt cięcia **0° - 90°**

· sprzęt: Ni-Cr drut tnący, czyszczenie szczotki mosiężnej, inbus



Nu. specyfikacja

35345



1



NÓŻ DO STYROPIANU

- Napięcie / częstotliwość **230 V / 50 Hz**
- Pobór energii **160 W**
- Długość cięcia **120 cm**
- Wysokość cięcia **35 cm**
- Ochrona **IP44**
- Kąt cięcia **0° - 90°**

· sprzęt: Ni-Cr drut tnący, czyszczenie szczotki mosiężnej, inbus



Nu. specyfikacja

35330



1



FESTA

NÓZ DO STYROPIANU

- Napięcie / częstotliwość: 230 V / 50 Hz
- Pobór energii: 160 W
- Długość cięcia: 120 cm
- Wysokość cięcia: 52 cm
- Ochrona: IP44
- Kąt cięcia: 0° - 90°



· sprzęt: Ni-Cr drut tnący, czyszczenie szczotki mosiężnej, inbus

Nu.	specyfikacja	
35344		1



FESTA

WTĄCZNIK NOŻNY DO PRZECINARKI DO STYROPIANU

· for | for 35330, 35345, 35348



N.p.	Specyfikacja	
35334		1



FESTA

STOJAK NA PRZECINARKĘ DO STYROPIANU

· for | for 35330, 35345, 35348



N.p.	Specyfikacja	
35336		1



FESTA

ZAPASOWA SPRĘŻYNA

· for | for 35330, 35345, 35348



N.p.	Specyfikacja	
35332		1



FESTA

ZAPASOWY ZASILACZ DO PRZECINARKI DO STYROPIANU

· dla 35330, 35345, 35348



napięcie / częstotliwość:	230 V / 50Hz
wyjście:	36 V / 5 A
moc:	200 W



N.p.	Specyfikacja	
35347		1



FESTA

UCHWYT RUSZTOWANIA

· for | for 35330, 35345, 35348



N.p.	Specyfikacja	
35333		1



ZAPASOWY DRUT DO CIĘCIA CR-NI DO PRZECINARKI DO STYROPIANU



N.p.	Specyfikacja	
35346	117 cm	1
35346	137 cm	1



Li-ion
technology

FESTA
POWER X TOOLS

AKUMULATOROWA PRZECINARKA DO STYROPIANU

- bateria **36 V, 1,5Ah Li-ion**
- Pobór energii **180 W**
- Temperatura **max 350 C°**
- Długość noża **20 cm**
- wyposażenie: 2 akumulatory, ładowarka, ostrze, mosiężna szczotka do czyszczenia, imbus



N.p.	specyfikacja	
35323	przecinarka do styropianu	1
35328	zapasowy nóż - długość 14 cm	1
35329	zapasowy nóż - długość 25 cm	1



FESTA
POWER X TOOLS

PRZECINARKA DO STYROPIANU

- Napięcie / częstotliwość **230 V/50 Hz**
- Pobór energii **250 W**
- Temperatura **50-600 C°**
- Długość noża **25 cm**
- Długość kabla zasilającego **3 m**



- sprzęt: czyszczenie szczotki mosiężnej, imbus, ostrze 25 a 30 cm

N.p.	specyfikacja	
35326	przecinarka do styropianu	1
35328	zapasowy nóż - długość 14 cm	1
35329	zapasowy nóż - długość 25 cm	1



FREZ DO PŁYT KANAŁOWYCH

N.p.	specyfikacja	
35327	przewodnica do cięcia polistyrenu	1
35335	zapasowy nóż - długość 30cm	1

FESTA
POWER X TOOLS

PRZECINARKA DO STYROPIANU



- kontrola temperatury

N.p.	specyfikacja	
35325	220 W	1



**FESTA****FALOWNIK SPAWALNICZY TIG/MMA 160 A**

Napięcie częstotliwość:	230 V 50 Hz
Wolne napięcie:	55 V
Prądy spawalnicze w zakresie regulacji:	10 - 160 A
Średnica elektrody:	1,5 - 4,0 mm
Cykl roboczy:	TIG- 160 A 60%, MMA - 140 A 60%
Klasa ochrony:	IP 21
Rodzaj spawania:	TIG/MMA
Wymiary:	405 x 165 x 270 mm
Technologia:	Anti-stick, Arc-force, Hot start, Lift TIG
waga:	6 kg



N.p. specyfikacja

70040 Falownik spawalniczy TIG/MMA 160A



1

FESTA

LCD display

FESTA**PRZYŁBICA ŚCIEMNIAJĄCA – AUTOMAT**

pole widzenia	98 x 80 mm
prędkość ściemniania filtra	1/25 000 s
ściemnianie filtra	DIN 5-8 / 9-13
Ochrona przed promieniowaniem UV / IR UV / IR	DIN 16
klasa optyczna	1 1 1 2
liczba czujników	4
zasilacz	Ogniwo słoneczne + bateria CR2450
tryb pracy	Spawanie, szlifowanie

CE EN 379

N.p. specyfikacja

70064 aktywny



1

70066 wymienna szybka ochronna

1



**FESTA**

PRZYŁBICA ŚCIEMNIAJĄCA AUTOMAT, KARBON



N.p.	specyfikacja	
70063	aktywny	4



PRZYŁBICA ŚCIEMNIAJĄCA AUTOMAT



N.p.	specyfikacja	
70060	aktywny	4



PRZYŁBICA ŚCIEMNIAJĄCA AUTOMAT



N.p.	specyfikacja	
70061		4



SZKIEŁKO DO MASKI SPAWALNICZEJ

2x

N.p.	specyfikacja	
70065	113 x 80 mm	20



OKULARY DO SPAWANIA

UV-IR protection

N.p.	specyfikacja	
70062		1



ELEKTRODA RUTYLOWA ER 117

· certyfikowany

N.p.	specyfikacja	mnożství	
70021	Ø 2,0 x 300 mm	10 szt.	1
70020	Ø 2,0 x 300 mm	2,5 kg	8
70026	Ø 2,5 x 300 mm	10 szt.	1
70025	Ø 2,5 x 300 mm	2,5 kg	8
70033	Ø 3,2 x 350 mm	10 szt.	1
70032	Ø 3,2 x 350 mm	5 kg	4

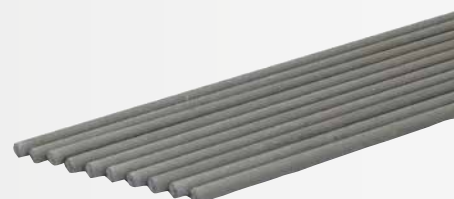

ELEKTRODA SPAWALNICZA

· certyfikowany

N.p.	specyfikacja	mnożství	
70030	Ø 2,0 x 300 mm	2,5 kg	1
70031	Ø 2,0 x 300 mm	5 kg	1
70035	Ø 2,5 x 300 mm	2,5 kg	8
70036	Ø 2,5 x 300 mm	10 szt.	1
70037	Ø 3,2 x 350 mm	5 kg	5



MŁOTEK SPAWALNICZY



N.p.	specyfikacja	
19115	320 g	1



UCHWYT ELEKTRODY



N.p.	specyfikacja	
70070	300 A	1



UCHWYT MASY



N.p.	specyfikacja	
70075	300 A	1



FESTA

MAGNES KĄTOWY



N.p.	specyfikacja	ładowność	
70096	150 x 130 x 30 mm · 45°, 90°, 135°	25 kg	10



MAGNES KĄTOWY



N.p.	specyfikacja	ładowność	
70090	85 x 85 mm · 45°, 90°	9 kg	10



MAGNES KĄTOWY



N.p.	specyfikacja	ładowność	
70093	95 x 64 mm · 30°, 45°, 60°, 75°, 90°	9 kg	10
70094	120 x 90 mm · 30°, 45°, 60°, 75°, 90°	18 kg	10
70095	137 x 110 mm · 30°, 45°, 60°, 75°, 90°	27 kg	10



MAGNES KĄTOWY



N.p.	specyfikacja	ładowność	
70091	95 x 109 x 25 mm · 45°, 90°, 135°	13 kg	10
70092	130 x 150 x 32 mm · 45°, 90°, 135°	22 kg	5



FESTA
POWER X TOOLS

SPAWARKA DO RUR

Napięcie / częstotliwość 230 V / 50 Hz
 Pobór energii 750 / 1500 W
 Temperatura 0-300 C°
 Rozszerzenia Ø 20,25,32,40,50,63 mm
 Waga 1,6 kg



· sprzęt: miernik, poziomica, śrubokręt, klucz inbusowy, nożyce do rur, 4 x adapter spawalniczy

N.p.	
17182	1

FESTA
POWER X TOOLS

SPAWARKA DO RUR

Napięcie / częstotliwość 230 V / 50 Hz
 Pobór energii 800 / 1000 W
 Temperatura 0-300 C°
 Rozszerzenia Ø 16, 20, 25, 32 mm
 Waga 1 kg



· sprzęt: klucz inbusowy, 4 x adapter spawalniczy

N.p.	
17183	1

FESTA**KOMPRESOR 6 L - BEZOŁOWIOWY**

Zasilacz	230 V 50Hz
Wydajność	1,2 kW (1,5HP)
Pojemność przechowywania	6 l
Max. nacisk	8 Bar
Prędkość	3900 min.
Suction power	180 l/min.
Wypełnianie wydajności	116 l/min.
Waga	10 kg

N.p.
35360**KOMPRESOR 24 L
BEZOŁOWIOWY**

Wydajność	1100 W
Zasilacz	230 V 50Hz
Uruchom bez obciążenia	2850 min-1
Max. nacisk	8 bar
Free Air Intake	160 l min
Rodzaj	bezołojowy bez ulja
Pojemność przechowywania	24 L
Waga	23 kg

N.p. specyfikacja
35361 1,1 kW, 24 l**KOMPRESOR 24 L**

Wydajność	1500 W
Zasilacz	230 V 50Hz
Uruchom bez obciążenia	2850 min-1
Max. nacisk	8 bar
Free Air Intake	200 l min
Rodzaj	olejowy oljassav
Pojemność przechowywania	24 L
Waga	24 kg

N.p. specyfikacja
35362 1,5 kW, 24 l

500 ml



600 ml

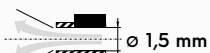
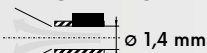

1000 ml

FESTA**PISTOLET
DO MYCIA**N.p. specyfikacja
48020 górny**FESTA****PISTOLET
DO MYCIA**N.p. specyfikacja
48021 górny
48047 dysza Ø 1,7 mm**FESTA****PISTOLET
DO MYCIA**N.p. specyfikacja
48022 górny
48046 dysza Ø 1,5 mm

FESTA

PISTOLET DO PRZEDMUCHIWANIA

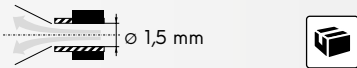

N.p. specyfikacja
48030 dolni 1



PISTOLET NATRYSKOWY DO FARB I TYNKÓW

- 4 - 6 Bar
- 5 l
- dysza Ø 4; 6; 8 mm

N.p. specyfikacja
48037 1



FESTA

PISTOLET DO PRZEDMUCHIWANIA

- 25 mm
- 90 mm
- 190 mm

N.p. specyfikacja
48004 10



FESTA

PISTOLET DO PRZEDMUCHIWANIA

N.p. specyfikacja
48005 krótki 25



FESTA

PISTOLET DO PRZEDMUCHIWANIA

N.p. specyfikacja
48006 średni 25



FESTA

PISTOLET DO PRZEDMUCHIWANIA

N.p. specyfikacja
48007 długie 25



FESTA

PISTOLET DO MYCIA DOLNY

N.p. specyfikacja
48015 spodni 1



FESTA

PISTOLET DO ZABEZPIECZEŃ ANTYKOROZYJNYCH

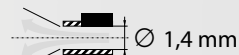

N.p. specyfikacja
48036 spodni 1





30 cm

FESTA

PISTOLET DO POMPOWANIA Z MANOMETREM

- 0 - 10 bar
- LCD display
- bar, kPa, Psi, kgf/cm²

2x AAA

N.p.	specyfikacja	
48011	0 - 10 bar	10



FESTA

PISTOLET DO POMPOWANIA Z MANOMETREM

N.p.	specyfikacja	
48010		1



FESTA

ZESTAW DO KOMPRESORA

5x

- 1. pistolet z dolnym zbiornikiem
- 2. pistolet do pompowania z manometrem
- 3. pistolet do mycia
- 4. pistolet do przedmuchiwania
- 5. spiralny wąż ze złączkami

N.p.	specyfikacja	
48001		1



FESTA

ZESTAW DO KOMPRESORA

3x

- 1. pistolet do pompowania z manometrem
- 2. pistolet do przedmuchiwania
- 3. spiralny wąż ze złączkami

N.p.	specyfikacja	
48002		1

NEW

ADAPTERY DO KOMPRESORÓW

8x

N.p.	specyfikacja	
48013		1



FESTA

SPIRALNY WĄŻ ZE ZŁĄCZKAMI

N.p.	specyfikacja	
48043	5 m 8 atm ø 10 mm	1



FESTA

SPIRALNY WĄŻ ZE ZŁĄCZKAMI

N.p.	specyfikacja	
48040	5 m 8 atm ø 8 mm	1
48041	10 m 8 atm ø 8 mm	1
48042	15 m 8 atm ø 8 mm	1



FESTA

SPIRALNY WĄŻ ZE ZŁĄCZKAMI max. 20 Bar

N.p.	specyfikacja	
48031	5 m ø 9/15 mm	1
48032	10 m ø 9/15 mm	1
48033	15 m ø 9/15 mm	1
48034	20 m ø 9/15 mm	1

FESTA

FILTR

· maksymalne ciśnienie **10 bar**



N.p.	specyfikacja	
48008	G 1/4'	1

FESTA

REGULATOR CIŚNIENIA Z MANOMETREM

· ciśnienie robocze **0 - 10 bar**



N.p.	specyfikacja	
48009	G 1/4'	1

FESTA

ZAMIENNE DYSZE

· dla **48021**



N.p.	specyfikacja	
48047	dysza Ø 1,7 mm	1

FESTA

ZAMIENNE DYSZE

· dla **48022**



N.p.	specyfikacja	
48046	dysza Ø 1,5 mm	1

TABELA ROZMIARÓW GWINTÓW RUROWYCH WHITWORTH

ROZMIAR GWINTU G W CALACH	MAKSYMALNY ZEW Ø WĄTEK - MM
1/8	9,728
1/4	13,157
3/8	16,662
1/2	20,955
3/4	26,441
1	33,249

ZŁĄCZKA ŻEŃSKA

N.p.	specyfikacja	
48075	1/4' zew	10
48076	3/8' zew	10
48077	1/2' zew	10
48095	1/4' wew	10
48096	3/8' wew	10
48097	1/2' wew	10

ŁĄCZNIK MOSIĄDZ

N.p.	specyfikacja	
48050	połączenie 1/4' zew x 1/4' zew	10
48051	redukcja 1/4' zew x 3/8' zew	10

REDUKCJA

N.p.	specyfikacja	
48054	3/8' zew x 1/4' wew	10
48055	1/2' zew x 3/8' wew	10
48056	redukcja 3/8' zew x 1/2' wew	10
48057	redukcja 1/4' zew x 3/8' wew	10

ZŁĄCZKA MĘSKA - GW. ZEW MOSIĄDZ

N.p.	specyfikacja	
48080	1/4' zew	10
48081	3/8' zew	10
48090	3/8' wew	10
48091	1/4' wew	10

ZŁĄCZKA MĘSKA - WĄŻ MOSIĄDZ

N.p.	specyfikacja	
48085	1/4' - 6 mm	10
48086	3/8' - 9 mm	10
48087	1/2' - 13 mm	10

ZŁĄCZKA GW. ZEWN - WĄŻ MOSIĄDZ

N.p.	specyfikacja	
48060	Ø 6 mm - 1/8' zew	10
48061	Ø 6 mm - 1/4' zew	10
48062	Ø 6 mm - 3/8' zew	10
48063	Ø 9 mm - 1/4' zew	10
48064	Ø 9 mm - 3/8' zew	10
48065	Ø 13 mm - 1/4' zew	10
48066	Ø 13 mm - 3/8' zew	10
48067	Ø 6 mm - 3/8' wew	10
48068	Ø 9 mm - 3/8' wew	10
48093	Ø 6 mm - 1/4' wew	10
48094	Ø 9 mm - 1/4' wew	10

ZŁĄCZKA ŻEŃSKA - WĄŻ NIKIEL DAMSKA

N.p.	specyfikacja	
48070	1/4' - 6 mm	10
48071	3/8' - 9 mm	10
48072	1/2' - 13 mm	10

· wyświetlacz cyfrowy



FESTA
POWER X TOOLS

PISTOLETY NA GORĄCE POWIETRZE Z REGULACJĄ TEMPERATURY

Napięcie/częstotliwość	230V / 50Hz
Pobór mocy	2000W
położenie przełącznika	0 - I (350°C) - II (550°C)
Akcesoria	nierdzewne przedłużki - 4 szt.

FESTA
POWER X TOOLS

PISTOLETY NA GORĄCE POWIETRZE Z REGULACJĄ TEMPERATURY I PRZEPŁYWU

Napięcie/częstotliwość	230V / 50Hz
Pobór mocy	2000W
położenie przełącznika	0 - I (50°C) - II (50 - 600°C)
przepływ powietrza	120 - 500 l/min.
Akcesoria	nierdzewne przedłużki - 4 szt.



N.p. specyfikacja
35320 2000 W



1



N.p. specyfikacja
35322 2000 W



1

NEW



NEW



WEST BERG

LUTOWNICA TRANSFORMATOROWA

230V
~ 50Hz **175W**

N.p. specyfikacja

28275 1
28278 groty lutownicze 3 szt.



1

WEST BERG

LUTOWNICA OPOROWA

230V
~ 50Hz **60W**

N.p. specyfikacja

28280 1
28282 groty lutownicze 2 szt.



1

FESTA
 POWER X TOOLS

**PISTOLET DO KLEJENIA NA GORĄCO
 BEZPRZEWODOWY**

· Ø laski klej 11,2 mm

230V
 ~ 50Hz

80W

N.p. specyfikacja

89975

20

NEW

FESTA
 POWER X TOOLS

**PISTOLET
 DO KLEJENIA NA GORĄCO**

· Ø laski klej 7,2 mm

230V
 ~ 50Hz

12W

N.p. specyfikacja

89775

1

**PISTOLET
 DO KLEJENIA NA GORĄCO**

· Ø laski klej 7,2 mm

230V
 ~ 50Hz

15W

N.p. specyfikacja

89970

25

**PISTOLET
 DO KLEJENIA NA GORĄCO**

· Ø laski klej 11,2 mm

230V
 ~ 50Hz

60W

N.p. specyfikacja

89973

20

LASKI KLEJ

N.p.	Ø	długość		
89980	7,2 mm	100 mm	12 szt.	100
89988	7,2 mm	100 mm	1 kg	25

LASKI KLEJ

N.p.	Ø	długość		
89985	11,2 mm	200 mm	10 szt.	50
89987	11,2 mm	200 mm	1 kg	25

LASKI KLEJ

N.p.	Ø	długość		
89989	7,2 mm	100 mm	12 szt.	100
89990	11,2 mm	200 mm	10 szt.	50



GRZEJNIK ELEKTRYCZNY

Napięcie	230V ~50Hz
Wydajność	3300W
Prąd znamionowy	14.5A
Ustawienie mocy	30/1650/3300W
Zakres temperatury	5-40°C
Pokrycie	IP24
Wymiary	27 x 25.5 x 40cm
Masa	4.8 kg

- Szybkie i wydajne ogrzewanie piwnic, warsztatów, sklepów, namiotów imprezowych, szklarni itp.
- Nie zużywa tlenu
- Bezpieczna praca, bezstopniowa regulacja mocy, termostat pokojowy, wentylator
- Element grzewczy ze stali nierdzewnej
- Możliwość łatwego użytkownika do wentylacji bez ogrzewania
- Niski poziom hałasu
- Wysokiej jakości opracowanie, materiały, wytrzymała konstrukcja stalowa, łatwa i bezpieczna obsługa, długa żywotność



N.p. specyfikacja
35833 3,3 kW



1

GRZEJNIK GAZOWY

Gaz	G30-I3B/P
Cisnienie gazu	0.7bar
Napięcie znamionowe	230V 50Hz
Moc silnika	25W
Maksymalne zużycie gazu	1.11 kg/h
Maksymalne wydajność cieplna	15kW
Maksymalne objętość gorącego powietrza	300m ³ /h

- Szybkie i wydajne ogrzewanie podczas prac budowlanych, w warsztatach itp.
- Zużywa tlen!
- bezpośrednie nagrzewanie powietrza z wymuszonym obiegiem - szybkie dostarczanie ciepła
- Bezpieczna praca, ciągła regulacja mocy
- Termostat i zawór bezpieczeństwa zapobiegający przegrzaniu i wyciekowi gazu
- W zestawie akcesoria - regulator i wąż doprowadzający gaz
- wysoka jakość opracowania, materiały, solidna konstrukcja stalowa, łatwe i bezpieczne obsługa, długa żywotność



N.p. specyfikacja
35845 15 kW



1



GRZEJNIK GAZOWY

Gaz	G30-i3b/p
Cisnienie gazu	1.5bar
Napięcie znamionowe	230V 50Hz
Moc silnika	70W
Maksymalne zużycie gazu	2.2kg/h
Maksymalne wydajność cieplna	30kW
Maksymalne objętość gorącego powietrza	750m ³ /h

- Szybkie i wydajne ogrzewanie podczas prac budowlanych, w warsztatach itp.
- Zużywa tlen!
- bezpośrednie nagrzewanie powietrza z wymuszonym obiegiem - szybkie dostarczanie ciepła
- Bezpieczna praca, ciągła regulacja mocy
- Termostat i zawór bezpieczeństwa zapobiegający przegrzaniu i wyciekowi gazu
- W zestawie akcesoria - regulator i wąż doprowadzający gaz
- wysoka jakość opracowania, materiały, solidna konstrukcja stalowa, łatwe i bezpieczne obsługa, długa żywotność



N.p. specyfikacja
35850 30 kW



1



**FESTA****LED LAMPA**

N.p.	specyfikacja	
37611		1

**FESTA****LED LAMPA ZE STOJAKIEM**

· maszt, ymalna wysokość 180 cm

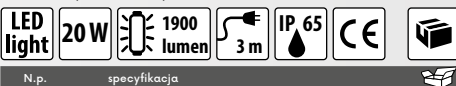

N.p.	specyfikacja	
37615	20 W	1
37616	2 x 20 W	1

**NEW****FESTA**
INDUSTRY**PRZEDŁUŻACZ Z BĘBNEM**

- rubber - IP44
- H07RN-F3G - 2,5mm²
- Wyposażony w bezpiecznik termiczny
- 16 A max. / 3680 W max.
- 4 gniazdka

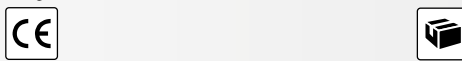

N.p.	specyfikacja	
37740	długość 25 m, 2,5 mm ²	2
37741	długość 50 m, 2,5 mm ²	2

NEW**FESTA**
INDUSTRY**PRZEDŁUŻACZ Z BĘBNEM**

- rubber - IP44
- H05RR-F3G - 1,5mm²
- Wyposażony w bezpiecznik termiczny
- 16 A max. / 3680 W max.
- 4 gniazdka

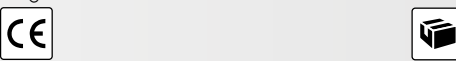

N.p.	specyfikacja	
37750	długość 25 m, 1,5 mm ²	2
37751	długość 50 m, 1,5 mm ²	2

FESTA**PRZEDŁUŻACZ Z BĘBNEM**

- IP20
- H05VV - F 3G 1,5mm², -
- Wyposażony w bezpiecznik termiczny
- Moc w stanie nawiniętym: 1000 W max.
- Moc w stanie rozwiniętym : 3000 W max.
- 4 gniazdka



N.p.	specyfikacja	
37760	długość 25 m, 1,5 mm ²	2
37761	długość 50 m, 1,5 mm ²	2

FESTA
INDUSTRY**PRZEDŁUŻACZ**

- rubber - IP44
- H07RN-F3G - 1,5mm²
- 16 A max. / 3680 W max.



N.p.	specyfikacja	
37744	długość 5 m, 1,5 mm ²	8
37745	długość 10 m, 1,5 mm ²	4
37746	długość 20 m, 1,5 mm ²	8
37747	długość 30 m, 1,5 mm ²	8

NEW**FESTA****PRZEDŁUŻACZ**

- IP20
- H05VV-F3G - 1,5mm²
- 16 A max. / 3680 W max.



N.p.	specyfikacja	
37730	długość 10 m, 1,5 mm ²	8
37731	długość 20 m, 1,5 mm ²	4
37732	NEW długość 30 m, 1,5 mm ²	8
37733	NEW długość 40 m, 1,5 mm ²	4





56

WIERTŁA DO METALU



63

WIERTŁA, FREZYA OTWORNICE
DO DREWNA

67

WIERTŁA MURARSKIE,
DŁUTA

71

KORONKI DIAMENTOWE



74

TARCZE DIAMENTOWE



76

TARCZE TNĄCE



80

SZCZOTKA DRUCIANA

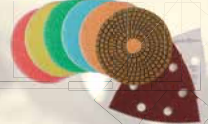

82

ŚCIERNICE LISTKOWE



86

PROFESJONALNE
BRZESZCZOTY

WIERTŁA, CIĘCIE I
NARZĘDZIA WIERTNICZE

54 - 93



FESTA

WIERTŁA DO METALU HSS-G COBALT 5 %

Co 5%, W 6%
Mo 5%, Cr 4%, V 4%

HSS

DIN
338

135°

INOX

1400
MPa

N.p.	specyfikacja		N.p.	specyfikacja		N.p.	specyfikacja	
22510	Ø 1,00 mm	1	22548	Ø 4,80 mm	1	22590	Ø 9,00 mm	1
22515	Ø 1,50 mm	1	22550	Ø 5,00 mm	1	22595	Ø 9,50 mm	1
22520	Ø 2,00 mm	1	22555	Ø 5,50 mm	1	22600	Ø 10,00 mm	1
22525	Ø 2,50 mm	1	22560	Ø 6,00 mm	1	22602	Ø 10,20 mm	1
22530	Ø 3,00 mm	1	22565	Ø 6,50 mm	1	22605	Ø 10,50 mm	1
22532	Ø 3,20 mm	1	22568	Ø 6,80 mm	1	22610	Ø 11,00 mm	1
22535	Ø 3,50 mm	1	22570	Ø 7,00 mm	1	22615	Ø 11,50 mm	1
22540	Ø 4,00 mm	1	22575	Ø 7,50 mm	1	22620	Ø 12,00 mm	1
22542	Ø 4,20 mm	1	22580	Ø 8,00 mm	1	22625	Ø 12,50 mm	1
22545	Ø 4,50 mm	1	22585	Ø 8,50 mm	1	22630	Ø 13,00 mm	1

FESTA

WIERTŁA DO METALU HSS-G W 9 %

W 9%, Mo 3%
Cr 4%, V 1%

HSS

DIN
338

INOX

1100
MPa

MOQ



N.p.	specyfikacja		N.p.	specyfikacja		N.p.	specyfikacja		N.p.	specyfikacja	
19530	Ø 1,00 mm	10	19579	Ø 5,90 mm	5	19612	Ø 9,20 mm	5	19639	Ø 11,90 mm	3
19535	Ø 1,50 mm	10	19580	Ø 6,00 mm	5	19613	Ø 9,30 mm	5	19640	Ø 12,00 mm	3
19536	Ø 1,60 mm	10	19585	Ø 6,50 mm	5	19614	Ø 9,40 mm	5	19641	Ø 12,10 mm	3
19537	Ø 1,70 mm	10	19586	Ø 6,60 mm	5	19615	Ø 9,50 mm	3	19642	Ø 12,20 mm	3
19538	Ø 1,80 mm	10	19587	Ø 6,70 mm	5	19616	Ø 9,60 mm	3	19643	Ø 12,30 mm	3
19539	Ø 1,90 mm	10	19588	Ø 6,80 mm	5	19617	Ø 9,70 mm	3	19644	Ø 12,40 mm	3
19540	Ø 2,00 mm	10	19589	Ø 6,90 mm	5	19618	Ø 9,80 mm	3	19645	Ø 12,50 mm	3
19543	Ø 2,30 mm	10	19590	Ø 7,00 mm	5	19619	Ø 9,90 mm	3	19646	Ø 12,60 mm	1
19544	Ø 2,40 mm	10	19591	Ø 7,10 mm	5	19620	Ø 10,00 mm	3	19647	Ø 12,70 mm	1
19545	Ø 2,50 mm	10	19593	Ø 7,30 mm	5	19621	Ø 10,10 mm	3	19648	Ø 12,80 mm	1
19550	Ø 3,00 mm	10	19594	Ø 7,40 mm	5	19622	Ø 10,20 mm	3	19649	Ø 12,90 mm	1
19552	Ø 3,20 mm	10	19595	Ø 7,50 mm	5	19623	Ø 10,30 mm	3	19650	Ø 13,00 mm	1
19554	Ø 3,40 mm	10	19596	Ø 7,60 mm	5	19624	Ø 10,40 mm	3	19651	Ø 13,20 mm R13	1
19555	Ø 3,50 mm	10	19597	Ø 7,70 mm	5	19625	Ø 10,50 mm	3	19652	Ø 13,50 mm R13	1
19557	Ø 3,70 mm	10	19598	Ø 7,80 mm	5	19626	Ø 10,60 mm	3	19653	Ø 14,00 mm R13	1
19559	Ø 3,90 mm	10	19599	Ø 7,90 mm	5	19627	Ø 10,70 mm	3	19654	Ø 14,50 mm R13	1
19560	Ø 4,00 mm	10	19600	Ø 8,00 mm	5	19628	Ø 10,80 mm	3	19655	Ø 15,00 mm R13	1
19562	Ø 4,20 mm	10	19601	Ø 8,10 mm	5	19629	Ø 10,90 mm	3	19656	Ø 15,50 mm R13	1
19564	Ø 4,40 mm	10	19603	Ø 8,30 mm	5	19630	Ø 11,00 mm	3	19657	Ø 16,00 mm R13	1
19565	Ø 4,50 mm	10	19604	Ø 8,40 mm	5	19631	Ø 11,10 mm	3	19658	Ø 16,50 mm R13	1
19567	Ø 4,70 mm	10	19605	Ø 8,50 mm	5	19632	Ø 11,20 mm	3	19659	Ø 17,00 mm R13	1
19568	Ø 4,80 mm	10	19606	Ø 8,60 mm	5	19633	Ø 11,30 mm	3	19660	Ø 17,50 mm R13	1
19570	Ø 5,00 mm	5	19607	Ø 8,70 mm	5	19634	Ø 11,40 mm	3	19661	Ø 18,00 mm R13	1
19574	Ø 5,40 mm	5	19608	Ø 8,80 mm	5	19635	Ø 11,50 mm	3	19662	Ø 18,50 mm R13	1
19575	Ø 5,50 mm	5	19609	Ø 8,90 mm	5	19636	Ø 11,60 mm	3	19663	Ø 19,00 mm R13	1
19576	Ø 5,60 mm	5	19610	Ø 9,00 mm	5	19637	Ø 11,70 mm	3	19664	Ø 19,50 mm R13	1
19577	Ø 5,70 mm	5	19611	Ø 9,10 mm	5	19638	Ø 11,80 mm	3	19665	Ø 20,00 mm R13	1
19578	Ø 5,80 mm	5									

FESTA

BOX - WIERTŁA DO METALU HSS-G W 9 %

W 9%, Mo 3%
Cr 4%, V 1%

HSS

DIN
338

INOX

1100
MPa

N.p.	specyfikacja	
19669		1
90191	bez wiertel	1



N.p.	specyfikacja		N.p.	specyfikacja	
19530	Ø 1,00 mm	20x	19585	Ø 6,50 mm	15x
19535	Ø 1,50 mm	20x	19590	Ø 7,00 mm	15x
19540	Ø 2,00 mm	20x	19595	Ø 7,50 mm	15x
19545	Ø 2,50 mm	20x	19600	Ø 8,00 mm	15x
19550	Ø 3,00 mm	20x	19605	Ø 8,50 mm	15x
19552	Ø 3,20 mm	20x	19610	Ø 9,00 mm	15x
19555	Ø 3,50 mm	20x	19615	Ø 9,50 mm	15x
19558	Ø 3,80 mm	20x	19620	Ø 10,00 mm	15x
19560	Ø 4,00 mm	30x	19625	Ø 10,50 mm	6x
19562	Ø 4,20 mm	20x	19630	Ø 11,00 mm	6x
19565	Ø 4,50 mm	20x	19635	Ø 11,50 mm	6x
19568	Ø 4,80 mm	20x	19640	Ø 12,00 mm	6x
19570	Ø 5,00 mm	15x	19645	Ø 12,50 mm	6x
19575	Ø 5,50 mm	15x	19650	Ø 13,00 mm	6x
19580	Ø 6,00 mm	30x			

FESTA

WIERTŁA DO METALU HSS 4241

W 4%, Mo 3%
Cr 4%, V 1%

HSS

DIN
338

ALU 900 MPa



MOQ

N.p.	specyfikacja		N.p.	specyfikacja		N.p.	specyfikacja		N.p.	specyfikacja	
19670	Ø 0,6 mm	10	19703	Ø 4,0 mm	10	19736	Ø 7,3 mm	10	19769	Ø 10,6 mm	5
19671	Ø 0,8 mm	10	19704	Ø 4,1 mm	10	19737	Ø 7,4 mm	10	19770	Ø 10,7 mm	5
19672	Ø 0,9 mm	10	19705	Ø 4,2 mm	10	19738	Ø 7,5 mm	10	19771	Ø 10,8 mm	5
19673	Ø 1,0 mm	10	19706	Ø 4,3 mm	10	19739	Ø 7,6 mm	10	19772	Ø 11,0 mm	5
19674	Ø 1,1 mm	10	19707	Ø 4,4 mm	10	19740	Ø 7,7 mm	10	19773	Ø 11,2 mm	5
19675	Ø 1,2 mm	10	19708	Ø 4,5 mm	10	19741	Ø 7,8 mm	10	19774	Ø 11,3 mm	5
19676	Ø 1,3 mm	10	19709	Ø 4,6 mm	10	19742	Ø 7,9 mm	10	19775	Ø 11,4 mm	5
19677	Ø 1,4 mm	10	19710	Ø 4,7 mm	10	19743	Ø 8,0 mm	10	19776	Ø 11,5 mm	5
19678	Ø 1,5 mm	10	19711	Ø 4,8 mm	10	19744	Ø 8,1 mm	10	19777	Ø 11,6 mm	5
19679	Ø 1,6 mm	10	19712	Ø 4,9 mm	10	19745	Ø 8,2 mm	10	19778	Ø 11,7 mm	5
19680	Ø 1,7 mm	10	19713	Ø 5,0 mm	10	19746	Ø 8,3 mm	10	19779	Ø 11,8 mm	5
19681	Ø 1,8 mm	10	19714	Ø 5,1 mm	10	19747	Ø 8,4 mm	10	19780	Ø 11,9 mm	5
19682	Ø 1,9 mm	10	19715	Ø 5,2 mm	10	19748	Ø 8,5 mm	10	19781	Ø 12,0 mm	5
19683	Ø 2,0 mm	10	19716	Ø 5,3 mm	10	19749	Ø 8,6 mm	5	19782	Ø 12,2 mm	5
19684	Ø 2,1 mm	10	19717	Ø 5,4 mm	10	19750	Ø 8,7 mm	5	19783	Ø 12,5 mm	5
19685	Ø 2,2 mm	10	19718	Ø 5,5 mm	10	19751	Ø 8,8 mm	5	19784	Ø 12,8 mm	5
19686	Ø 2,3 mm	10	19719	Ø 5,6 mm	10	19752	Ø 8,9 mm	5	19785	Ø 12,9 mm	5
19687	Ø 2,4 mm	10	19720	Ø 5,7 mm	10	19753	Ø 9,0 mm	5	19786	Ø 13,0 mm	5
19688	Ø 2,5 mm	10	19721	Ø 5,8 mm	10	19754	Ø 9,1 mm	5	19787	Ø 13,2 mm R13	5
19689	Ø 2,6 mm	10	19722	Ø 5,9 mm	10	19755	Ø 9,2 mm	5	19788	Ø 13,5 mm R13	5
19690	Ø 2,7 mm	10	19723	Ø 6,0 mm	10	19756	Ø 9,3 mm	5	19789	Ø 14,0 mm R13	5
19691	Ø 2,8 mm	10	19724	Ø 6,1 mm	10	19757	Ø 9,4 mm	5	19790	Ø 14,5 mm R13	5
19692	Ø 2,9 mm	10	19725	Ø 6,2 mm	10	19758	Ø 9,5 mm	5	19791	Ø 15,0 mm R13	5
19693	Ø 3,0 mm	10	19726	Ø 6,3 mm	10	19759	Ø 9,6 mm	5	19792	Ø 15,5 mm R13	5
19694	Ø 3,1 mm	10	19727	Ø 6,4 mm	10	19760	Ø 9,7 mm	5	19793	Ø 16,0 mm R13	5
19695	Ø 3,2 mm	10	19728	Ø 6,5 mm	10	19761	Ø 9,8 mm	5	19794	Ø 16,5 mm R13	5
19696	Ø 3,3 mm	10	19729	Ø 6,6 mm	10	19762	Ø 9,9 mm	5	19795	Ø 17,0 mm R13	5
19697	Ø 3,4 mm	10	19730	Ø 6,7 mm	10	19763	Ø 10,0 mm	5	19796	Ø 17,5 mm R13	5
19698	Ø 3,5 mm	10	19731	Ø 6,8 mm	10	19764	Ø 10,1 mm	5	19797	Ø 18,0 mm R13	5
19699	Ø 3,6 mm	10	19732	Ø 6,9 mm	10	19765	Ø 10,2 mm	5	19798	Ø 18,5 mm R13	5
19700	Ø 3,7 mm	10	19733	Ø 7,0 mm	10	19766	Ø 10,3 mm	5	19799	Ø 19,0 mm R13	5
19701	Ø 3,8 mm	10	19734	Ø 7,1 mm	10	19767	Ø 10,4 mm	5	19800	Ø 19,5 mm R13	5
19702	Ø 3,9 mm	10	19735	Ø 7,2 mm	10	19768	Ø 10,5 mm	5	19801	Ø 20,0 mm R13	5

FESTA

BOX - WIERTŁA DO METALU HSS 4241

W 4%, Mo 3%
Cr 4%, V 1%

HSS

DIN
338

ALU 900 MPa



N.p.	specyfikacja	
19802		1
90192	bez wiertel	1

N.p.	specyfikacja		N.p.	specyfikacja	
19673	Ø 1,00 mm	20x	19728	Ø 6,50 mm	20x
19678	Ø 1,50 mm	20x	19733	Ø 7,00 mm	10x
19683	Ø 2,00 mm	20x	19738	Ø 7,50 mm	10x
19688	Ø 2,50 mm	20x	19743	Ø 8,00 mm	10x
19693	Ø 3,00 mm	30x	19748	Ø 8,50 mm	10x
19695	Ø 3,20 mm	30x	19753	Ø 9,00 mm	10x
19698	Ø 3,50 mm	30x	19758	Ø 9,50 mm	10x
19701	Ø 3,80 mm	30x	19763	Ø 10,00 mm	10x
19703	Ø 4,00 mm	30x	19768	Ø 10,50 mm	10x
19705	Ø 4,20 mm	30x	19772	Ø 11,00 mm	10x
19708	Ø 4,50 mm	30x	19776	Ø 11,50 mm	10x
19711	Ø 4,80 mm	30x	19781	Ø 12,00 mm	10x
19713	Ø 5,00 mm	20x	19783	Ø 12,50 mm	10x
19718	Ø 5,50 mm	20x	19786	Ø 13,00 mm	5x
19723	Ø 6,00 mm	20x			

FESTA

WIERTŁA DO METALU HSS

W 4%, Mo 3%
Cr 4%, V 1%

HSS

DIN
340

ALU



MOQ

N.p.	specyfikacja		N.p.	specyfikacja		N.p.	specyfikacja	
20220	Ø 2,0 mm x 85 mm	1	20245	Ø 4,5 mm x 126 mm	1	20280	Ø 8,0 mm x 165 mm	1
20225	Ø 2,5 mm x 95 mm	1	20250	Ø 5,0 mm x 132 mm	1	20290	Ø 9,0 mm x 175 mm	1
20230	Ø 3,0 mm x 100 mm	1	20255	Ø 5,5 mm x 139 mm	1	20296	Ø 10,0 mm x 184 mm	1
20235	Ø 3,5 mm x 110 mm	1	20260	Ø 6,0 mm x 139 mm	1			
20240	Ø 4,0 mm x 119 mm	1	20270	Ø 7,0 mm x 156 mm	1			

WIERTŁA DO METALU HSS TITAN

powierzchnia z tytanu dla zwiększenia wydajności i trwałości

TiN **HSS** **DIN 338**



N.p.	specyfikacja	
20400	Ø 1,0 mm	1
20401	Ø 1,5 mm	1
20402	Ø 2,0 mm	1
20403	Ø 2,5 mm	1
20404	Ø 3,0 mm	1
20405	Ø 3,2 mm	1
20406	Ø 3,5 mm	1
20407	Ø 3,8 mm	1
20408	Ø 4,0 mm	1
20409	Ø 4,2 mm	1
20410	Ø 4,5 mm	1

N.p.	specyfikacja	
20411	Ø 4,8 mm	1
20412	Ø 5,0 mm	1
20413	Ø 5,5 mm	1
20414	Ø 6,0 mm	1
20415	Ø 6,5 mm	1
20416	Ø 6,8 mm	1
20417	Ø 7,0 mm	1
20418	Ø 7,5 mm	1
20419	Ø 8,0 mm	1
20420	Ø 8,5 mm	1
20421	Ø 9,0 mm	1

N.p.	specyfikacja	
20422	Ø 9,5 mm	1
20423	Ø 10,0 mm	1
20424	Ø 10,2 mm	1
20425	Ø 10,5 mm	1
20426	Ø 11,0 mm	1
20427	Ø 11,5 mm	1
20428	Ø 12,0 mm	1
20429	Ø 12,5 mm	1
20430	Ø 13,0 mm	1

WIERTŁA DO METALU HSS

HSS **DIN 338**

ALU



N.p.	specyfikacja	
19841	Ø 4,1 mm 5 ks	10
19842	Ø 4,2 mm 5 ks	10
19845	Ø 4,5 mm 5 ks	10
19885	Ø 8,5 mm 1 ks	10
19895	Ø 9,5 mm 1 ks	10



FESTA

HSS-G ZESTAW WIERTEŁ DO METALU

W 9%, Mo 3%
Cr 4%, V 1% **HSS** **DIN 338**

13x



N.p.	specyfikacja	
20333	Ø 1,5 - 6,5 mm	20



FESTA

HSS-G ZESTAW WIERTEŁ DO METALU

W 9%, Mo 3%
Cr 4%, V 1% **HSS** **DIN 338**

19x



N.p.	specyfikacja	
20334	Ø 1,0 - 10,0 mm	20



FESTA

HSS-G ZESTAW WIERTEŁ DO METALU

W 9%, Mo 3%
Cr 4%, V 1% **HSS** **DIN 338**

25x



N.p.	specyfikacja	
20335	Ø 1,0 - 13,0 mm	5



FESTA

ZESTAW WIERTEŁ DO METALU

W 4%, Mo 3%
Cr 4%, V 1% **HSS** **DIN 338**

13x



N.p.	specyfikacja	
20336	Ø 1,5 - 6,5 mm	1



FESTA

ZESTAW WIERTEŁ DO METALU

W 4%, Mo 3%
Cr 4%, V 1% **HSS** **DIN 338**

19x



N.p.	specyfikacja	
20337	Ø 1,0 - 10,0 mm	20



FESTA

ZESTAW WIERTEŁ DO METALU

W 4%, Mo 3%
Cr 4%, V 1% **HSS** **DIN 338**

25x



N.p.	specyfikacja	
20338	Ø 1,0 - 13,0 mm	10

FESTA

ZESTAW WIERTEŁ

TiN



9x

N.p.	specyfikacja
20317	Ø 5-6-8 mm



20



FESTA

ZESTAW WIERTARSKI,
Z ŁBEM
SZEŚCIOKĄTNYM

1/4" HSS



7x

N.p.	specyfikacja
20316	Ø 1,5-2-3-4-5-5,5-6 mm



20



ZESTAW WIERTEŁ DO
METALU

HSS DIN 338



19x

N.p.	specyfikacja
20305	Ø 1,0 - 13,0 mm



25



ZESTAW WIERTEŁ DO
METALU

HSS DIN 338



25x

N.p.	specyfikacja
20311	Ø 1,0 - 13,0 mm



10



ZESTAW WIERTEŁ DO
METALU

HSS DIN 338



13x

N.p.	specyfikacja
20300	Ø 1,5 - 6,5 mm



50



ZESTAW WIERTEŁ DO
METALU

HSS DIN 338



19x

N.p.	specyfikacja
20310	Ø 1 - 13 mm



10



ZESTAW WIERTEŁ

- wiertło do drewna \varnothing 3 · 4 · 5 · 6 · 8 mm
- wiertło do metalu \varnothing 1 · 1,5 · 2 · 2,5 · 3 · 3,5 · 4 · 4,5 · 5 · 5,5 · 6 · 7 · 8 · 10 mm
- wiertło do kamienia \varnothing 4 · 5 · 6 · 8 · 10 mm
- płaskie wiertło do drewna \varnothing 16 · 22 · 25 mm
- otwornica \varnothing 32 · 38 · 44 · 54 mm
- ograniczniki głębokości \varnothing 6 · 8 · 10 mm
- punktak
- miernik średnicy wiertła

- bit 25 mm S 3 · 4 · 4 · 5 · 5 · 6 · 6 · 7
- PH 0 · 0 · 1 · 1 · 2 · 2 · 2 · 3 · 3
- PZ 0 · 0 · 1 · 1 · 2 · 2 · 2 · 3 · 3
- H 2 · 2,5 · 3 · 3,5 · 4 · 5 · 6
- T 10 · 15 · 20 · 25 · 27 · 30 · 40

- bit 50 mm S 4 · 5 · 6 · 6
- PH 1 · 2 · 2 · 3
- PZ 1 · 2 · 2 · 3

- adapter gratownik 4 · 5 · 6 · 7 · 8 · 9 · 10 · 13 mm
- uchwyt na bity

100x

N.p. specyfikacja
20340



1



ZESTAW WIERTEŁ DO METALU

HSS DIN 338



19x

N.p. specyfikacja
20315 \varnothing 1 - 10 mm

10

ZESTAW WIERTEŁ DO METALU

TiN HSS DIN 338



19x

N.p. specyfikacja
20320 \varnothing 1 - 10 x 0,5 mm



30



ZESTAW WIERTEŁ DO METALU

HSS DIN 338



19x

N.p. specyfikacja
20321 \varnothing 1 - 10 x 0,5 mm



5



OSTRZAŁKA WIERTEŁ

N.p. specyfikacja
20380 za \varnothing 3,5 - 10 mm



20

FESTA

OTWORNICE BI - METAL



N.p.	specyfikacja	
24419	\varnothing 19 mm	1
24420	\varnothing 20 mm	1
24422	\varnothing 22 mm	1
24425	\varnothing 25 mm	1
24429	\varnothing 29 mm	1
24432	\varnothing 32 mm	1
24435	\varnothing 35 mm	1
24437	\varnothing 37 mm	1
24444	\varnothing 44 mm	1
24451	\varnothing 51 mm	1
24457	\varnothing 57 mm	1
24464	\varnothing 64 mm	1
24468	NEW \varnothing 68 mm	1
24476	\varnothing 76 mm	1
24483	\varnothing 83 mm	1



FESTA

NOŚNIK DLA HSS OTWORNICE

N.p. specyfikacja
24410 otwornice 14 - 30 mm

14 - 30 mm



1

FESTA

NOŚNIK DLA HSS OTWORNICE

N.p. specyfikacja
24411 otwornice 32 - 152 mm

32 - 152 mm



1

FESTA

ZAPASOWE WIERTŁO DO UCHWYTU OTWORNICY

do 24410, 24411

N.p. specyfikacja
24412



5

FESTA

HSS ZESTAW OTWORNIC, BI – METAL



9x

N.p.	specyfikacja	
24750	Ø 19, 22, 29, 38, 44, 57 mm	10



FESTA

HSS ZESTAW OTWORNIC, BI – METAL



13x

N.p.	specyfikacja	
24751	Ø 19, 22, 29, 35, 38, 44, 51, 57, 64 mm	10



FESTA

WIERTŁO STOPNIOWE TIN

TiN HSS



N.p.	specyfikacja	
20489	Ø 4 - 12 mm 9 krokU 20	
20490	Ø 4 - 20 mm 9 krokU 10	
20491	Ø 5 - 35 mm 13 krokU 10	
20492	Ø 7 - 40,5 mm 13 krokU 5	



FESTA

ZESTAW WIERTEL STOPNIOWYCH

TiN HSS



3x

N.p.	specyfikacja	
20495	Ø 4 - 12, 4 - 20, 4 - 32 mm	1



WIERTŁO STOPNIOWE HSS

HSS



N.p.	specyfikacja	
20487	Ø 4 - 20 mm 9 krokU 10	
20488	Ø 5 - 35 mm 13 krokU 10	
20494	Ø 4 - 32 mm 15 krokU 10	
20493	Ø 7 - 40,5 mm 13 krokU 1	



ZESTAW WIERTEL STOPNIOWYCH

HSS



3x

N.p.	specyfikacja	
20496	Ø 4 - 12, 4 - 20, 4 - 32 mm	1





FESTA

WYKRĘTAKI DO ŚRUB

- Ø 4 mm Ø 11 mm
- Ø 4,5 mm Ø 15 mm
- Ø 6,5 mm Ø 19 mm
- Ø 7,5 mm Ø 24 mm

5x

N.p. specyfikacja
20387 5



FESTA

WYKRĘTAKI DO ŚRUB

- Ø 4 mm
- Ø 4,5 mm
- Ø 6 mm
- Ø 7,5 mm
- Ø 11 mm

5x

N.p. specyfikacja
20386 10



WYKRĘTAKI DO ŚRUB

- Ø 4 mm
- Ø 4,5 mm
- Ø 6 mm
- Ø 7,5 mm
- Ø 11 mm

5x

N.p. specyfikacja
20385 10



POKRĘTŁO DO GWINTOWNIKÓW

N.p. specyfikacja
20397 M3 - M8 10



FESTA

OPRAWKA DO NARZYNEK

DIN 225

N.p. specyfikacja
20396 25 x 9 mm 10



FESTA

POKRĘTŁO DO GWINTOWNIKÓW

DIN 1814

N.p. specyfikacja
20394 M5 - M20 10
20395 1 - 1/2", M3 - M12 10



FESTA

ZESTAW GWINTOWNIKÓW I NARZYNEK

32x

N.p. specyfikacja
20391 M 3, 4, 5, 6, 8, 10, 12 mm 1



FESTA

ZESTAW GWINTOWNIKÓW

21x

N.p. specyfikacja
20390 M 3, 4, 5, 6, 8, 10, 12 mm 1

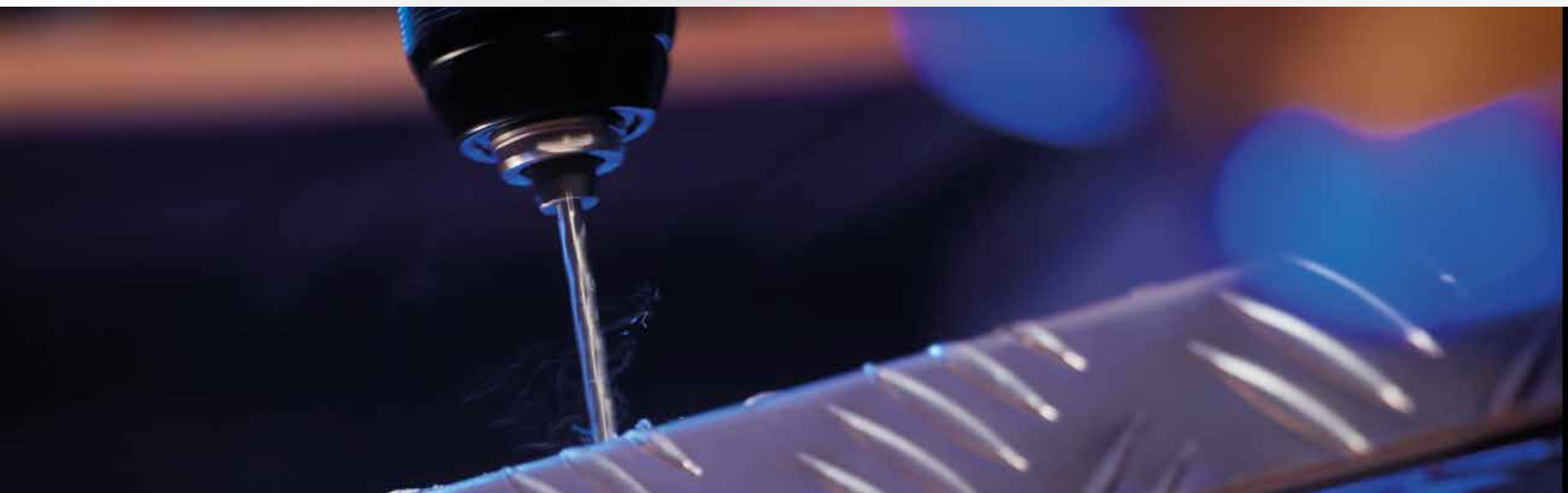

NEW

FESTA

FORSTNER WIERTŁO

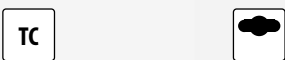

N.p.	specyfikacja	
21531	Ø 15 mm	1
21532	Ø 20 mm	1
21533	Ø 25 mm	1
21534	Ø 30 mm	1
21535	Ø 35 mm	1
21536	Ø 40 mm	1



FESTA



FESTA

ŚWIDRY



N.p.	specyfikacja	
20980	Ø 6 x 230 mm	1
20957	Ø 6 x 300 mm	1
20981	Ø 8 x 230 mm	1
20958	Ø 8 x 300 mm	1
20982	Ø 10 x 230 mm	1
20896	Ø 10 x 300 mm	1
20913	Ø 10 x 450 mm	1
20983	Ø 12 x 230 mm	1
20897	Ø 12 x 300 mm	1
20915	Ø 12 x 450 mm	1
20920	Ø 12 x 600 mm	1
20898	Ø 14 x 300 mm	1
20916	Ø 14 x 450 mm	1
20921	Ø 14 x 600 mm	1

N.p.	specyfikacja	
20984	Ø 16 x 230 mm	1
20899	Ø 16 x 300 mm	1
20917	Ø 16 x 450 mm	1
20922	Ø 16 x 600 mm	1
20918	Ø 18 x 450 mm	1
20923	Ø 18 x 600 mm	1
20919	Ø 20 x 450 mm	1
20924	Ø 20 x 600 mm	1
20724	Ø 22 x 450 mm	1
20725	Ø 24 x 450 mm	1
20726	Ø 26 x 450 mm	1
20727	Ø 28 x 450 mm	1
20728	Ø 30 x 450 mm	1

FESTA

ŚWIDRY – ZESTAW



5x

N.p.	specyfikacja	
20911	Ø 8, 10, 12, 14, 16 x 460 mm	10



FESTA

ŚWIDRY – ZESTAW



6x

N.p.	specyfikacja	
20912	Ø 6, 8, 10, 12, 16, 20 x 230 mm	10



WIERTŁA DO DREWNA



N.p.	specyfikacja	
20729	Ø 6 x 400 mm	1
20731	Ø 8 x 400 mm	1
20736	Ø 8 x 600 mm	1
20730	Ø 10 x 400 mm	1
20737	Ø 10 x 600 mm	1



N.p.	specyfikacja	
20732	Ø 12 x 400 mm	1
20738	Ø 12 x 600 mm	1
20733	Ø 14 x 400 mm	1
20739	Ø 14 x 600 mm	1

N.p.	specyfikacja	
20734	Ø 16 x 400 mm	1
20740	Ø 16 x 600 mm	1
20735	Ø 18 x 400 mm	1
20741	Ø 18 x 600 mm	1

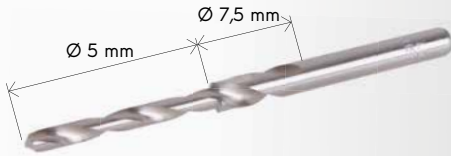

FESTA

CAŁKOWICIE SZLIFOWANE WIERTŁO

HSS

N.p.	specyfikacja	
20210	Ø 7,5, 5 mm	1



ZESTAW WIERTEŁ DO DREWNA



N.p.	specyfikacja	
21440	Ø 4 x 75 mm	1
21441	Ø 5 x 85 mm	1
21442	Ø 6 x 90 mm	1
21443	Ø 7 x 105 mm	1
21444	Ø 8 x 115 mm	1
21445	Ø 9 x 120 mm	1
21446	Ø 10 x 120 mm	1



WIERTŁO FREZ TIN

HSS TiN



N.p.	specyfikacja	
20460	Ø 6 mm	50



ZESTAW WIERTEŁ DO DREWNA



N.p.	specyfikacja	
20910	8 szt. Ø 3, 4, 5, 6, 7, 8, 9, 10 mm	10
20905	5 szt. Ø 4, 5, 6, 8, 10 mm	10



ZESTAW WIERTEŁ PUSZKOWYCH



5x

N.p.	specyfikacja	
21530	Ø 15, 20, 25, 30, 35 mm Ø 8 mm	20



WIERTŁA FREZY ZESTAW

HSS TiN



N.p.	specyfikacja	
20450	Ø 3, 4, 5, 6, 6.5, 8 mm	20

ZESTAW ŁOPATKOWYCH WIERTEŁ DO DREWNA



6x

N.p.	specyfikacja	
20901	Ø 10, 12, 16, 18, 20, 25 mm	20



ZESTAW WIERTEŁ RĘCZNYCH

HOBBY

4x

N.p.	specyfikacja	
20381	Ø 2, 3, 4, 5 mm	20





FESTA

ZESTAW ŁOPATKOWYCH WIERTEŁ DO DREWNA

- Ø 19 mm
- Ø 22 mm
- Ø 25,5 mm
- Ø 36 mm
- Ø 44 mm
- Ø 51 mm
- Ø 60 mm
- Ø 67 mm
- Ø 76 mm
- Ø 82 mm
- inbus
- 2x główka



12x

N.p.	specyfikacja	
24712	6 tpi	20



FESTA

ZESTAW ŁOPATKOWYCH WIERTEŁ DO DREWNA

- Ø 64 mm
- Ø 73 mm
- Ø 89 mm
- Ø 102 mm
- Ø 127 mm
- inbus
- główka



8x

N.p.	specyfikacja	
24706	6 tpi	20



FESTA

KORONKA Z WIERTŁEM REGULOWANY

Ø 19 - 127 mm



N.p.	Specyfikacja	
24415	Ø 19 - 127 mm	max. głęboka 29 mm

FESTA

OTWORNICA DO DREWNA I PŁYT GIPSOWO - KARTONOWYCH



N.p.	specyfikacja	
24715	1' Ø 67 mm	6 tpi
24713	1' Ø 73 mm	6 tpi
24714	1' Ø 102 mm	6 tpi
24720	1' Ø 152 mm	6 tpi



OTWORNICE DO DREWNA



N.p.	specyfikacja	
24721	1' Ø 26, 32, 38, 45, 50, 56, 63 mm	10
24722	2' Ø 26, 32, 38, 45, 50, 56, 63 mm	10

WYCINAK DO PŁYT I SKLEJKI



N.p.	specyfikacja	
24716	Ø 30 - 120 mm	5



FESTA

TARNIK CYLINDRYCZNY

M14



N.p.	specyfikacja	
21807	Ø 30 mm / 60 mm	1

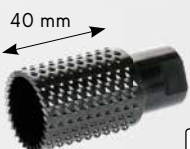

FESTA

TARNIK KULKOWY

M14



N.p.	specyfikacja	
21808	Ø 30 mm / 105 mm	10





ZESTAW KOŃCÓWEK POLERSKICH METALOWYCH

5x

6 mm



N.p. specyfikacja
21541

25



ZESTAW KOŃCÓWEK POLERSKICH

5x

N.p. specyfikacja
21540 Ø 3 mm, 6 mm



12

ZESTAW KOŃCÓWEK POLERSKICH

190x

N.p. specyfikacja
24755



5



ZESTAW KOŃCÓWEK POLERSKICH

150x

N.p. specyfikacja
24756

10



FREZY DO DREWNA



5x

N.p. specyfikacja
21450 Ø 8 mm



10



FREZY DO DREWNA



12x

N.p. specyfikacja
21451 Ø 8 mm



10



FREZY DO DREWNA



24x

N.p. specyfikacja
21452 Ø 8 mm



1

FREZY DO DREWNA



35x

N.p. specyfikacja
21453 Ø 8 mm



1



FREZY DO DREWNA



59x

N.p. specyfikacja
21454 Ø 8 mm



1



FESTA

WIERTŁA WIDIOWE UDAROWE

DIN 8039



podwójne wiertło



N.p.	specyfikacja	A mm	B mm	
20673	Ø 3 mm	60	30	100
20674	Ø 4 mm	75	40	100
20675	Ø 5 mm	85	50	100
20676	Ø 6 mm	100	60	100
20677	Ø 6 mm	200	160	50
20685	Ø 6 mm	300	260	50
20678	Ø 8 mm	120	75	50
20686	Ø 8 mm	200	155	50

N.p.	specyfikacja	A mm	B mm	
20687	Ø 8 mm	300	255	25
20688	Ø 8 mm	400	340	25
20680	Ø 10 mm	120	70	50
20690	Ø 10 mm	200	150	50
20691	Ø 10 mm	300	250	25
20692	Ø 10 mm	400	340	25
20682	Ø 12 mm	150	100	50
20694	Ø 12 mm	300	250	25

N.p.	specyfikacja	A mm	B mm	
20696	Ø 12 mm	400	340	25
20684	Ø 14 mm	150	90	25
	zmniejszenie Ø 10 mm			
20697	Ø 14 mm	300	240	5
	zmniejszenie Ø 10 mm			
20698	Ø 14 mm	400	340	15
	zmniejszenie Ø 10 mm			

FESTA

WIERTŁA WIDIOWE UDAROWE SDS+

SDS+



podwójne wiertło



N.p.	specyfikacja	A mm	B mm	
20855	Ø 14 mm	160	75	

N.p.	specyfikacja	A mm	B mm	
				25

N.p.	specyfikacja	A mm	B mm	
				25

FESTA

WIERTŁA WIDIOWE UDAROWE SDS+

SDS+

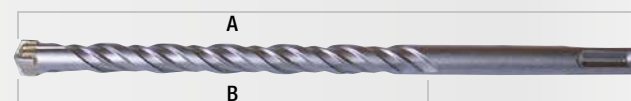

cztery wiertła z przyrębem wyczynów i żywotności



N.p.	specyfikacja	A mm	B mm	
20748	Ø 6 mm	110	40	50
20749	Ø 6 mm	160	90	50
20750	Ø 6 mm	210	140	50
20751	Ø 6 mm	260	190	50
20861	Ø 6,5 mm	230	160	50
20862	Ø 6,5 mm	300	230	50
20752	Ø 8 mm	110	40	50
20753	Ø 8 mm	160	90	50
20754	Ø 8 mm	210	140	50
20755	Ø 8 mm	260	190	50
20825	Ø 8 mm	350	280	50
20756	Ø 10 mm	160	90	50
20757	Ø 10 mm	210	140	50
20758	Ø 10 mm	260	190	50
20759	Ø 10 mm	350	280	50
20760	Ø 10 mm	450	380	50
20761	Ø 10 mm	600	530	50
20762	Ø 10 mm	1000	930	50
20764	Ø 12 mm	160	80	50
20765	Ø 12 mm	210	130	50
20766	Ø 12 mm	260	180	50
20767	Ø 12 mm	350	270	50

N.p.	specyfikacja	A mm	B mm	
20768	Ø 12 mm	460	380	50
20769	Ø 12 mm	600	520	25
20770	Ø 12 mm	1000	920	25
20771	Ø 14 mm	160	80	25
20772	Ø 14 mm	260	180	25
20773	Ø 14 mm	350	270	25
20774	Ø 14 mm	460	380	25
20775	Ø 14 mm	600	520	25
20776	Ø 14 mm	1000	920	30
20777	Ø 16 mm	160	80	25
20778	Ø 16 mm	210	130	25
20779	Ø 16 mm	260	180	25
20780	Ø 16 mm	350	270	25
20781	Ø 16 mm	460	380	25
20782	Ø 16 mm	600	520	30
20783	Ø 16 mm	1000	920	25
20784	Ø 18 mm	260	180	25
20785	Ø 18 mm	450	370	25
20786	Ø 18 mm	600	520	32
20787	Ø 18 mm	1000	920	20
20788	Ø 20 mm	450	370	20
20789	Ø 20 mm	600	520	20

N.p.	specyfikacja	A mm	B mm	
20790	Ø 20 mm	800	720	25
20791	Ø 20 mm	1000	920	10
20792	Ø 22 mm	450	365	20
20793	Ø 22 mm	600	520	20
20794	Ø 22 mm	800	715	20
20795	Ø 22 mm	1000	920	10
20796	Ø 24 mm	450	365	10
20797	Ø 24 mm	600	520	20
20798	Ø 24 mm	800	715	10
20799	Ø 24 mm	1000	920	10
20870	Ø 26 mm	450	370	10
20871	Ø 26 mm	650	570	20
20872	Ø 26 mm	800	720	10
20873	Ø 26 mm	1000	920	10
20874	Ø 28 mm	450	365	10
20875	Ø 28 mm	600	565	20
20876	Ø 28 mm	800	715	10
20877	Ø 28 mm	1000	915	10
20878	Ø 30 mm	450	365	10
20879	Ø 30 mm	600	565	20
20880	Ø 30 mm	800	715	10
20881	Ø 30 mm	1000	915	10

FESTA

WIERTŁA WIDIOWE UDAROWE SDS MAX

SDS MAX

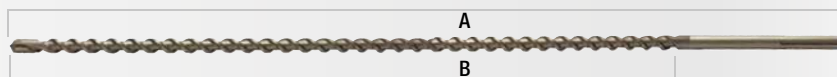

cztery wiertła z przyrębem wyczynów i żywotności



N.p.	specyfikacja	A mm	B mm	
20508	Ø 16 mm	550	395	5
20510	Ø 18 mm	550	395	5
20520	Ø 18 mm	800	650	5
20511	Ø 20 mm	550	395	5
20521	Ø 20 mm	800	650	5

N.p.	specyfikacja	A mm	B mm	
20512	Ø 22 mm	550	395	5
20522	Ø 22 mm	800	650	5
20513	Ø 24 mm	550	395	5
20523	Ø 24 mm	800	650	5
20514	Ø 28 mm	550	395	5

N.p.	specyfikacja	A mm	B mm	
20524	Ø 28 mm	800	650	5
20515	Ø 30 mm	550	395	5
20525	Ø 30 mm	800	650	5
20516	Ø 40 mm	550	395	2
20526	Ø 40 mm	800	650	1

ZESTAW WIERTEŁ SDS+

5x SDS+



N.p.	specyfikacja		
20890	Ø 5, 6, 8, 10, 12 mm	160 mm	25



ZESTAW WIERTEŁ SDS+

6x SDS+



N.p.	specyfikacja		
20891	Ø 5, 6, 8 mm Ø 8, 10, 12 mm	110 mm 160 mm	25



ZESTAW WIERTEŁ

6x DIN 8039



N.p.	specyfikacja		
20895	Ø 5, 6, 8, 10, 12 mm		25



ZESTAW WIERTEŁ



N.p.	specyfikacja		
20805	5 szt. Ø 4 - 10 mm		10
20820	8 szt. Ø 3 - 10 mm		10



FESTA

DŁUTA W ZESTAWIE

SDS+

4x



N.p.	specyfikacja		
20954	250 mm		1

STOISKO PROMOCYJNE

N.p.	specyfikacja		
20999			1

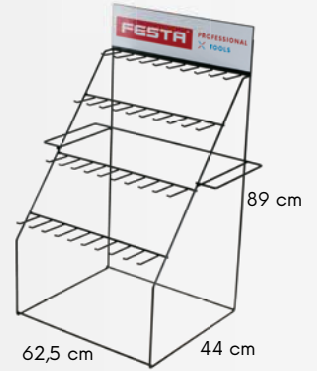

FESTA

ZESTAW SDS+

- 2 x przebijak
- 3 x dłuto
- 12 x wiertło Ø 5-12 mm

17x SDS+



N.p.	specyfikacja		
20952			1



FESTA

ZESTAW SDS+

- 1 x przebijak 250 mm
- 1 x bruzdownica 22 x 250 mm
- 1 x dłuto 20 x 250 mm

- Ø 5 x 110 mm
- Ø 6 x 110 mm
- Ø 8 x 160 mm
- Ø 10 x 160 mm
- Ø 12 x 160 mm
- Ø 14 x 210 mm
- Ø 16 x 210 mm
- Ø 18 x 310 mm
- Ø 20 x 450 mm

12x SDS+



N.p.	specyfikacja		
20950			5



FESTA

DŁUTO

SDS+



N.p.	specyfikacja		
20996	250 x 100 mm		1



NEW



FESTA

DŁUTO

SDS+

N.p.	specyfikacja	
20997	445 x 130 mm	1

NEW



FESTA

DŁUTO

SDS MAX

N.p.	specyfikacja	
20932	450 x 100 mm	1

FESTA

DŁUTO, 15°

SDS+

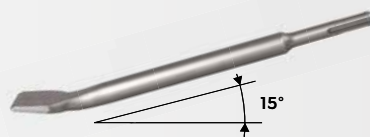

N.p.	specyfikacja	
20936	40 x 250 mm	5

FESTA

DŁUTO

SDS+



N.p.	specyfikacja	
20948	20 x 250 mm	25
20990	20 x 400 mm	25
20949	40 x 250 mm	25
20991	40 x 400 mm	25

FESTA

DŁUTO

SDS MAX



N.p.	specyfikacja	
20940	25 x 280 mm	5
20941	40 x 280 mm	5
20942	75 x 280 mm	5
20943	25 x 400 mm	5
20944	40 x 400 mm	5
20945	25 x 600 mm	5
20946	50 x 600 mm	5

FESTA

PRZEBIJAK

SDS+



N.p.	specyfikacja	
20947	250 mm	25
20992	400 mm	25

FESTA

PRZEBIJAK

SDS MAX



N.p.	specyfikacja	
20937	∅ 18 x 280 mm	5
20938	∅ 18 x 400 mm	5
20939	∅ 18 x 600 mm	2

FESTA

BRUZDOWNICA

SDS+



N.p.	specyfikacja	
20956	22 x 250 mm	25

FESTA

KORONKA Z WIERTŁEM
SDS+

uchwyt mocujący do koronek wiertniczych 24730, 24731 a 24732

SDS+



N.p.	specyfikacja	
24719	∅ 67 mm	1
24717	∅ 73 mm	1
24723	∅ 80 mm	1
24718	∅ 100 mm	1
24757	∅ 115 mm	1
24758	∅ 125 mm	1
24759	∅ 150 mm	1

FESTA

UCHWYT MOCUJĄCY DO
KORONEK WIERTNICZYCH

SDS MAX



N.p.	specyfikacja	
24730	180 mm	1

FESTA

UCHWYT MOCUJĄCY DO
KORONEK WIERTNICZYCH

SDS+



N.p.	specyfikacja	
24731	300 mm	1
24732		1



FESTA

ZESTAW KORONEK



6x



N.p.	specyfikacja	
24745	Ø 33, 53, 67, 73 mm + kołek, wiertło	1



FESTA

ZESTAW KORONEK + PILNIK



8x

N.p.	specyfikacja	
24747	Ø 33, 53, 67, 73, 83 mm kołek, wiertło, pilnik	1

FESTA

KORONKA WOLFRAMOWA

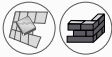

N.p.	specyfikacja	
24735	Ø 33 mm	1
24736	Ø 43 mm	1
24737	Ø 53 mm	1
24738	Ø 67 mm	1
24739	Ø 73 mm	1
24740	Ø 83 mm	1
24741	Ø 103 mm	1



FESTA

ZESTAW KORONEK

3x



N.p.	specyfikacja	
24746	Ø 103 mm + kołek, wiertło	1



FESTA

WIERTŁO CENTRUJĄCE DO OTWORNIC WOLFRAMOWYCH

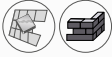

N.p.	specyfikacja	
24749		50



FESTA

TALERZ DO OTWORNIC WOLFRAMOWYCH



N.p.	specyfikacja	
24748	Ø 33 - 83 mm	10
24743	Ø 33 - 103 mm	10



FESTA

KORONKA - WĘGLIK

· do wiercenia szkła i ceramiki



N.p.	specyfikacja	
24770	Ø 4 mm	1
24771	Ø 6 mm	1
24772	Ø 8 mm	1
24773	Ø 10 mm	1
24774	Ø 12 mm	1



WYCINAK DO GLAZURY

N.p.	specyfikacja	
24726	Ø 20-95mm	1



WYCINAK DO GLAZURY

N.p.	specyfikacja	
24725	Ø 20-95mm	10



FESTA

PILNIK WOLFRAMOWY DO PŁYTEK



N.p.	specyfikacja	
22200	160 mm	20



FESTA

PILNIK WOLFRAMOWY DO PŁYTEK

· do szlifowania cegieł przed wstawieniem kotwy ściennej



N.p.	specyfikacja	
22201	200 mm dwojń chropowatość	20





KORONKA DIAMENTOWA SET

- Ø 6 mm
- Ø 8 mm
- Ø 10 mm
- Ø 12 mm
- Ø 20 mm
- Ø 28 mm
- Ø 35 mm
- Ø 45 mm
- Ø 55 mm
- Ø 68 mm



tarcze tnące / szlifierskie Ø 125 mm x 2,0 mm Ø 22,2 mm
tarcze tnące Ø 125 mm x 1,2 mm Ø 22,2 mm

koronka szlifierska diamentowa Ø 0 - 50 mm
diamentowa gąbka ścierna 90 x 55 mm P60

13x M14

- do płytek ceramicznych
- do marmuru
- do granitu

- nie wymaga chłodzenia



N.p.	Specyfikacja	
24652		1



KORONKA DIAMENTOWA

M14

- do płytek ceramicznych
- do marmuru
- do granitu

- nie wymaga chłodzenia



N.p.	Specyfikacja	
24620	Ø 6 mm M14	1
24621	Ø 8 mm M14	1
24622	Ø 10 mm M14	1
24623	Ø 12 mm M14	1
24624	Ø 14 mm M14	1
24627	Ø 20 mm M14	1
24630	Ø 28 mm M14	1
24633	Ø 35 mm M14	1
24636	Ø 45 mm M14	1
24638	Ø 55 mm M14	1
24640	Ø 68 mm M14	1
24642	NEW Ø 72 mm M14	1
24643	Ø 75 mm M14	1



KORONKA DIAMENTOWA SET

- Ø 6 mm
- Ø 8 mm
- Ø 10 mm
- Ø 20 mm
- Ø 35 mm
- Ø 45 mm
- Ø 55 mm
- Ø 68 mm

8x M14

- do płytek ceramicznych
- do marmuru
- do granitu

- nie wymaga chłodzenia



N.p.	Specyfikacja	
24651		1



KORONKA SZLIFIERSKA DIAMENTOWA

M14

- do płytek ceramicznych
- do marmuru
- do granitu

- nie wymaga chłodzenia



N.p.	Specyfikacja	
24795	Ø 20 / 50 mm	1
24797	Ø 6 / 50 mm	1
24799	Ø 10 / 50 mm	1



KORONKA SZLIFIERSKA DIAMENTOWA

M14

- do płytek ceramicznych
- do marmuru
- do granitu

- nie wymaga chłodzenia



N.p.	Specyfikacja	
24775	NEW Ø 2 - 35 mm	1
24777	Ø 2 - 75 mm	1
24778	Ø 2 - 50 mm	1



· Ø 2 mm - Ø 75 mm



KORONKA SZLIFIERSKA DIAMENTOWA

M14

- do płytek ceramicznych
- do marmuru
- do granitu

nie wymaga chłodzenia



N.p.	Specyfikacja	1
24779	Ø 20 - 48 mm	1



DIAMENTOWA KORONKA SZLIFIERSKA

M14

- do płytek ceramicznych
- do marmuru
- do granitu

nie wymaga chłodzenia



N.p.	Specyfikacja	1
24663	Ø 50 mm	1



KORONKA DIAMENTOWA

M14

- do płytek ceramicznych
- do marmuru
- do granitu

nie wymaga chłodzenia



N.p.	specyfikacja	uchyt	1	N.p.	specyfikacja	uchyt	1
24760	Ø 6 mm	M14	1	24766	Ø 35 mm	M14	1
24761	Ø 8 mm	M14	1	24776	Ø 40 mm	M14	1
24762	Ø 10 mm	M14	1	24767	Ø 45 mm	M14	1
24763	Ø 12 mm	M14	1	24791	Ø 50 mm	M14	1
24764	Ø 14 mm	M14	1	24768	Ø 53 mm	M14	1
24670	Ø 16 mm	M14	1	24792	Ø 60 mm	M14	1
24671	Ø 18 mm	M14	1	24793	Ø 65 mm	M14	1
24790	Ø 20 mm	M14	1	24769	Ø 68 mm	M14	1
24672	Ø 22 mm	M14	1	24794	Ø 75 mm	M14	1
24673	Ø 25 mm	M14	1	24796	Ø 83 mm	M14	1
24765	Ø 28 mm	M14	1	24677	Ø102 mm	M14	1
24674	Ø 30 mm	M14	1	24676	Ø 110 mm	M14	1
24675	Ø 32 mm	M14	1	24678	Ø125 mm	M14	1



DIAMENTOWA KORONKA SZLIFIERSKA

M14

- do płytek ceramicznych
- do marmuru
- do granitu

nie wymaga chłodzenia



N.p.	Specyfikacja	1
24661	Ø 50 mm	1



KORONKA DIAMENTOWA

7x M14

- do płytek ceramicznych
- do marmuru
- do granitu

nie wymaga chłodzenia



N.p.	Specyfikacja	1
24650		1



KORONKA DIAMENTOWA

- do płytek ceramicznych
- do marmuru
- do granitu

N.p.	specyfikacja	1
24700	Ø 6 mm	1
24701	Ø 8 mm	1
24702	Ø 10 mm	1
24703	Ø 12 mm	1
24704	Ø 14 mm	1
24705	Ø 20 mm	1



FESTA

WOSK CHŁODZĄCY
DO OTWORNICY
DIAMENTOWEJ



N.p.	Specyfikacja	
24710	30 ml	1

FESTA

KORONKA
DIAMENTOWA



6x

- do płytek ceramicznych
- do marmuru
- do granitu

N.p.	specyfikacja	
24798	Ø 6, 8, 10, 12, 14, 20 mm	1



FESTA

TARCZA TNĄCA,
SZLIFIERSKA -
DIAMENTOWA

M14

- do płytek ceramicznych
- do marmuru
- do granitu

- nie wymaga chłodzenia

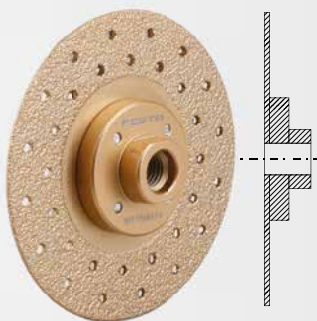

N.p.	Specyfikacja	
24655	Ø 115 mm M14	1

FESTA

TARCZA SZLIFIERSKA -
DIAMENTOWA

- do płytek ceramicznych
- do marmuru
- do granitu

- nie wymaga chłodzenia

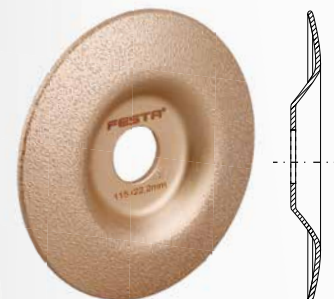

N.p.	Specyfikacja	
24658	Ø 115 mm Ø 22,2 mm	1

FESTA

WIERTŁO DO SZKŁA
I CERAMIKI

TiN 1/4"

-
-
-

N.p.	specyfikacja	
24780	Ø 4 mm	40
24781	Ø 5 mm	40
24782	Ø 6 mm	40
24783	Ø 8 mm	40
24784	Ø 10 mm	40
24785	Ø 12 mm	40
24786	Ø 14 mm	1
24787	Ø 16 mm	1
24788	Ø 18 mm	1
24789	Ø 20 mm	1



FESTA

WIERTŁO DO SZKŁA I
CERAMIKI - ZESTAW

- Ø 4 mm
- Ø 5 mm
- Ø 6 mm
- Ø 8 mm
- Ø 10 mm

5x

- do płytek ceramicznych
- do marmuru
- do granitu

- nie wymaga chłodzenia



N.p.	specyfikacja	
24734		1



TARCZE DIAMENTOWE
TNĄCE / SZLIFIERSKIE

- do płytek ceramicznych
- do marmuru
- do granitu

nie wymaga chłodzenia



N.p.	specyfikacja		
21230	Ø 115 mm x 1,8 mm	Ø 22,2 mm	1
21231	Ø 125 mm x 2,0 mm	Ø 22,2 mm	1



TARCZE DIAMENTOWE TNĄCE
TURBO EXTREME

- do płytek ceramicznych
- do marmuru
- do granitu

nie wymaga chłodzenia

N.p.	specyfikacja		
21205	Ø 125 mm x 2,0 mm	Ø 22,2 mm	1
21209	Ø 230 mm x 2,6 mm	Ø 22,2 mm	1



TARCZE DIAMENTOWE TNĄCE

- do płytek ceramicznych
- do marmuru
- do granitu

nie wymaga chłodzenia

N.p.	specyfikacja		
21234 NEW	Ø 115 mm x 1,2 x 8 mm	Ø 22,2 mm	1
21235	Ø 125 mm x 1,2 x 8 mm	Ø 22,2 mm	1
21238 NEW	Ø 200 mm x 1,6 x 11 mm	Ø 25,4 mm	1



TARCZE DIAMENTOWE

- do płytek ceramicznych
- do marmuru
- do granitu

nie wymaga chłodzenia

N.p.	specyfikacja		
21200	Ø 115 mm 1,4 mm	Ø 22,2 mm	1
21201	Ø 125 mm 1,4 mm	Ø 22,2 mm	1
21204	Ø 200 mm 1,8 mm	Ø 25,4 mm	1
21203	Ø 230 mm 1,8 mm	Ø 22,2 mm	1



FESTA

TARCZE DIAMENTOWE SEGMENTOWE

N.p.	specyfikacja		
21311	Ø 115 mm	Ø 22,2 mm	1
21312	Ø 125 mm	Ø 22,2 mm	1
21315	Ø 150 mm	Ø 22,2 mm	1
21318	Ø 180 mm	Ø 22,2 mm	1
21323	Ø 230 mm	Ø 22,2 mm	1
21324	Ø 300 mm	Ø 25,4 mm	1
21327	Ø 350 mm	Ø 25,4 mm	1
21326	Ø 400 mm	Ø 25,4 mm	1



FESTA

TARCZE DIAMENTOWE TURBO

N.p.	specyfikacja		
21411	Ø 115 mm	Ø 22,2 mm	1
21412	Ø 125 mm	Ø 22,2 mm	1
21415	Ø 150 mm	Ø 22,2 mm	1
21418	Ø 180 mm	Ø 22,2 mm	1
21423	Ø 230 mm	Ø 22,2 mm	1
21424	Ø 300 mm	Ø 25,4 mm	1



FESTA

TARCZE DIAMENTOWE PEŁNE

N.p.	specyfikacja		
21210	Ø 110 mm	Ø 22,2 mm	1
21211	Ø 115 mm	Ø 22,2 mm	1
21212	Ø 125 mm	Ø 22,2 mm	1
21215	Ø 150 mm	Ø 22,2 mm	1
21218	Ø 180 mm	Ø 22,2 mm	1
21219	Ø 180 mm	Ø 25,4 mm	1
21220	Ø 200 mm	Ø 25,4 mm	1
21223	Ø 230 mm	Ø 22,2 mm	1
21224	Ø 300 mm	Ø 25,4 mm	1



FESTA
INDUSTRY

**UNIWERSALNA TARCZA
TNĄCA - DIAMENT**



N.p.	specyfikacja		
21301	Ø 125 mm	Ø 22,2 mm	1,5 mm
21303	Ø 230 mm	Ø 22,2 mm	1,8 mm



FESTA

**TARCZE DIAMENTOWE
SEGMENTOWANE, PODWÓJNE**



N.p.	specyfikacja		
21195	Ø 125 x	Ø 22,2 mm	1



6 mm

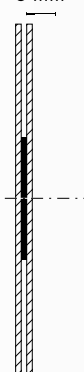

TARCZE DIAMENTOWE PEŁNE

N.p.	specyfikacja		
21010	Ø 110 mm	Ø 22,2 mm	1
21011	Ø 115 mm	Ø 22,2 mm	1
21012	Ø 125 mm	Ø 22,2 mm	1
21015	Ø 150 mm	Ø 22,2 mm	1
21018	Ø 180 mm	Ø 22,2 mm	1
21023	Ø 230 mm	Ø 22,2 mm	1



TARCZE DIAMENTOWE SEGMENTOWE

N.p.	specyfikacja		
21110	Ø 110 mm	Ø 22,2 mm	1
21111	Ø 115 mm	Ø 22,2 mm	1
21112	Ø 125 mm	Ø 22,2 mm	1
21115	Ø 150 mm	Ø 22,2 mm	1
21118	Ø 180 mm	Ø 22,2 mm	1
21123	Ø 230 mm	Ø 22,2 mm	1



TARCZE DIAMENTOWE TURBO

N.p.	specyfikacja		
21130	Ø 110 mm	Ø 22,2 mm	1
21135	Ø 115 mm	Ø 22,2 mm	1
21140	Ø 125 mm	Ø 22,2 mm	1
21150	Ø 150 mm	Ø 22,2 mm	1
21180	Ø 180 mm	Ø 22,2 mm	1
21190	Ø 230 mm	Ø 22,2 mm	1





FESTA

TARCZE DIAMENTOWE



N.p.	specyfikacja		
21435	Ø 115 mm	Ø 22,2 mm	1
21436	Ø 125 mm	Ø 22,2 mm	1
21437	Ø 150 mm	Ø 22,2 mm	1



FESTA

TARCZE DIAMENTOWE



N.p.	specyfikacja		
21430	Ø 115 mm	Ø 22,2 mm	1
21431	Ø 125 mm	Ø 22,2 mm	1
21432	Ø 150 mm	Ø 22,2 mm	1



FESTA

TARCZA SZLIFIERSKA TURBO



N.p.	specyfikacja		
21425	Ø 100 mm	Ø 22,2 mm	1
21426	Ø 115 mm	Ø 22,2 mm	1
21427	Ø 125 mm	Ø 22,2 mm	1
21428	Ø 150 mm	Ø 22,2 mm	1



FESTA
INDUSTRY

TARCZE TNĄCE DO METALU



N.p.	specyfikacja		
22258	Ø 115 mm	Ø 22,2 mm x 0,8 mm	25
22260	Ø 115 mm	Ø 22,2 mm x 1 mm	25
22263	Ø 115 mm	Ø 22,2 mm x 1,6 mm	25
22264	Ø 115 mm	Ø 22,2 mm x 2 mm	25
22259	Ø 125 mm	Ø 22,2 mm x 0,8 mm	25
22266	Ø 125 mm	Ø 22,2 mm x 1 mm	25
22269	Ø 125 mm	Ø 22,2 mm x 1,6 mm	25
22270	Ø 125 mm	Ø 22,2 mm x 2 mm	25
22273	Ø 150 mm	Ø 22,2 mm x 1,6 mm	25
22274	Ø 150 mm	Ø 22,2 mm x 2 mm	25
22275	Ø 150 mm	Ø 22,2 mm x 2,5 mm	25
22277	Ø 180 mm	Ø 22,2 mm x 2 mm	25
22280	Ø 230 mm	Ø 22,2 mm x 2 mm	25
22281	Ø 230 mm	Ø 22,2 mm x 2,5 mm	25



FESTA
INDUSTRY

TARCZE TNĄCE DO ALUMINIUM



N.p.	specyfikacja		
22285	Ø 115 mm	Ø 22,2 mm x 1 mm	1
22286	Ø 125 mm	Ø 22,2 mm x 1 mm	1



FESTA
INDUSTRY

TARCZE TNĄCE DO KAMIENIA



N.p.	specyfikacja		
22294	Ø 230 mm	Ø 22,2 mm x 3 mm	1



FESTA

TARCZE TNĄCE DO METALU



N.p.	specyfikacja			
22211	Ø 115 mm	Ø 22,2 mm x 1 mm	INOX	50
22212	Ø 115 mm	Ø 22,2 mm x 1,2 mm	INOX	50
22225	Ø 125 mm	Ø 22,2 mm x 1 mm	INOX	50
22217	Ø 125 mm	Ø 22,2 mm x 1,2 mm	INOX	50

FESTA

TARCZE TNĄCE DO METALU

10x



N.p.	specyfikacja			
22228	Ø 115 mm	Ø 22,2 mm x 1 mm	INOX	1
22229	Ø 125 mm	Ø 22,2 mm x 1,2 mm	INOX	1

FESTA

TARCZE TNĄCE DO METALU



N.p.	specyfikacja			
22251	Ø 115 mm	Ø 22,2 mm x 1,6 mm		50
22215	Ø 115 mm	Ø 22,2 mm x 2 mm		50
22216	Ø 115 mm	Ø 22,2 mm x 2,5 mm		50
22252	Ø 125 mm	Ø 22,2 mm x 1,6 mm		25
22218	Ø 125 mm	Ø 22,2 mm x 2,5 mm		25
22219	Ø 150 mm	Ø 22,2 mm x 1,2 mm		25
22253	Ø 150 mm	Ø 22,2 mm x 1,6 mm		50
22220	Ø 150 mm	Ø 22,2 mm x 2,5 mm		50
22254	Ø 180 mm	Ø 22,2 mm x 1,6 mm		50
22222	Ø 180 mm	Ø 22,2 mm x 2,5 mm		25
22255	Ø 230 mm	Ø 22,2 mm x 1,6 mm		25
22224	Ø 230 mm	Ø 22,2 mm x 2,5 mm		25

FESTA

TARCZE SZLIFIERSKIE DO METALU



N.p.	specyfikacja			
22240	Ø 115 mm	Ø 22,2 mm x 6,4 mm		25
22242	Ø 125 mm	Ø 22,2 mm x 6,4 mm		25
22244	Ø 150 mm	Ø 22,2 mm x 6,4 mm		25
22246	Ø 180 mm	Ø 22,2 mm x 6,4 mm		25
22248	Ø 230 mm	Ø 22,2 mm x 6,4 mm		25

FESTA

TARCZE TNĄCE DO METALU DIAMENT



N.p.	specyfikacja			
21306	Ø 125 mm	Ø 22,2 mm	1,3 mm	1
21308	Ø 230 mm	Ø 22,2 mm	1,8 mm	1

FESTA

TARCZE TNĄCE DO KAMIENIA



N.p.	specyfikacja			
22230	Ø 115 mm	Ø 22,2 mm x 2,5 mm		50
22232	Ø 125 mm	Ø 22,2 mm x 2,5 mm		50
22234	Ø 150 mm	Ø 22,2 mm x 2,5 mm		25
22236	Ø 180 mm	Ø 22,2 mm x 2,5 mm		25
22238	Ø 230 mm	Ø 22,2 mm x 2,5 mm		25

FESTA

UNIWERSALNA TARCZA TNĄCA CARBID



N.p.	specyfikacja			
21192	Ø 125 mm	Ø 22,2 mm		1
21194	Ø 230 mm	Ø 22,2 mm		1

FESTA

TARCZA
TARNIKOWA



N.p.	specyfikacja			
21806	Ø 125 mm	Ø 22,2 mm		1

20 mm



FESTA

TARCZA
TARNIKOWA
ŚREDNIO GRUBA



N.p.	specyfikacja				
21802	Ø 125 mm	Ø 22,2 mm	3 mm		10



FESTA

TARCZA
TARNIKOWA
GRUBA



N.p.	specyfikacja			
21801	Ø 125 mm	Ø 22,2 mm	3 mm	10

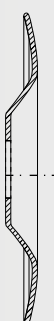

FESTA

PILA / DYSK
TARCZOWY



N.p.	Specyfikacja			
21803	Ø 125 mm	Ø 22,2 mm		1

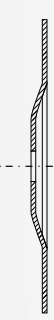

NEW

FESTA

TARCZA
TARNIKOWA



N.p.	Specyfikacja		
21805	Ø 125 mm	Ø 22,2 mm	1

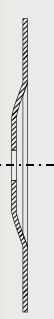

FESTA

TARCZA
DO DREWNA
Z OTWORAMI

Tarcza szlifierska nadaje się do szlifowania drewna



N.p.	specyfikacja		
21800	Ø 125 mm	Ø 22,2 mm	1

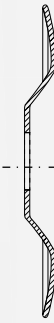

FESTA

TARNIK CYLINDRYCZNY

M14



N.p.	specyfikacja		
21807	Ø 30 mm / 60 mm		1

40 mm



FESTA

TARNIK KULKOWY

M14



N.p.	specyfikacja		
21808	Ø 30 mm / 105 mm		10

65 mm



TARCZE TNĄCE



N.p.	Specyfikacja			
21804	Ø 125 mm	Ø 22,2 mm	14T	1

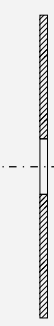

NEW



TARCZE
TNĄCE



N.p.	Specyfikacja		
21809	Ø 125 mm x 4T	Ø 22,2 mm	1

NEW

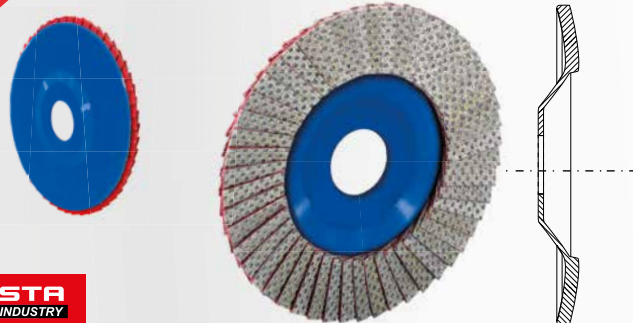

FESTA
INDUSTRY

TARCZA LAMELOWA
DIAMENTOWA



- do płytek ceramicznych
- do marmuru
- do granitu



- nie wymaga chłodzenia

N.p.	specyfikacja			
24647	Ø 115 mm	Ø 22,2 mm	● P60	1
24648	Ø 115 mm	Ø 22,2 mm	● P120	1
24649	Ø 115 mm	Ø 22,2 mm	● P200	1

NEW



FESTA

TARCZA
LAMELOWA



N.p.	specyfikacja	chropowatość	
21760	Ø 125 mm Ø 22,2 mm	P40	10
21761	Ø 125 mm Ø 22,2 mm	P60	10
21762	Ø 125 mm Ø 22,2 mm	P80	10
21763	Ø 125 mm Ø 22,2 mm	P100	10
21764	Ø 125 mm Ø 22,2 mm	P120	10

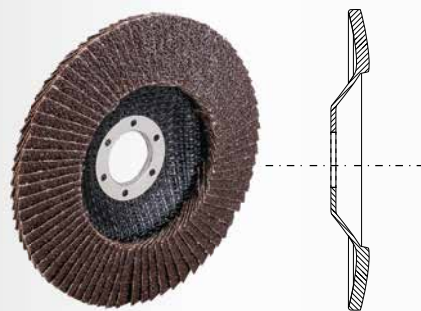

TARCZA LAMELOWA



N.p.	specyfikacja		chropowatość	
21780	Ø 115 mm	Ø 22,2 mm	P40	10
21781	Ø 115 mm	Ø 22,2 mm	P60	10
21782	Ø 115 mm	Ø 22,2 mm	P80	10
21783	Ø 115 mm	Ø 22,2 mm	P100	10
21784	Ø 115 mm	Ø 22,2 mm	P120	10
21786	Ø 125 mm	Ø 22,2 mm	P40	10
21787	Ø 125 mm	Ø 22,2 mm	P60	10
21788	Ø 125 mm	Ø 22,2 mm	P80	10
21789	Ø 125 mm	Ø 22,2 mm	P100	10
21790	Ø 125 mm	Ø 22,2 mm	P120	10
21792	Ø 150 mm	Ø 22,2 mm	P40	10
21793	Ø 150 mm	Ø 22,2 mm	P60	10
21794	Ø 150 mm	Ø 22,2 mm	P80	10
21795	Ø 150 mm	Ø 22,2 mm	P100	10
21796	Ø 150 mm	Ø 22,2 mm	P120	10

FESTA

TARCZA LAMELOWA

grinding disc suitable for gringing stainless steel



N.p.	specyfikacja	chropowatość	
22140	Ø 115 mm Ø 22,2 mm	P40	5
22141	Ø 115 mm Ø 22,2 mm	P60	5
22142	Ø 115 mm Ø 22,2 mm	P80	5
22143	Ø 115 mm Ø 22,2 mm	P100	5
22145	Ø 125 mm Ø 22,2 mm	P40	5
22146	Ø 125 mm Ø 22,2 mm	P60	5
22147	Ø 125 mm Ø 22,2 mm	P80	5
22148	Ø 125 mm Ø 22,2 mm	P100	5
22150	Ø 150 mm Ø 22,2 mm	P40	5
22151	Ø 150 mm Ø 22,2 mm	P60	5
22155	Ø 150 mm Ø 22,2 mm	P80	5
22156	Ø 150 mm Ø 22,2 mm	P100	5

SZCZOTKA NYLON
Z PODSTAWKĄ



N.p.	specyfikacja	
21798	Ø 125 mm Ø 22,2 mm	1



FESTA



20mm

FESTA

SZCZOTKA DRUCIANA, TARCZOWA

· pokryta mosiądzem

M14



N.p.	specyfikacja	drut	
21900	Ø 100 mm M14	s 0,3	60
21902	Ø 125 mm M14	s 0,3	42



10mm

FESTA

SZCZOTKA DRUCIANA, TARCZOWA

· pokryta mosiądzem

M14



N.p.	specyfikacja	drut	
22001	Ø 100 mm M14	s 0,3	60
21901	Ø 125 mm M14	s 0,3	42



FESTA

SZCZOTKA DRUCIANA, TARCZOWA

· mosiężna,

M14



N.p.	specyfikacja	drut	
21920	Ø 100 mm M14	s 0,3	60



FESTA

SZCZOTKA DRUCIANA

· pokryta mosiądzem

M14



N.p.	specyfikacja	drut	
21903	Ø 65 mm M14	s 0,3	60
22002	Ø 75 mm M14	s 0,3	80
21904	Ø 85 mm M14	s 0,3	60
22003	Ø 100 mm M14	s 0,3	36
21905	Ø 125 mm M14	s 0,3	24
21906	Ø 150 mm M14	s 0,3	12



FESTA

SZCZOTKA DRUCIANA

· mosiężna,

M14



N.p.	specyfikacja	drut	
21925	Ø 75 mm M14	0,3 mm	80
21926	Ø 100 mm M14	0,3 mm	36



FESTA

SZCZOTKA OKRĄGLA, POFALOWANA

· pokryta mosiądzem

· krążki redukcyjne

M14



N.p.	specyfikacja	drut	
22007	Ø 100 mm Ø 20 mm	s 0,3	60
22008	Ø 125 mm Ø 20 mm	s 0,3	42
22009	Ø 150 mm Ø 32,2 mm	s 0,3	32
22010	Ø 175 mm Ø 32,2 mm	s 0,3	20
22011	Ø 200 mm Ø 32,2 mm	s 0,3	20



FESTA

SZCZOTKA DRUCIANA

· utwardzona

INOX M14



N.p.	specyfikacja	drut	
22037	Ø 65 mm M14	s 0,5	60
22038	Ø 80 mm M14	s 0,5	24



FESTA

SZCZOTKA DRUCIANA

· utwardzona

M14



N.p.	specyfikacja	drut	
22004	Ø 65 mm M14	s 0,3	60
22005	Ø 75 mm M14	s 0,3	24
22006	Ø 100 mm M14	s 0,3	24
21907	Ø 125 mm M14	s 0,3	24
21908	Ø 150 mm M14	s 0,3	12



FESTA

SZCZOTKA RADIALNA

· utwardzona

M14



N.p.	specyfikacja	drut	počet copů	
21911	Ø 100 mm M14	s 0,5	30	60
21912	Ø 115 mm M14	s 0,5	32	42
21913	Ø 125 mm M14	s 0,5	36	42
21914	Ø 150 mm M14	s 0,5	40	32



FESTA

SZCZOTKA RADIALNA

· utwardzona

M14

N.p.	specyfikacja	dрут	
22012	Ø 100 mm M14	s 0,5	60
22013	Ø 115 mm M14	s 0,5	42
22014	Ø 125 mm M14	s 0,5	42
22015	Ø 150 mm M14	s 0,5	32
22016	Ø 178 mm M14	s 0,5	20



FESTA

SZCZOTKA RADIALNA

· utwardzona

INOX M14

N.p.	specyfikacja	dрут	
22039	Ø 100 mm M14	s 0,5	60
22040	Ø 125 mm M14	s 0,5	42



FESTA

SZCZOTKA DRUCIANA

· utwardzona

M14

N.p.	specyfikacja	dрут	
22017	Ø 100 mm M14	s 0,5	60
21909	Ø 115 mm M14	s 0,5	42
21910	Ø 125 mm M14	s 0,5	42



FESTA

SZCZOTKA DRUCIANA – SKRĘTNA, TARCZOWA

· utwardzona

N.p.	specyfikacja	dрут	
22023	Ø 75 mm	s 0,5	10



FESTA

SZCZOTKA DRUCIANA – SKRĘTNA, DOCZOŁOWA

· utwardzona

N.p.	specyfikacja	dрут	
22024	Ø 75 mm	s 0,5	12



FESTA

SZCZOTKA DRUCIANA DOCZOŁOWA

· utwardzona

N.p.	specyfikacja	dрут	
22025	Ø 75 mm	s 0,5	12

NEW



FESTA

SZCZOTKA DRUCIANA SKRĘTNA, TARCZOWA

N.p.	specyfikacja	dрут	
21950	Ø 200 mm 25,4 mm		1



FESTA

SZCZOTKA DRUCIANA – DOCZOŁOWA

· pokryta mosiądzem

N.p.	specyfikacja	dрут	
22030	Ø 65 mm	s 0,3	12
22031	Ø 75 mm	s 0,3	12



FESTA

SZCZOTKA DRUCIANA – TARCZOWA

· pokryta mosiądzem

N.p.	specyfikacja	dрут	
22026	Ø 50 mm	s 0,3	15
22027	Ø 63 mm	s 0,3	15
22028	Ø 75 mm	s 0,3	10
22029	Ø 100 mm	s 0,3	15



FESTA

SZCZOTKA PĘDZELKOWA

N.p.	specyfikacja	dрут	
22058	Ø 12 mm	s 0,3	25
22059	Ø 25 mm	s 0,3	25



FESTA

SZCZOTKA PĘDZELKOWA

· pokryta mosiądzem

N.p.	specyfikacja	dрут	
22018	Ø 12 mm	s 0,3	15
22019	Ø 17 mm	s 0,3	15
22020	Ø 25 mm	s 0,3	25



FESTA

SZCZOTKA PĘDZELKOWA

· utwardzona

N.p.	specyfikacja	dрут	
22021	Ø 19 mm	s 0,5	30
22022	Ø 22 mm	s 0,5	25



FESTA

SZCZOTKA DOCZOŁOWA

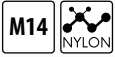

N.p.	specyfikacja	długość	drut	ilość
21940	Ø 75 mm M14	1,2 mm	1	1
21941	Ø 100 mm M14	1,2 mm	1	1



FESTA

SZCZOTKA TARCZOWA



N.p.	specyfikacja	długość	drut	ilość
21930	Ø 125 mm M14	1,2 mm	10	10
21931	Ø 150 mm M14	1,2 mm	15	15

Ø 6 mm



FESTA

SZCZOTKA



N.p.	specyfikacja	długość	drut	ilość
22032	Ø 100 mm	1,2 mm	12	12

Ø 6 mm



FESTA

SZCZOTKA TARCZOWA



N.p.	specyfikacja	długość	drut	ilość
21935	Ø 50 mm	1,2 mm	1	1
21936	Ø 75 mm	1,2 mm	1	1
21937	Ø 100 mm	1,2 mm	1	1



Ø 6 mm

SZCZOTKA NYLON



N.p.	specyfikacja	ilość
22088	Ø 65 mm	9
22090	Ø 100 mm	5



SZCZOTKA NYLON Z PODSTAWKĄ



N.p.	specyfikacja	ilość
22083	Ø 115 mm Ø 22,2 mm	10
22084	Ø 125 mm Ø 22,2 mm	10
22085	Ø 150 mm Ø 22,2 mm	10



SZCZOTKA NYLON



N.p.	specyfikacja	ilość
22095	Ø 178 mm	1

NEW

FESTA

DIAMENTOWA TARCZA ŚCIERNA Z RZEPEM

- do płytek ceramiczne
- do szkła
- do marmuru
- do granitu



• dysk 22043

N.p.	specyfikacja	chropowatość	ilość
24665	Ø 100 mm	● P60	10
24666	Ø 100 mm	● P120	10
24667	Ø 100 mm	● P200	10

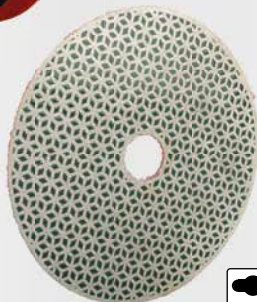

FESTA

DIAMENTOWA TARCZA POLERSKA Ø 100 MM, Z RZEPEM

- do płytek ceramiczne
- do szkła
- do marmuru
- do granitu



• dysk 22043

N.p.	chropowatość	ilość
22701	50	1
22702	100	1
22703	200	1
22704	400	1
22705	800	1
22706	1500	1
22707	3000	1





TARCZA POLERSKA



N.p.	specyfikacja	specyfikacja	
22065	Ø 125 mm	z rzepem	20
22066	Ø 150 mm	z rzepem	20

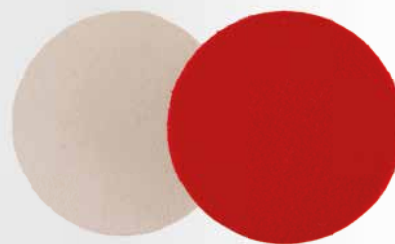

TARCZA POLERSKA



N.p.	specyfikacja	
22070	Ø 115 mm	20
22071	Ø 125 mm z rzepem	20
22072	Ø 150 mm	20

FESTA

DYSK DO KRAŻKÓW ŚCIERNYCH Z RZEPEM

- M14 | Ø 8 mm
- EVA 10 mm

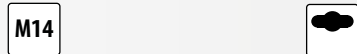

N.p.	specyfikacja	
22062	Ø 115 mm	25
22063	Ø 125 mm	25
22064	Ø 150 mm	10



FESTA

DYSK DO FIBRY

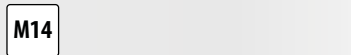

N.p.	specyfikacja	
22073	Ø 125 mm, M14	1
22074	Ø 150 mm, M14	1



FESTA

DYSK DO KRAŻKÓW ŚCIERNYCH

- do szlifierek kątowych
- do 24665-24667, 22701-22707

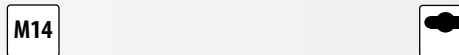

N.p.	specyfikacja	
22043	Ø 100 mm z rzepem	1



DYSK DO KRAŻKÓW ŚCIERNYCH

- do szlifierek kątowych

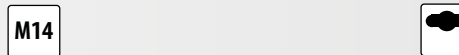

N.p.	specyfikacja	
22044	Ø 125 mm M14 z rzepem	15
22060	Ø 150 mm M14 z rzepem	6



ADAPTER



N.p.	specyfikacja	
22087		1



DYSK DO KRAŻKÓW ŚCIERNYCH

N.p.	specyfikacja	
22061	Ø 125 mm z rzepem	6



DYSK DO KRAŻKÓW ŚCIERNYCH

N.p.	specyfikacja	
22041	Ø 125 mm z rzepem	11
22042	Ø 125 mm z rzepem	11



TARCZA NYLONOWA, ŚCIERNA



N.p.	specyfikacja	
22091	Ø 50 mm P240	1
22092	Ø 75 mm P240	1
22093	Ø 100 mm P240	1

FESTA

KRAŻEK ŚCIERNY FIBROWY - Ø 125 MM



N.p.	chropowość	
22160	P40	1
22161	P60	1
22162	P80	1
22163	P100	1
22164	P120	1



FESTA

KRAŻEK ŚCIERNY FIBROWY - Ø 150 MM



N.p.	chropowość	
22167	P80	1



FESTA

PAPIER ŚCIERNY Ø 125 MM, Z RZEPEM

3x

N.p.	chropowość	
22045	P40	1
22046	P60	1
22047	P80	1
22048	P100	1
22049	P120	1
22050	P150	1
22051	P180	1
22052	P220	1

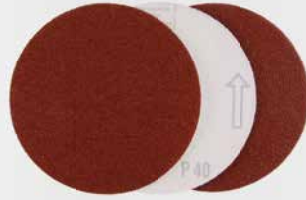

FESTA

PAPIER ŚCIERNY Ø 150 MM, Z RZEPEM

3x

N.p.	chropowość	
22053	P40	1
22054	P60	1
22055	P80	1
22056	P100	1
22057	P120	1

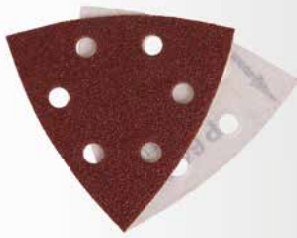
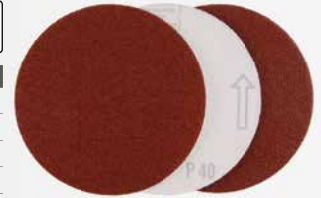

FESTA

WYCINKA WIBRACYJNA - 94 X 94 X 94 MM

N.p.	chropowość	
21831	P60	1
21832	P80	1
21834	P120	1

3x

N.p.	chropowość	
22096	P40	20
22097	P60	20
22098	P80	20
22099	P120	20

3x

N.p.	chropowość	
21810	P40	20
21811	P60	20
21812	P80	20
21813	P100	20
21814	P120	20



PAPIER ŚCIERNY 93 X 230 MM

5x

N.p.	chropowość	ilość otworów	
21740	P40	8	20
21741	P60	8	20
21742	P80	8	20
21743	P100	8	20
21744	P120	8	20

PAPIER ŚCIERNY 115 X 280 MM

5x

N.p.	chropowość	ilość otworów	
21750	P40	10	20
21751	P60	10	20
21752	P80	10	20
21753	P100	10	20
21754	P120	10	20



PŁÓTNO ŚCIERNE 230 X 280 MM

10x

N.p.	chropowość	
21732	P40	1
21734	P60	1
21735	P80	1
21736	P100	1
21737	P120	1

10x

PAPIER ŚCIERNY WODOODPORNY 230 X 280 MM

N.p.	chropowość	
21701	P60	1
21702	P80	1
21703	P100	1
21704	P120	1
21705	P150	1
21706	P180	1
21709	P240	1

10x

PAPIER ŚCIERNY 230 X 280 MM

N.p.	chropowość	
21715	P40	1
21716	P60	1
21717	P80	1
21718	P100	1
21719	P120	1
21720	P150	1
21721	P180	1
21724	P240	1

NEW



FESTA

UCHWYT
NA PAPIER ŚCIERNY

· Ø 150 mm



N.p.	specyfikacja	
22119		1

FESTA

UCHWYT
NA PAPIER ŚCIERNY

· szybki chwyt



N.p.	specyfikacja	
22067	170 x 70 mm	10

UCHWYT
NA PAPIER ŚCIERNY



N.p.	specyfikacja	
22075	210 x 105 mm	100
22076	160 x 85 mm	100

UCHWYT
NA PAPIER ŚCIERNY



N.p.	specyfikacja	
22077	125 x 68 mm	10

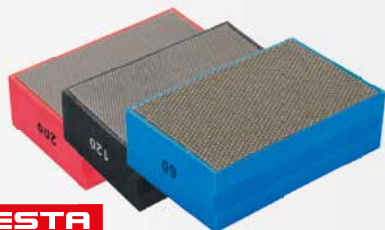

FESTA

DIAMENTOWA GĄBKA
ŚCIERNA

· 90 x 55 x 25 mm

- do płytki ceramiczne
- do szkło
- do marmur
- do granit



N.p.	chropowość	
22115	P60	10
22116	P120	10
22117	P200	10

ŚCIERNICA LISTKOWE
NA TRZPIENIU

N.p.	chropowość	specyfikacja	
21850	P40		1
21851	P60		1
21852	P80	20 x 20, Ø 6 mm	1
21853	P100		1
21854	P120		1
21855	P40		1
21856	P60		1
21857	P80	30x30, Ø 6mm	1
21858	P100		1
21859	P120		1
21860	P40		1
21861	P60		1
21862	P80	60x30, Ø 6mm	1
21863	P100		1
21864	P120		1



FESTA

GĄBKA SZLIFIERSKA
100 X 70 X 28 MM - ÚKOSNA



N.p.	chropowość	
22106	P 60	10
22107	P 80	10
22108	P 100	10
22109	P 120	10



FESTA

GĄBKA SZLIFIERSKA
100 X 70 X 25 MM



N.p.	chropowość	
22100	P60	20
22101	P80	20
22102	P100	20
22103	P120	20
22104	P180	20
22105	P220	20



FESTA

GĄBKA SZLIFIERSKA
120 X 95 X 10 MM



N.p.	chropowość	
22110	P80	20
22111	P120	20
22112	P180	20
22113	P220	20



FESTA

N.p.	specyfikacja	liczba zębó	
Ø 115 mm			
22300	Ø 115 x 22 mm	40	1
Ø 125 mm			
22301	Ø 125 x 22 mm	40	1
Ø 140 mm			
22302	Ø 140 x 20 mm	24	1
22303	Ø 140 x 20 mm	30	1
Ø 150 mm			
22305	Ø 150 x 20 mm	24	1
Ø 160 mm			
22307	Ø 160 x 20 mm	18	1
22309	Ø 160 x 20 mm	24	1
22310	Ø 160 x 20 mm	30	1
22311	Ø 160 x 20 mm	36	1
22312	Ø 160 x 20 mm	48	1
22313	Ø 160 x 20 mm	60	1
Ø 165 mm			
22314	Ø 165 x 20 mm	24	1
Ø 180 mm			
22315	Ø 180 x 30 mm	24	1
22317	Ø 180 x 30 mm	50	1
22318	Ø 180 x 20 mm	50	1
Ø 185 mm			
22316	Ø 185 x 20 mm	24	1
Ø 190 mm			
22319	Ø 190 x 20 mm	40	1
22320	Ø 190 x 30 mm	40	1
Ø 200 mm			
22322	Ø 200 x 30 mm	24	1
22324	Ø 200 x 30 mm	40	1
22326	Ø 200 x 30 mm	60	1
Ø 205 mm			
22328	Ø 205 x 30 mm	40	1
22329	Ø 205 x 30 mm	60	1
Ø 210 mm			
22332	Ø 210 x 30 mm	40	1
22333	Ø 210 x 30 mm	60	1
Ø 250 mm			
22335	Ø 250 x 30 mm	40	1
22337	Ø 250 x 30 mm	60	1
Ø 300 mm			
22340	Ø 300 x 30 mm	40	1
22343	Ø 300 x 30 mm	60	1
22345	Ø 300 x 30 mm	96	1
Ø 350 mm			
22350	Ø 350 x 30 mm	40	1
22351	Ø 350 x 30 mm	54	1
Ø 400 mm			
22355	Ø 400 x 30 mm	40	1
22357	Ø 400 x 30 mm	60	1
Ø 500 mm			
22365	Ø 500 x 30 mm	60	1
Ø 600 mm			
22370	Ø 600 x 30 mm	60	1

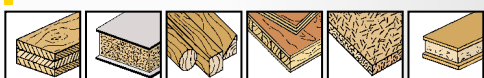
**FESTA****TARCZA DO DREWNA TCT****PIERŚCIEN ODLEGŁOŚCIOWY**

N.p.	specyfikacja	
22399	Ø 20 16 mm	1
22398	Ø 30 25 mm	1

FESTA

ZESTAW AKCESORIÓW DO OSCYLACYJNEGO NARZĘDZIA WIELOFUNKCYJNEGO

Do 28045



4x

3x BI-METAL



1x SK5

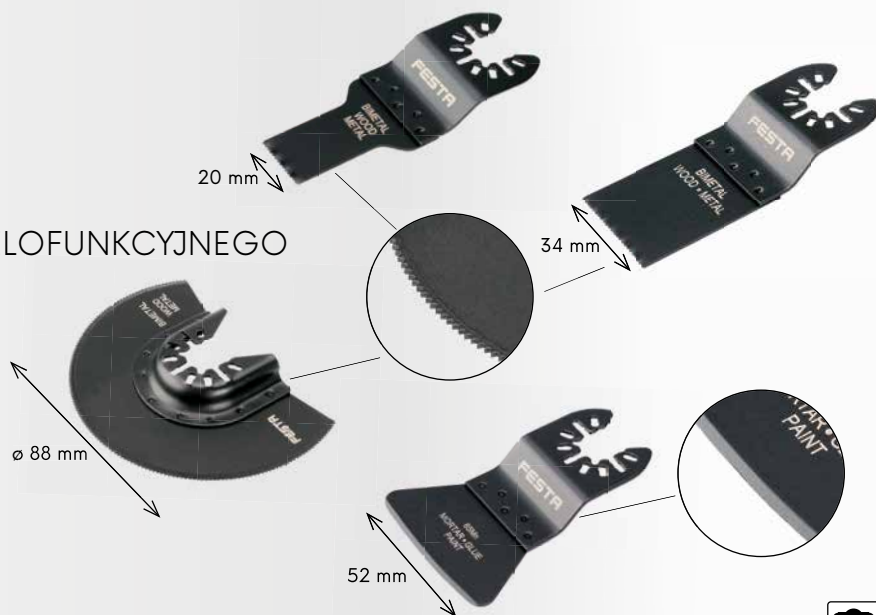

N.p. specyfikacja

24322



10

FESTA

ZESTAW AKCESORIÓW DO OSCYLACYJNEGO NARZĘDZIA WIELOFUNKCYJNEGO

Do 28045



4x

3x CARBIDE



1x



N.p. specyfikacja

24321



10

ZESTAW AKCESORIÓW DO OSCYLACYJNEGO NARZĘDZIA WIELOFUNKCYJNEGO

Do 28045



HCS 3x

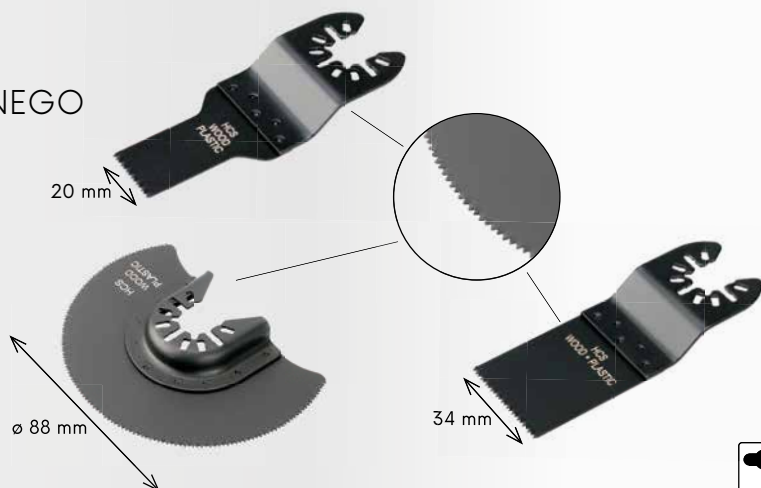

N.p. specyfikacja

24320



10

PROFESJONALNE BRZESZCZOTY
WYPRODUKOWANO W NIEMCZECH PRZY UŻYCIU TECHNOLOGII WYPALANIA LASEREM



BRZESZCZOT HSS – MOCOWANIE AEG, BOSCH, FESTO, MAKITA, METABO

	24060	50mm/1mm	0,7 mm/ 36TPI	31007	5 szt.	10	
	24061	50mm/1mm	1,2 mm/ 21TPI	31012	5 szt.	10	
	24062	50mm/1mm	2,0 mm/ 13TPI	31020	5 szt.	10	
	24063	75mm/1mm	3,0 mm/ 8TPI	31030	5 szt.	10	
	24064	100mm/1mm	1,2 mm/ 21TPI	31112	5 szt.	10	
	24065	100mm/1,3mm	2,0 mm/ 13TPI	31112	5 szt.	10	
	24066	75mm/1,45mm	2,0 mm/ 13TPI	31220	5 szt.	10	
	24067	120mm/1,3mm	1,8 - 2,4 mm/ 10 - 14 TPI	31220	5 szt.	10	
	24068	75mm/1,45mm	2,5 mm/ 10 TPI	32225	5 szt.	10	
	24069	75mm/1,45mm	4 mm/ 6 TPI	32240	5 szt.	10	
	24070	75mm/1,3mm	4 mm/ 6 TPI	32340	5 szt.	10	
	24071	75mm/1,3mm	4 mm/ 6 TPI	32440	5 szt.	10	
	24072	75mm/1,45mm	2,5 mm/ 10 TPI	32625	5 szt.	10	
	24073	85mm/1,45mm	3 mm/ 8 TPI	32730	5 szt.	10	
	24074	85mm/1,45mm	4 mm/ 6 TPI	32730	5 szt.	10	
	24075	75mm/1,45mm	2,5 1,2 mm/10 21 TPI	32825	5 szt.	10	
	24076	75mm/1,7mm	4 mm 6 TPI	32940	5 szt.	10	
	24077	120mm/1,3mm	4 mm 6 TPI	32040	5 szt.	10	
	24078	105mm/1,45mm	4 mm 6 TPI	34040	5 szt.	10	
	24055	55mm	karbid		5 szt.	1	

BRZESZCZOT HSS – MOCOWANIE BLACK & DECKER (BLACK & DECKER, SKIL)

	24080	50mm 1,0 mm	1,2 21 TPI	11012	5 szt.	10	
	24081	75mm 1,0 mm	3,0 8 TPI	11030	5 szt.	10	
	24082	75mm 1,45 mm	2,5 10 TPI	12225	5 szt.	10	
	24083	75mm 1,45 mm	4 6 TPI	12240	5 szt.	10	
	24084	75mm 1,3 mm	4 6 TPI	12340	5 szt.	10	
	24085	50mm 1,0 mm	2,0 13 TPI	12420	5 szt.	10	
	24086	75mm 1,3 mm	4,0 6 TP	12440	5 szt.	10	
	24087	75mm 1,45 mm	2,5 10 TPI	12625	5 szt.	10	

	miękka stal (z małą zawartością węgla)		blacha stalowa		stal nierdzewna		deski laminowane
	metale nieżelazne		twarde i miękkie drewno		plyta wiórowa		plastiki
	sklejka		sklejka		drewno z gwoździami		
	materiał sandwichowy		bruk		aluminium		

STOJAK NA BRZESZCZOTY

- przedmioty na stoisku 24098 - 24060 · 5 szt.
- 24080 · 5 szt.
- 24061 · 5 szt.
- 24062 · 5 szt.
- 24081 · 5 szt.
- 24063 · 5 szt.
- 24066 · 5 szt.
- 24067 · 5 szt.
- 24082 · 5 szt.
- 24068 · 5 szt.
- 24083 · 5 szt.
- 24069 · 5 szt.
- 24084 · 5 szt.
- 24070 · 5 szt.
- 24086 · 5 szt.
- 24071 · 5 szt.
- 24087 · 5 szt.
- 24072 · 5 szt.
- 24073 · 5 szt.
- 24074 · 5 szt.
- 24075 · 5 szt.
- 24076 · 5 szt.



ZESTAW BRZESZCZOTÓW



5x

N.p.	specyfikacja	
24045	zestaw	50

N.p.	specyfikacja	
24099	64 x 50 cm - stojak	1
24098	64 x 50 cm - zawiera ostrza	1

FESTA

BRZESZCZOT DO PIŁY SZABLASTEJ

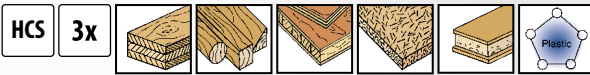

N.p. specyfikacja
24301 150 x 19 x 1,3 mm TPI 6



1

FESTA

BRZESZCZOT DO PIŁY SZABLASTEJ

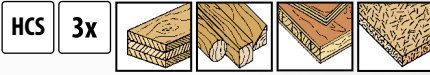

N.p. specyfikacja
24302 225 x 19 x 1,3 mm TPI 3



1

FESTA

BRZESZCZOT DO PIŁY SZABLASTEJ

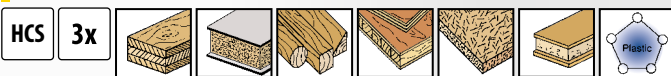

N.p. specyfikacja
24303 200 x 19 x 1,3 mm TPI 6 - 10



1

FESTA

BRZESZCZOT DO PIŁY SZABLASTEJ

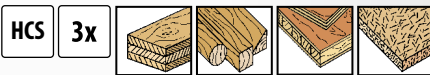

N.p. specyfikacja
24304 240 x 19 x 1,5 mm TPI 5



1

FESTA

BRZESZCZOT DO PIŁY SZABLASTEJ

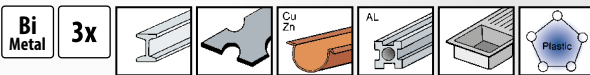

N.p. specyfikacja
24305 150 x 19 x 1 mm TPI 24

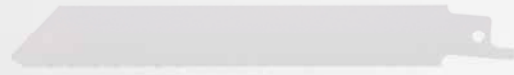

1

FESTA

BRZESZCZOT DO PIŁY SZABLASTEJ

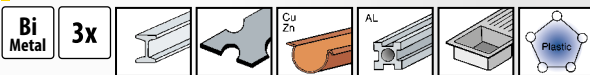

N.p. specyfikacja
24306 150 x 19 x 1 mm TPI 9



1

FESTA

BRZESZCZOT DO PIŁY SZABLASTEJ



N.p. specyfikacja
24308 225 x 19 x 1 mm TPI 10 - 14

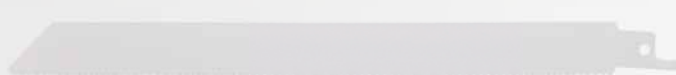

1

FESTA

BRZESZCZOT DO PIŁY SZABLASTEJ



N.p. specyfikacja
24310 150 x 22 x 1,6 mm TPI 9



1

FESTA

BRZESZCZOT DO PIŁY SZABLASTEJ



N.p.	specyfikacja	
24313	225 x 22 x 1,6 mm TPI 6	1

FESTA

BRZESZCZOT DO METALU

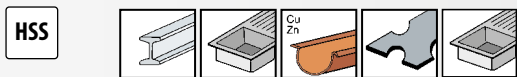

N.p.	specyfikacja	
24050	203 x 19 x 1 mm TPI 10 - 14	25

FESTA

BRZESZCZOT DO PIŁY SZABLASTEJ

· Technologia węgla

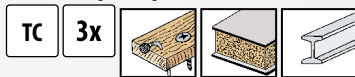

N.p.	specyfikacja	
24312	225 x 19 x 1,3 mm TPI 6 - 9	1

FESTA

BRZESZCZOT DO PIŁY SZABLASTEJ



N.p.	specyfikacja	
24315	305 x 50 x 1,5 mm	1
24316	455 x 50 x 1,5 mm	25

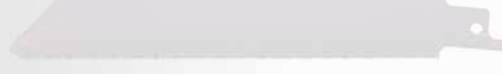
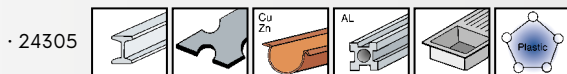

FESTA

BRZESZCZOT DO PIŁY SZABLASTEJ



N.p.	specyfikacja	
24314		1

FESTA

UCHWYT DO BRZESZCZOTÓW

· uchwyt + 2x brzeszczot
· do brzeszczotów pił szablanych



N.p.	specyfikacja	
24325		1





FESTA
INDUSTRY



PIŁA KABŁĄKOWA BRZESZCZOT

hartowane zęby



N.p.	specyfikacja	
24185	533 mm	1
24186	610 mm	1
24187	760 mm	1
24188	800 mm	1
24189	914 mm	1

FESTA

PIŁA KABŁĄKOWA BRZESZCZOT

hartowane zęby



N.p.	specyfikacja	
24169	350 mm	10
24167	450 mm	10
24166	533 mm	10
24163	610 mm	10
24164	760 mm	10
24168	800 mm	10
24165	914 mm	10



BRZESZCZOT



N.p.	specyfikacja	
24195	przęsło 3 mm 300 mm	1
24196	przęsło 4 mm 300 mm angled	1
24197	przęsło 5 mm 300 mm hardened	1
24192	pilový list do řeznické pily 450 mm	1

BRZESZCZOT



N.p.	specyfikacja	
24160	przęsło 3 mm 300 mm	20
24161	przęsło 4 mm 300 mm	20
24162	przęsło 5 mm 300 mm	50

BRZESZCZOT

10x



N.p.	specyfikacja	
24108	6 mm 150 mm	1

BRZESZCZOT WOLFRAMOWY



N.p.	specyfikacja	
24120	300 mm	50



FESTA

BRZESZCZOT BI - METAL

8 % COBALT



N.p.	specyfikacja	
24180	300 mm	125

FESTA

BRZESZCZOT



N.p.	specyfikacja	
24109	12,5 mm 300 mm do metalu	144
24118	25 mm 300 mm do metalu, dwustronna	72
24119	25 mm 300 mm do metalu i drewna	72





96

MIARA ZWIJANA



101

MIARKI SKŁADANE



104

LINIJKI I KĄTOMIERZE



106

POZIOMICA I ŁATA



112

LASERLINER



116

OŁÓWKI I MARKERY



120

SPRAY



122

NÓŻ, OSTRZE ŁAMANE



137

OBCINAK DO RUR PVC



140

WKRĘTAK



146

BITY



154

ZESTAW KLUCZY



159

NASADKA



164

KLUCZE PŁASKIE



169

SZCZYPCE



179

NOŻYCE DO BLACHY



182

NITOWNICA OBROTOWA



188

PILNIK



190

OPRAWKA DO METALU,
PIŁA PŁATNICA

195

MŁOTEK ŚLUSARSKI



203

ŚCISK

NARZĘDZIA WARSZTATOWE 94 - 205



KOMELON®

· WYSOKIE POMIARY SZCZEGÓLNE I JAKOŚCI

- II. klasa dokładności wg ČSN 251104, EEC 755345
- nowe nylonowe pokrycie pasu DURA NY Coat zapewnia 10x większą odporność skali na ścieranie się

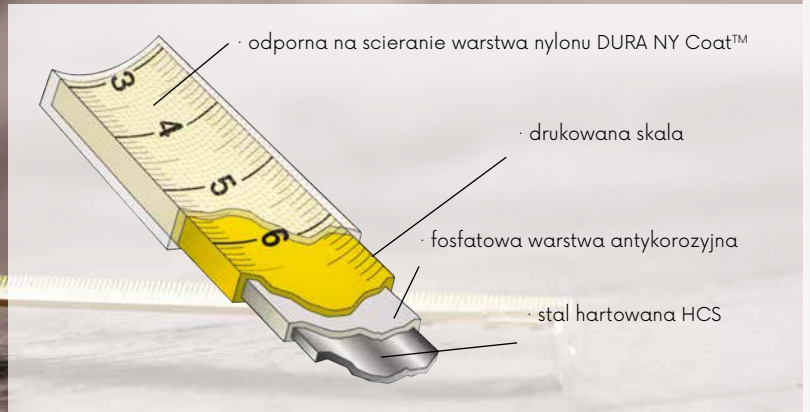

· Odporność na ścieranie nylonem powłoki DURA NY Coat™

KOMELON® MIARA ZWIJANA



N.p.	specyfikacja	
10002	2 m · 16 mm	10
10003	3 m · 16 mm	10
10005	5 m · 19 mm	10
10008	8 m · 25 mm	10



· Odporność na ścieranie nylonem powłoki DURA NY Coat™

KOMELON® MIARA ZWIJANA



N.p.	specyfikacja	
10025	5 m · 25 mm	10



· Odporność na ścieranie nylonem powłoki DURA NY Coat™

KOMELON® MIARA ZWIJANA

· automatyczny hamulec

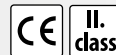

N.p.	specyfikacja	
10033	3 m · 16 mm	6
10035	5 m · 19 mm	6



KOMELON® MIARA ZWIJANA



N.p.	specyfikacja	
10043	3 m · 16 mm	30
10045	5 m · 19 mm	30
10048	8 m · 25 mm	12



KOMELON® MIARA ZWIJANA SWING TAŚMA STALOWA

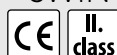

N.p.	specyfikacja	
10110	10 m · 10 mm	6
10120	20 m · 10 mm	6
10130	30 m · 10 mm	6



KOMELON® MIARA ZWIJANA NEO TAŚMA WŁÓKNO SZKLANE



N.p.	specyfikacja	
10330	10 m · 13 mm	6
10332	20 m · 13 mm	6
10334	30 m · 13 mm	6
10336	50 m · 13 mm	6



KOMELON®

MIARA ZWIJANA UNIGRIP
TAŚMA WŁÓKNO SZKLANE



N.p.	specyfikacja	
10430	30 m · 13 mm	1
10450	50 m · 13 mm	1
10490	100 m · 13 mm	1



· zdjęcie ilustracyjne

STOISKO PROMOCYJNE

N.p.	specyfikacja	
10998		1

KOMELON®
STOISKO PROMOCYJNE

· przedmioty na stoisku 10996

10003	5 szt.
10005	4 szt.
10008	1 szt.
10033	2 szt.
10035	3 szt.
10045	2 szt.
10025	3 szt.
10110	1 szt.
10120	1 szt.
10130	1 szt.
10430	1 szt.
10330	1 szt.
10332	1 szt.
10334	1 szt.
10336	1 szt.



· zdjęcie ilustracyjne

N.p.	specyfikacja	
10999	stojak na miarki zwijane	1
10996	stojak wypełniony przedmiotami	1



· informacje o taśmie mierniczej



· długość taśmy mierniczej



· klasa dokładności



· deklaracja zgodności- CE



· rok produkcji



· numer akredytowanej jednostki certyfikującej wydającej certyfikat



· producent



· specjalne wykończenie taśmy mierniczej



· temperaturą, w której przeprowadzono test

FESTA



FESTA

MIARA ZWIJANA

- skala z dużymi cyframi
- antypoślizgowe gumowanie
- warstwa nylonu

N.p.	specyfikacja		
11353	3 m · 19 mm	12	
11355	5 m · 19 mm	12	
11356	5 m · 25 mm	12	
11358	8 m · 25 mm	6	
11360	10 m · 25 mm	6	



FESTA

MIARA ZWIJANA

- warstwa nylonu
- obudowa Abs
- chromowany metalowy klips
- automatyczny hamulec
- antypoślizgowe gumowanie PTE
- petla

N.p.	specyfikacja		
11343	3 m · 16 mm	6	
11345	5 m · 19 mm	6	
11347	7,5 m · 25 mm	6	



FESTA

MIARA ZWIJANA - MAGNET

- 3 x hamulec
- haczyk magnetyczny
- przytrzymaj taśmie
- antypoślizgowe gumowanie

N.p.	specyfikacja		
11323	3 m · 19 mm	10	
11325	5 m · 25 mm	10	
11327	7,5 m · 25 mm	6	



FESTA

MIARA ZWIJANA MAGNETIC

- haczyk magnetyczny
- antypoślizgowe gumowanie
- taśma fluorescencyjna
- skala z dużymi cyframi

N.p.	specyfikacja		
11102	2 m · 16 mm	10	
11103	3 m · 16 mm	10	
11105	5 m · 19 mm	12	
11106	5 m · 25 mm	12	
11107	7,5 m · 25 mm	10	
11110	10 m · 25 mm	6	



FESTA

MIARA ZWIJANA

- skala z dużymi cyframi

N.p.	specyfikacja	
11226	2 m · 16 mm	10
11239	3 m · 19 mm	10
11259	5 m · 19 mm	12
11260	7,5 m · 25 mm	6



FESTA

MIARA ZWIJANA

- automatyczny hamulec
- antypoślizgowe gumowanie

N.p.	specyfikacja	
11333	3 m · 16 mm	12
11335	5 m · 19 mm	12
11337	7,5 m · 25 mm	6
11338	10 m · 25 mm	6



FESTA

MAŁA TAŚMA MIERNICZA

- mały rozmiar taśmy
- warstwa nylonu

N.p.	specyfikacja		
11220	3 m · 16 mm	12	
11221	5 m · 19 mm	12	



Johnney®

MIARA ZWIJANA

· matowa powierzchnia taśmy

II. class



N.p.	specyfikacja	
11002	2 m · 13 mm	12
11003	3 m · 13 mm	12
11005	5 m · 13 mm	12
11006	5 m · 19 mm	12
11007	7,5 m · 19 mm	12
11008	10 m · 25 mm	12



MIARA ZWIJANA - ERGO

· przytrzymaj tasme
· antypoślizgowe gumowanie



N.p.	specyfikacja	
11082	2 m · 16 mm	12
11083	3 m · 16 mm	12
11085	5 m · 19 mm	12



MIARA ZWIJANA

· traka cm/inc
· antypoślizgowe gumowanie



N.p.	specyfikacja	
11416	5 m · 19 mm	10



MIARA ZWIJANA

· przytrzymaj tasme



N.p.	specyfikacja	
11200	2 m · 13 mm	24
11201	2 m · 16 mm	24
11202	2 m · 19 mm	24
11204	3 m · 13 mm	24
11205	3 m · 16 mm	24
11206	3 m · 19 mm	24
11207	5 m · 19 mm	12
11208	5 m · 25 mm	12
11209	7,5 m · 25 mm	12
11210	10 m · 25 mm	12

MIARA ZWIJANA Z IMIENIEM, 3M · 16 MM

CE II. class

Č.p.	jméno na metru	Č.p.	jméno na metru	Č.p.	jméno na metru	Č.p.	jméno na metru
13500	JIŘÍ	13509	MIROSLAV	13518	VÁCLAV	13527	MISTR
13501	PETR	13510	BIG BOSS	13519	JAKUB	13528	ONDŘEJ
13502	JOSEF	13511	ZDENĚK	13520	LUKÁŠ	13529	MAREK
13503	TOMÁŠ	13512	MICHAL	13521	2X MĚŘ	13530	STANISLAV
13504	JAN	13513	MILAN	13522	LADISLAV	13531	BOREC
13505	MARTIN	13514	KAREL	13523	DAVID	13532	TATÍNEK
13506	JAROSLAV	13515	VLADIMÍR	13524	ROMAN	13533	ANTONÍN
13507	FRANTIŠEK	13516	DĚDEČEK	13525	ŠIKULA	13534	ALEŠ
13508	PAVEL	13517	MŮJ METR	13526	RADEK		



10



FESTA

MIARA ZWIJANA TAŚMA STAŁOWA

· petla

CE II. class



N.p.	specyfikacja	
12010	10 m · 10 mm	1
12020	20 m · 10 mm	1
12030	30 m · 10 mm	1
12050	50 m · 10 mm	6



FESTA

MIARA ZWIJANA TAŚMA WŁÓKNO SZKLANE

· petla

CE II. class



N.p.	specyfikacja	
12110	10 m · 13 mm	6
12120	20 m · 13 mm	1
12130	30 m · 13 mm	1
12150	50 m · 13 mm	1



FESTA

MIARA ZWIJANA TAŚMA STAŁOWA

· petla + haczyk

CE II. class



N.p.	specyfikacja	
12220	20 m · 10 mm	6
12230	30 m · 10 mm	6
12250	50 m · 10 mm	6



FESTA

MIARA ZWIJANA STALOWA

· petla



N.p.	specyfikacja	
12433	30 m · 12,5 mm	20
12435	50 m · 12,5 mm	10



KÓŁKO POMIAROWE

- wytrzymałe, lekkie i kompaktowe
- licznik liczy podczas ruchu do przodu i odejmuje podczas ruchu w tył
- wbudowane oświetlenie nocne, w uchwycie 2 baterie aaa
- torba



N.p.	specyfikacja	
15989	max. 10 km	2



FESTA

MIARA TELESKOPOWA

· torba

N.p.	specyfikacja	
15983	0,7 - 3 m	10
15985	1,1 - 5 m	10
15988	1,6 - 8 m	5



SAMOPRZYLEPNA TAŚMA MIERNICZA



N.p.	specyfikacja	
11311	1 m · 12,5 mm	30
11312	2 m · 12,5 mm	30
11313	3 m · 16 mm	30
11314	5 m · 19 mm	30



MIARKA BRELOCZEK

N.p.	specyfikacja	
11420	1 m · 6 mm pomarańczowy	24



FESTA

MIARKA BRELOCZEK

- skala z dużymi cyframi
- właściwości klasycznej taśmy mierniczej



N.p.	specyfikacja	
11410	2 m · 16 mm 6 kolor	12



MIARKA BRELOCZEK

N.p.	specyfikacja	
11444	1 m · 6 mm biały	20



MIARKA BRELOCZEK

N.p.	specyfikacja	
11425	1 m · 6 mm	25



BRELOCZEK LIBELLA

N.p.	specyfikacja	
11445		100

MIARKI SKŁADANE - DREWNIANE



N.p.	specyfikacja	
13010	1 m · biały	20
13020	2 m · biały	10
13021	1 m · żółty	20
13022	2 m · żółty	10
13023	2 m · biało - żółty	10

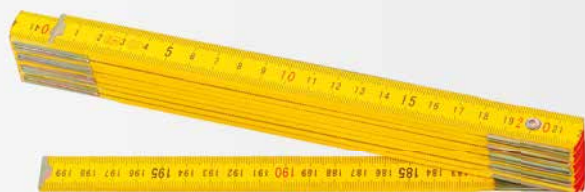

MIARKI SKŁADANE - DREWNIANE



N.p.	specyfikacja	
13111	1 m · żółty	10
13120	2 m · żółty	5

MIARKI SKŁADANE



N.p.	specyfikacja	
13211	1 m	1
13220	2 m	1



MIARKI SKŁADANE - DREWNIANE Z IMIENIEM



N.p.	jmie	N.p.	jmie		
13401	JIRÍ	13426	DANIEL	10	
13402	JAN	13427	ANTONÍN		
13403	PETR	13428	VOJTĚCH	13451	JANA
13404	JOSEF	13429	FILIP	13452	EVA
13405	PAVEL	13430	ADAM	13453	PETRA
13406	MARTIN	13431	MILOSLAV	13454	MAJKA
13407	JAROSLAV	13432	MATĚJ	13455	HANA
13408	TOMÁŠ	13433	ALEŠ	13456	ANNA
13409	MIROSLAV	13434	JAROMÍR	13457	LENKA
13410	ZDENĚK	13435	LIBOR	13458	KATKA
13411	FRANTIŠEK	13436	DOMINIK	13459	LUCIE
13412	VÁCLAV	13437	PATRIK	13460	ALENA
13413	MICHAL	13438	VLASTIMIL	13461	VERONIKA
13414	MILAN	13439	JINDŘICH	13462	MARTINA
13415	KAREL	13440	MILOŠ	13463	JITKA
13416	JAKUB	13441	JÁN	13464	BIG BOSS
13417	LUKÁŠ	13442	PETER	13465	2 x MĚŘ
13418	DAVID	13443	ONDREJ	13466	TATÍNEK
13419	VLADIMÍR	13444	JOZEF	13467	DĚDEČEK
13420	LADISLAV	13445	PAVOL	13468	ŠIKULA
13421	ONDŘEJ	13446	L'UBOMÍR	13469	MISTR
13422	ROMAN	13447	KAROL	13470	MACHR
13423	STANISLAV	13448	RADOSLAV	13471	BOREC
13424	MAREK	13449	VOJTĚCH	13472	UŽ JE MŮJ
13425	RADEK	13450	ZDENKO	13473	MŮJ METR

STOJAK NA MIARKI SKŁADANE

· przedmioty na stoisku 13399

- 13401 · 15 szt.
- 13402 · 15 szt.
- 13403 · 15 szt.
- 13404 · 15 szt.
- 13405 · 15 szt.
- 13406 · 15 szt.
- 13412 · 15 szt.
- 13413 · 15 szt.
- 13414 · 15 szt.
- 13415 · 15 szt.
- 13416 · 15 szt.
- 13417 · 15 szt.
- 13418 · 15 szt.
- 13419 · 15 szt.
- 13420 · 15 szt.
- 13421 · 10 szt.
- 13422 · 10 szt.
- 13423 · 10 szt.
- 13424 · 10 szt.
- 13425 · 10 szt.
- 13426 · 10 szt.
- 13427 · 10 szt.
- 13428 · 10 szt.
- 13429 · 10 szt.
- 13430 · 10 szt.
- 13431 · 10 szt.
- 13432 · 10 szt.
- 13433 · 10 szt.
- 13434 · 10 szt.
- 13435 · 10 szt.
- 13436 · 10 szt.
- 13437 · 10 szt.
- 13438 · 10 szt.
- 13439 · 10 szt.
- 13440 · 10 szt.



N.p.	specyfikacja	
13399	stojak wypełniony przedmiotami	1
13400	stać bez przedmiotów	1



FESTA

SUWMIARKA CYFROWA



INOX	N.p.	specyfikacja	
	14007	150 0,01 mm	10
	14008	200 0,01 mm	10
	14009	300 0,01 mm	10

SUWMIARKA CYFROWA

· dokładność 0,2 mm, resolution 0,1 mm

N.p.	specyfikacja	
14013	150 0,2 mm	10

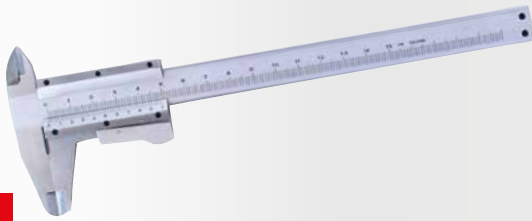

FESTA

SUWMIARKA INOX



INOX	N.p.	specyfikacja	
	14004	150 0,02 mm	10

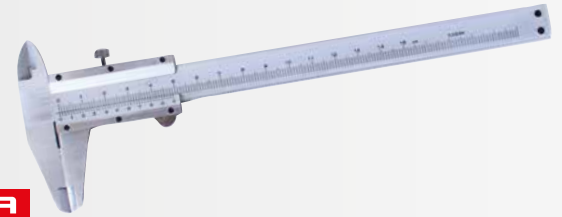

FESTA

SUWMIARKA INOX



INOX	N.p.	specyfikacja	
	14001	150 0,02 mm	10
	14002	200 0,02 mm	10
	14003	300 0,02 mm	10



FESTA

MIKROMETR ZEWNĘTRZNY



N.p.	specyfikacja	
14040	0 - 0,25 0,01 mm	10
14045	25 - 50 0,01 mm	10



SUWMIARKA

HOBBY

PLASTIC	N.p.	specyfikacja	
	14006	150 mm	50



FESTA

MIERNIK ODCHYLEK



INOX	N.p.	specyfikacja	
	14035	0 - 10mm 0,01 mm	10



SZCZELINOMIERZ

· 20 blaszek



N.p.	specyfikacja	
14080	0,05 - 1 mm	10



CYRKIEL



N.p.	specyfikacja	
13285	200 mm	10



FESTA

RYSIK WĘGLIKOWY



N.p.	specyfikacja	
13281	150 mm	50



FESTA

RYSIK WĘGLIKOWY



N.p.	specyfikacja	
13282	200 mm	50

FESTA

LINIJKĄ Z RĄCZKĄ

ALU		
N.p.	specyfikacja	
14030	600 mm	6

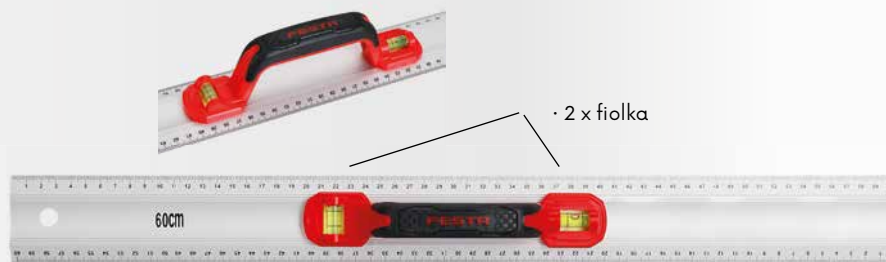

FESTA

LINIJKĄ ALU

ALU		
N.p.	specyfikacja	
14015	400 mm	48
14017	600 mm	50
14019	1000 mm	40



FESTA

LINIJKĄ ZE STALI NIERDZEWNEJ

INOX		
N.p.	specyfikacja	
14010	300 mm	10
14011	600 mm	10
14012	1000 mm	10

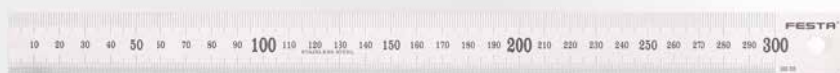

FESTA

KĄTOMIERZ Z OBROTOWYM RAMIENIEM

· torba

N.p.	specyfikacja	
14060	0° - 180° · 150 x 200 mm	10
14070	0° - 180° · 300 x 500 mm	5

KĄTOMIERZ

HOBBY		
N.p.	specyfikacja	
14075	0° - 180° · 230 x 500 mm	30



UNIWERSALNA LINIJKĄ

ALU		
No.	Specification	
14077		10



UNIWERSALNA LINIJKA



N.p.	specyfikacja	
14480	250 x 120 mm	1



zablokować

SZABLON DO KOPIOWANIA Kształtów



N.p.	specyfikacja	
14090	125 x 30 mm	1
14091	250 x 30 mm	1

FESTA

KĄTOWNIK 3D



N.p.	specyfikacja	
14418		10



FESTA

KĄTOWNIK



N.p.	specyfikacja	
14420	180 mm	10
14421	300 mm	10

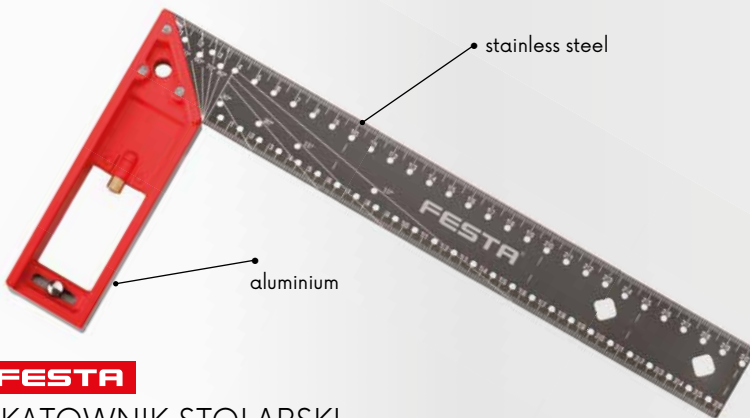

FESTA

KĄTOWNIK STOLARSKI



No.	Specification	
14415	300 mm	6
14417	400 mm	6



FESTA

KAŹTOWNIK

ALU



N.p.	specyfikacja	
14445	600 x 600 mm	1
14446	1200 x 1200 mm	1



FESTA

KAŹTOWNIK

ALU



N.p.	specyfikacja	
14450	190 x 355 mm	6
14451	200 x 405 mm	6

FESTA

KAŹTOWNIK STOLARSKI



N.p.	specyfikacja	
14220	200 x 125 mm	10
14225	250 x 135 mm	10
14230	300 x 135 mm	10
14235	350 x 190 mm	10
14240	400 x 190 mm	10
14250	500 x 210 mm	10

FESTA

KAŹTOWNIK STOLARSKI



N.p.	specyfikacja	
14350	500 x 235 mm	10
14360	600 x 300 mm	10
14370	700 x 300 mm	10
14380	800 x 320 mm	10
14399	1000 x 360 mm	10



KAŹTOWNIK

N.p.	specyfikacja	
14410	300 x 200 mm	50
14411	600 x 400 mm	36

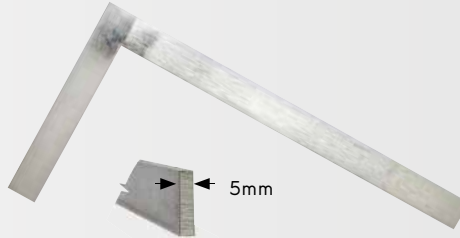

KAŹTOWNIK PŁASKI
OCYNK

Zn

N.p.	specyfikacja	
14471	150 x 100 mm	25
14472	250 x 125 mm	25
14473	400 x 200 mm	30
14474	600 x 300 mm	25

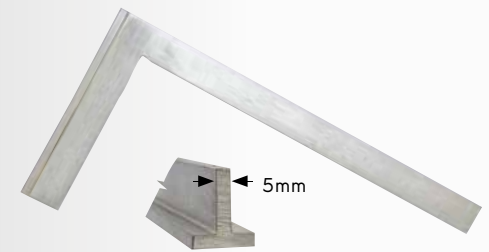

KAŹTOWNIK ZE STOPKĄ
OCYNK

Zn

N.p.	specyfikacja	
14490	100 x 50 mm	10
14491	150 x 75 mm	10
14492	250 x 125 mm	10
14493	400 x 200 mm	10
14494	600 x 300 mm	10



KAŹTOWNIK

N.p.	specyfikacja	
14455	300 x 200 mm	50
14456	500 x 250 mm	50
14457	700 x 300 mm	40
14458	1000 x 450 mm	30



KAŹTOWNIK

ALU HOBBY

N.p.	specyfikacja	
14425	250 x 130 mm	12
14430	300 x 130 mm	12
14435	350 x 156 mm	12
14440	400 x 156 mm	12



SKOS KAŹTOWNIK



N.p.	specyfikacja	
14025	255 x 285 mm	1

MADE IN EUROPE

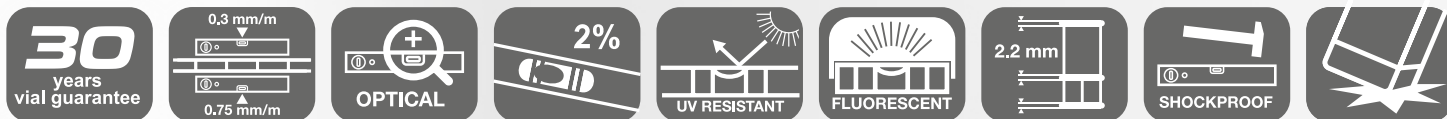

Każda sztuka jest testowana elektronicznie i ma swój numer dowodowy, producent jest posiadaczem certyfikatu ISO 90001



HORIZONT
MASTER



HORIZONT

POZIOMICA MASTER - 2 LIBELLE

ALU

N.p.	specyfikacja	
15033	60 cm	10



HORIZONT

POZIOMICA MASTER - 3 LIBELLE

ALU

N.p.	specyfikacja	
15034	80 cm	10
15035	100 cm	10



HORIZONT

POZIOMICA MASTER - 3 LIBELLE I UCHWYTY

ALU

N.p.	specyfikacja	
15036	120 cm	10
15037	150 cm	10
15039	200 cm	10

HORIZONT®

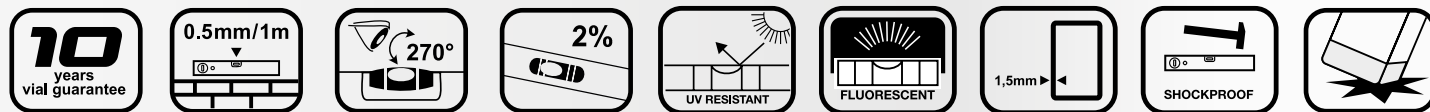

Każda sztuka jest testowana elektronicznie i ma swój numer dowodowy, producent jest posiadaczem certyfikatu ISO 90001

HORIZONT®

POZIOMICA - 2 LIBELLE



N.p.	specyfikacja	
15003	30 cm	30
15004	40 cm	30
15005	50 cm	30
15006	60 cm	30
15008	80 cm	30
15010	100 cm	30
15012	120 cm	10
15015	150 cm	10
15018	180 cm	10
15020	200 cm	10



HORIZONT®

POZIOMICA - 3 LIBELLE



N.p.	specyfikacja	
15103	30 cm	30
15104	40 cm	30
15105	50 cm	30
15106	60 cm	30
15108	80 cm	30
15110	100 cm	30
15112	120 cm	10
15115	150 cm	10
15118	180 cm	10
15120	200 cm	10



HORIZONT®

POZIOMNICA - 2 LIBELLE Z MAGNESAMI



N.p.	specyfikacja	
15204	40 cm	30
15205	50 cm	30
15206	60 cm	30
15208	80 cm	30
15210	100 cm	30
15212	120 cm	10
15215	150 cm	10
15218	180 cm	10
15220	200 cm	10



HORIZONT®

POZIOMNICA DO POMIARU KĄTA NACHYLENIA 4 LIBELLE



N.p.	specyfikacja	
15230	80 cm	10



HORIZONT

PRZYRZĄD DO POMIARU KĄTA NACHYLENIA

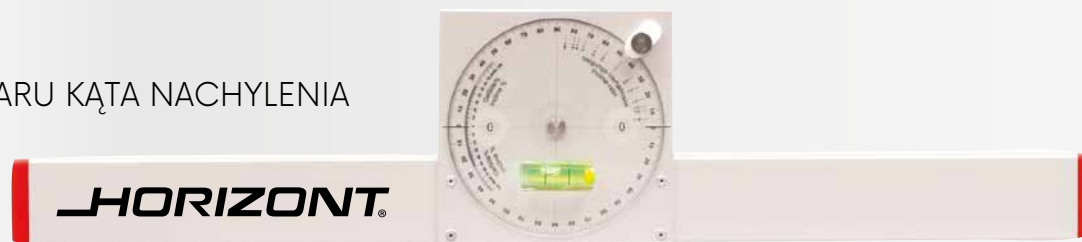

N.p.	specyfikacja	
15235	60 cm	1

**HORIZONT**

ŁATA - BEZ LIBELLI

ALU

N.p.	specyfikacja	
15310	100 cm	10
15315	150 cm	10
15318	180 cm	10
15320	200 cm	10
15325	250 cm	10
15330	300 cm	10
15335	350 cm	10
15340	400 cm	10

**HORIZONT**

ŁATA - 1 LIBELLA

ALU

N.p.	specyfikacja	
15415	150 cm	10
15418	180 cm	10
15420	200 cm	10
15425	250 cm	10
15430	300 cm	10

**HORIZONT**

ŁATA - 2 LIBELLE

ALU

N.p.	specyfikacja	
15510	100 cm	10
15515	150 cm	10
15518	180 cm	10
15520	200 cm	10
15525	250 cm	10
15530	300 cm	10
15535	350 cm	10
15540	400 cm	5

**HORIZONT**

ŁATA - BEZ LIBELLI Z UCHWYTAMI

ALU

N.p.	specyfikacja	
15615	150 cm	10
15620	200 cm	10
15625	250 cm	10
15630	300 cm	10



HORIZONT.

ŁATA - 2 LIBELLE I UCHWYTY

ALU

N.p.	specyfikacja	
15710	100 cm	10
15715	150 cm	10
15720	200 cm	10
15725	250 cm	10
15730	300 cm	10
15735	350 cm	10
15740	400 cm	5



HORIZONT.

ŁATA - PROFIL TRAPEZOWY

PROFIL TRAPEZOWY

- profil trapezowy służy do lepszego wykończenia powierzchni
- nadaje się do sztukaterii i fasad
- nadaje się do tynków cienkowarstwowych

ALU

N.p.	specyfikacja	
15810	100 cm	10
15812	120 cm	10
15815	150 cm	10
15818	180 cm	10
15820	200 cm	10
15825	250 cm	10
15830	300 cm	10



HORIZONT.

ŁATA - PROFIL H

PROFIL "h"

- profil "h" służy do lepszego wykończenia powierzchni
- nadaje się do sztukaterii i fasad
- nadaje się do tynkowania sufitów

ALU

N.p.	specyfikacja	
15850	100 cm	10
15853	150 cm	10
15855	180 cm	10
15860	200 cm	10
15870	250 cm	10
15880	300 cm	10

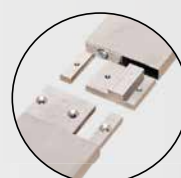

NEW

HORIZONT.

SPRZĘGŁO DLA LATÓW HORIZONT

N.p.	specyfikacja		
15301		1	



HORIZONT.

ŁATA - 1 LIBELLA REGULOWANA

N.p.	specyfikacja	
15893	65 - 100 cm	1
15894	95 - 150 cm	1
15895	145 - 235 cm	1



HORIZONT.

KAŻTOWNIK

ALU

N.p.	specyfikacja	
14485	800 x 1200 mm	1
14486	1000 x 1500 mm	1



HORIZONT.
STOJAK NA POZIOMNICE PION

· przedmioty na stoisku 15998

- 15003 · 5 szt.
- 15004 · 5 szt.
- 15005 · 5 szt.
- 15006 · 5 szt.
- 15008 · 5 szt.
- 15010 · 5 szt.
- 15012 · 5 szt.
- 15015 · 3 szt.
- 15018 · 3 szt.
- 15020 · 3 szt.
- 15108 · 3 szt.
- 15206 · 3 szt.
- 15210 · 3 szt.

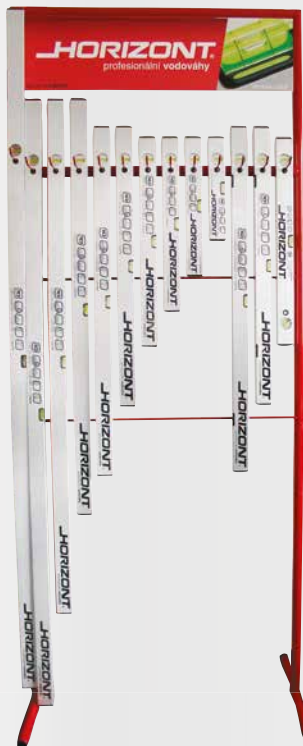

HORIZONT.
STOJAK NA POZIOMNICE PION

· przedmioty na stoisku 15996

- 15004 · 5 szt.
- 15005 · 5 szt.
- 15006 · 5 szt.
- 15008 · 5 szt.
- 15010 · 5 szt.
- 15012 · 5 szt.
- 15015 · 5 szt.
- 15018 · 5 szt.
- 15020 · 5 szt.
- 15315 · 2 szt.
- 15320 · 2 szt.
- 15325 · 3 szt.
- 15515 · 2 szt.
- 15520 · 2 szt.
- 15525 · 3 szt.



N.p.	specyfikacja	
15999	85 x 210 x 50 cm	1
15998	85 x 210 x 50 cm wypełnione przedmiotami	1

N.p.	specyfikacja	
15997	55 x 75 x 40 cm	1
15996	55 x 75 x 40 cm wypełnione przedmiotami	1

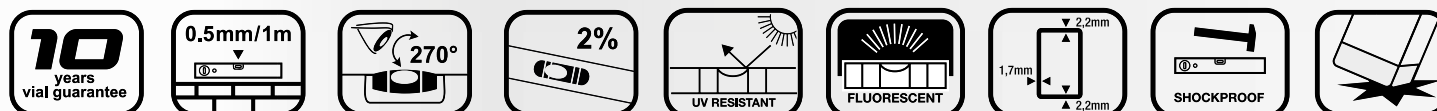

FESTA
POZIOMNICA
3 LIBELLE



N.p.	specyfikacja	
15754	400 mm	1
15756	600 mm	1
15758	800 mm	1
15760	1000 mm	1
15762	1200 mm	1
15768	1800 mm	1
15770	2000 mm	1



NEW



POZIOMNICA NIVELA 2 LIBELLE

- dokładność 0,5 mm | 1 m
- uv stabilny płyn libelli
- gumowe końcówki odporne na wstrząsy
- grubość powłoki 1,2 mm



N.p.	specyfikacja	
15904	40 cm	30
15906	60 cm	30
15908	80 cm	30
15910	100 cm	30
15912	120 cm	20
15915	150 cm	10
15920	200 cm	20



POZIOMNICA NIVELA 3 LIBELLE



N.p.	specyfikacja	
15954	40 cm	60
15956	60 cm	60
15958	80 cm	60
15960	100 cm	30
15962	120 cm	30
15965	150 cm	30
15970	200 cm	30



POZIOMNICA DO SŁUPKÓW



N.p.	specyfikacja	
15981		1



N.p.	specyfikacja	
15980	230 mm	1

POZIOMNICA Z MAGNESEM 3 LIBELLE

POZIOMNICA DO SŁUPKÓW

- 3 libelki, magnesy, pasek mocujący



N.p.	specyfikacja	
26028		12



POZIOMNICE WODNE



N.p.	specyfikacja	
15992	szklane rurki - wąż 10 m	1
15993	szklane rurki - wąż 15 m	1
15990	szklane rurki	50
15991	plastikowe rurki	50



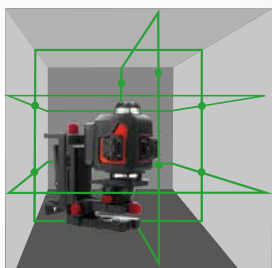

NEW

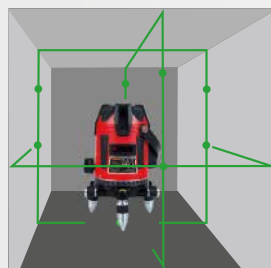

NEW



FESTA

LASER ALL LINE GREEN 4 X 360 °

- 2x płaszczyzna pozioma + 2x płaszczyzna pionowa (zielona wiązka)
- zakres samopoziomowania $\pm 4^\circ$
- dokładność: 0,2 mm/m
- wewnątrz 30 m, z odbiornikiem laserowym do 50 m
- tryb pulsacyjny – zalecany odbiornik dodatkowy 26209
- w zestawie: walizka transportowa, pilot zdalnego sterowania, celownik laserowy, Akumulator litowo-jonowy 5200 mAh, profesjonalny uchwyt, mini statyw, ładowarka

$\pm 4^\circ$	max. 50 m	± 0.2 mm/m	II. class	515 nm
1/4"	5/8"	IP54	Li-ion 3.7V 5.2Ah	

N.p. specyfikacja

26205



1



FESTA

LASER KRZYŻOWY ZIELONY

- 1x płaszczyzna pozioma + 4x płaszczyzna pionowa (zielona wiązka) + 1x punkt
- zakres samopoziomowania $\pm 3^\circ$
- dokładność: 0,2 mm/m
- wewnątrz 20 m, z odbiornikiem laserowym do 50 m
- tryb pulsacyjny – zalecany odbiornik dodatkowy 26209
- w zestawie: walizka transportowa, celownik laserowy, Akumulator litowo-jonowy 5200 mAh, profesjonalny uchwyt, mini statyw, ładowarka

$\pm 3^\circ$	max. 50 m	± 0.2 mm/m	II. class	515 nm
5/8"	IP54	Li-ion 3.7V 5.2Ah		

N.p. specyfikacja

26203



1

FESTA



FESTA

LASER ALL LINE GREEN 3 X 360 °

- 1x płaszczyzna pozioma + 2x płaszczyzna pionowa (wiązka zielona)
- zakres samopoziomowania $\pm 4^\circ$
- grubość 0,2 mm/m
- wewnętrzna: 30 m, zewnętrzna z czujnikiem 50 m
- tryb pulsacyjny – zalecany odbiornik oglądający 26209
- w zestawie: futerał, 4xAA baterie alkaliczne, celownik laserowy, gogle, akumulator litowo-jonowy 2600 mAh, profesjonalny uchwyt, urządzenie, podstawka akumulatora litowo-jonowego

$\pm 4^\circ$	INDOOR 30 m OUTDOOR 50 m	± 0.2 mm/m	II. class	515 nm
IP54	5/8"	1/4"	4x AA	Li-Ion 7.4V 2.6Ah



N.p. specyfikacja
26204 green

1



FESTA

LASER KRZYŻOWY ZIELONY

- 1x płaszczyzna pozioma + 1x płaszczyzna pionowa (wiązka zielona)
- zakres samopoziomowania $\pm 3^\circ$
- grubość 0,2 mm/m
- wewnętrzna: 20 m, zewnętrzna z czujnikiem 50 m
- tryb pulsacyjny – zalecany odbiornik oglądający 26209
- w zestawie: futerał, baterie alkaliczne 2xAA, uchwyt

$\pm 3^\circ$	INDOOR 20 m OUTDOOR 50 m	± 0.2 mm/m	II. class	515 nm
IP54	1/4"	2x AA		

N.p. specyfikacja
26201 green

1

FESTA

DALMIERZ

- zakres pomiarowy 0,05 - 50 m
- Pomiar pomiaru ± 2 mm, jednostka miary mm/in/ft
- pomiar ciągły, pomiar powierzchni, pomiar objętości, pomiar nóg trójkąta, LCD FSTN, dodawanie/odejmowanie, maks./min. pomiar, max pamięć 100 jednostek, podświetlenie, laser klasa 630-670 nm klasa 2
- temperatura pracy 0 - 40°C
- wymiary 112 x 50 x 25 mm, waga 90 g
- zawiera: futerał, 2 baterie alkaliczne AAA

max 50 m	± 2 mm	m in ft	630 670 nm
IP54	2x AAA		

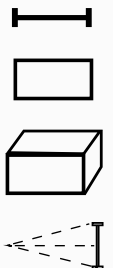

N.p. specyfikacja
26211

1



FESTA

ODBIORNIK LASEROWY

- do użytku z pulsacyjnymi urządzeniami laserowymi w celu zwiększenia wydajności do 50 m
- zawiera: 9 V, uchwyt
- dla 26201, 26203, 26204, 26205

max 50 m	±1.5 mm 10 m	5 kHz	IP54	1x 9V
--------------------	------------------------	--------------	-------------	--------------



N.p.	specyfikacja	
26209	range: 50 m	1

1/4" + 5/8"



60 - 150 cm

STATYW

ALU



N.p.	specyfikacja	
26219	60 - 150 cm 1/4" + 5/8"	1

FESTA

CHYŁOMIERZ CYFROWY

- 0° - 360°
- dokładność ±0,1°
- rozdzielczość 0,1°
- funkcja automatycznego wyłączenia
- funkcja HOLD do przechowywania wartości mierzonych
- wyświetlacz z podświetleniem
- wymiary 60x60x25 mm
- bateria 1xAAA



· bag

· magnetyczna dolna strona

0.1°	0.1° LCD DISPLAY	1x AAA	0-50°C	82 g
-------------	----------------------------	---------------	---------------	-------------

N.p.	specyfikacja	
26218		1



FESTA

KĄTOMIERZ CYFROWY

200 mm	mm inch	LCD DISPLAY	0°-360°
0.05°	+/- 0.2°	MANUAL LOCKING	1x CR2032 3V



N.p.	specyfikacja	
26217	200 mm	1



FESTA

POZIOMNICA Z CYFROWYM WYŚWIETLACZEM

- wyświetlacz lcd
- skala 0° - 225°
- różnica 0,1°
- precyzja ± 0,3

ALU	0.1° LCD DISPLAY	3V LITHIUM
------------	----------------------------	-------------------



N.p.	specyfikacja	
26216	300 mm	1

FESTA

MULTIMETR

- Pomiar napięcia stałego: 200 mV - 300 V
- Pomiar napięcia przemiennego: 200 mV - 300 V
- Pomiar prądu stałego: 2000 µA - 10 A
- pomiar rezystancji: 200 Ω - 2 MΩ
- kontrola baterii: 1,5 V, 9 V
- wskaźnik niskiego poziomu baterii
- zabezpieczenie przed przeciążeniem

- IEC61010
- KAT III 300 V
- Certyfikat GS
- zasilanie: bateria 9 V (6F22)
- wymiary: 70×128×28 mm
- waga: 137 g (z baterią)
- akcesoria: kable testowe



N.p. specyfikacja
18429



1

FESTA

TESTER NAPIĘCIA

- Prąd zmienny/stały - 6 V, 12 V, 24 V, 50 V, 120 V, 230 V, 400 V
- wodoodporność IP54
- określenie polaryzacji
- KAT III 400 V



N.p. specyfikacja
18428



1

Laserliner®

LUXTEST-MASTER

Profesjonalne urządzenie do pomiaru natężenia światła

- Pomiar natężenia światła w miejscach pracy, biurach, budynkach użyteczności publicznej i przemysłu
- Czułe fotodiody z korekcją kosinusową do szerokoekranowego pomiaru światła
- Względne funkcje pomiarowe do referencyjnego pomiaru i porównywania
- Najlepsza funkcja do rejestrowania szybkiej zmiany poziomu oświetlenia.
- Funkcja automatycznego zapamiętywania wartości.
- Automatyczne i ręczne przełączanie zakresu
- Funkcja zerowania
- Pomiaru zmienne: Lux (lm | m 2), świece (lm | ft 2)
- Wyświetlacz Min | Max
- 1/4 " gwint do umieszczenia na statyw



N.p. specyfikacja

	Zakres pomiaru	20 Lux . . . 200000 Lux
26520	Zakres częstotliwości:	± 3% referencyjna żarówka w 2854 K
	Cosinus odchylenie kątowe:	± 2% (30°), ± 6% (60°)



1

specyfikacja

W dostawie z: bateria, pokrowiec

Laserliner®

AIRFLOWTEST-MASTER

Profesjonalny anemometr do pomiaru przepływu powietrza, przepływu objętościowego i prędkości wiatru

- Zintegrowany czujnik do pomiaru temperatury otoczenia, wilgotności względnej i punktu rosy
- Interfejs USB do przechowywania danych pomiarowych
- Oprogramowanie komputerowe - Duży wirnik: 65 mm.
- Min. | Maks. wyświetlacz
- 1/4 " gwint do połączenia na statywie z pomiarem długoterminowym
- Podświetlany, przezroczysty wyświetlacz z trwale widocznymi wartościami temperatury otoczenia i wilgotności względnej



N.p. specyfikacja

	Przepływ:	0.80...30 m s ± 2%
	Temperatura otoczenia:	-10...60 °C ± 1.5°C
26521	Wilgotność względna:	20%...80% ± 3%
	Przepływ powietrza:	0...99990 CMM



RECORDING ON A PC

specyfikacja

W dostawie z: PC software, USB kabel, bateria, walizka



1



FESTA

OŁÓWEK STOLARSKI HB



MOQ
12

N.p.	specyfikacja	
13270	HB · 180 mm	96
13271	HB · 180 mm · zestaw 3 szt	32
13265	HB · 250 mm	96



FESTA

OŁÓWEK STOLARSKI HB



MOQ
50

N.p.	specyfikacja	
13269	HB · 180 mm	50
13266	HB · 250 mm	50



FESTA

OŁÓWEK STOLARSKI HB



MOQ
12

N.p.	specyfikacja	
13272	HB · 250 mm	96
13264	HB · 250 mm · bez drukowania	96



FESTA

OŁÓWEK STOLARSKI HB



MOQ
50

N.p.	specyfikacja	
13268	250 mm	50



FESTA

OŁÓWEK TRÓJKĄTNY HB



MOQ
12

N.p.	specyfikacja	
13278	250 mm	96



FESTA

OŁÓWEK 6H

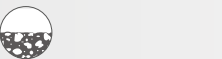

MOQ
12

N.p.	specyfikacja	
13275	6H · 250 mm	96



FESTA

OŁÓWEK



MOQ
12

N.p.	specyfikacja	
13273	175 mm czerwony grafit - szkło, ceramika	144



FESTA

OŁÓWEK

N.p.	specyfikacja	
13274	175 mm, czerwony niebieski	96



OLÓWEK STOLARSKI HB



MOQ
12

N.p.	specyfikacja	
13280	180 mm	96



OLÓWEK Z CZERWONYM GRAFITEM

MOQ
12

N.p.	specyfikacja	
13276	175 mm	144



papier ścierny

TEMPERÓWKA



N.p.	specyfikacja	
13261		12



FESTA

OLÓWEK STALOWY Z KLIPSEM HB

Zapassowe wkłady grafitowe 13263, 13267



N.p.	specyfikacja	
13288		20



FESTA

OLÓWEK STALOWY Z KLIPSEM HB

Zapassowe wkłady grafitowe 13263, 13267



N.p.	specyfikacja	
13262	150 mm	20



FESTA

OLÓWEK Z WYMIENNYM GRAFITEM HB



N.p.	specyfikacja	
13279	ołówek + 2x zapassowe grafity HB	24
13284	Zapassowe wkłady grafitowe 5 szt	20

FESTA

ZAPASOWE WKŁADY KOLOR

dla 13262, 13288



N.p.	specyfikacja	
13267	● 2x żółty ● 2x czerwony ● 2x niebieski	1

FESTA

ZAPASOWE WKŁADY GRAFITOWE HB

dla 13262, 13288



N.p.	specyfikacja	
13263	● 6x czarny	20





MARKER PERMANENTNY



N.p.	specyfikacja	
13200	biały	1
13201	czarny	1
13202	czerwony	1



NEW

MARKER PERMANENTNY



- mocna końcówka
- Do znakowania nawet na tłustych i mokrych powierzchniach



N.p.	specyfikacja	MOQ
13216	czerwony	12
13217	czarny	12
13218	niebieski	12
13219	zielony	12



MARKER PERMANENTNY



- 2 rodzaje końcówki markera
- Do znakowania nawet na tłustych i mokrych powierzchniach



N.p.	specyfikacja		
13227	biały	ALU	40
13222	biały	PVC	12
13228	czerwony	ALU	40
13229	czarny	ALU	40
13230	niebieski	ALU	12
13231	zielony	ALU	12



MARKER PERMANENTNY



N.p.	specyfikacja	
13214	biały	12
13225	czerwony	12
13226	czarny	12
13223	niebieski	12
13224	zielony	12



MARKER PERMANENTNY



N.p.	specyfikacja	
13235	czerwony	12
13236	czarny	12
13237	niebieski	12
13238	zielony	12



FESTA

MARKER,
PERMANENTNY



N.p.	Specyfikacja	
13246	● czarny	1
13247	● czerwony	1
13248	○ biały	1



MARKER PERMANENTNY,
PODWÓJNA KOŃCÓWKA



MOQ
12



N.p.	Specyfikacja	
13206	○ biały	12



MARKER PERMANENTNY,
PODWÓJNA KOŃCÓWKA



MOQ
12



N.p.	specyfikacja	
13212	● czarny	12



MARKER PERMANENTNY,
PODWÓJNA KOŃCÓWKA



MOQ
12



N.p.	Specyfikacja	
13207	● czerwony	12
13208	● niebieski	12



MARKER PERMANENTNY MINI



· 9 cm



MOQ
72



N.p.	specyfikacja	
13205	● ● ● ● ●	72



FESTA

KREDKI WOSKOWE
5 SZT
· Ø 13 x 110 mm

5x



N.p.	specyfikacja	
13240	5 kolor	20
13241	● czerwony	20
13242	● czarny	20

N.p.	specyfikacja	
13243	● żółty	20
13244	● zielony	20
13245	○ biały	20



MOBILNY UCHWYT NA SPREJ SOPPEC

· Do sprejów Trackmarker a Fluo



N.p.	specyfikacja	
13296		1



KREDKI WOSKOWE
6 SZT

6x



N.p.	specyfikacja	
13277	● ● ● ● ● ●	88



BIAŁA KREDA

12x



N.p.	specyfikacja	
13260	12 x 12 x 80 mm	46



UCHWYT PISTOLETOWY NA SPREJ SOPPEC

· Do sprejów Trackmarker a Fluo



N.p.	specyfikacja	
13295		1



SPRAY FLUORESCENCYJNY TRACKMARKER 500ML

- Wysoka widoczność dzięki pigmentowi fluorescencyjnemu
- Czapka bezpieczeństwa
- Szybkie suszenie 10 min.
- Trwałość 3 miesiące
- Użyj - Beton, Asfalt, Trawa, Żwir, Piasek, Kamień, Drewno



N.p.	specyfikacja	
13250	● żółty	12
13251	● czerwony	12
13252	● pomarańczowy	12
13253	● zielony	12
13254	● różowy	12
13249	● niebieski	12



SPRAY FLUORESCENCYJNY MARK 6M FLUO 500 ML

- Wysoka widoczność dzięki pigmentowi fluorescencyjnemu
- Czapka bezpieczeństwa
- Szybkie suszenie 10 min.
- Trwałość 6 miesiące
- Użyj - Beton, Asfalt, Trawa, Żwir, Piasek, Kamień, Drewno



N.p.	specyfikacja	
13360	● żółty	12
13361	● czerwony	12
13362	● pomarańczowy	12
13363	● zielony	12
13364	● różowy	12
13365	○ biały	12



SPRAY FLUORESCENCYJNY FLUO 500 ML

- Wysoka widoczność dzięki pigmentowi fluorescencyjnemu
- Czapka bezpieczeństwa
- Szybkie suszenie 10 min.
- Trwałość 12 miesiące
- Użyj - Beton, Asfalt, Trawa, Żwir, Piasek, Kamień, Drewno



N.p.	specyfikacja	
13350	● żółty	12
13351	● czerwony	12
13352	● pomarańczowy	12
13353	● zielony	12
13354	● różowy	12
13355	○ biały	12



SPRAY FLUORESCENCYJNY IDEAL 500 ML

- Wysoka widoczność dzięki pigmentowi fluorescencyjnemu
- Czapka bezpieczeństwa
- Szybkie suszenie 10 min.
- Trwałość 12 miesiące
- Użyj - Beton, Asfalt, Trawa, Żwir, Piasek, Kamień, Drewno



N.p.	specyfikacja	
13255	● żółty	12
13256	● czerwony	12
13257	● pomarańczowy	12
13258	● zielony	12
13259	● różowy	12



KDS®

Noże japońskiej firmy KDS

- znakomita ergonomia rękojeści
- duża wydajność i żywotność ostrza
- najwyższej klasy materiał ostrza
- niski opór cięcia, pozwalający na łatwe cięcie

KDS®
 NÓŻ, OSTRZE ŁAMANE

N.p.	specyfikacja		
16002	LC405 18 mm zielony	25	
16011	LB10 zapasowe ostrze	10	

KDS®
 NÓŻ, OSTRZE ŁAMANE

N.p.	specyfikacja		
16003	G11 18 mm + 2 ostrza	10	
16012	GB10 zapasowe ostrze	10	

KDS®
 NÓŻ, OSTRZE ŁAMANE

N.p.	specyfikacja		
16019	L19 18 mm + 2 ostrza	10	
16011	LB10 zapasowe ostrze	10	
16012	GB10 zapasowe ostrze	10	

KDS®
 NÓŻ, OSTRZE ŁAMANE

N.p.	specyfikacja		
16004	H11 25 mm	10	
16013	HB10 zapasowe ostrze	10	

KDS®
 NÓŻ, OSTRZE ŁAMANE

N.p.	specyfikacja		
16005	S14 9 mm + 2 ostrza	10	
16010	SB10 zapasowe ostrze	10	

KDS®
 SKALPEL

N.p.	specyfikacja		
16006	D12 + 16 ostrzei	10	

KDS®
 OSTRZA ZAPASOWE KDS

10x

N.p.	specyfikacja		
16010	SB10 9 0,38 mm	13 segmentów	20
16011	LB10 18 0,5 mm	15 segmentów	20
16012	GB10 18 0,6 mm	15 segmentów	20
16013	HB10 25 0,7 mm	7 segmentów	10

KDS®
 OSTRZA ZAPASOWE KDS

- specjalny stop
- podwójne ostrzenie
- zwiększona żywotność
- niski opór cięcia, pozwalający na łatwe cięcie



N.p.	specyfikacja		
16016	LB10B 18 0,5 mm	8 segmentów	20
16017	HB10B 25 0,7 mm	7 segmentów	10

KDS®
 STOJAK

N.p.	specyfikacja		
16999	stojak	1	
16998	stać z przedmiotami	1	



- przedmioty na stoisku 16998 : 16001 · 5 szt.
- 16003 · 5 szt.
- 16004 · 3 szt.
- 16005 · 3 szt.
- 16006 · 2 szt.
- 16008 · 3 szt.
- 16010 · 4 szt.
- 16012 · 4 szt.
- 16016 · 4 szt.
- 16018 · 4 szt.
- 16019 · 4 szt.
- 16020 · 4 szt.

• zdjęcie ilustracyjne



FESTA



system łamania ostrza



NÓŻ, OSTRZE ŁAMANE

· antypoślizgowe gumowanie



N.p.	specyfikacja	
16099	18 mm	12

FESTO



**NÓŻ, OSTRZE ŁAMANE
OSTRZE CERAMICZNE**

· 3x ostrzejszy niż stalowe ostrze
· 10 razy dłuższa żywotność
· ogniotrwały, nieprzewodzący, niemagnetyczny



N.p.	specyfikacja	
16131	18 mm	10
16066	zapasowe ostrza 18 mm, 5 szt.	10



NÓŻ, OSTRZE ŁAMANE



N.p.	specyfikacja	
16110	L11 18 mm + 1 ostrze	12



NÓŻ, OSTRZE ŁAMANE



N.p.	specyfikacja	
16100	L12 18 mm + 1 ostrze	12



NÓŻ, OSTRZE ŁAMANE



N.p.	specyfikacja	
16105	L17 18 mm + 1 ostrze	12



NÓŻ, OSTRZE ŁAMANE



N.p.	specyfikacja	
16125	L4 9 mm	24
16120	L8 18 mm	24



NÓŻ, OSTRZE ŁAMANE



N.p.	specyfikacja	
16115	L10 9 mm	24



FESTA
NÓŻ, OSTRZE ŁAMANE

ALU		
N.p.	specyfikacja	
16150	18 mm	24
16151	18 mm bez drukowania FESTA	20



FESTA
NÓŻ, OSTRZE ŁAMANE

ALU		
N.p.	specyfikacja	
16136	18 mm	12



FESTA
NÓŻ, OSTRZE ŁAMANE

ALU		
N.p.	specyfikacja	
16137	25 mm	12



FESTA
NÓŻ, OSTRZE ŁAMANE
· antypoślizgowe gumowanie

	ALU	
N.p.	specyfikacja	
16090	18 mm	12



FESTA
NÓŻ, OSTRZE ŁAMANE
· antypoślizgowe gumowanie

	ALU	
N.p.	specyfikacja	
16091	25 mm	6



FESTA
NÓŻ, OSTRZE ŁAMANE
· antypoślizgowe gumowanie

ALU		
N.p.	specyfikacja	
16145	L25 18 mm	12



FESTA
NÓŻ, OSTRZE ŁAMANE
· antypoślizgowe gumowanie

ALU		
N.p.	specyfikacja	
16144	L24 18 mm	12



NÓŻ, OSTRZE ŁAMANE

ALU		
N.p.	specyfikacja	
16143	18 mm	12



NÓŻ, OSTRZE ŁAMANE

ALU		
N.p.	specyfikacja	
16142	18 mm	12



NÓŻ, OSTRZE ŁAMANE

ALU		
N.p.	specyfikacja	
16025	18 mm	12



FESTA
NÓŻ, OSTRZE ŁAMANE

ALU		
N.p.	specyfikacja	
16029	18 mm	25



FESTA
NÓŻ, OSTRZE ŁAMANE
· antypoślizgowe gumowanie

ALU		
N.p.	specyfikacja	
16146	18 mm	12



FESTA

NÓŻ, OSTRZE ŁAMANE

· antypoślizgowe gumowanie



N.p.	specyfikacja	
16147	25 mm	12



FESTA

NÓŻ, OSTRZE ŁAMANE

· antypoślizgowe gumowanie



N.p.	specyfikacja	
16130	L18 18 mm + 5 ostrze	12



FESTA

NÓŻ, OSTRZE ŁAMANE

· antypoślizgowe gumowanie



N.p.	specyfikacja	
16135	L20 25 mm + 5 ostrze	6



FESTA

NÓŻ, OSTRZE ŁAMANE

· antypoślizgowe gumowanie



N.p.	specyfikacja	
16140	L22 18 mm	12



FESTA

NÓŻ, OSTRZE ŁAMANE

· antypoślizgowe gumowanie



N.p.	specyfikacja	
16034	25 mm	12



FESTA

NÓŻ, OSTRZE ŁAMANE



N.p.	specyfikacja	
16085	9 mm	24



FESTA

NÓŻ, OSTRZE ŁAMANE



N.p.	specyfikacja	
16086	18 mm	24



NÓŻ BEZPIECZNY

N.p.	specyfikacja	
16044		20



NÓŻ BEZPIECZNY

· ostrze samoczynnie chowające się

N.p.	specyfikacja	
16057	135 mm	12



FESTA

NÓŻ BEZPIECZNY



N.p.	specyfikacja	
16058		6
16074	zapasowe ostrza 10 szt.	1

16074



NEW



FESTO

NÓŻ SKŁADANY

+2 SK4



N.p.	specyfikacja	
16039		6
16087	Zapassowe ostrza	1



FESTO

NÓŻ TURBO

+5 ALU



N.p.	specyfikacja	
16037	+ 5 ostrze	6

FESTO

NÓŻ SKŁADANY

+5 ALU



N.p.	specyfikacja	
16023	+ 5 ostrze	12
16071	Zapassowe ostrza 10 szt.	10

FESTO

ZESTAW NOŻY

ALU

N.p.	specyfikacja	
16095	25 ostrze	1



ZESTAW SKALPELI

22x



N.p.	specyfikacja	
16282		24



ZESTAW SKALPELI

13x



N.p.	specyfikacja	
16281		10



FESTO

NÓŻ

antyposlizgowe gumowanie

ALU +2



N.p.	specyfikacja	
16035	+ 2 ostrze	12



FESTO

NÓŻ

ALU +3



N.p.	specyfikacja	
16033	NP 110 + 3 ostrze	5





NÓŻ

ALU



N.p.	specyfikacja	
16032	NP 109	48



NÓŻ

ALU



N.p.	specyfikacja	
16031	NS 107 B	24



NÓŻ

ALU



N.p.	specyfikacja	
16030	NS 107	24



NÓŻ, OSTRZE ŁAMANE

ALU



N.p.	specyfikacja	
16046	18 mm	12



NÓŻ, OSTRZE ŁAMANE

ALU



N.p.	specyfikacja	
16028	S 201 18 mm	24



NÓŻ, OSTRZE ŁAMANE

ALU



N.p.	specyfikacja	
16026	P 205 18 mm	30



NÓŻ, OSTRZE ŁAMANE

HOBBY



N.p.	specyfikacja	
16021	P 201 9 mm	60



NÓŻ, OSTRZE ŁAMANE

HOBBY



N.p.	specyfikacja	
16024	P 204 18 mm	60



NÓŻ, OSTRZE ŁAMANE

HOBBY



N.p.	specyfikacja	
16141	18 mm	24

antyposlizgowe gumowanie

MOQ 24



ZESTAW NOŻY

HOBBY 12x

N.p.	specyfikacja	
16053	9 mm	12
16055	18 mm	12



ZESTAW NOŻY

HOBBY 3x

N.p.	specyfikacja	
16043		24





NÓŻ DO WYKŁADZIN

· na dywan i podłogę

N.p.	specyfikacja	
16036	45 mm	12



NÓŻ HAKOWY Z CHOWANYM OSTRZEM

· na dywan i podłogę

N.p.	specyfikacja	
16041		12



50 mm

SKROBAK DO SZYB

ALU		
N.p.	specyfikacja	
16059	50 mm	10
16082	zapasowe ostrza	1



100 mm

SKROBAK DO SZYB

· do stosowania z ostrzami 18 mm do noży łamanych

ALU		
N.p.	specyfikacja	
16054	100 mm	1



100 mm

SKROBAK DO SZYB

N.p.	specyfikacja	
16052	48 cm	6
16070	zapasowe ostrza	25



38 mm

FESTA SKROBAK DO SZYB

· antypoślizgowe gumowanie

N.p.	specyfikacja	
16049		12
16069	zapasowe ostrza	1



60 mm

SKROBAK DO SZYB

N.p.	specyfikacja	
16051		24



55 mm

SKROBAK DO SZYB

N.p.	specyfikacja	
16050		24



ZESTAW SKROBAKÓW DO APLIKACJI I USUWANIA SILIKONU

3x		
N.p.	specyfikacja	
16042		12

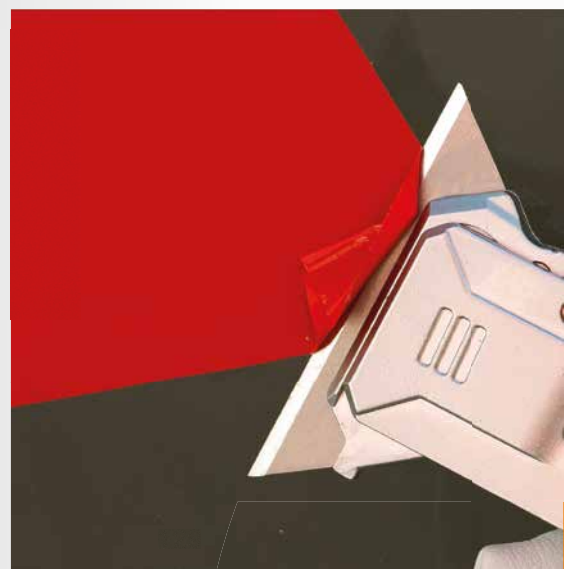



FESTA

OSTRZA ZAPASOWE

- 7 segmentów
- 3 razy dłuższa żywotność
- podwójne ostrzenie
- niski opór skrawania



N.p.	specyfikacja	
16064	25 0,7 mm	20

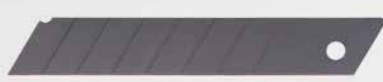

FESTA

OSTRZA ZAPASOWE

- 8 segmentów
- 3 razy dłuższa żywotność
- podwójne ostrzenie
- niski opór skrawania



N.p.	specyfikacja	
16062	18 0,7 mm	10



FESTA

OSTRZA ZAPASOWE

- 15 segmentów
- 3 razy dłuższa żywotność
- podwójne ostrzenie
- niski opór skrawania

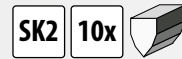

N.p.	specyfikacja	
16063	18 0,7 mm	10



FESTA

ZAPASOWE OSTRZA CERAMICZNE

- 8 segmentów
- 3x ostrzejszy niż stalowe ostrze
- 10 razy dłuższa żywotność
- ogniotwały, nieprzewodzący, niemagnetyczny



N.p.	specyfikacja	
16066	18 0,6 mm	10



OSTRZA ZAPASOWE

- 8 segmentów
- podwójne ostrzenie



N.p.	specyfikacja	
16078	18 0,5 mm	25



OSTRZA ZAPASOWE

- 8 segmentów
- podwójne ostrzenie



N.p.	specyfikacja	
16077	18 0,6 mm	25



OSTRZA ZAPASOWE

- 7 segmentów



N.p.	specyfikacja	
16068	25 0,6 mm	20



OSTRZA ZAPASOWE

- 8 segmentów



N.p.	specyfikacja	
16065	18 0,5 mm	60



OSTRZA ZAPASOWE

- 15 segmentów



N.p.	specyfikacja	
16081	18 0,5 mm	60



OSTRZA ZAPASOWE

- 4 segmentów



N.p.	specyfikacja	
16067	18 0,5 mm	10



OSTRZA ZAPASOWE 30°

- 7 segmentów



N.p.	specyfikacja	
16061	9 0,4 mm	60

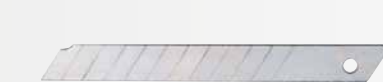

OSTRZA ZAPASOWE

- 13 segmentów



N.p.	specyfikacja	
16060	9 0,45 mm	10



FESTA

OSTRZA ZAPASOWE



N.p.	specyfikacja	
16072	R 004	10



FESTA

OSTRZA ZAPASOWE



N.p.	specyfikacja	
16075	R 003	10



OSTRZA ZAPASOWE



N.p.	specyfikacja	
16071	R 001	60



OSTRZA ZAPASOWE

5x

N.p.	specyfikacja	
16083	18 mm	50



OSTRZA ZAPASOWE

10x

N.p.	specyfikacja	
16073	R 002	60



OSTRZA ZAPASOWE

5x

N.p.	specyfikacja	
16084	18 mm	50

FESTA

OSTRZA ZAPASOWE

dla 16058

10x

N.p.	specyfikacja	
16074		1

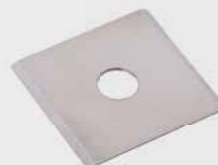

OSTRZA ZAPASOWE

dla 34315

N.p.	specyfikacja	
34316		1



OSTRZA ZAPASOWE

dla 16052

N.p.	specyfikacja	
16070	100 mm	25



FESTA

NÓŻ DO WEŁNY MINERALNEJ

N.p.	specyfikacja	
16198	44,5 33 cm	12



FESTA

NÓŻ NA IZOLACE

do wełny mineralnej, polistyrenu

N.p.	specyfikacja	
16199	48 35 cm	10



FESTA

MACZETA

N.p.	specyfikacja	
45069	490 mm	6



FESTA

MACZETA

N.p.	specyfikacja	
44950	490 mm	4



MACZETA

N.p.	specyfikacja	
45083	430 mm	12
45084	600 mm	6



MACZETA

uchwyt wykonany z drewna jesionowego

N.p.	specyfikacja	
45081	510 mm	36
45082	710 mm	36



FESTA

NÓŻ MYŚLIWSKI

- uchwyt nylonowy
- ostrze pokryte teflonem
- pochwa z bezpiecznikiem i klipem



INOX	TEFLON	NYLON	N.p.	specyfikacja	
			16234	21 10 cm	10



FESTA

NÓŻ MYŚLIWSKI



INOX	TEFLON	N.p.	specyfikacja	
		16229	23 10 cm	12



FESTA

DŁUTO WIELOFUNKCYJNE

- pogrubione ostrze



MOQ
12

INOX	N.p.	specyfikacja	
	16231	20 8 cm	12



NÓŻ TECHNICZNY

- pogrubione ostrze

INOX	N.p.	specyfikacja	
	16230	21 10 cm	12



FESTA

NÓŻ DO DYWANÓW I PODŁÓG

N.p.	specyfikacja	
16225	20 8,5 cm	12



FESTA

NÓŻ DLA ELEKTRYKÓW

- pogrubione ostrze

INOX	N.p.	specyfikacja	
	16212	15 3,2 cm	12



FESTA

NÓŻ DO ZDEJMOWANIA IZOLACJI

N.p.	specyfikacja	
16201	Ø 8 - 27 mm	10



FESTA

NÓŻ DLA ELEKTRYKÓW

INOX	N.p.	specyfikacja	
	16211	20 8,5 cm	10



FESTA

NÓŻ DLA ELEKTRYKÓW

INOX	N.p.	specyfikacja	
	16210	20,5 9 cm	10



FESTA

NÓŻ SKŁADANY



INOX	N.p.	specyfikacja	24
	16219	19 11 cm	



FESTA

NÓŻ SKŁADANY



INOX	N.p.	specyfikacja	24
	16218	18,5 10,5 cm	



FESTA

NÓŻ SKŁADANY



INOX	N.p.	specyfikacja	24
	16220	18,5 11 cm	



FESTA

NÓŻ SKŁADANY



INOX	N.p.	specyfikacja	24
	16235	17,5 8,5 cm	



FESTA

NÓŻ SKŁADANY



INOX	N.p.	specyfikacja	24
	16221	21 12 cm	



FESTA

NÓŻ SKŁADANY



INOX	N.p.	specyfikacja	24
	16236	22,5 10 cm	



FESTA

NÓŻ SKŁADANY



INOX	N.p.	specyfikacja	1
	16209	14,5 5,5 cm	



FESTA

NÓŻ SKŁADANY



INOX	N.p.	specyfikacja	24
	16222	20 12 cm	



FESTA

NÓŻ SKŁADANY



INOX	ALU	N.p.	specyfikacja	24
		16223	18,5 10,5 cm	

**FESTA****NÓŻ WIELOFUNKCYJNY**

· 5 funkcji

INOXN.p. specyfikacja
16228 27 | 10,5 cm

24

**FESTA****NÓŻ WIELOFUNKCYJNY**

· 10 funkcji

INOXN.p. specyfikacja
16226 17,5 | 7 cm

24

**NÓŻ WIELOFUNKCYJNY**

· 7 funkcji

INOXN.p. specyfikacja
16224 17,5 | 7 cm

24

**NÓŻ WIELOFUNKCYJNY**

· 3 funkcji

INOXN.p. specyfikacja
16227 20,5 | 10 cm

24

**FESTA****SZCZYPCE WIELOFUNKCYJNE**· 9 funkcji
· futerał**CrV**N.p. specyfikacja
16232

12

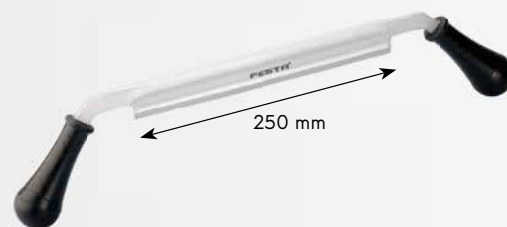
NEW**FESTA****OŚNIK PROSTY****CrV**N.p. specyfikacja
24132 250/490 mm

1

**STRUG DREWNIANY**N.p. specyfikacja
19510 220 x 65 x 130 mm, ostrze 48 mm 1**STRUG DREWNIANY**N.p. specyfikacja
19515 200 x 55 x 130 mm, ostrze 39 mm 1**STRUG DREWNIANY**N.p. specyfikacja
19520 225 x 27 x 155 mm, ostrze 27 mm 1



FESTA

DŁUTO

CrV

N.p.	specyfikacja	
19490	6 mm 290 mm	6
19491	8 mm 290 mm	6
19492	10 mm 290 mm	6
19493	12 mm 290 mm	6
19494	14 mm 290 mm	6
19495	16 mm 290 mm	6

N.p.	specyfikacja	
19496	18 mm 290 mm	6
19497	20 mm 290 mm	6
19498	22 mm 290 mm	6
19499	25 mm 290 mm	6
19501	32 mm 290 mm	6
19502	38 mm 290 mm	6



FESTA

DŁUTO WIELOFUNKCYJNE

INOX

N.p.	specyfikacja	
16231	20 80 mm	12



MOQ 12



FESTA

ZESTAW DŁUT

CrV

5x

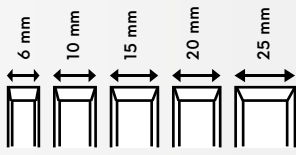

N.p.	specyfikacja	
19451		10



FESTA

ZESTAW DŁUT

CrV

4x

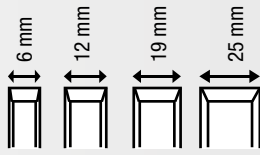

N.p.	specyfikacja	
19457		10



ZESTAW DŁUT

4x

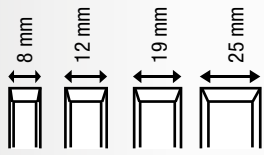

N.p.	specyfikacja	
19455		30

FESTA



FESTA

ZESTAW DŁUT

CrV

8x

N.p.	specyfikacja	
19458	365 125mm	1



ZESTAW DŁUT

4x

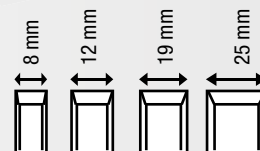

N.p.	specyfikacja	
19450		20



ZESTAW DŁUT

12x

CrV

N.p.	specyfikacja	
19459		5

FESTA

OSTRZAŁKA DO NOŻY I NOŻYCZEK 16 W 1



	30° Anvil	
	45° Anvil	
	50° Anvil	
	23° Bypass	
	35° Bypass	
	65° Bypass	
	Deburr Tool	



N.p. specyfikacja

45073



1



ZAOKRĄGLONA OSEŁKA

N.p. specyfikacja 20

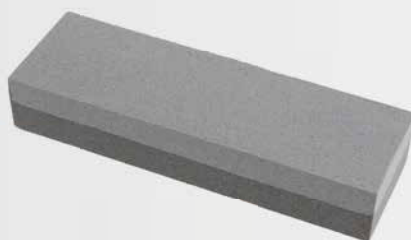

OSEŁKA

N.p. specyfikacja 1



OSEŁKA DO KOSY

N.p. specyfikacja 100



OSTRZAŁKA DO NOŻY I NOŻYCZEK

N.p. specyfikacja 20



OSTRZAŁKA DO NOŻY I NOŻYCZEK

N.p. specyfikacja 1



OSTRZAŁKA DO NOŻY I NOŻYCZEK

N.p. specyfikacja 20



OSTRZAŁKA DO NOŻY I NOŻYCZEK 6 V 1

N.p. specyfikacja 10





FESTA
POWER X TOOLS

SPAWARKA DO RUR

Napięcie / częstotliwość 230 V / 50 Hz
 Pobór energii 750 / 1500 W
 Temperatura 0-300 C°
 Rozszerzenia Ø 20,25,32,40,50,63 mm
 Waga 1,6 kg



· sprzęt: miernik, poziomica, śrubokręt, klucz inbusowy, nożyce do rur, 4 x adapter spawalniczy



N.p.
17182

1



FESTA
POWER X TOOLS

SPAWARKA DO RUR

Napięcie / częstotliwość 230 V / 50 Hz
 Pobór energii 800 / 1000 W
 Temperatura 0-300 C°
 Rozszerzenia Ø 16, 20, 25, 32 mm
 Waga 1 kg



· sprzęt: klucz inbusowy, 4 x adapter spawalniczy



N.p.
17183

1

FESTA

OBCINAK DO RUR PVC

Ø max.
42 mm



N.p.	specyfikacja	
17027		10
16315	zapasowe ostrza	1



OSTRZA ZAPASOWE

dla 17027

N.p.	specyfikacja	
16315		1



FESTA



FESTA

OBCINAK DO RUR PVC

Ø max.
32 mm



N.p.	specyfikacja	
17037		12



OBCINAK DO RUR PVC

Ø max.
42 mm



N.p.	specyfikacja	
17026		6



NEW

FESTA

OBCINAK DO RUR

INOX ALU

ALU Cu PVC



N.p.	specyfikacja	
16305	Ø 22 mm	10
16306	Ø 15 mm	10
16307 NEW	Ø 28 mm	10



NEW

FESTA

OBCINAK DO PCV RUR

PLASTIC INOX

PVC

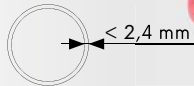

N.p.	specyfikacja	
16308	Ø 20 - 50 mm	10

FESTA

OBCINAK DO RUR

Ø 15 mm
Ø 22 mm
Ø 28 mm

3x INOX ALU

ALU Cu PVC



N.p.	specyfikacja	
16309		1



FESTA

OBCINAK DO RUR
CENKOŚCIENNYCH



3-22
mm



N.p.	specyfikacja	
16301		10
16311	zapasowe ostrze koła	1

FESTA

OBCINAK DO RUR
CENKOŚCIENNYCH



6-64
mm



N.p.	specyfikacja	
16304		6
16312	zapasowe ostrze koła	1

OBCINAK
DO RUR CENKOŚCIENNYCH



3-32
mm



N.p.	specyfikacja	
16303		10
16311	zapasowe ostrze koła	1

OBCINAK
DO RUR CENKOŚCIENNYCH



3-32
mm



N.p.	specyfikacja	
16300		10
16310	zapasowe ostrze koła	1

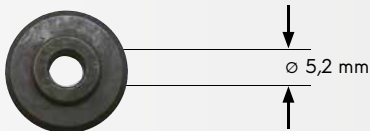

KÓŁKO ZAPASOWE



N.p.	specyfikacja	
16310	Ø 17,5 mm x 6 mm za 16300	1
16311	Ø 18,0 mm x 4,5 mm za 16303, 16301	1
16312	Ø 27,5 mm x 6 mm za 16304	1



FESTA

SZCZYPCE DO LISTEW
PCV Z OSTRZAMI

· listwy, rurki, profile

5x Ø 17 mm Ø 20 mm Ø 27 mm

N.p.	specyfikacja	
17050	60 250 mm	



NEW

FESTA

GRADOWNIK
DO RUR



6-38
mm ALU



N.p.	specyfikacja	
16319	Ø 6 - 38 mm	1

FESTA

GRADOWNIK



1/4"

N.p.	specyfikacja	
16321		1

GRADOWNIK
DO RUR



6-32
mm



N.p.	specyfikacja	
16320		1

FESTA

GRADOWNIK



HSS Ø 25 mm 90°



N.p.	specyfikacja	
20360		10

GRADOWNIK



N.p.	specyfikacja	
20361		1



WKRĘTAK PŁASKI

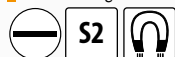

N.p.	specyfikacja	
18113	3 x 75 mm	12
18114	4 x 100 mm	12
18115	5,5 x 125 mm	12
18116	6,5 x 150 mm	12
18118	8 x 175 mm	6
18120	10 x 200 mm	6



WKRĘTAK PHILIPS

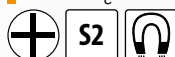

N.p.	specyfikacja	
18210	0 x 75 mm	12
18211	1 x 75 mm	12
18212	2 x 100 mm	12



WKRĘTAK POZIDRIVE

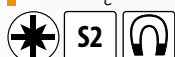

N.p.	specyfikacja	
18310	0 x 75 mm	12
18311	1 x 100 mm	12
18312	2 x 100 mm	12
18313	3 x 150 mm	6



WKRĘTAK TORX

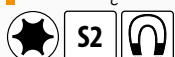

N.p.	specyfikacja	
18350	T6	12
18351	T7	12
18352	T8	12
18353	T9	12
18354	T10	12
18355	T15	12
18356	T20	12
18357	T25	12
18358	T27	12
18359	T30	12
18360	T40	6



WKRĘTAK PŁASKI KRÓTKI

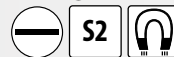

N.p.	specyfikacja	
18124	5,5 x 38 mm	12
18125	6,5 x 38 mm	12



WKRĘTAK PHILIPS KRÓTKI

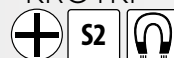

N.p.	specyfikacja	
18215	1 x 38 mm	12
18216	2 x 38 mm	12



WKRĘTAK POZIDRIVE KRÓTKI

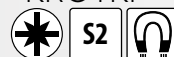

N.p.	specyfikacja	
18321	1 x 38 mm	12
18322	2 x 38 mm	12



WKRĘTAK + 7 KOŃCÓWEK BIT



- ⊖ S 5 · 6 mm
- ⊕ PH 1 · 2 · 3
- ⊗ T 15 · 20

N.p.	specyfikacja	
18425		10

NEW



ZESTAW WKRĘTAKÓW I BITÓW

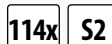

N.p.	specyfikacja	
18434		1

- wkrętak nasadowy
- wkrętak nasadowy precyzyjny
- wkrętaki
 - ⊖ 3x75, 5x75, 5x100, 6x100, 6x150, 8x150
 - ⊕ 0x75, 1x75, 1x100, 2x100, 2x150
 - ⊗ T10x75, T15x75
 - ⊖ VDE 2.5x75mm, 4.0x100mm
 - ⊖ próbnik napięcia
 - ⊖ 2.5x40, 3.0x40mm
 - ⊕ 00x40mm, 0x40mm,
 - ⊗ T6x40mm, T7x40mm
- inbus
 - 1/16", 5/64", 3/32", 1/8", 5/32", 3/16", 7/32", 1/4"
 - 1.5, 2.0, 2.5, 3.0, 4.0, 5.0, 5.5, 6.0mm
- nasadki
- końcówki
 - ⊖ 6mm, 7mm, 8mm, 9mm, 10mm, 11mm
 - ⊖ SL 3mm, 4mm, 4.5mm, 5mm, 5.5mm, 6mm, 7mm, 8mm
 - ⊕ PH0, PH0, PH1, PH1, PH2, PH2, PH3, PH3
 - ⊗ PZ0, PZ0, PZ1, PZ1, PZ2, PZ2, PZ3, PZ3,
 - ⊗ T6, T8, T10, T15, T20, T25, T27, T30, T35, T40
 - H1.5, H2.5, H3.0, H3.5, H4.0, H4.5, H5.0, H5.5, H6, H8
 - ⊖ S0, S1, S2, S3
 - ⊖ SL 1.5mm, 2.0mm, 2.5mm, 3.0mm, 4.0mm
 - ⊕ PH000, PH00, PH0, PH1
 - ⊗ T4, T5, T6, T7, T8, T9, T10, T15, T20
 - H0.7, H0.9
- końcówki precyzyjne



ZESTAW WKRETAKÓW

⊖ S 3x75 · 5x100 · 6,5x150mm

⊕ PH 0 · 1 · 2 · 3



7x



N.p. specyfikacja

18402

6



ZESTAW WKRETAKÓW

⊖ S 3x75 · 5x100 · 6x150mm

⊕ PH 0 · 1 · 2



6x



N.p. specyfikacja

18403

6



ZESTAW WKRETAKÓW

⊖ S 6,5x38 · 5,5x75 · 6,5x100 · 8x150 mm
2,5x50 · 3x50 mm

⊕ PH 2x38 · 1x75 · 2x100 · 3x150 mm
0x50 · 00x50 mm

⊛ T 5x50 · 6x50 · 7x50 · 8x50 · 9x50 · 10x50 mm



18x



N.p. specyfikacja

18424

6



ZESTAW WKRETAKÓW

⊖ S 3x75 · 5x100 · 6,5x150 mm

⊛ PZ 0 · 1 · 2



6x



N.p. specyfikacja

18404

6



ZESTAW WKRETAKÓW TORX

⊛ T 10 · 15 · 20 · 25 · 30



5x



N.p. specyfikacja

18340

6



ZESTAW WKRETAKÓW I KOŃCÓWEK BIT

⊖ S 3 x 75 · 4x100 · 5,5x125 · 6,5 x 150mm

⊕ PH1 x 100 · 2 x 100mm

⊖ adapter 1/4"

bity:

⊖ S 4 · 5 · 6 · 7

⊕ PH1 · 2 · 3

⊛ PZ1 · 2 · 3

⊛ T 10 · 15 · 20 · 25 · 30

⊖ H 2 · 3 · 4 · 5 · 6



27x



N.p. specyfikacja

18422

27 szt.

6



FESTA
INDUSTRY

WKRĘTAK ELEKTRO VDE PŁASKI



N.p.	specyfikacja		
18088	3 x 75 mm	S2	12
18089	4 x 100 mm	CrV	12
18090	5,5 x 125 mm	CrV	12
18091	6,5 x 150 mm	CrV	12
18092	8 x 175 mm	CrV	12



FESTA
INDUSTRY

WKRĘTAK ELEKTRO VDE PHILIPS



N.p.	specyfikacja		
18080	PH 0 x 60 mm	S2	12
18081	PH 1 x 80 mm	CrV	12
18082	PH 2 x 100 mm	CrV	12
18083	PH 3 x 150 mm	CrV	12



FESTA
INDUSTRY

ZESTAW WKRĘTAKÓW ELEKTR.

⊖ S 4x100 · 5,5x125 mm · próbnik napięcia 0 - 250 V

⊕ PH 0x60 · 1x80 · 2x100 mm



N.p.	specyfikacja	
18413		6

FESTA
INDUSTRY

WKRĘTAK ELEKTRO VDE POZIDRIVE



N.p.	specyfikacja		
18084	PZ 0 x 60 mm	S2	12
18085	PZ 1 x 80 mm	CrV	12
18086	PZ 2 x 100 mm	CrV	12
18087	PZ 3 x 150 mm	CrV	12



FESTA

WKRĘTAK UDAROWY PŁASKI



N.p.	specyfikacja		
18062	5,5 x 100 mm		12
18063	7 x 125 mm		6
18064	8 x 150 mm		8
18065	10 x 175 mm		6
18066	10 x 200 mm		6
18067	10 x 250 mm		6



FESTA

ZESTAW WKRĘTAKÓW ELEKTR.

⊖ S 4x100 · 5,5x125 · 6,5x150 mm ·

próbnik napięcia 0 - 250 V

⊕ PH 0x75 · 1x100 · 2x100 mm



N.p.	specyfikacja	
18410		40

FESTA

WKRĘTAK UDAROWY PHILIPS



N.p.	specyfikacja		
18070	PH 1 x 80 mm		8
18071	PH 2 x 100 mm		12
18072	PH 3 x 150 mm		6



FESTA

FESTA

WKRĘTAK UDAROWY POZIDRIVE



N.p.	specyfikacja		
18075	PZ 1 x 80 mm		12
18076	PZ 2 x 100 mm		12
18077	PZ 3 x 150 mm		6



FESTA

WKRĘTAK UDAROWY

⊖ S 7 x 35 · 8 x 35 · 8 x 70 mm

⊕ PH 2 x 35 · 3 x 35 · 3 x 70 mm

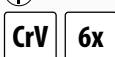

N.p.	specyfikacja	
18411		1



FESTA

ZESTAW WKRĘTAKÓW UDAROWYCH

⊖ S 5 · 6 · 8 mm

⊕ PH 1 · 2 · 3



N.p.	specyfikacja	
18423		10





FESTA

ZESTAW WKREŃTAKÓW I BITÓW

⊖ S 3x75 · 4x75 · 6x100 · 8x150 mm

⊕ PH 1x75 · 2x100 mm

⊙ adapter 1/4"

bit: ⊖ S 4 · 5 · 6 · 7 mm

⊕ PH 1 · 2 · 3

⊗ PZ 1 · 2 · 3

⊛ T 10 · 15 · 20

⊙ ↔ ⊠ adapter



N.p.	specyfikacja
18418	



10



FESTA

ZESTAW WKREŃTAKÓW

⊖ S 3x60 · 4x75 · 6x100 · 6x125 mm

⊕ PH 0x60 · 1x75 · 2x100 mm



N.p.	specyfikacja
18400	



10



FESTA

ZESTAW WKREŃTAKÓW

⊖ S 3x60 · 6x100 · 6x125 mm

⊕ PH 1x75 · 2x100 mm



N.p.	specyfikacja
18401	



1

FESTA

WKREŃTAK PŁASKI



N.p.	specyfikacja	
18101	3 x 75 mm	10
18102	4 x 100 mm	10
18103	5,5 x 100 mm	10
18104	5,5 x 125 mm	10
18105	6,5 x 100 mm	10
18106	6,5 x 125 mm	10
18107	8 x 160 mm	10
18108	10 x 160 mm	10

FESTA

WKREŃTAK PHILIPS



N.p.	specyfikacja	
18201	0 x 75 mm	10
18202	1 x 75 mm	10
18203	2 x 100 mm	10
18204	3 x 150 mm	10

FESTA

WKREŃTAK POZIDRIVE



N.p.	specyfikacja	
18301	0 x 75 mm	10
18302	1 x 75 mm	10
18303	2 x 100 mm	10
18304	3 x 150 mm	10

FESTA

WKREŃTAK NASADOWY



N.p.	specyfikacja	
18110		12



FESTA

WKREŃTAK NASADOWY

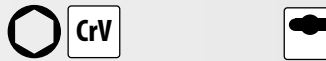

N.p.	specyfikacja	
18455	6 mm	12
18456	7 mm	12
18460	13 mm	12



FESTA

WKREŃTAK ELASTYCZNY

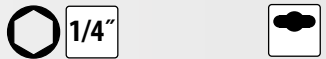

N.p.	specyfikacja	
18451		12



FESTA

WKREŃTAK ELASTYCZNY

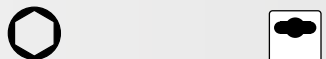

N.p.	specyfikacja	
18450	7 mm	6





ŚRUBOKRĘT Z GRZECHOTKĄ

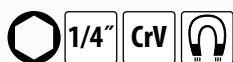

N.p. specyfikacja
18433

6



WKREŃTAK Z UCHWUTEM DO BITÓW

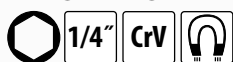

N.p. specyfikacja
18608

6



WKREŃTAK T + 20 KOŃCÓWEK BIT

- ⊖ S 3 · 4 · 5 · 6 · 8 mm
- ⊕ PH 0 · 1 · 2 · 3
- adapter + 5 · 6 · 7 · 8 · 9 · 10 · 11 · 12 · 13 mm



N.p. specyfikacja
18420

5



WKREŃTAKI PRECYZYJNE Z ADAPTEREM

- ⊖ S 1.5 · 2 · 2.5 · 3 · 3.5 mm
- ⊕ PH 000 · 00 · 0 · 1
- ⊗ PZ 0 · 1
- ⊛ T 5 · 6 · 7 · 8 · 9 · 10 · 15 · 20
- ⊙ H 0.9 · 1.3 · 2.0 · 2.5 · 3.0 · 4.0



N.p. specyfikacja
18431



6



WKREŃTAK Z BITAMI

- 1/4" ⊖ ↔ ⊙ 1/4"
- ⊖ S 3 · 4 · 5 · 6 · 7 · 5 L
- ⊕ PH 1 · 2 · 3 · 1L · 2L
- ⊗ PZ 1 · 2 · 3 · 1L · 2L
- ⊙ H 2 · 2.5 · 3 · 4 · 5 · 6
- ⊛ T 10 · 15 · 20 · 25 · 27 · 30
- ⊙ SQ 0 · 1 · 2 · 3
- 1/4" 5 · 6 · 7 · 8 · 9 · 10 · 11 · 12 · 13 mm



N.p. specyfikacja
18419



6



WKREŃTAKI PRECYZYJNE

- ⊖ S 1,5x50 · 2x50 · 2,5x50 mm
- ⊕ PH 000x50 · 00x50 · 0x50 mm



N.p. specyfikacja
18416

6



WKREŃTAKI PRECYZYJNE TORX

- ⊛ T 4 · 5 · 6 · 7 · 8 · 9 · 10x50 mm



N.p. specyfikacja
18417



6



WKREŃTAKI PRECYZYJNE ELEKTRO

- ⊖ S 2,4 · 3,0 mm
- ⊕ PH 0 · 1
- ⊛ T 6 · 8

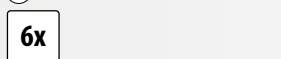

N.p. specyfikacja
18415



10

FESTA



NEW



FESTA

PRÓBNIK NAPIĘCIA

· AC - 110 V, 250 V



N.p. specyfikacja

18427

24

PRÓBNIK NAPIĘCIA

DIN VDE 0680
73/23 EEC



N.p. specyfikacja

18426 0 - 250 V

1



WKRETKI PRECYZYJNE

⊖ S 1,4 · 2,0 · 2,4 · 3,0 mm

⊕ PH 0 · 1



6x HOBBY



N.p. specyfikacja

18408

10

FESTA

OTWIERACZ DO BUTELEK

N.p. specyfikacja

18437



5



**KĄT ADAPTER
DÓ BITÓW 90°**



N.p.

18910



25



GRZECHOTKA DO BITÓW

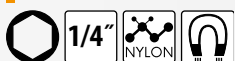

N.p. specyfikacja

18435 93 mm



1



WKRETKI PRECYZYJNE

⊖ S 1,0 · 1,2 · 1,4 · 1,8 · 2,4 · 3,0 mm

⊕ PH 00 · 0 · 1



11x HOBBY



N.p. specyfikacja

18409

48





BIT SKRĘTNY PH - 50 MM

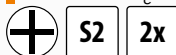

N.p.	specyfikacja	
18715	PH1 x 50 mm	1
18716	PH2 x 50 mm	1
18717	PH3 x 50 mm	1



BIT SKRĘTNY PZ - 50 MM



N.p.	specyfikacja	
18710	PZ1 x 50 mm	1
18711	PZ2 x 50 mm	1
18712	PZ3 x 50 mm	1



BIT SKRĘTNY T - 50 MM

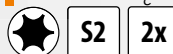

N.p.	specyfikacja	
18720	T10 x 50 mm	1
18721	T15 x 50 mm	1
18722	T20 x 50 mm	1
18723	T25 x 50 mm	1
18724	T30 x 50 mm	1
18725	T40 x 50 mm	1



BIT SKRĘTNY

- PH 2 · 2
- PZ 2
- T 15 · 15 · 20 · 20 · 25 · 30 · 40

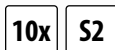

N.p.	specyfikacja	
18432		1



bity – profesjonalne końcówki z najwyższej jakości materiału S2

Technologia produkcji

Krzyżowe i płaskie końcówki wyprodukowane są z użyciem specjalnej technologii precyzyjnego kucia. Umożliwia to osiągnięcie wysokiej precyzji kształtu przy jednoczesnym podwyższeniu wytrzymałości o 20 % w stosunku do końcówek obrabianych. Po kuciu końcówki są hartowane dla uzyskania maksimum twardości i ciągliwości. Aby uzyskać ochronę antykorozyjną końcówki są następnie piaskowane.

TiN warstwa

naniesiona podwójnie na powierzchnię grotu podwyższa do maksimum twardość powierzchni, odporność na starcie oraz właściwości trące, dzięki którym grot nie ślizga się. Warstwa TiN jest równocześnie odporna na korozję.

Ziarna diamentu

dosłownie „wgrzyzą” się w główkę śruby lub wkrętu i utrzymają bit w jednej pozycji, pozwalając na osiągnięcie maksymalnego momentu dokręcania. Są gwarancją utrzymania końcówki w jednej pozycji. Końcówki najczęściej zostają uszkodzone w wyniku wyslizgnięcia się.

Rowki antypoślizgowe

na powierzchni kątów grotów stanowią kolejny, bardzo efektywny, element antypoślizgowy.

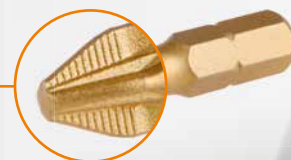



BIT PH

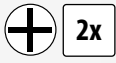

N.p.	specyfikacja	
18632A	PH2 x 25 mm	1
18633A	PH3 x 25 mm	1



BIT PZ

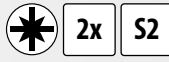

N.p.	specyfikacja	
18636A	PZ1 x 25 mm	1
18637A	PZ2 x 25 mm	1
18638A	PZ3 x 25 mm	1



BIT T

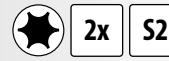

N.p.	specyfikacja	
18827A	T20 x 25 mm	1
18828A	T25 x 25 mm	1
18830A	T30 x 25 mm	1
18831A	T40 x 25 mm	1



BIT PH Z NASYPEM DIAMENTOWYM



N.p.	specyfikacja	
18770	PH1 x 25 mm	5
18771	PH2 x 25 mm	5
18772	PH3 x 25 mm	5



BIT PZ Z NASYPEM DIAMENTOWYM



N.p.	specyfikacja	
18775	PZ1 x 25 mm	5
18776	PZ2 x 25 mm	5
18777	PZ3 x 25 mm	5



BIT S

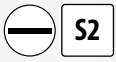

N.p.	specyfikacja	
18620	S 3 x 25 mm	5
18621	S 4 x 25 mm	5
18623	S 5 x 25 mm	5
18625	S 6 x 25 mm	5
18627	S 7 x 25 mm	5
18628	S 8 x 25 mm	5



BIT PH



N.p.	specyfikacja	
18630	PH0 x 25 mm	5
18631	PH1 x 25 mm	5
18632	PH2 x 25 mm	5
18633	PH3 x 25 mm	5
18634	PH4 x 25 mm	5



BIT PZ



N.p.	specyfikacja	
18635	PZ0 x 25 mm	5
18636	PZ1 x 25 mm	5
18637	PZ2 x 25 mm	5
18638	PZ3 x 25 mm	5
18639	PZ4 x 25 mm	5



BIT PH

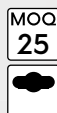

N.p.	specyfikacja	
18685	PH2 x 25 mm	25



BIT PZ



N.p.	specyfikacja	
18680	PZ2 x 25 mm	25



BIT PH



N.p.	specyfikacja	
18640	PH1 x 70 mm	10
18641	PH2 x 70 mm	10



BIT PZ



N.p.	specyfikacja	
18645	PZ1 x 70 mm	10
18646	PZ2 x 70 mm	10



BIT PH

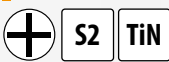

N.p.	specyfikacja	
18760	PH0 x 25 mm	5
18761	PH1 x 25 mm	5
18762	PH2 x 25 mm	5
18763	PH3 x 25 mm	5
18764	PH4 x 25 mm	1



BIT PZ

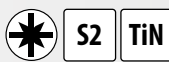

N.p.	specyfikacja	
18765	PZ0 x 25 mm	5
18766	PZ1 x 25 mm	5
18767	PZ2 x 25 mm	5
18768	PZ3 x 25 mm	5
18769	PZ4 x 25 mm	5



BIT S

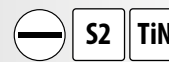

N.p.	specyfikacja	
18750	S 3 x 25 mm	5
18751	S 4 x 25 mm	5
18753	S 5 x 25 mm	5
18755	S 6 x 25 mm	5



BIT H



MOQ 5

N.p.	specyfikacja	
18800	H 1,5 x 25 mm	5
18801	H 2,0 x 25 mm	5
18802	H 2,5 x 25 mm	5
18803	H 3,0 x 25 mm	5
18804	H 4,0 x 25 mm	5
18805	H 5,0 x 25 mm	5
18806	H 5,5 x 25 mm	5
18807	H 6,0 x 25 mm	5



BIT TTA



MOQ 5

N.p.	specyfikacja	
18835	TTa 5 x 25 mm	10
18836	TTa 6 x 25 mm	5
18837	TTa 7 x 25 mm	5
18838	TTa 8 x 25 mm	5
18839	TTa 9 x 25 mm	5
18840	TTa 10 x 25 mm	5
18841	TTa 15 x 25 mm	5
18842	TTa 20 x 25 mm	5
18843	TTa 25 x 25 mm	5
18844	TTa 27 x 25 mm	5
18845	TTa 30 x 25 mm	5
18846	TTa 40 x 25 mm	5
18847	TTa 45 x 25 mm	5



BIT T



MOQ 5

N.p.	specyfikacja	
18820	T5 x 25 mm	5
18821	T6 x 25 mm	5
18822	T7 x 25 mm	5
18823	T8 x 25 mm	5
18824	T9 x 25 mm	5
18825	T10 x 25 mm	5
18826	T15 x 25 mm	5
18827	T20 x 25 mm	5
18828	T25 x 25 mm	5
18829	T27 x 25 mm	5
18830	T30 x 25 mm	5
18831	T40 x 25 mm	5
18832	T45 x 25 mm	5



BIT HTA



MOQ 5

N.p.	specyfikacja	
18810	HTa 1,5 x 25 mm	5
18811	HTa 2,0 x 25 mm	5
18812	HTa 2,5 x 25 mm	5
18813	HTa 3,0 x 25 mm	5
18814	HTa 4,0 x 25 mm	5
18815	HTa 5,0 x 25 mm	5
18816	HTa 5,5 x 25 mm	5
18817	HTa 6,0 x 25 mm	5



BIT SQ



MOQ 5

N.p.	specyfikacja	
18850	SQ 0 x 25 mm	5
18851	SQ 1 x 25 mm	5
18852	SQ 2 x 25 mm	5
18853	SQ 3 x 25 mm	5



BIT T



MOQ 3

Č.p.	specifikace	
17980	T30 x 35 mm	3
17981	T40 x 35 mm	3
17982	T45 x 35 mm	3
17983	T50 x 35 mm	3



BIT SD



MOQ 5

N.p.	specyfikacja	
18855	SD 6 x 25 mm	5
18856	SD 8 x 25 mm	5



BIT T



MOQ 3

N.p.	specyfikacja	
17970	T20 x 75 mm	3
17971	T25 x 75 mm	3
17972	T30 x 75 mm	3
17973	T40 x 75 mm	3

N.p.	specyfikacja	
17974	T45 x 75 mm	3
17975	T50 x 75 mm	3
17976	T55 x 75 mm	3



BIT TS



MOQ 5

N.p.	specyfikacja	
18864	TS 4 x 25 mm	5
18865	TS 6 x 25 mm	5



BIT 5/32', 3/16'



MOQ 5

N.p.	specyfikacja	
18866	5/32 x 25 mm	5
18867	3/16 x 25 mm	5



BIT TW



MOQ 5

N.p.	specyfikacja	
18860	TW 1 x 25 mm	5
18861	TW 2 x 25 mm	5
18862	TW 3 x 25 mm	5
18863	TW 4 x 25 mm	5



BIT XZN



MOQ 5

N.p.	specyfikacja	
18870	M4 x 25 mm	5
18871	M5 x 25 mm	5
18872	M6 x 25 mm	5
18873	M8 x 25 mm	5
18874	M10 x 25 mm	5



BIT ADAPTER

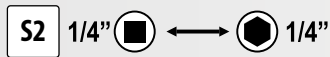

MOQ 5

N.p.	specyfikacja	
18868	25 mm	5



BIT ADAPTER

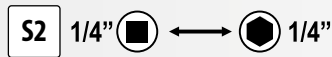

MOQ 5

N.p.	specyfikacja	
18869	50 mm	5



FESTA
INDUSTRY

BIT Z OGRANICZNIKIEM
GŁĘBOKOŚCI



N.p.	specyfikacja	
18795	PH 2 x 25 mm	24



FESTA
INDUSTRY

BIT Z OGRANICZNIKIEM
GŁĘBOKOŚCI



N.p.	specyfikacja	
18796	PH 2 x 55 mm	24



FESTA
INDUSTRY

ADAPTER KWADRAT -
SZEŚCIOKĄT

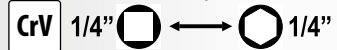

MOQ
5



N.p.	specyfikacja	
18619		5



FESTA
INDUSTRY

UCHWYT MAGNETYCZNY



MOQ
5



N.p.	specyfikacja	
18600	1/4' x 60 mm	5



FESTA
INDUSTRY

UCHWYT MAGNETYCZNY
Z MECHANICZNĄ BLOKADĄ

· szybkie wydanie



MOQ
5



N.p.	specyfikacja	
18601	1/4' x 60 mm	5



FESTA
INDUSTRY

UCHWYT
MAGNETYCZNY
· z ogranicznikiem głębokości



MOQ
5



N.p.	specyfikacja	
18602	1/4' x 60 mm	5



FESTA
INDUSTRY

UCHWYT MAGNETYCZNY



N.p.	specyfikacja	
18797	1/4' x 60 mm	1



FESTA
INDUSTRY

UCHWYT MAGNETYCZNY
Z MECHANICZNĄ BLOKADĄ

· szybkie wydanie

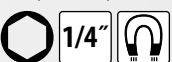

N.p.	specyfikacja	
18798	1/4' x 60 mm	1



FESTA
INDUSTRY

UCHWYT
MAGNETYCZNY
· z ogranicznikiem głębokości

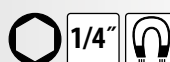

N.p.	specyfikacja	
18799	1/4' x 60 mm	1



FESTA
INDUSTRY

UCHWYT MAGNETYCZNY



N.p.	Specyfikacja	
18605	150 mm	1



FESTA

UCHWYT NA BITY SDS +
NA BITY 1/4"



N.p.	Specyfikacja	
20743	75 mm	1



UCHWYT NA BITY



N.p.	specyfikacja	
18607	80 mm	25

FESTA

UCHWYT
MAGNETYCZNY



N.p. specyfikacja
18609 90mm



25

**WEST
BERG**

UCHWYT
BIT 1/4" - SDS +

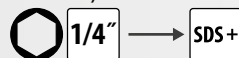

N.p. specyfikacja
20742



1

**FESTA
INDUSTRY**

ZESTAW
KONCÓWEK

- 10x ⊕ 18630 PH0
- 10x ⊕ 18631 PH1
- 10x ⊕ 18632 PH2
- 10x ⊕ 18633 PH3
- 10x ⊕ 18635 PZ0
- 10x ⊕ 18636 PZ1
- 10x ⊕ 18637 PZ2
- 10x ⊕ 18638 PZ3
- 10x ⊕ 18761 PH1 TiN
- 10x ⊕ 18762 PH2 TiN
- 10x ⊕ 18763 PH3 TiN
- 10x ⊕ 18766 PZ1 TiN
- 10x ⊕ 18767 PZ2 TiN
- 10x ⊕ 18768 PZ3 TiN
- 10x ⊕ 18770 PH1 DIAMANT
- 10x ⊕ 18771 PH2 DIAMANT
- 10x ⊕ 18775 PZ1 DIAMANT
- 10x ⊕ 18776 PZ2 DIAMANT
- 10x ⊙ 18814 4,0HTa
- 10x ⊙ 18815 5,0HTa
- 10x ⊕ 18842 20TTa
- 10x ⊕ 18845 30TTa
- 10x ⊕ 18795 PH2 do gipso-kartonu
- 5x 18612 adapter 1/4" 8mm
- 5x 18613 adapter 1/4" 10mm
- 5x 18600 uchwyt magnetyczny 1/4" 60mm
- 5x 18601 uchwyt magnetyczny z mechaniczną blokadą 1/4" 60mm
- 5x 18602 uchwyt magnetyczny z ogranicznikiem głębokości 1/4" 65mm

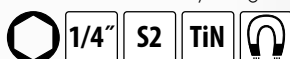

N.p. specyfikacja
18993

1

**FESTA
INDUSTRY**

ZESTAW
KONCÓWEK

- 10x ⊕ 18631 PH1
- 10x ⊕ 18632 PH2
- 10x ⊕ 18633 PH3
- 10x ⊕ 18636 PZ1
- 10x ⊕ 18637 PZ2
- 10x ⊕ 18638 PZ3
- 10x ⊕ 18761 PH1 TiN
- 10x ⊕ 18762 PH2 TiN
- 10x ⊕ 18763 PH3 TiN
- 10x ⊕ 18766 PZ1 TiN
- 10x ⊕ 18767 PZ2 TiN
- 10x ⊕ 18768 PZ3 TiN
- 10x ⊙ 18804 H 4
- 10x ⊙ 18805 H 5
- 10x ⊙ 18825 T 10
- 10x ⊙ 18826 T 15
- 10x ⊙ 18827 T 20
- 10x ⊙ 18828 T 25
- 10x ⊙ 18830 T 30
- 10x ⊙ 18831 T 40

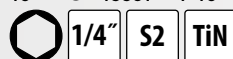

N.p. specyfikacja
18994

1

**FESTA
INDUSTRY**

KOŃCÓWKA DO
ŚRUB FARMERSKICH

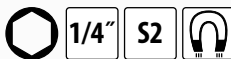

N.p. specyfikacja
18610 6 mm 5
18611 7 mm 5
18612 8 mm 5

MOQ
5



**FESTA
INDUSTRY**

KOŃCÓWKA DO
ŚRUB FARMERSKICH

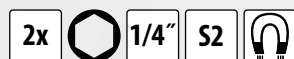

N.p. specyfikacja
18610A 6 mm 5
18611A 7 mm 5
18612A 8 mm 5



N.p. specyfikacja
18613A 10 mm 5
18614A 12 mm 5
18615A 13 mm 5

FESTA

KOMPLET KOŃCÓWEK MAGNETYCZNYCH

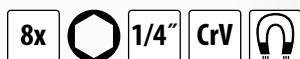

N.p. specyfikacja
18618 6, 7, 8, 9, 10, 11, 12, 13 mm



12





FESTA

ZESTAW KOŃCÓWEK

- bit 25 mm
- ⊖ S 3 · 4 · 5 · 6
 - ⊕ PH 0 · 1 · 2 · 3
 - ⊕ PZ 0 · 1 · 2 · 3
 - ⊕ H 3 · 4 · 5 · 6
 - ⊕ T 10 · 15 · 20 · 25 · 27 · 30 · 40
 - ⊕ TTa 10 · 15 · 20 · 25 · 27 · 30 · 40

uchwyt

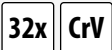

N.p. specyfikacja
18908

1



FESTA

ZESTAW KOŃCÓWEK

- ⊕ S 3 · 4 · 5 · 6
 - ⊕ PH 1 · 2 · 3
 - ⊖ PZ 1 · 2 · 3
 - ⊕ H 3 · 4 · 5 · 6
 - ⊕ T 10 · 15 · 20 · 25 · 27 · 30 · 40
 - ⊕ TTa 10 · 15 · 20 · 25 · 27 · 30 · 40
- uchwyt magnetyczny z mechaniczną blokadą

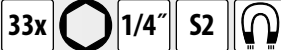

N.p. specyfikacja
18905



FESTA

ZESTAW KOŃCÓWEK

- ⊕ S 4 · 5 · 6
 - ⊖ PH 1 · 2 · 3
 - ⊕ PZ 1 · 2 · 3
 - ⊕ H 3 · 4 · 5 · 6
 - ⊕ T 10 · 15 · 20 · 25 · 27 · 30 · 40
 - ⊕ TTa 10 · 15 · 20 · 25 · 27 · 30 · 40
- uchwyt magnetyczny z mechaniczną blokadą

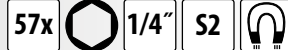

N.p. specyfikacja
18906



6

FESTA

ZESTAW KOŃCÓWEK

- ⊕ HTa 2 · 2.5 · 3 · 4 · 5 · 6
5/32" · 9/64" · 1/8"
7/64" · 3/32" · 5/64"
- ⊕ SD 4 · 6 · 8 · 10
- ⊕ TS 6 · 8 · 10
- ⊕ TW 1 · 2 · 3 · 4
- ⊕ TTa 8 · 10 · 15 · 20 · 25 · 27 · 30 · 35 · 40

uchwyt magnetyczny



N.p. specyfikacja
18900



10

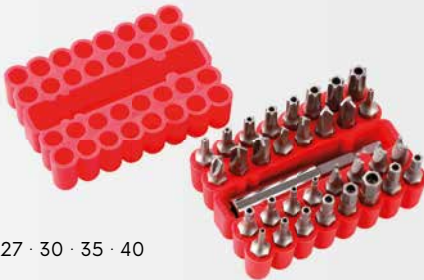

FESTA

ZESTAW KOŃCÓWEK

- ⊕ S 3 · 4 · 4.5 · 5 · 5.5 · 6 · 6.5 · 7 · 8
- ⊕ PH 0 · 1 · 2 · 3
- ⊕ PZ 0 · 1 · 2 · 3
- ⊕ Q 0 · 1 · 2 · 3
- ⊕ 8 · 10 · 15 · 20 · 25 · 27 · 30 · 40 · 45
- ⊕ TTa 8 · 10 · 15 · 20 · 25 · 27 · 30 · 35 · 40
- ⊕ H 1.5 · 2 · 2.5 · 3 · 4 · 5 · 5.5 · 6 · 8 mm
1/16" · 5/64" · 3/32" · 7/64" · 1/8" · 9/64"
5/32" · 3/16" · 7/32" · 1/4"
- ⊕ HTa 2 · 2.5 · 3 · 4 · 5 · 6 mm
5/64" · 3/32" · 7/64" · 1/8" · 9/64" · 5/32"
- ⊕ SD 4 · 6 · 8 · 10
- ⊕ TS 6 · 8 · 10
- ⊕ TW 1 · 2 · 3 · 4
- ⊕ 2-wing 1 · 2 · 3
- ⊕ XZN 5 · 6 · 8

uchwyt magnetyczny

nasadka „Y”
1/4" DR nasadka na wkrętak
1/4" bit adapter: 25mm, 50mm



N.p. specyfikacja
18909



24



FESTA

ZESTAW KOŃCÓWEK

- ⊖ S 3 · 4 · 5 · 6 · 7
- ⊕ PH 0 · 1 · 2 · 3
- ⊕ PZ 1 · 2 · 3
- ⊕ H 2 · 2.5 · 3 · 4 · 5 · 6
- ⊕ T 10 · 15 · 20 · 25 · 30 · 40

uchwyt magnetyczny



N.p. specyfikacja
18901



10



ZESTAW KOŃCÓWEK

- ⊖ S 4 · 5 · 6 · 7
- ⊕ PH 1 · 2 · 3
- ⊛ PZ 1 · 2 · 3
- H 4 · 5 · 6
- ⊛ T 10 · 15 · 20 · 25
- SQ 1 · 2 · 3

20x S2



10x CrV TiN

N.p. specyfikacja
18907 10



ZESTAW KOŃCÓWEK

- ⊖ S 4 · 5 · 6 · 7
- ⊕ PH 1 · 2 · 3
- ⊛ PZ 1 · 2 · 3

10x CrV TiN

N.p. specyfikacja
18440 10

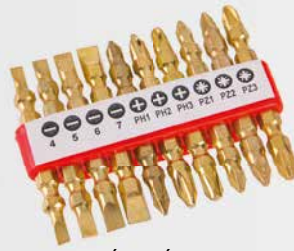

ZESTAW KOŃCÓWEK

- ⊖ S 3 · 5 · 7
 - ⊕ PH 1 · 2 · 3
- uchwyt magnetyczny

7x HOBBY

N.p. specyfikacja
18430 20



ZESTAW BITÓW I NASADEK

- ⊕ S 3 · 3,5 · 4 · 5,5
 - ⊛ PH 0 · 1 · 2 · 3
 - ⊖ PZ 0 · 1 · 2 · 3
 - H 3 · 4
 - ⊛ T 10 · 15 · 20 · 25 · 27 · 30
 - 1/4" 4 · 4,5 · 5 · 5,5 · 6 · 7 · 8 · 9 · 10 · 11 · 13
- nasadka na wkrętak 1/4"
uchwyt magnetyczny

CrV 1/4"

40x



N.p. specyfikacja
18915 10



ZESTAW NARZĘDZI

- ⊖ S 5 · 6 mm
- ⊕ PH 1 · 2
- H 3 · 4 · 5 · 6
- ⊛ T 15 · 20 · 25 · 30
- 1/4" 4 · 5 · 6 · 7 · 8 · 9 · 10 · 12 · 13 mm

75 mm 1/4" 1/4" ↔ 1/4"

1/4" CrV

23x

N.p. specyfikacja
18421 10





- 1/2", 1/4"
- 1/4" · 4-5-6-7-8-9mm
- 1/2" · 10-12-13-14-17-19mm
- 1/4" · 4-4.5-5-5.5-6-7-8-9-10-11-12-13-14mm
- 1/2" · 12-13-14-15-16-17-18-19-20-21-22-24mm
- 1/2", 1/4"
- 1/4" 1/4"
- 1/4" · 150mm
- 1/2" · 254mm
- 1/2", 1/4"
- 1/2" · 16-21mm
- 1/4" · 150mm
- 1/2" · E10-E12-E14-E16-E18-E20-E22-E24
- 1/4" S 3 · 4 · 5 · 6
- 1/4" PH 0 · 1 · 2
- 1/4" PZ 0 · 1 · 2
- 1/4"
- 1/4" · S 4 · 5,5 · 6,5
- 1/4" PH 1 · 2 · 3
- 1/4" PZ 2 · 3
- 1/4" H 3 · 4 · 5 · 6
- 1/4" T 8 · 10 · 15 · 20 · 25
- 1/4" TTa 10 · 15 · 20 · 25 · 40
- 2 · 2,5 · 3 · 4 · 5 · 6 · 7 · 8 · 10mm
- 8-9-10-11-12-13-14-15-16-17-18-19mm
- S 4x100 · 6,5x150
- PH 2x100 · 3x150
- 180mm
- 160mm
- 160mm
- 250mm
- 300g

FESTA

ZESTAW NARZĘDZI

122x CrV S2 1/4" 1/2" 72T

N.p. specyfikacja
17238 122 szt.



1



ZESTAW NARZĘDZI

- 160 mm
- 160 mm
- 300 g
- 1/4" 45T
- 4 · 5 · 6 · 7 · 8 · 9 · 10 · 11 · 12 · 13 mm
- 1/4" 75 mm
- 1,5 · 2 · 2,5 · 3 · 4 · 5 · 6 · 8 · 10 mm
- S 3 · 4 · 5 · 6 mm
- PH 0 · 1 · 2 · 3
- PZ 0 · 1 · 2 · 3
- T 10 · 15 · 20 · 25
- H 3 · 4 · 5 · 6
- S 5x100 mm
- PH 1x100 · 2x100 mm
- S 2,5x50 mm
- PH 00x50 · 0x50 mm
- AC 100-250 V
- 200 mm max. 22 mm
- 10x11 · 12x13 · 14x15 · 16x17 mm
- 18 mm
- 2 mm 13 mm

60x



35x

N.p. specyfikacja
17259 5

5



ZESTAW NARZĘDZI

- 120mm
- 125mm
- 115mm
- 150mm max. 19mm
- 9mm
- 9mm
- 1/4" 160mm
- 5 · 6 · 7 · 8 · 9 · 10 · 11 mm
- 1/4"
- 1/4"
- S 4 · 6 mm
- PH 1 · 2 · 3
- PZ 1 · 2
- H 4 · 5 · 6

35x

N.p. specyfikacja
17260 10

10



ZESTAW NARZĘDZI

- 1/4" 5 · 6 · 7 · 8 · 9 · 10 · 11 · 12 mm
- 1/4"
- 1/4"
- AC 230 V
- PH 0, SL 3
- 9x 1,5-10 mm
- 160 mm
- S 3 · 4 · 5 · 6 mm
- PH 0 · 1 · 2 · 3
- H 4 · 5
- PH 2x100, S 6x100
- 18 mm
- 1 m
- 300 g

39x



N.p. specyfikacja
17247 10

10

FESTA

10 years
guarantee



Cr-Mo

- Zastosowanie przemysłowe i serwisowe
- Wysokiej jakości stal chromowo-wanadowa
- Grzechotka z 72-zębami do najdokładniejszej pracy
- Wszystkie elementy zgodne z normami DIN
- Głowice radełkowane dla lepszego chwytu
- Wytrzymała walizka z metalowymi zamkami i zawiasami



FESTA

ZESTAW KLUCZY

- 1/2", 1/4", 3/8"
- 1/4" · 4-5-6-7-8-9-10mm
- 3/8" · 10-11-12-13-14-15mm
- 1/2" · 16-17-18-19-22mm
- 1/4" · 4-4.5-5-5.5-6-7-8-9-10-11-12-13-14mm
- 3/8" · 10-11-12-13-14-15-16-17-18-19mm
- 1/2" · 10-11-12-13-14-15-16-17-18-19-20-21-22-24-27-30-32mm
- 1/4" · E4-E5-E6-E7-E8
- 3/8" · E10-E11-E12-E14-E16-E18
- 1/2" · E20-E24
- 1/2" · 24x
- 1/4" · 20x
- 1/4" · 30x
- 1/4" · 50 mm, 100 mm
- 1/2" · 125 mm, 250 mm
- 3/8" · 150 mm
- 1/2" · 16-21mm
- 3/8" · 18mm
- 1/2", 1/4", 3/8" bit holder
- 1/2", 1/4", 3/8"
- 1/4" · 150mm
- 1/4" · 115mm
- Inbus 7X



10 years
guarantee



CrV S2 1/4" 1/2" 3/8" 72T 171x ERGO HANDLE

N.p. specyfikacja
17237

2



FESTA

ZESTAW KLUCZY

- 1/2" · 72T
- 1/2" · 125 mm
- 1/2" · 10-11-12-13-14-15-17-19-22-24 mm

10 years guarantee



Ć.p. specyfikacje 17245 15



FESTA

ZESTAW KLUCZY

- 1/2" · 72T
- 1/2" · 125 mm
- 1/2" · 10-11-12-13-14-15-17-19-22-24 mm

10 years guarantee



Ć.p. specyfikacje 17229 8



FESTA

ZESTAW KLUCZY

- 1/2" · 72 T
- 1/2" · 75, 125 mm
- 1/2"
- 1/2" · 10-11-12-13-14-15-16-17-18-19-22-24 mm
- 1/2" · 17mm, 19mm
- 3 way adapter
- 16mm, 21mm

10 years guarantee



Ć.p. specyfikacje 17230 4



FESTA

ZESTAW KLUCZY

- 1/4" · 72 T
- 1/4" · 50, 100 mm
- 1/4"
- 1/4" · 4-5-5.5-6-7-8-10-11-12-13 mm
- 1/4" · 6-7-8-10-12-13 mm
- 3 way adapter
- 4 x
- 11x
- 1x

10 years guarantee

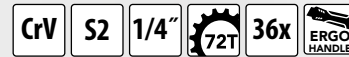

Ć.p. specyfikacje 17231 10



FESTA

ZESTAW KLUCZY

- 1/4"
- 1/4"
- 1/4" · 4-4.5-5-5.5-6-7-8-9-10-11-12-13-14 mm
- 1/4" · 50 mm, 100 mm
- 1/4"
- 1/4"
- 21 x
- 1/4"
- L 1/4"

10 years guarantee



Ć.p. specyfikacje 17233 10



FESTA

ZESTAW KLUCZY

- 1/2", 1/4" · 72T
- 1/4"
- 16 mm, 21 mm
- 1/4" · 10-11-12-13-14-15-16-17-18-19-20-21-22-23-24-27 mm
- 1/4" · 100 mm
- 1/2" · 125 mm, 250 mm
- 1/4"
- 1x
- 1/4" · 4-5-5.5-6-7-8-10-11-12-13 mm
- 33 x



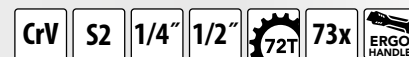







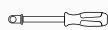



10 years guarantee

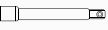

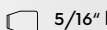
Ć.p. specyfikacje 17234 4

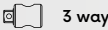
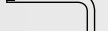
FESTA

ZESTAW KLUCZY

-  1/2", 1/4" · 72T
-  1/4"
-  16 mm, 21 mm
-  1/4" · 4 -4,5-5-5,5-6-7-8-9-10-11-12-13-14 mm
-  1/2" · 10-11-12-13-14-15-16-17-18-19-20-21-22-23-24-27-30-32 mm
-  1/4" · 6-7-8-9-10-11-12-13 mm
-  1/2" · 14-15-17-19 mm
-  1/4" · 50 mm, 100 mm
-  1/2" · 125 mm, 250 mm
-  1/4"
-  5/16" bit holder
-  17x
-  15x
-  3 way adapter
-  3 x
-  1/4"
-  L 1/4"
-  1/2", 1/4"

CrV S2 1/4" 1/2" 72T 94x ERGO HANDLE













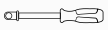

10 years guarantee

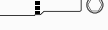

Č.p.	specifikace
17235	4

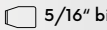
FESTA

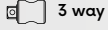
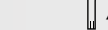
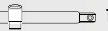
ZESTAW KLUCZY

-  1/2", 1/4" · 72T
-  150 mm
-  16 mm, 21 mm
-  1/4" · 4 -4,5-5-5,5-6-7-8-9-10-11-12-13-14 mm
-  1/2" · 10-11-12-13-14-15-16-17-18-19-20-21-22-24-27-30-32 mm
-  1/4" · 6-7-8-9-10-11-12-13 mm
-  1/2" · 14-15-17-19-22 mm
-  1/4" · 50 mm, 100 mm
-  1/2" · 125 mm, 250 mm
-  E · 4-5-6-7-8-10-11-12-14-16-18-20-24-27-30-32 mm
-  1/2", 1/4"
-  5/16" bit holder
-  18 x
-  17 x
-  3 way adapter
-  4 x
-  1/4"
-  L 1/4"

CrV S2 1/4" 1/2" 72T 110x ERGO HANDLE













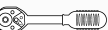









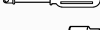









10 years guarantee



Č.p.	specifikace
17236	4

FESTA

ZESTAW NARZĘDZI

-  1/2", 1/4"
-  1/4" · 4-5-6-7-8-9mm
-  1/2" · 10-12-13-14-17-19mm
-  1/4" · 4-4,5-5-5,5-6-7-8-9-10-11-12-13-14mm
-  1/2" · 12-13-14-15-16-17-18-19-20-21-22-24mm
-  1/2", 1/4"
-  1/4" · 4-5-6-7-8-9-10-11-12-13-14mm
-  1/4" · 150mm
-  1/2" · 254mm
-  1/2", 1/4"
-  1/2" · 16-21mm
-  1/4" · 150mm
-  1/2" · E10-E12-E14-E16-E18-E20-E22-E24
-  1/4" · S 3 · 4 · 5 · 6
-  1/4" · PH 0 · 1 · 2
-  1/4" · PZ 0 · 1 · 2
-  1/4" · S 4 · 5,5 · 6,5
-  1/4" · PH 1 · 2 · 3
-  1/4" · PZ 2 · 3
-  1/4" · H 3 · 4 · 5 · 6
-  1/4" · T 8 · 10 · 15 · 20 · 25
-  1/4" · TTα 10 · 15 · 20 · 25 · 40
-  2 · 2,5 · 3 · 4 · 5 · 6 · 7 · 8 · 10mm
-  8-9-10-11-12-13-14-15-16-17-18-19mm
-  S 4x100 · 6,5x150
-  PH 2x100 · 3x150
-  180mm
-  160mm
-  160mm
-  250mm
-  300g

CrV S2 1/4" 1/2" 72T 122x ERGO HANDLE



Č.p.	specifikace
17238	122 ks 1



FESTA



FESTA



GRZECHOTKA FESTA

- Grzechotka wykonana jest z najwyższej jakości stali chromowananaowej
- Grzechotka z 72 polerowanymi zębami do najdokładniejszej pracy
- Jakościowy ergonomiczny, ówuskladnikowy uchwyt z miękkiej TPE gummy
- SYSTEM QUICK RELEASE dla łatwej i szybkiej wymiany głowic



FESTA

GRZECHOTKA



Ć.p.	specyfikacje	długość	opakowanie
17297	1/4"	155 mm	6
17298	3/8"	210 mm	5
17299	1/2"	255 mm	4

FESTA

GRZECHOTKA



Ć.p.	specyfikacje	długość	opakowanie
17240	1/4"	155 mm	10
17241	3/8"	200 mm	10
17242	1/2"	250 mm	5

FESTA

GRZECHOTKA



Ć.p.	specyfikacje	długość	opakowanie
17294	1/4"	155 mm	6
17295	3/8"	205 mm	10
17296	1/2"	255 mm	4

FESTA

GRZECHOTKA 1/4"



Ć.p.	specyfikacje	opakowanie
17292	1/4"	1

GRZECHOTKA

HOBBY



Ć.p.	specyfikacje	opakowanie
17243	1/4" 43T	25
17244	1/2" 39T	25

FESTA

WKRĘTAK DO NĄSADEK

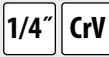

Ć.p.	specyfikacje	opakowanie
18603	1/4" 150 mm	10



FESTA

NASADKA 1/4"



Č.p.	specifikace	
17820	4 mm • 25 mm	10
17821	4,5 mm • 25 mm	10
17822	5 mm • 25 mm	10
17823	5,5 mm • 25 mm	10
17824	6 mm • 25 mm	10
17825	7 mm • 25 mm	10
17826	8 mm • 25 mm	10
17827	9 mm • 25 mm	10
17828	10 mm • 25 mm	10
17829	11 mm • 25 mm	10
17830	12 mm • 25 mm	10
17831	13 mm • 25 mm	10
17832	14 mm • 25 mm	10



FESTA

NASADKA 1/2"



Č.p.	specifikace	
17308	8 mm • 38 mm	10
17309	9 mm • 38 mm	10
17310	10 mm • 38 mm	10
17311	11 mm • 38 mm	10
17312	12 mm • 38 mm	10
17313	13 mm • 38 mm	10
17314	14 mm • 38 mm	10
17315	15 mm • 38 mm	10
17316	16 mm • 38 mm	10
17317	17 mm • 38 mm	10
17318	18 mm • 38 mm	10
17319	19 mm • 38 mm	10
17320	20 mm • 38 mm	10
17321	21 mm • 38 mm	10
17322	22 mm • 38 mm	10
17324	24 mm • 38 mm	10
17327	27 mm • 42 mm	20
17330	30 mm • 42 mm	25
17332	32 mm • 42 mm	20
17333	34 mm • 42 mm	20
17334	36 mm • 42 mm	20



FESTA

NASADKA 3/4"



Č.p.	specifikace	
17835	17 mm • 48 mm	10
17836	18 mm • 48 mm	10
17837	19 mm • 48 mm	10
17838	21 mm • 48 mm	10
17839	22 mm • 48 mm	10
17840	24 mm • 48 mm	10
17841	26 mm • 48 mm	10
17842	27 mm • 52 mm	10
17843	28 mm • 52 mm	10
17844	30 mm • 52 mm	10
17845	32 mm • 52 mm	10
17846	33 mm • 55 mm	10
17847	36 mm • 60 mm	10
17848	38 mm • 60 mm	10
17849	41 mm • 65 mm	10
17850	46 mm • 65 mm	10
17851	50 mm • 70 mm	10
17852	55 mm • 75 mm	10
17853	60 mm • 78 mm	10
17854	65 mm • 82 mm	10
17855	70 mm • 82 mm	10
17856	75 mm • 88 mm	10



FESTA

NASADKA MULTILOCK 1/2"



Č.p.	specifikace	
17910	8 mm • 38 mm	10
17914	12 mm • 38 mm	10
17916	14 mm • 38 mm	10
17922	21 mm • 38 mm	10
17924	24 mm • 38 mm	10
17926	30 mm • 38 mm	10



FESTA

NASADKA WYDŁUŻONA 1/4"



Č.p.	specifikace	
17860	4 mm • 50 mm	10
17861	5 mm • 50 mm	10
17862	6 mm • 50 mm	10
17863	7 mm • 50 mm	10
17864	8 mm • 50 mm	10
17865	9 mm • 50 mm	10
17866	10 mm • 50 mm	10
17867	11 mm • 50 mm	10
17868	12 mm • 50 mm	10
17869	13 mm • 50 mm	10
17870	14 mm • 50 mm	10

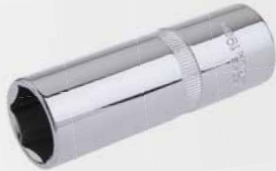

FESTA

NASADKA WYDŁUŻONA 1/2"



Č.p.	specifikace	
17871	10 mm • 70 mm	10
17872	11 mm • 70 mm	10
17873	12 mm • 70 mm	10
17874	13 mm • 70 mm	10
17875	14 mm • 70 mm	10
17876	15 mm • 70 mm	10
17877	16 mm • 70 mm	10
17878	17 mm • 70 mm	10
17879	18 mm • 70 mm	10
17880	19 mm • 70 mm	10
17881	20 mm • 70 mm	10
17882	21 mm • 70 mm	10
17883	22 mm • 70 mm	10
17884	23 mm • 70 mm	10
17885	24 mm • 70 mm	10
17886	25 mm • 70 mm	10
17887	26 mm • 70 mm	10
17888	27 mm • 70 mm	10
17889	28 mm • 70 mm	10
17890	30 mm • 70 mm	10
17891	32 mm • 70 mm	10
17892	34 mm • 70 mm	10



FESTA

NASADKA TORX 1/2"



Č.p.	specifikace	
17943	E22	10
17944	E24	10



FESTA

NASADKA TORX 1/4"



Č.p.	specifikace	
17930	E4	10
17934	E8	10
17935	E10	10



FESTA

NASADKA MULTILOCK 1/4"



Č.p.	specifikace	
17895	4 mm • 25 mm	10
17896	4,5 mm • 25 mm	10
17897	5 mm • 25 mm	10
17898	5,5 mm • 25 mm	10
17904	11 mm • 25 mm	10
17905	12 mm • 25 mm	10
17907	14 mm • 25 mm	10





FESTA

NASADKA
Z BITEM 1/4"

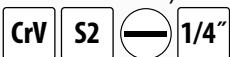

Č.p.	specifikace	
18920	S 4 mm	10
18921	S 5,5 mm	10
18922	S 7 mm	10



FESTA

NASADKA
Z BITEM 1/4"

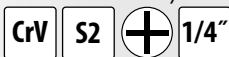

Č.p.	specifikace	
18925	PH 1	10
18926	PH 2	10
18927	PH 3	10



FESTA

NASADKA
Z BITEM 1/4"



Č.p.	specifikace	
18928	PZ 0	10
18929	PZ 1	10
18930	PZ 2	10
18931	PZ 3	10



FESTA

NASADKA
Z BITEM 1/2"



Č.p.	specifikace	
18954	T 10	10
18955	T 15	10
18956	T 20	10
18960	T 40	10
18961	T 45	10
18963	T 55	10



FESTA

NASADKA
Z BITEM 1/4"



Č.p.	specifikace	
18948	T 5	10
18950	T 8	10
18951	T 10	10



FESTA

NASADKA
Z BITEM 1/4"



Č.p.	specifikace	
18934	3 mm	10
18939	8 mm	10



FESTA

NASADKA
Z BITEM 1/2"



Č.p.	specifikace	
18971	M 16	10



FESTA

ADAPTER
Z OTVOREM
NA PRZEDŁUŻKĘ



Č.p.	specifikace	
17420	1/4"	1
17421	1/2"	1
17422	3/4"	1



FESTA

ADAPTERY
DO NASADEK



Č.p.	specifikace	
17410	A - 1/4" B - 3/8"	10
17411	A - 3/8" B - 1/4"	10
17412	A - 3/8" B - 1/2"	10
17413	A - 1/2" B - 3/8"	10
17414	A - 1/2" B - 3/4"	10
17415	A - 3/4" B - 1/2"	10
17416	A - 1/4" B - 1/2"	10



FESTA

PRZEDŁUŻKA



Č.p.	specifikace	
17390	1/4" • 50 mm	1
17391	1/4" • 100 mm	1
17392	1/4" • 150 mm	1
17393	1/2" • 75 mm	1
17394	1/2" • 125 mm	1
17395	1/2" • 250 mm	1
17396	3/4" • 100 mm	1
17397	3/4" • 200 mm	1
17398	3/4" • 400 mm	1



FESTA

PRZEGUB CARDANA



Č.p.	specifikace	
17405	1/4" • 39 mm	10
17406	1/2" • 71 mm	10
17407	3/4" • 105 mm	10

FESTA

RĘKOJEŚĆ
PRZESUWNA „T”



Č.p.	specifikace	
17382	1/4" • 115 mm	1
17383	3/8" • 190 mm	1
17384	1/2" • 250 mm	1
17385	3/4" • 460 mm	1
17386	1" • 640 mm	1



FESTA

RĘKOJEŚĆ „T”
UCHYLNÁ



Č.p.	specifikace	
17401	1/4" • 250 mm	1
17402	1/2" • 400 mm	1





FESTA

REKOJEŚĆ UCHYLNA

CrV

N.p.	specyfikacja	
17380	1/2" • 350 mm	1
17381	3/4" • 500 mm	1



FESTA

POKRĘTŁO L

CrV 1/2"

N.p.	specyfikacja	
17427	1/2" • 60 x 320 mm	1



FESTA

PRZEDŁUŻKA GIĘTKA

CrV 1/4"

N.p.	specyfikacja	
17400	1/4" • 150 mm	1

Stahlberg

ADAPTER KWADRAT - SZEŚCIOKĄT

CrV

1/4" 1/4"

N.p.	specyfikacja	
18619		5



NASADKA UNIWERSALNA

CrV 1/2"

N.p.	Specyfikacja	
17812	10 - 19 mm	1



NASADKA UNIWERSALNA

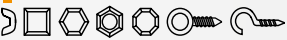

CrV 3/8"

N.p.	specyfikacja	
17810	rozmiar 7 - 19mm • 52mm x ø26mm	1



NASADKA UNIWERSALNA

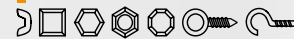

CrV 1/2"

N.p.	specyfikacja	
17811	rozmiar 11 - 32mm • 83mm x ø43mm	5



ZESTAW NASADEK DRIVELOCK

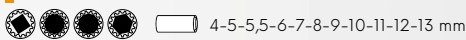

CrV 1/4" 12x

Č.p.	specifikace	
17250	4-5-5,5-6-7-8-9-10-11-12-13 mm	10



ZESTAW NASADEK TORX

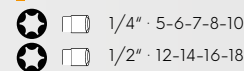

CrV 1/2" 1/4" 9x

Č.p.	specifikace	
17255	1/4" • 5-6-7-8-10 1/2" • 12-14-16-18	4



ZESTAW ADAPTERÓW DO WIERTARKI

CrV 1/4" 3x

N.p.	specyfikacja	
18604	1/4", 3/8", 1/2"	10



FESTA

KLUCZ DO ZAWORÓW GRZEJNIKOWYCH

CrV 1/2"

N.p.	specyfikacja	
17455	pro ráčnu 1/2"	10



21 mm
16 mm
1/2"
7/16"
3/8"

NEW



FESTA

ZESTAW WKREŃTAKÓW T INBUS + TORX

- H 2.5 · 3 · 4 · 5 · 6 · 8 · 10 mm
- ★ T 10 · 15 · 20 · 25 · 30 · 40 · 45

14x CrV



N.p. specyfikacja
18501

1

FESTA

ZESTAW WKREŃTAKÓW T - HEX

- 2 mm
- 2,5 mm
- 3 mm
- 4 mm
- 5 mm
- 6 mm
- 7 mm
- 8 mm
- 10 mm

9x **CrV**

N.p. specyfikacja
18494

6



FESTA

WKREŃTAK T TORX

★ CrV



N.p.	specyfikacja	
17350	T 7	10
17351	T 8	10
17352	T 9	10
17353	T 10	10

N.p.	specyfikacja	
17357	T 27	10
17359	T 40	10
17361	T 50	10

FESTA

ZESTAW WKREŃTAKÓW T - TORX

- T 10
- T 15
- T 20
- T 25
- T 27
- T 30
- T 40
- T 45
- T 50

9x **CrV**

N.p. specyfikacja
18495

6



FESTA

INBUS - STANDARD

DIN 911 **CrV**



Č.p.	specifikace	
18567	27 mm 100 x 250 mm	1
18572	32 mm 125 x 315 mm	1

FESTA

INBUS - DŁUGIE

CrV

Č.p.	specifikace	
18510	1,5 mm 14 x 74 mm	1
18511	2 mm 16 x 81 mm	1
18512	2,5 mm 18 x 88 mm	1
18513	3 mm 23 x 108 mm	1
18514	4 mm 24 x 107 mm	1
18515	5 mm 23 x 118 mm	1
18516	6 mm 32 x 135 mm	1
18518	8 mm 36 x 153 mm	1
18519	9 mm 38 x 155 mm	1
18520	10 mm 40 x 168 mm	1
18521	11 mm 40 x 230 mm	1
18522	12 mm 45 x 237 mm	1
18523	13 mm 45 x 260 mm	1
18524	14 mm 55 x 265 mm	1
18527	17 mm 60 x 298 mm	1

FESTA

INBUS Z KULKĄ

CrV

Č.p.	specifikace	
18575	1,5 mm 15 x 75 mm	1
18576	2 mm 17 x 81 mm	1
18577	2,5 mm 18 x 87 mm	1
18578	3 mm 20 x 96 mm	1
18579	4 mm 24 x 107 mm	1
18580	5 mm 30 x 120 mm	1
18581	6 mm 33 x 136 mm	1
18582	7 mm 34 x 144 mm	1
18583	8 mm 36 x 153 mm	1
18584	9 mm 38 x 155 mm	1
18585	10 mm 40 x 168 mm	1
18587	12 mm 45 x 237 mm	1
18588	13 mm 45 x 210 mm	1
18589	14 mm 55 x 265 mm	1
18593	17 mm 60 x 298 mm	1

FESTA

TORX

★ CrV



Č.p.	specifikace	
18476	T45	1

FESTA

ZESTAW KLUCZY
SZEŚCIOKĄTNYCH

- H 1,5 mm
- H 2 mm
- H 2,5 mm
- H 3 mm
- H 4 mm
- H 5 mm
- H 6 mm
- H 8 mm
- H 10 mm



N.p. specyfikacja
18496



5

FESTA

ZESTAW KLUCZY
SZEŚCIOKĄTNYCH Z KULKĄ

- H 1,5 mm
- H 2 mm
- H 2,5 mm
- H 3 mm
- H 4 mm
- H 5 mm
- H 6 mm
- H 8 mm
- H 10 mm



N.p. specyfikacja
18500



5

FESTA

ZESTAW KLUCZY
SZEŚCIOKĄTNYCH - DŁUGIE

- H 1,5 mm
- H 2 mm
- H 2,5 mm
- H 3 mm
- H 4 mm
- H 5 mm
- H 6 mm
- H 8 mm
- H 10 mm



N.p. specyfikacja
18490



5

FESTA

ZESTAW KLUCZY
SZEŚCIOKĄTNYCH - Z KULKĄ

- H 1,5 mm
- H 2 mm
- H 2,5 mm
- H 3 mm
- H 4 mm
- H 5 mm
- H 6 mm
- H 8 mm
- H 10 mm



N.p. specyfikacja
18498



5

FESTA

ZESTAW KLUCZY SZEŚCIOKĄTNYCH
- Z KULKĄ

- 1/16"
- 5/64"
- 3/32"
- 1/8"
- 5/32"
- 3/16"
- 1/4"
- 5/16"
- 3/8"



N.p. specyfikacja
18493



6

FESTA

ZESTAW KLUCZY
SZEŚCIOKĄTNYCH TORX

- T 10 mm
- T 15 mm
- T 20 mm
- T 25 mm
- T 27 mm
- T 30 mm
- T 40 mm
- T 45 mm
- T 50 mm



N.p. specyfikacja
18497



5

FESTA

ZESTAW KLUCZY SZEŚCIOKĄTNYCH
- Z KULKĄ DŁUGIE

- H 1,5 mm
- H 2 mm
- H 2,5 mm
- H 3 mm
- H 4 mm
- H 5 mm
- H 6 mm
- H 8 mm
- H 10 mm



N.p. specyfikacja
18492



10

FESTA

ZESTAW KLUCZY SZEŚCIOKĄTNYCH
TORX - DŁUGIE

- T 10 mm
- T 15 mm
- T 20 mm
- T 25 mm
- T 27 mm
- T 30 mm
- T 40 mm
- T 45 mm
- T 50 mm



N.p. specyfikacja
18491



5

FESTA

ZESTAW KLUCZY
SZEŚCIOKĄTNYCH



N.p. specyfikacja
18508 1,5 · 2 · 2,5 · 3 · 4 · 5 · 6 mm



1

ZESTAW KLUCZY
SZEŚCIOKĄTNYCH



8x
N.p. specyfikacja
18499 2 · 2,5 · 3 · 4 · 5 · 6 · 8 · 10 mm



1

FESTA

KLUCZE PŁASKIE

CrV DIN 3110



N.p.	specyfikacja	
17550	6 x 7 mm	10
17551	8 x 9 mm	10
17552	8 x 10 mm	10
17553	10 x 11 mm	10
17590	10 x 13 mm	10
17554	12 x 13 mm	10
17555	14 x 15 mm	10
17556	13 x 16 mm	10
17557	13 x 17 mm	10
17591	14 x 17 mm	10
17558	16 x 17 mm	10
17559	17 x 19 mm	10
17560	18 x 19 mm	10

N.p.	specyfikacja	
17592	19 x 22 mm	10
17593	19 x 24 mm	10
17561	20 x 22 mm	10
17569	21 x 23 mm	10
17548	22 x 24 mm	10
17562	24 x 27 mm	10
17549	24 x 30 mm	10
17563	30 x 32 mm	10
17564	30 x 34 mm	10
17565	32 x 36 mm	10
17566	36 x 41 mm	10
17567	46 x 50 mm	10
17568	50 x 55 mm	3

FESTA

KLUCZE PŁASKO – OCZKOWE

CrV DIN 3113



N.p.	specyfikacja	
17487	6 mm	10
17570	7 mm	10
17571	8 mm	10
17572	9 mm	10
17573	10 mm	10
17574	11 mm	10
17575	12 mm	10
17576	13 mm	10
17577	14 mm	10
17578	15 mm	10
17579	16 mm	10
17580	17 mm	10
17581	18 mm	10
17582	19 mm	10
17488	20 mm	10

N.p.	specyfikacja	
17489	21 mm	10
17583	22 mm	10
17490	23 mm	10
17584	24 mm	10
17491	25 mm	10
17492	26 mm	10
17585	27 mm	10
17493	28 mm	10
17494	29 mm	10
17586	30 mm	10
17587	32 mm	10
17495	33 mm	10
17496	34 mm	10
17589	36 mm	10

FESTA

KLUCZE PŁASKO – OCZKOWE Z GRZECHOTKĄ

CrV 72T



N.p.	specyfikacja	
17628	8 mm	10
17622	10 mm	10
17623	13 mm	10
17624	14 mm	10
17629	15 mm	10
17630	16 mm	5

N.p.	specyfikacja	
17625	17 mm	10
17631	18 mm	10
17626	19 mm	10
17632	21 mm	5
17633	22 mm	5

FESTA

KLUCZE PŁASKO – OCZKOWE Z GRZECHOTKĄ

CrV 72T



N.p.	specyfikacja	
17660	6 mm	10
17676	7 mm	10
17661	8 mm	10
17662	9 mm	10
17663	10 mm	10
17664	11 mm	10
17665	12 mm	10
17666	13 mm	10
17667	14 mm	10
17668	15 mm	10

N.p.	specyfikacja	
17669	16 mm	10
17670	17 mm	10
17671	18 mm	10
17672	19 mm	10
17674	21 mm	5
17675	22 mm	5
17677	24 mm	5
17678	27 mm	5
17679	30 mm	5
17683	32 mm	5

FESTA

KLUCZE PŁASKIE

DIN 895



N.p.	specyfikacja	
17460	6 x 7 mm	10
17461	8 x 9 mm	10
17462	8 x 10 mm	10
17463	10 x 11 mm	10
17481	10 x 13 mm	10
17464	12 x 13 mm	10
17465	14 x 15 mm	10
17467	13 x 17 mm	10
17482	14 x 17 mm	10
17468	16 x 17 mm	10

N.p.	specyfikacja	
17469	17 x 19 mm	10
17470	18 x 19 mm	10
17483	19 x 22 mm	10
17484	19 x 24 mm	10
17471	20 x 22 mm	10
17472	24 x 27 mm	10
17486	21 x 23 mm	10
17480	28 x 30 mm	10
17473	30 x 32 mm	10
17485	36 x 41 mm	10

FESTA

KLUCZE OCZKOWE WYGIĘTE

CrV DIN 838



N.p.	specyfikacja	
17605	6 x 7 mm	10
17606	8 x 9 mm	10
17607	8 x 10 mm	10
17608	10 x 11 mm	10
17609	12 x 13 mm	10
17611	13 x 16 mm	10
17612	13 x 17 mm	10

N.p.	specyfikacja	
17610	14 x 15 mm	10
17613	16 x 17 mm	10
17614	18 x 19 mm	10
17615	20 x 22 mm	10
17616	24 x 27 mm	10
17617	30 x 32 mm	10

FESTA

KLUCZE PŁASKIE

CrV DIN 3110



N.p.	specyfikacja	
17761	14 x 15 mm	10
17769	20 x 22 mm	10

FESTA

KLUCZE PŁASKO – OCZKOWE

CrV DIN 3113



N.p.	specyfikacja	
17788	14 mm	10
17795	21 mm	10
17806	33 mm	10

N.p.	specyfikacja	
17788	14 mm	10
17795	21 mm	10
17806	33 mm	10

FESTA

KLUCZ Z GRZECHOTKĄ ZESTAW

8-9-10-11-12-13-14-15-16-17-18-19 mm



N.p.	specyfikacja	
17619		1



NEW

FESTA

KLUCZ

Cr-Mo



12-13-14-15 mm

16-17-18-19 mm

N.p.	specyfikacja	
17685	12-13-14-15-16-17-18-19 mm	1



FESTA

KLUCZ NASTAWNY

CrV



KLUCZ NASTAWNY

N.p.	rozsah	dł.ka	
17197	0 - 29 mm	200 mm	1
17198	0 - 33 mm	250 mm	1
17199	0 - 38 mm	300 mm	1

N.p.	rozsah	dł.ka	
17200	0 - 24 mm	200 mm	6
17201	0 - 30 mm	250 mm	6
17202	0 - 34 mm	300 mm	6

FESTA



FESTA

KLUCZE PŁASKIE

CrV

DIN 3110



N.p.	specyfikacja	
17506	6 szt. · 6 x 7, 8 x 9, 10 x 11, 12 x 13, 14 x 15, 16 x 17	1
17508	8 szt. · 6 x 7, 8 x 9, 10 x 11, 12 x 13, 14 x 15, 16 x 17, 18 x 19, 20 x 22	1



FESTA

KLUCZE PŁASKO - OCZKOWE

CrV

DIN 3113



N.p.	specyfikacja	
17526	6 szt. · 10 x 10, 11 x 11, 13 x 13, 14 x 14, 16 x 16, 17 x 17	1
17528	8 szt. · 8 x 8, 10 x 10, 11 x 11, 13 x 13, 14 x 14, 16 x 16, 17 x 17, 19 x 19	1



FESTA

KLUCZE OCZKOWE WYGIĘTE

8x

CrV

DIN 838



N.p.	specyfikacja	
17539	6 x 7, 8 x 9, 10 x 11, 12 x 13, 14 x 15, 16 x 17, 18 x 19, 20 x 22	1



FESTA

KLUCZE PŁASKO – OCZKOWE

CrV

DIN 3113



N.p.	specyfikacja	
17532	12 szt. · 8 x 8, 9 x 9, 10 x 10, 11 x 11, 13 x 13, 14 x 14, 16 x 16, 17 x 17, 18 x 18, 19 x 19, 21 x 21, 22 x 22	10
17533	18 szt. · 6 x 6, 7 x 7, 8 x 8, 9 x 9, 10 x 10, 11 x 11, 12 x 12, 13 x 13, 14 x 14, 15 x 15, 16 x 16, 17 x 17, 18 x 18, 19 x 19, 20 x 20, 21 x 21, 22 x 22, 24 x 24	1
17534	25 szt. · 6 x 6, 7 x 7, 8 x 8, 9 x 9, 10 x 10, 11 x 11, 12 x 12, 13 x 13, 14 x 14, 15 x 15, 16 x 16, 17 x 17, 18 x 18, 19 x 19, 20 x 20, 21 x 21, 22 x 22, 23 x 23, 24 x 24, 25 x 25, 26 x 26, 27 x 27, 28 x 28, 30 x 30, 32 x 32	4

FESTA

KLUCZE PŁASKO – OCZKOWE Z GRZECHOTKĄ

CrV



7x



N.p.	specyfikacja	
17620	8, 10, 12, 13, 14, 17, 19	5

FESTA

KLUCZE PŁASKO – OCZKOWE Z GRZECHOTKĄ

CrV



7x



N.p.	specyfikacja	
17621	10, 12, 13, 14, 15, 17, 19	5

FESTA

KLUCZE PŁASKIE

CrV

DIN 3110

12x



N.p.	specyfikacja	
17512	6 x 7, 8 x 9, 10 x 11, 12 x 13, 14 x 15, 16 x 17, 18 x 19, 20 x 22, 21 x 23, 24 x 27, 25 x 28, 30 x 32	1

FESTA

ZESTAW KLUCZY RURKOWYCH

CrV

7x



N.p.	specyfikacja	
17501	6 x 7, 8 x 9, 10 x 11, 12 x 13, 14 x 15, 16 x 17, 18 x 19	20
17640	paka na trubkové klíče · 135 mm	50

FESTA

KLUCZE PŁASKIE

DIN 895



N.p.	specyfikacja	
17475	8 szt. · 6 x 7, 8 x 9, 10 x 11, 12 x 13, 14 x 15, 16 x 17, 18 x 19, 20 x 22	5
17476	12 szt. · 6 x 7, 8 x 9, 10 x 11, 12 x 13, 14 x 15, 16 x 17, 18 x 19, 20 x 22, 21 x 23, 24 x 27, 28 x 30, 30 x 32	3

FESTA

KLUCZ RURKOWY

CrV

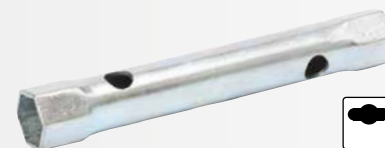

N.p.	specyfikacja		N.p.	specyfikacja	
17650	6 x 7 mm	10	17655	16 x 17 mm	10
17651	8 x 9 mm	10	17645	16 x 18 mm	10
17642	8 x 10 mm	10	17653	16 x 21 mm	10
17652	10 x 11 mm	10	17656	18 x 19 mm	10
17643	12 x 13 mm	10	17657	19 x 22 mm	10
17654	14 x 15 mm	10	17659	22 x 24 mm	10
17644	14 x 17 mm	10	17658	24 x 27 mm	10

KLUCZ DO SZLIFIERKI KATOWEJ, NASTAWNY

N.p.	specyfikacja	
20967	200 mm	15



KLUCZ DO SZLIFIERKI KATOWEJ

N.p.	specyfikacja	
20968	200 mm	1

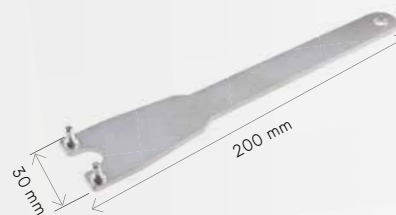

FESTA

KLUCZ DO MONTAŻU RUSZTOWAŃ



N.p.	specyfikacja	
17452	19 x 22 mm	2



FESTA

KLUCZ DO MONTAŻU RUSZTOWAŃ

N.p.	specyfikacja	
17451	18 mm	10
17450	19 mm	10



FESTA

KLUCZ DYNAMOMETRYCZNY

N.p.	specyfikacja	
17203	1/4" 5 - 25 Nm	1
17204	1/2" 19 - 110 Nm	1
17205	1/2" 42 - 210 Nm	1
17206	3/4" 140 - 700 Nm	1



FESTA

made by **HENITON**
NASADKI UDAROWE

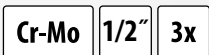

Č.p.	specifikace	
17338	21 mm	5



KLUCZ DO KÓŁ



N.p.	specyfikacja	
17600	17, 19, 22 mm, 13/16"	16

KLUCZ DO KÓŁ



N.p.	specyfikacja	
17601	17, 19, 21 mm	20

TELESKOPOWY KLUCZ DO KÓŁ



N.p.	specyfikacja	
17603	17 x 19 mm, 21 x 23 mm	20

KLUCZ DO ŚWIEC



N.p.	specyfikacja	
17261	16 mm	1
17262	21 mm	1

FESTA

KLUCZ NASTAWNY HAKOWY

CrV



N.p.	specyfikacja		
17680	19 - 51 mm	165 mm	5
17681	32 - 76 mm	216 mm	5
17682	51 - 121 mm	267 mm	5

ŚCIĄGACZ DO ŁOŻYSK



N.p.	max. Ø	głębokość	
23734	Ø 100 mm	50-95 mm	1
23735	Ø 150 mm	100-150 mm	1
23736	Ø 200 mm	110-190 mm	1

ŚCIĄGACZ DO ŁOŻYSK



N.p.	max. Ø	głębokość	
23730	Ø 100 mm	50-95 mm	2
23731	Ø 150 mm	100-150 mm	2
23732	Ø 200 mm	110-190 mm	2

FESTA

KLUCZ DO ZAWORÓW GRZEJNIKOWYCH

CrV 1/2"

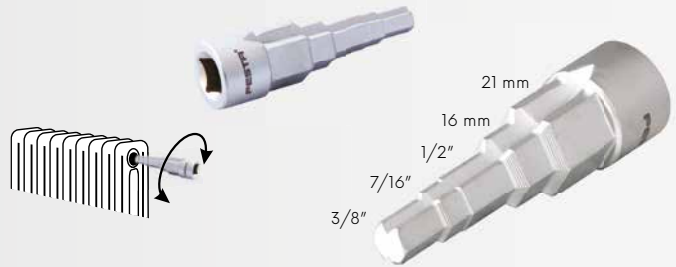

N.p.	specyfikacja	
17455	pro rączni 1/2"	10



KLUCZ DO ODPOWIEZRZANIA GRZEJNIKÓW

2x



N.p.	specyfikacja	
17454	5 x 5 mm	1

KLUCZ DO ODPOWIEZRZANIA GRZEJNIKÓW ZE ZBIORNICZKIEM



N.p.	specyfikacja	
17459	50 ml	1

FESTA

UNIWERSALNY KLUCZ DO SZAFKI ROZDZIELCZEJ

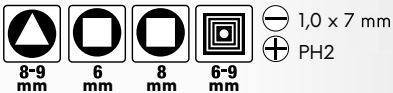

N.p.	specyfikacja	
17458		1

FESTA

UNIWERSALNY KLUCZ DO SZAFKI ROZDZIELCZEJ

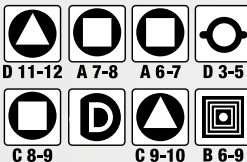

N.p.	specyfikacja	
17456		50



ERGONOMIC handle

STANDARD +30% FESTA

CrV · krom-vanadij celik

HRC 58-62 · twardosc szozek

ERGONOMIC HANDLE · ergonomiczne uchwyty wykonane z wysokiej jakosci gumy TPE

· hartowane indukcyjnie



SZCZYPCE UNIWERSALNE

DIN 5746	TUV GS	N.p.	specyfikacja	
CrV	HRC 58-62	17101	160 mm	6
		17102	180 mm	6
		17103	200 mm	6



SZCZYPCE BOCZNE

DIN 5749	TUV GS	CrV	HRC 58-62	ERGONOMIC HANDLE	N.p.	specyfikacja	
					17148	180 mm	6



SZCZYPCE BOCZNE

DIN 5749	TUV GS	CrV	HRC 58-62	ERGONOMIC HANDLE	N.p.	specyfikacja	
					17104	160 mm	6
					17105	180 mm	6



SZCZYPCE WYDŁUŻONE

DIN 5745	TUV GS	CrV	HRC 58-62	ERGONOMIC HANDLE	N.p.	specyfikacja	
					17140	160 mm	6
					17142	200 mm	6



SZCZYPCE WYDŁUŻONE ZAGIĘTE

DIN 5749	TUV GS	CrV	HRC 58-62	ERGONOMIC HANDLE	N.p.	specyfikacja	
					17145	160 mm	6
					17146	200 mm	6



FESTA





FESTA

SZCZYPCE UNIWERSALNE

DIN 5746		HRC 58-64		
N.p.	specyfikacja			
17001	160 mm	6		
17002	180 mm	6		
17003	200 mm	6		



FESTA

SZCZYPCE BOCZNE

DIN 5749		HRC 58-64		
N.p.	specyfikacja			
17004	160 mm	6		
17005	180 mm	6		



FESTA

SZCZYPCE BOCZNE

DIN 5749		HRC 58-64		
N.p.	specyfikacja			
17108	180 mm	6		



FESTA

OBCEGI

DIN 5748		HRC 58-64		
N.p.	specyfikacja			
17110	160 mm	6		



FESTA

SZCZYPCE WYDŁUŻONE

DIN 5745		HRC 58-64		
N.p.	specyfikacja			
17006	160 mm	6		
17011	200 mm	6		



FESTA

SZCZYPCE WYDŁUŻONE ZAGIĘTE

DIN 5745		HRC 58-64		
N.p.	specyfikacja			
17007	160 mm	6		
17008	200 mm	6		



FESTA

SZCZYPCE PŁASKIE

DIN 5746		HRC 50-55		
N.p.	specyfikacja			
17009	160 mm	6		



FESTA

SZCZYPCE OKRĄGŁE

DIN 5745			
N.p.	specyfikacja		
17010	160 mm	6	



FESTA

SZCZYPCE DO IZOLACJI

DIN 5744			
N.p.	specyfikacja		
17024	160 mm	6	



SZCZYPCE UNIWERSALNE

DIN 5746		
N.p.	specyfikacja	
17094	160 mm	6
17095	180 mm	6
17096	200 mm	6



SZCZYPCE BOCZNE

DIN 5749		
N.p.	specyfikacja	
17097	160 mm	6
17098	180 mm	6



SZCZYPCE WYDŁUŻONE

DIN 5745		
N.p.	specyfikacja	
17099	160 mm	6
17100	200 mm	6



SZCZYPCE VDE UNIWERSALNE

1000 V IEC/EN60900:2004

DIN 5746 CrV HRC 58-62



N.p.	specyfikacja	
17125	160 mm	6
17126	180 mm	6
17127	200 mm	6



SZCZYPCE VDE BOCZNE

1000 V IEC/EN60900:2004

DIN 5749 CrV HRC 58-62



N.p.	specyfikacja	
17128	160 mm	6



SZCZYPCE VDE DO KABLI

1000 V IEC/EN60900:2004

CrV HRC 58-62



N.p.	specyfikacja	
17130	160 mm	6



SZCZYPCE VDE PÓŁOKRĄGŁE

1000 V IEC/EN60900:2004

DIN 5745 CrV HRC 58-62



N.p.	specyfikacja	
17133	160 mm	6



SZCZYPCE VDE PÓŁOKRĄGŁE ODGIĘTE

1000 V IEC/EN60900:2004

DIN 5745 CrV HRC 58-62



N.p.	specyfikacja	
17135	160 mm	6



SZCZYPCE VDE OKRĄGŁE

1000 V IEC/EN60900:2004

DIN 5745 CrV HRC 58-62



N.p.	specyfikacja	
17137	160 mm	6



SZCZYPCE VDE DO IZOLACJI

1000 V IEC/EN60900:2004

CrV DIN 5744



N.p.	specyfikacja	
17138	160 mm	6



SZCZYPCE DO CIENKICH KABLI
max Ø 0,2 - 2,1 mm

CrV	N.p.	specyfikacja	
	17047	140 mm	10



SZCZYPCE DO CIENKICH KABLI
0,75; 1,0; 1,5; 2,5; 4,0; 6,0mm²

CrV	N.p.	specyfikacja	
	17087	145 mm	1



AUTOMATYCZNY ŚCIĄGACZ IZOLACJI

0,5 - 6 mm²
190 mm



N.p.	specyfikacja	
17178		1



AUTOMATYCZNY ŚCIĄGACZ IZOLACJI

N.p.	specyfikacja	
17180	Ø 0,75 - 2,5 mm	12



SZCZYPCE DO ŚCIĄGANIA IZOLACJI

N.p.	specyfikacja	
17181	Ø 0,60 - 2,6 mm	10

NEW



FESTA

ŚCIAĞACZ IZOLACJI

· Ø 0,2-4 mm

N.p. 16205 Specyfikacja 125 mm 1



FESTA

ŚCIAĞACZ IZOLACJI

AWG	mm ²
10	6,0
12	4,0
14	2,5
16	1,5
18	1,0
20	0,5

· Kabel koncentryczny RG6/59
· przewód niskonapięciowy R 8 - 13 mm

N.p. 16202 Specyfikacja 125 mm 10



FESTA
INDUSTRY

SZCZYPCE ZACISKOWE DO KOŃCÓWEK KABLOWYCH

6x

N.p. 18445 Specyfikacja 1

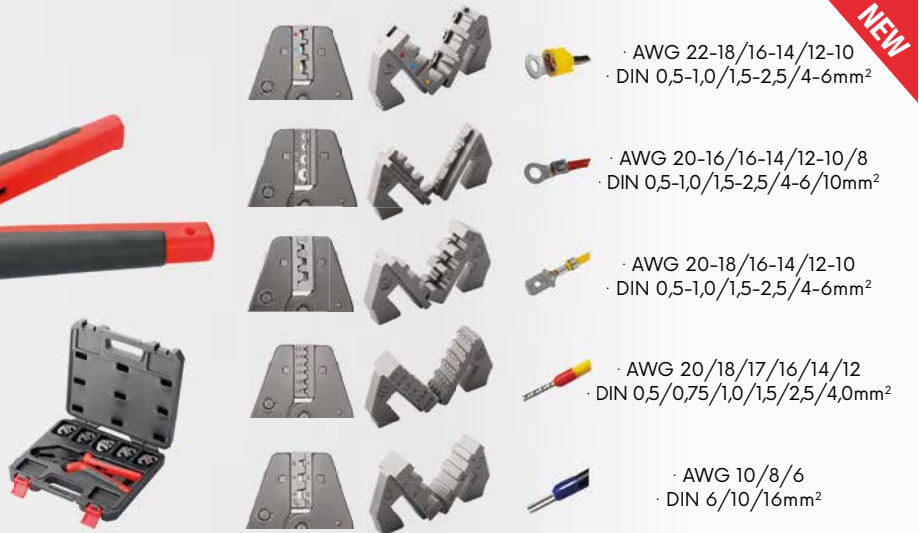

NEW



FESTA
INDUSTRY

SZCZYPCE DO ZACISKANIA KOŃCÓWEK

N.p. 16206 Specyfikacja 1



- AWG 10-22
· 0,5-0,6mm²
- AWG 10-22
· 0,5-0,6mm²
- AWG 10-22
· 0,5-0,6mm²
- ściągania izolacji
· AWG 10-24
· 0,2-0,6mm²

NEW



FESTA
INDUSTRY

SZCZYPCE DO ZACISKANIA KOŃCÓWEK

N.p. 16208 Specyfikacja 1



- 1,5; 2,5; 6,0mm²
- 1,5; 2,5; 6,0mm²
- ściągania izolacji · 0,75; 1,0; 1,5; 2,5; 4,0; 6,0mm²
- cięcie śrub · M2,6; M3; M3,5; M4; M5

NEW



FESTA

SZCZYPCE WIELOFUNKCYJNE

9 funkcji futerał

CrV

N.p.	specyfikacja	
16232		12



FESTA

ZESTAW MINI SZCZYPIEC

4x

N.p.	specyfikacja	
17040		6



FESTA

MINI SZCZYPCE UNIWERSALNE

N.p.	specyfikacja	
17041	110 mm	12



FESTA

MINI SZCZYPCE BOCZNE

N.p.	specyfikacja	
17042	110 mm	12



FESTA

MINI SZCZYPCE CZOŁOWE

N.p.	specyfikacja	
17043	100 mm	12



FESTA

MINI SZCZYPCE WYDŁUŻONE

N.p.	specyfikacja	
17044	120 mm	12



FESTA

MINI SZCZYPCE OKRĄGŁE

N.p.	specyfikacja	
17045	120 mm	12



SZCZYPCE SEGERA

N.p.	specyfikacja	
17025	zestaw	10



FESTA

SZCZYPCE SEGER

N.p.	specyfikacja	
17190	180 mm wew	6
17191	180 mm zewnetrz	6

FESTA

SZCZYPCE SEGER

N.p.	specyfikacja	
17192	180 mm wew	15
17193	180 mm zewnetrz	15

FESTA

SZCZYPCE WIŁOFUNKCYJNE

do ogrodzenia

CrV



N.p.	specyfikacja
17109	270 mm



SZCZYPCE ZACISK. MORSE'A

Ć.p.	Specyfikacja		
17150	220 mm	1	



SZCZYPCE ZACISK. MORSE'A

Ć.p.	Specyfikacja		
17151	225 mm	1	



SZCZYPCE ZACISK. MORSE'A

Ć.p.	specyfikacja		
17034	220 mm	5	



FESTA

SZCZYPCE ZACISK. MORSE'A

Ć.p.	specyfikacja		
17036	270 mm	5	



SZCZYPCE ZACISK. MORSE'A

Ć.p.	specyfikacja		
17035	220 mm	10	



FESTA

SZCZYPCE ZACISK. MORSE'A

Ć.p.	specyfikacja		
17023	220 mm	6	

FESTA

KLUCZ DO RUR 45°, S

CrV



N.p.	specyfikacja	
17067	1" 330 mm	1
17068	1,5" 420 mm	1
17069	2" 540 mm	1



FESTA

KLUCZ DO RUR

CrV

N.p.	specyfikacja	
17063	230 mm	6
17064	300 mm	6



FESTA

KLUCZ DO RUR 90°

CrV



N.p.	specyfikacja	
17075	1" 330 mm	1
17076	1,5" 420 mm	1
17077	2" 540 mm	1



FESTA

KLUCZ DO RUR 90°

CrV



N.p.	specyfikacja	
17070	2,5" 355 mm	12
17071	3" 455 mm	8
17072	3,5" 610 mm	10



KLUCZ DO RUR Z NAKRĘTKĄ

N.p.	specyfikacja	
17065	260 mm	36
17066	300 mm	36

FESTA

SZCZYPCE HYDRAULICZNE



CrV

N.p.	specyfikacja	zakres szczęk	☑
16500	180 mm	0 - 40 mm	1
16501	250 mm	0 - 52 mm	1
16502	300 mm	0 - 68 mm	1

FESTA

SZCZYPCE HYDRAULICZNE



CrV

N.p.	specyfikacja	zakres szczęk	☑
17059	180 mm	0 - 30 mm	6
17061	250 mm	0 - 30 mm	6
17062	300 mm	0 - 40 mm	6
17080	400 mm	0 - 84 mm	4

FESTA

SZCZYPCE HYDRAULICZNE



CrV

N.p.	specyfikacja	zakres szczęk	☑
17084	250 mm	0 - 30 mm	6

FESTA

SZCZYPCE HYDRAULICZNE



CrV

· large range of jaws

N.p.	specyfikacja	zakres szczęk	☑
17086	250 mm	0 - 50 mm	6

FESTA

SZCZYPCE HYDRAULICZNE



CrV

N.p.	specyfikacja	zakres szczęk	☑
17081	180 mm	0 - 30 mm	6
17014	250 mm	0 - 30 mm	6
17082	300 mm	0 - 50 mm	6

FESTA

SZCZYPCE HYDRAULICZNE



CrV

N.p.	specyfikacja	zakres szczęk	☑
17079	250 mm	0 - 50 mm	6

FESTA

SZCZYPCE HYDRAULICZNE



CrV

N.p.	specyfikacja	zakres szczęk	☑
17012	250 mm	0 - 40 mm	6
17060	300 mm	0 - 50 mm	10

FESTA

SZCZYPCE HYDRAULICZNE



CrV

N.p.	specyfikacja	zakres szczęk	☑
17013	250 mm	0 - 30 mm	6
17033	300 mm	0 - 50 mm	6

PLASTIKOWE OCHRONNIKI DO SZYPIEC

· dla 17061, 17079



N.p.	specyfikacja	☑
17085	1 pair	1

FESTA

NOŻYCE DO LIN

- Stalowe druty
- Kable ACSR
- Kable samolotowe

CrV

max. Ø 6 mm

Č.p.	specifikace	☑
17029	200 mm	6

FESTA

NOŻYCE DO LIN

- Stalowe druty
- Kable ACSR
- Kable samolotowe

CrV

max. Ø 12 mm

Č.p.	specifikace	☑
17039	24' 610 mm	8



FESTA

NOŻYCE DO PRĘTÓW I LIN

Cr-Mo



N.p.	specyfikacja		
17049	18' 450 mm	max. 6 mm < 40 HRC	1

FESTA

NOŻYCE DO PRĘTÓW

Cr-Mo

HRC 58-62



N.p.	specyfikacja	max. Ø drutu	
17051	14' 350 mm	max. 5 mm < 45 HRC	1
17052	18' 450 mm	max. 6 mm < 45 HRC	1
17053	24' 610 mm	max. 8 mm < 45 HRC	1
17054	30' 760 mm	max. 10 mm < 45 HRC	1
17048	36' 900 mm	max. 12 mm < 45 HRC	1



FESTA

NOŻYCE DO PRĘTÓW I LIN

· lub kable i przewody

Cr-Mo

HRC 58-62



N.p.	specyfikacja	max. Ø drutu	max. Ø lanka	max. Ø kabelu	
17055	14' 360 mm	max. 5 mm < 45 HRC	max. 3,5 mm	max. 8 mm	1
17056	18' 460 mm	max. 6 mm < 45 HRC	max. 5 mm	max. 10 mm	1
17057	24' 610 mm	max. 8 mm < 45 HRC	max. 7 mm	max. 12 mm	1
17058	30' 760 mm	max. 10 mm < 45 HRC	max. 9 mm	max. 14 mm	1
17046	35' 900 mm	max. 12 mm < 45 HRC	max. 10 mm	max. 16 mm	1



FESTA

NOŻYCE DO PRĘTÓW

Cr-Mo

HRC 57-62

max. Ø
4 mm



N.p.	specyfikacja		
17038	8' 210 mm	max. 4 mm < 30 HRC	10



FESTA

NOŻYCE DO PRĘTÓW

- miękki drut: R 6 mm
- drut średnio twardy: Ø 5 mm
- drut twardy: R 4 mm

CrV



N.p.	Specyfikacja	
17078	200 mm	12



NOŻYCE DO PRĘTÓW



N.p.	specyfikacja	max. Ø drutu	
17028	14' 350 mm	max. 5 mm < 30 HRC	30
17020	18' 450 mm	max. 6 mm < 30 HRC	6
17021	24' 610 mm	max. 8 mm < 30 HRC	10
17022	30' 760 mm	max. 10 mm < 30 HRC	5

NEW



FESTA

SZCZYPCE TYNKARSKIE

CrV HRC 58-62

N.p.	specyfikacja	
17172	200 mm	1



FESTA

SZCZYPCE TYNKARSKIE

CrV

N.p.	specyfikacja	
17300	160 mm	1
17301	180 mm	10
17302	200 mm	6
17303	250 mm	1



FESTA

SZCZYPCE TYNKARSKIE

CrV

N.p.	specyfikacja	
17305	220 mm	5
17306	250 mm	1
17304	275 mm	6



SZCZYPCE TYNKARSKIE

N.p.	specyfikacja	
17015	160 mm	6
17016	180 mm	6
17017	200 mm	6



SZCZYPCE TYNKARSKIE

N.p.	specyfikacja	
17019	220 mm	6
17083	275 mm	6



FESTA

SZCZYPCE BLACHARSKIE PROSTE

N.p.	specyfikacja	
17089	150 x 215 mm	2

NEW



FESTA

SZCZYPCE BLACHARSKIE PROSTE

N.p.	specyfikacja	
17341	24 x 180 mm	1

NEW



FESTA

SZCZYPCE BLACHARSKIE WYGETĘ 45°

N.p.	specyfikacja	
17342	24 x 180 mm	1



FESTA

SZCZYPCE BLACHARSKIE PROSTE

N.p.	specyfikacja	
17093	95 x 270 mm	6



FESTA

SZCZYPCE BLACHARSKIE WYGETĘ 45°

N.p.	specyfikacja	
17091	50 x 280 mm	10



FESTA

SZCZYPCE BLACHARSKIE WYGETĘ 90°

N.p.	specyfikacja	
17092	50 x 260 mm	10



FESTA

SZCZYPCE BLACHARSKIE PROSTE

N.p.	specyfikacja	
17090	50 x 280 mm	10

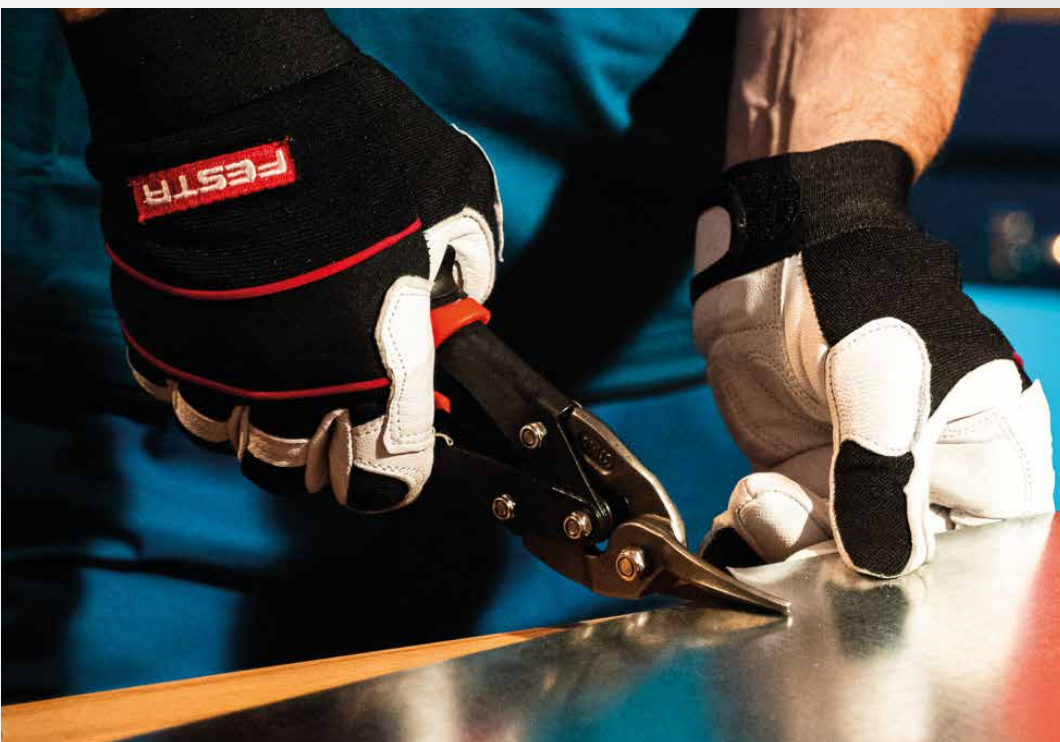

FESTA

NOŻYCE DO BLACHY

CrV		
N.p.	specyfikacja	
17170	50 250 mm	6



NOŻYCE DO BLACHY

CrV		
N.p.	specyfikacja	
17167	70 300 mm	5



NOŻYCE DO BLACHY

CrV		
N.p.	specyfikacja	
17165	60 250 mm	5



NOŻYCE DO BLACHY

CrV		
N.p.	specyfikacja	
17169	35 250 mm	5

FESTA

NOŻYCE DO BLACHY
DŁUGI



Cr-Mo HRC 58-62

N.p.	specyfikacja	
17113	proste 80 300 mm	6



FESTA

NOŻYCE DO BLACHY

Cr-Mo HRC 58-62

N.p.	specyfikacja	
17111	proste 40 250 mm	6
17116	prawe 40 250 mm	6
17121	lewe 40 250 mm	6



FESTA

NOŻYCE DO BLACHY

Cr-Mo HRC 58-62

N.p.	specyfikacja	
17112	rovné 40 260 mm	6
17117	pravé 40 260 mm	6
17122	levé 40 260 mm	6





PRZYSTAWKA DO WIERTARKI DO CIĘCIA BLACHY

Steel	Cu	ALU	
0.8-1mm	1.5mm	1.5mm	
N.p. specyfikacja			
20364			1



NOŻYCE DO BLACHY

max 0,8 mm

N.p. specyfikacja			
17186			265 mm
			6

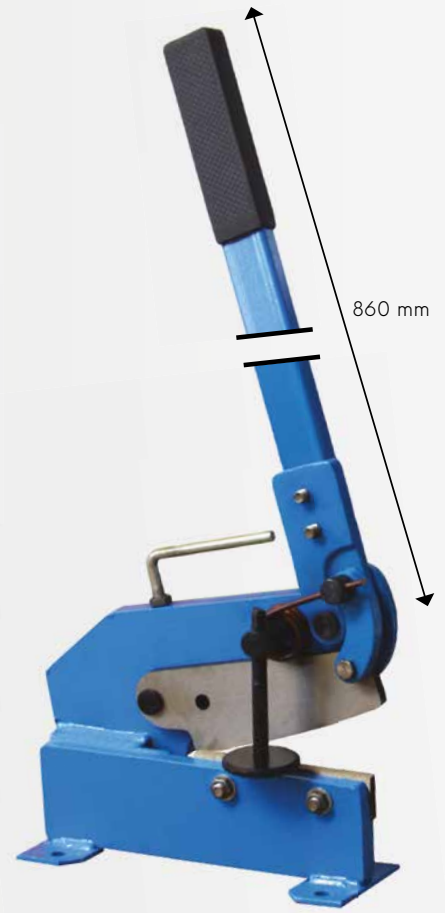

GILOTYNA DO STALI

	17175	17177
	max. 4mm	5mm
	max. \varnothing 10mm	\varnothing 12mm
	max. 8x8mm	10x10mm

N.p. specyfikacja			
17175			150 mm
17177			250 mm
			1
			1

PRZYSTAWKA DO WIERTARKI DO CIĘCIA BLACHY

Max. grubość blachy:

- 1,8 mm - stal
- 1,2 mm - inox
- 2 mm - tworzywo, ALU, miedz



N.p. specyfikacja			
20363			5



NOŻYCE

INOX



Č.p.	specifikace	
16420	60 200 mm	12



NOŻYCE

INOX



Č.p.	specifikace	
17159	65 220 mm	12



NOŻYCE

INOX



Č.p.	specifikace	
17158	50 150 mm	10



NOŻYCE

INOX



Č.p.	specifikace	
17160	70 210 mm	12



NOŻYCE

INOX

Č.p.	specifikace	
16405	14 cm	24
16406	17 cm	24
16407	19 cm	24
16408	21,5 cm	12



NOŻYCE

3x INOX

Č.p.	specifikace	
16401	3 ks	48



FESTA

DZIURKACZ REWOLWEROWY



N.p.	specyfikacja	
17185	Ø 2; 2,5; 3; 3,5; 4; 4,5 mm	12



FESTA

SZCZYPCE DO LISTEW PCV Z OSTRZAMI

zastosowanie do: cokołów, profili, rur



N.p.	specyfikacja	
17050	60 250 mm ø 17 mm, ø 20 mm, ø 27 mm	8



SZCZYPCE DO ŁĄCZENIA



N.p.	specyfikacja	
17187	350 mm	6



SZCZYPCE DO ŁĄCZENIA



N.p.	specyfikacja	
17188	250 mm	12



SZCZYPCE DO KOTEW MOLLY



N.p.	specyfikacja	
17189	255 mm	12





FESTO

FESTO

NITOWNICA OBROTOWA

Cr-Mo

- Ø 2,4 mm
- Ø 3,2 mm
- Ø 4,0 mm
- Ø 4,8 mm



N.p. specyfikacja
24007 200 mm



1



FESTO

NITOWNICA OBROTOWA

Cr-Mo

- Ø 2,4 mm
- Ø 3,2 mm
- Ø 4,0 mm
- Ø 4,8 mm



N.p. specyfikacja
24010 250 mm



12



FESTO

NITOWNICA OBROTOWA

Cr-Mo

- Ø 2,4 mm
- Ø 3,2 mm
- Ø 4,0 mm
- Ø 4,8 mm
- Ø 6,4 mm



N.p. specyfikacja
24017 280 mm



1



FESTO

NITOWNICA OBROTOWA

Cr-Mo

- Ø 2,4 mm
- Ø 3,2 mm
- Ø 4,0 mm
- Ø 4,8 mm
- Ø 6,4 mm



N.p. specyfikacja
24015 530 mm



1



FESTO

NITOWNICA OBROTOWA

Cr-Mo

- Ø 2,4 mm
- Ø 3,2 mm
- Ø 4,0 mm
- Ø 4,8 mm



N.p. specyfikacja
24030 255 mm



24



FESTO

NITOWNICA OBROTOWA

Cr-Mo

N.p. specyfikacja
24020 290 mm



8





NITOWNICA OBROTOWA



Cr-Mo



Ø 2,4 x 6 mm
Ø 3,2 x 6 mm
Ø 4,0 x 6 mm
Ø 4,8 x 6 mm



N.p. specyfikacja
24005 260 mm

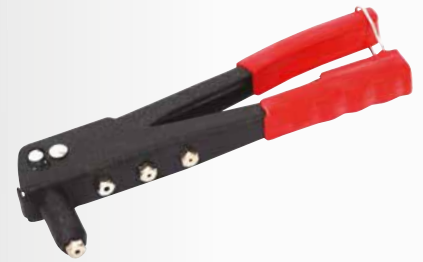

NITOWNICA OBROTOWA



N.p. specyfikacja
24000 240 mm

FESTA

NITOWNICA DO WIERTARKI



Ø 2,4 mm
Ø 3,2 mm
Ø 4,0 mm
Ø 4,8 mm



Cr-Mo



N.p. specyfikacja
24008

1

NITY ALU

ALU

50x



N.p.	specyfikacja	
23970	3,2 x 6 mm	25
23971	3,2 x 8 mm	25
23972	3,2 x 10 mm	25
23973	3,2 x 12 mm	25
23974	3,2 x 14 mm	25
23975	4,0 x 6 mm	25
23976	4,0 x 8 mm	25
23977	4,0 x 10 mm	25
23978	4,0 x 12 mm	25
23979	4,0 x 14 mm	25
23985	4,8 x 6 mm	25
23986	4,8 x 8 mm	25
23987	4,8 x 10 mm	25
23988	4,8 x 12 mm	25
23989	4,8 x 14 mm	25



FESTA

NITOWNICA DO NAKRĘTEK NITUJĄCYCH

Cr-Mo

- M3
- M4
- M5
- M6
- M8
- M10



N.p. specyfikacja
24036 330 mm



1

FESTA

KOŃCÓWKI DO NITONAKRĘTEK

· dla 24035, 24036

Cr-Mo



N.p.	specyfikacja	
24038	M3	1
24039	M4	1
24040	M5	1
24041	M6	1
24042	M8	1
24043	M10	1



FESTA

NITOWNICA DO NAKRĘTEK NITUJĄCYCH

Cr-Mo

- M3
- M4
- M5
- M6



N.p. specyfikacja
24035 200 mm



1

NITONAKRĘTKI,

ALU

20x







N.p.	specyfikacja	
23950	M3 x 9 mm	20
23951	M4 x 11 mm	20
23952	M5 x 12 mm	50
23953	M6 x 14 mm	50
23954	M8 x 16,5 mm	25
23955	M10 x 18 mm	20



FESTA

ZSZYWACZ

-  | 6 - 14 mm
23960 - 23964
23760 - 23764,
23906 - 23914
-  | 10 - 14 mm
23965
-  | 15 mm
23966
-  | 15 mm
23967







N.p. specyfikacja
23927

6

FESTA

ZSZYWACZ

-  | 6 - 14 mm
23960 - 23964
-  | 12 mm
23965
-  | 14 mm
23966
-  | 14 mm
23967





N.p. specyfikacja
23924

12

FESTA

ZSZYWACZ

-  | 6 - 14 mm
23960 - 23964
-  | 14 mm
23966
-  | 14 mm
23967



N.p. specyfikacja
23923

12



FESTA

ZSZYWACZ

-  **53** | 4 - 14 mm
23904 - 23914,
23760 - 23765

N.p. specyfikacja
23925 4 - 14 mmlock

20



ZSZYWACZ

-  **53** | 4 - 14 mm
23760 - 23765,
23904 - 23914

N.p. specyfikacja
23800

20



ZSZYWACZ



-  | 0,7 mm
 $\alpha=9-11\text{ mm}, b=5,5\text{ mm}, c=6,4\text{ mm}$

N.p. specyfikacja
23920

4



FESTA

MŁOTEK ZSZYWAJĄCY

-  | 6 - 10 mm
23960 - 23962

N.p. specyfikacja
23922

10



MŁOTEK ZSZYWAJĄCY

-  | 6 - 10 mm
23960 - 23962

N.p. specyfikacja
23928

6



FESTA

DO USUWANIA ZSZYWEK

N.p. specyfikacja
23945

25

FESTA

ZSZYWKI EXTRA



N.p.	specyfikacja	
23960	b=6 mm, 1000 szt.	50
23961	b=8 mm, 1000 szt.	50
23962	b=10 mm, 1000 szt.	50
23963	b=12 mm, 1000 szt.	50
23964	b=14 mm, 1000 szt.	50

FESTA

ZSZYWKI

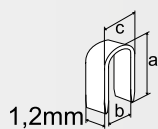

N.p.	specyfikacja	
23965	a=12 mm, b=6,5 mm, c=7,5 mm, 1000 TW	50

ZSZYWKI (TYP 53)

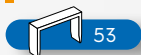

N.p.	specyfikacja	
23904	b=4 mm 1000 szt.	200
23906	b=6 mm 1000 szt.	200
23908	b=8 mm 1000 szt.	200
23910	b=10 mm 1000 szt.	200
23912	b=12 mm 1000 szt.	200
23914	b=14 mm 1000 szt.	200

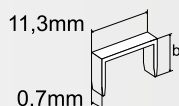

FESTA

ZSZYWKI



N.p.	specyfikacja	
23966	14 mm 1000 TW	100

FESTA

ZSZYWKI



N.p.	specyfikacja	
23967	14 mm 1000 TW	100

ZSZYWKI (TYP 53)



N.p.	specyfikacja	
23760	b=4 mm 2000 szt.	10
23761	b=6 mm 2000 szt.	10
23762	b=8 mm 2000 szt.	10
23763	b=10 mm 2000 szt.	10
23764	b=12 mm 2000 szt.	10

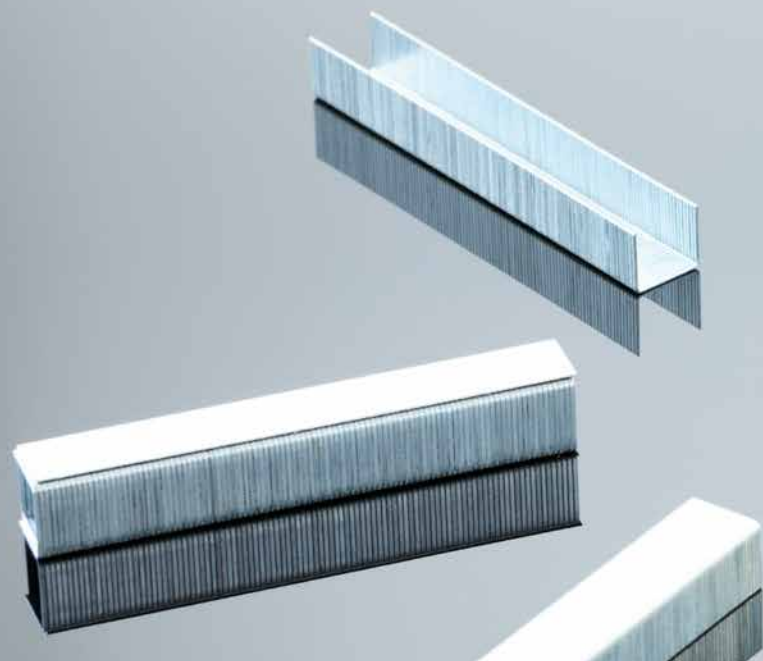
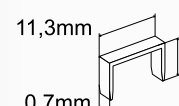

FESTA



FESTA

SZCZOTKA STALOWA



N.p.	specyfikacja	kwestia	
22080	270 mm	5 kwestia	12

FESTA

SZCZOTKA MOSIĘŻNA



N.p.	specyfikacja	kwestia	
22082	270 mm	5 kwestia	12

FESTA

ZESTAW SZCZOTEK



nylon, stal, mosiądz

N.p.	specyfikacja	
22086	180 mm	12

ZESTAW SZCZOTEK



N.p.	kwestia	
22081	3 kwestia	12



22158



22159

PĘDZEL DRUCIANY

N.p.	specyfikacja	dрут	
22158	200 mm	stal	1
22159	200 mm	mosiądz	1



22035



22036

SZCZOTKA STALOWA

N.p.	specyfikacja	dрут	
22035	270 mm	stal	24
22036	270 mm	Stal nierdzewna	24



SZCZOTKA STALOWA

N.p.	specyfikacja	kwestia	
22033	300 mm	4 kwestia	12
22034	300 mm	5 kwestia	12



SZCZOTKA

N.p.	kwestia	
22078	3 kwestia	20



SZCZOTKA

N.p.	specyfikacja	kwestia	
22079	300 mm	4 kwestia	6

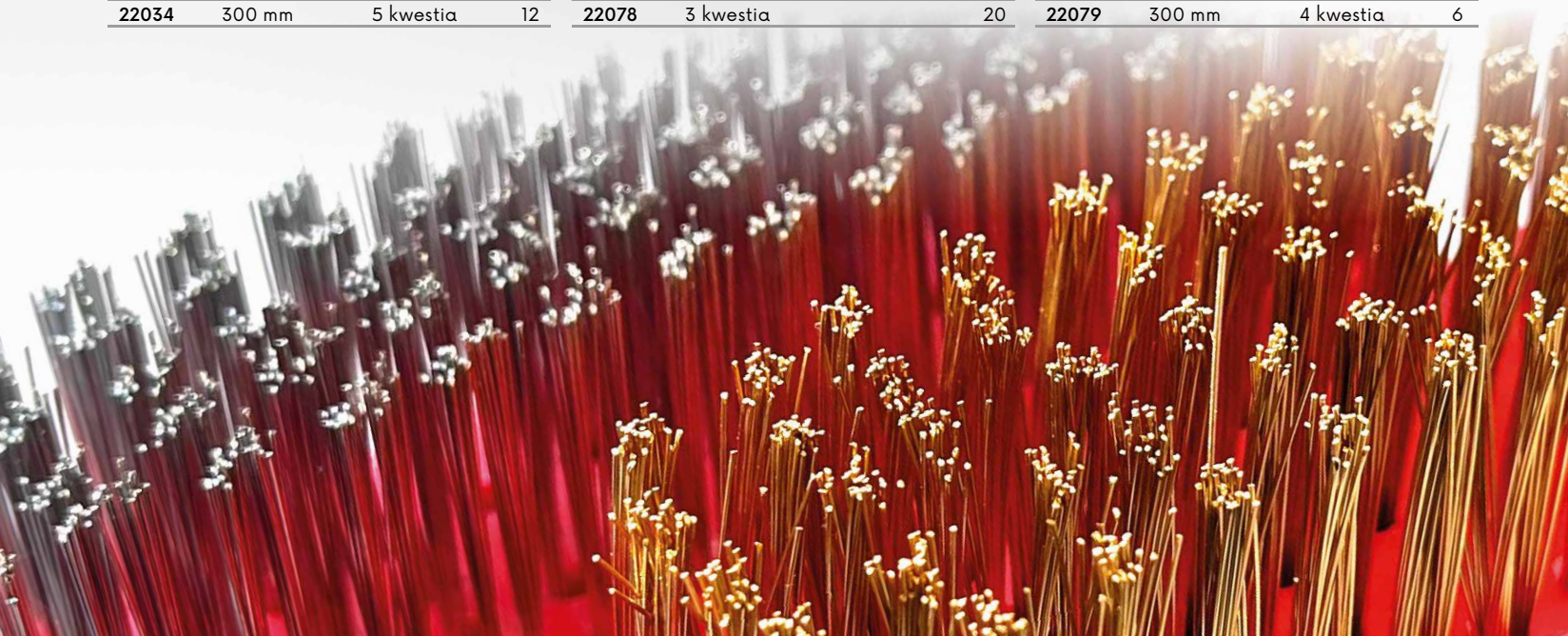

FESTA



FESTA
PILNIK PŁASKI



N.p.	specyfikacja	chropowość	
22206	150 mm	2	10
22180	250 mm	2	10



FESTA
PILNIK PÓŁOKRĄGŁY



N.p.	specyfikacja	chropowość	
22207	150 mm	2	10
22182	250 mm	2	10



FESTA
PILNIK KWADRATOWY



N.p.	specyfikacja	chropowość	
22184	250 mm	2	10



FESTA
PILNIK TRÓJKĄTNY



N.p.	specyfikacja	chropowość	
22183	250 mm	2	10



FESTA
PILNIK OKRĄGŁY



N.p.	specyfikacja	chropowość	
22181	250 mm	2	10



FESTA
PILNIK TRÓJKĄTNY DO BRZESZCZOTÓW



N.p.	specyfikacja	chropowość	
22178	150 mm	1	10

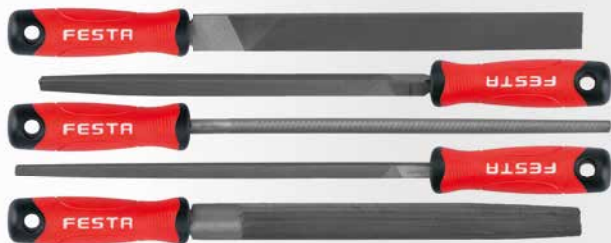

FESTA
ZESTAW PILNIKÓW



N.p.	specyfikacja	chropowość	
22209	150 mm	2	10
22186	250 mm	2	5



FESTA
ZESTAW PILNIKÓW



N.p.	specyfikacja	chropowość	
22208	150 mm	2	10
22185	250 mm	2	5



FESTA

PILNIK DO PIŁY ŁAŃCUCHOWEJ



N.p.	specyfikacja		N.p.	specyfikacja	
22170	200 mm 3,5 mm	10	22173	200 mm 5 mm	10
22171	200 mm 4 mm	10	22174	200 mm 5,5 mm	10
22172	200 mm 4,5 mm	10			

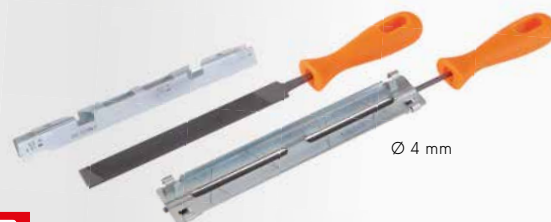

FESTA

ZESTAW NA OSTRENIENIE ŁAŃCUCHÓW



N.p.	specyfikacja	
22190	300 mm	5



FESTA

PILNIKI IGŁOWE



10x	N.p.	specyfikacja	
	22188		20



FESTA

PILNIKI DIAMENTOWE



10x	N.p.	specyfikacja	
	22189		25



FESTA

PILNIK PŁASKI



N.p.	specyfikacja	
22202	150 mm	10
22197	300 mm	10



FESTA

ZESTAW PILNIKÓW



3x	N.p.	specyfikacja	
	22196	250 mm	5



FESTA

PILNIK PÓŁOKRĄGŁY



N.p.	specyfikacja	
22203	150 mm	6
22199	300 mm	6



FESTA

PILNIK OKRĄGŁY



N.p.	specyfikacja	
22204	150 mm	10
22205	250 mm	10
22198	300 mm	10



FESTA

PIŁA DO METALU



FESTA

PIŁA DO METALU

wzmocniona rama



PIŁA DO METALU

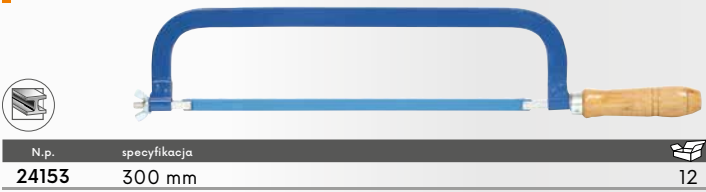

FESTA

PIŁA DO METALU



OPRAWKA DO METALU

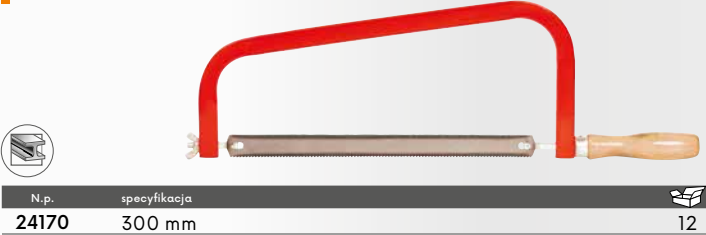

FESTA

PIŁA DO METALU



FESTA

PIŁA DO METALU

brzeszczot 24108



FESTA

PIŁA DO METALU

brzeszczot 24109



PIŁA

N.p.	specyfikacja	
24121	piła	12
24110	brzeszczot	30



PIŁA

5x brzeszczot

N.p.	specyfikacja	
24122	piła	20
24111	brzeszczot	30

FESTA

PIŁA PŁATNICA

TEFLON · 3 x szlifowane, hartowane zęby

N.p.	specyfikacja	
24143	300 mm	12
24144	400 mm	12
24145	500 mm	12



FESTA

PIŁA GRZBIETNICA

TEFLON · 3 x szlifowane, hartowane zęby

N.p.	specyfikacja	
24147	300 mm	6



FESTA

PIŁA RĘCZNA

· 3 x szlifowane, hartowane zęby

N.p.	specyfikacja	
24149	300 mm	12



FESTA

JAPŃSKA PIŁA

SK5 · 3 x szlifowane, hartowane zęby

N.p.	specyfikacja	
24134	250 mm 0,5 mm	10



FESTA

JAPŃSKA PIŁA

SK5 · 3 x szlifowane, hartowane zęby

N.p.	specyfikacja	
24115	260 mm 0,6 mm	10



FESTA

JAPŃSKA PIŁA

SK5 · 3 x szlifowane, hartowane zęby

N.p.	specyfikacja	
24114	260 mm 0,6 mm	10

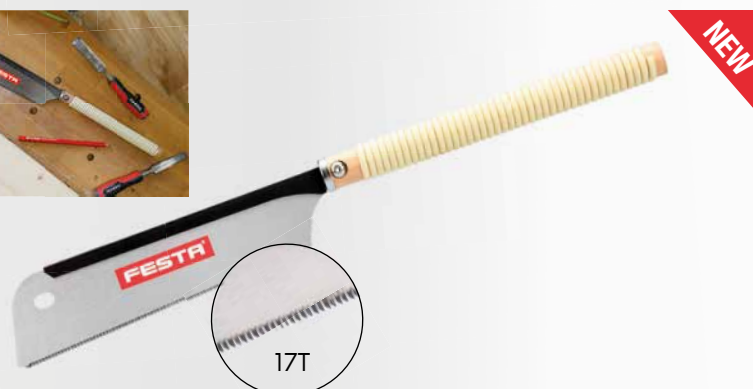



PIŁA DO CIĘCIA POD KĄTEM



N.p.	specyfikacja	
24130	600 mm	1
24131	600 mm, brzeszczot	1



SKRZYŃKA UKOŚNA + PIŁA



N.p.	specyfikacja	
24148	300 mm	25

SKRZYŃKA UKOŚNA



· buk
MADE IN EU

N.p.	specyfikacja	
24171	80 x 300 mm	10

SKRZYŃKA UKOŚNA



N.p.	specyfikacja	
24133	300 x 140 mm	18

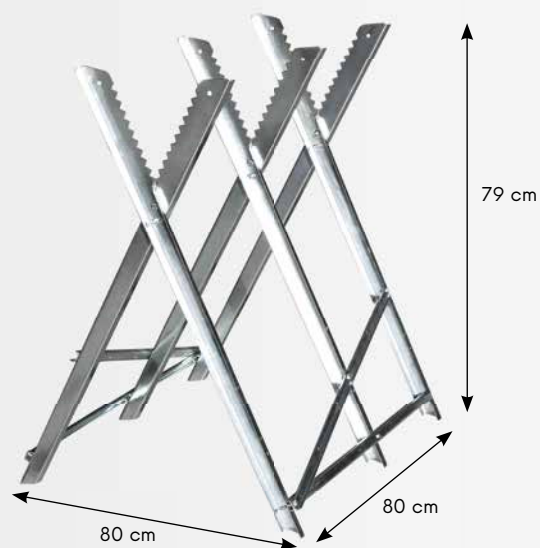

STOJAK DO CIĘCIA DREWNA



N.p.	specyfikacja	
37570	max. 150 kg	3

FESTA

PIŁA KABŁĄKOWA

· hartowane zęby



N.p.	specyfikacja		N.p.	specyfikacja	
24141	450 mm	12	24136	760 mm	12
24140	533 mm	12	24142	800 mm	12
24135	610 mm	12	24137	914 mm	12

FESTA

PIŁA KABŁĄKOWA

· hartowane zęby



N.p.	specyfikacja	
24173	350 mm	24

PIŁA OGRODOWA KABŁĄKOWA



N.p.	specyfikacja	
24151	300 mm	10

PIŁA OGRODOWA KABŁĄKOWA



N.p.	specyfikacja	
24150	300 mm	5

PIŁA

N.p.	specyfikacja	
24128	450 mm plátky 24192	6



FESTA

PIŁA OGRODOWA SKŁADANA



3 x szlifowane, hartowane zęby



N.p.	specyfikacja	
45061	150 mm z osłoną rękojeść	12



FESTA

PIŁA OGRODOWA SKŁADANA



3 x szlifowane, hartowane zęby



N.p.	specyfikacja	
45060	180 mm	6



FESTA

PIŁA OGRODOWA



3 x szlifowane, hartowane zęby



N.p.	specyfikacja	
45062	260 mm z pochwą	24



PIŁA OGRODOWA



3 x szlifowane, hartowane zęby



N.p.	specyfikacja	
24152	350 mm 6 tpi	12

FESTA

PIŁA TELESKOPOWA DO GAŁĘZI



3 x szlifowane, hartowane zęby



N.p.	specyfikacja	
45033	230 - 490 mm	1



NOŻYCE DO GAŁĘZI



N.p.	specyfikacja	
45030	piłka 30 cm kij teleskopowy 260 cm	6
45031	piłka 30 cm	6

NOŻYCE DO GAŁĘZI



N.p.	specyfikacja	
45032	metalowe bez piłki	6

FESTA

PIŁA DO POLYSTYRENU



N.p.	specyfikacja	
24174	380 mm	1

FESTA

PIŁA DO POROBETONU



N.p.	specyfikacja	
24181	550 mm	1

FESTA

PIŁA DO GAZOBETONU



N.p.	specyfikacja	
24158	22 22 SK zębów - 450 mm	5

FESTA

PIŁA DO GAZOBETONU

· hartowane zęby



N.p.	specyfikacja	
24175	bez SK zębów - 600 mm EU	2
24178	bez SK zębów - 600 mm	6

FESTA

PIŁA DO PŁYT GIPS-KARTON



· 3 x szlifowane, hartowane zęby

N.p.	specyfikacja	
24159	150 mm	12

FESTA

PIŁKA DO PŁYT KARTONOWO - GISOWYCH



N.p.	specyfikacja	
24190	270 mm	10

FESTA

PIŁA DO GAZOBETONU



N.p.	specyfikacja	
24155	34 17 SK zębów - 600 mm	2
24156	34 34 SK zębów - 600 mm	2

FESTA

PIŁA DO GAZOBETONU

N.p.	specyfikacja	
24176	34 17 SK zębów - 750 mm	6
24177	34 34 SK zębów - 750 mm	6





FESTA

MŁOTEK ŚLUSARSKI

· jesionowy trzonek

DIN 1041

N.p.	specyfikacja	
19081	100 g	1
19082	200 g	1
19083	300 g	1
19084	400 g	1
19085	500 g	1
19086	600 g	1
19088	800 g	1
19090	1000 g	1
19092	1500 g	1
19095	2000 g	1



FESTA

MŁOTEK

· jesionowy trzonek

DIN 1041

N.p.	specyfikacja	
19096	3000 g	1
19097	4000 g	1
19098	5000 g	1
19106	6000 g	1
19108	8000 g	1
19109	10000 g	1



FESTA

MŁOTEK

· jesionowy trzonek

DIN 6475

N.p.	specyfikacja	
19041	1000 g	1
19042	1250 g	1
19043	1500 g	1
19044	2000 g	1



FESTA

MŁOTEK

· jesionowy trzonek

DIN 6475

N.p.	specyfikacja	
19045	3000 g	1
19046	4000 g	1
19074	5000 g	1
19075	6000 g	1
19076	8000 g	1
19077	10000 g	1



FESTA

MŁOTEK ŚLUSARSKI

· uchwyt fiberglass

Č.p.	specifikace	
19021	100 g	12
19022	200 g	12
19023	300 g	12
19024	400 g	12
19025	500 g	12
19026	600 g	6
19028	800 g	6
19030	1000 g	6
19031	1500 g	6
19032	2000 g	1



FESTA

MŁOTEK KAMIENIARSKI

· uchwyt fiberglass

DIN 6475

Č.p.	specifikace	
19066	1000 g	4
19067	1250 g	4
19068	1500 g	4
19069	2000 g	2

FESTA

MŁOTEK ŚLUSARSKI

· uchwyt fiberglass



Č.p.	specifikace	
19034	3000 g	4
19036	4000 g	4

FESTA

MŁOTEK KAMIENIARSKI

· uchwyt fiberglass

DIN 6475



Č.p.	specifikace	
19070	3000 g	4
19071	4000 g	4
19058	5000 g	4
19059	6000 g	2

FESTA

**MŁOTEK
CIESIELSKI**

· uchwyt fiberglass



Ć.p.	specyfikacja	
19061	600 g	6



FESTA

**MŁOTEK
SZEWSKI**

· uchwyt fiberglass

Ć.p.	specyfikacja	
19064	450 g	6



FESTA

**MŁOTEK
CIESIELSKI
MONOLIT**



Ć.p.	specyfikacja	
19062	600 g	6



FESTA

**MŁOTEK
SZEWSKI
MONOLIT**

Ć.p.	specyfikacja	
19063	450 g	6



**MŁOTEK
CIESIELSKI**



Ć.p.	specyfikacja	
19100	600 g	6



FESTA

**MŁOTEK
MURARSKI
MONOLIT**

Ć.p.	specyfikacja	
19150	600 g	6



FESTA

**MŁOTEK
CIESIELSKI**



Ć.p.	specyfikacja	
19060	600 g	6



FESTA

**MŁOTEK
SZEWSKI**

Ć.p.	specyfikacja	
19065	450 g	6



FESTA

**MŁOTEK
MURARSKI**

· uchwyt fiberglass

Ć.p.	specyfikacja	
19151	600 g	6



FESTA

MŁOTEK MURARSKI

· jesionowy trzonek

Ć.p.	specyfikacja	
19149	44 mm	1



FESTA

MŁOTEK MURARSKI

· jesionowy trzonek

Ć.p.	specyfikacja	
19124	24 mm	1
19136	36 mm	1
19148	48 mm	1



FESTA

MŁOTEK - SIEKIERA

Ć.p.	specyfikacja	
19303	600 g	6



FESTA

MŁOTEK

Č.p.	specifikace	
19051	1000 g	6
19052	1500 g	6



MŁOTEK

· okrągły klin

DIN 6475



Č.p.	specifikace	
19053	1000 g	6
19050	1250 g	6
19054	1500 g	6
19055	2000 g	6



MŁOTEK
SŁUSARSKI

· okrągły klin

DIN 1041

Č.p.	specifikace	
19001	100 g	12
19002	200 g	12
19003	300 g	6
19004	400 g	6
19005	500 g	6
19006	600 g	6
19008	800 g	6
19010	1000 g	6
19015	1500 g	6
19020	2000 g	6



MŁOTEK

· okrągły klin

DIN 6475

Č.p.	specifikace	
19056	3000 g	6
19057	4000 g	6

MŁOTEK
SPAWALNICZY



Č.p.	specifikace	
19115	320 g	1



FESTA

JESIONOWY UCHWYT DO MŁOTKA

N.p.	specyfikacja	
61240	trzonek	1



JESIONOWY UCHWYT



N.p.	specyfikacja	do młotka	
61320	26 cm	19081	10
61321	28 cm	19082	10
61322	30 cm	19083	10
61323	31 cm	19084	10
61324	32 cm	19085	10



N.p.	specyfikacja	do młotka	
61325	33 cm	19086	10
61326	35 cm	19088	10
61327	36 cm	19090	10
61328	38 cm	19092	10
61329	40 cm	19095	10



JESIONOWY UCHWYT DO
MŁOTKA



N.p.	specyfikacja	do młotka	
61330	80 cm	19074, 19075	10
61331	90 cm	19076, 19077	10

KLINY STOŻKOWE

N.p.	specyfikacja	
19430	6 mm	10
19431	8 mm	10
19432	10 mm	10
19433	12 mm	10
19434	14 mm	10
19435	16 mm	10



KLINY



N.p.	specyfikacja	
19440	wąski	10
19441	średkowy	10
19442	szeroki	10
19443	szeroki S	10



FESTA

KLINY



3x

N.p.	specyfikacja	
19398	20 x 25 x 5 mm	1
19399	30 x 40 x 5 mm	1





FESTA



FESTA

MŁOTEK DREWNIANY

· bukowy drewno



N.p.	specyfikacja	
19202	Ø 60 x 120 mm 260 g	1



FESTA

MŁOTEK GUMOWY

· jesionowy trzonek



N.p.	specyfikacja	
19245	Ø 55 mm 400 g	1
19246	Ø 60 mm 800 g	1
19247	Ø 70 mm 1000 g	1
19248	Ø 95 mm 2000 g	1
19249	Ø 115 mm 3000 g	1

FESTA

MŁOTEK GUMOWY

· uchwyt fiberglass



N.p.	specyfikacja	
19270	Ø 55 mm	6
19271	Ø 65 mm	6
19272	Ø 90 mm	6



FESTA

MŁOTEK GUMOWY



N.p.	specyfikacja	
19255	Ø 55 mm	6
19265	Ø 65 mm	6
19290	Ø 90 mm	6



FESTA

MŁOTEK GUMOWY BIAŁY

· uchwyt fiberglass

N.p.	specyfikacja	
19281	680g	6



FESTA

MŁOTEK GUMOWY BIAŁY



N.p.	specyfikacja	
19293	Ø 55 mm	6
19294	Ø 65 mm	6
19295	Ø 90 mm	6



FESTA

MŁOTEK MOSIĘŻNY

· uchwyt fiberglass

N.p.	specyfikacja	
19211	Ø 30 mm 500 g	1



FESTA

MŁOTEK NYLON

· uchwyt fiberglass



N.p.	specyfikacja	
19209	Ø 34 mm	6



MŁOTEK GUMOWY



N.p.	specyfikacja	
19251	Ø 55 mm 400 g	12
19252	Ø 65 mm 700 g	6
19253	Ø 90 mm 1300 g	4



MŁOTEK GUMOWY



N.p.	specyfikacja	
19254	Ø 65 mm	6



FESTA

MŁOTEK Z WYMIENNYMI KOŃCÓWKAMI

- PP - 97 Shore A ·
- TPU - 95 Shore A ·
- TPE - 90 Shore A ·
- TPE - 90 Shore A ·
- TPU - 92 Shore A ·
- TPU - 92 Shore A ·
- TPU - 88 Shore A ·
- TPE - 90 Shore A ·

MŁOTEK SILIKONOWY

N.p.	specyfikacja	
19297	Ø 30 mm	12



N.p.	specyfikacja	
19208	Ø 38 mm	1

ZESTAW
MŁOTKÓW
BLACHARSKICH

7x

N.p. specyfikacja
19110



FESTA

ŁAPKA DO GWOŹDZI



N.p.	specyfikacja	box
19420	300 mm	1



FESTA

ŁAPKA DO GWOŹDZI

N.p.	specyfikacja	box
19424	400 mm	6
19425	600 mm	6
19426	800 mm	6
19427	1000 mm	6



ŁAPKA DO
GWOŹDZI

N.p.	specyfikacja	box
19416	600 mm Ø 16 mm	4
19422	800 mm Ø 16 mm	4
19421	1000 mm Ø 18 mm	4



ŁAPKA DO
GWOŹDZI

N.p.	specyfikacja	box
19423	380 x 35 x 6 mm	1



FESTA

ŁAPKA DO
GWOŹDZI

N.p.	specyfikacja	box
19415	300 mm Ø 15 mm	6





FESTA

PRZECINAK PŁASKI

CrV	N.p.	specyfikacja	szerokość	
	19406	300 mm	25 mm	5
	19407	400 mm	30 mm	5



FESTA

PUNKTAK

CrV	N.p.	specyfikacja	
	19408	250 mm	5
	19409	350 mm	5



FESTA

PRZECINAK PŁASKI

CrV	N.p.	specyfikacja	szerokość	
	19460	300 mm	25 mm	5
	19470	400 mm	30 mm	5



PUNKTAK

N.p.	specyfikacja	
19400	250 mm	5
19403	350 mm	6



PRZECINAK PŁASKI

N.p.	specyfikacja	szerokość	
19401	250 mm	19 mm	6
19404	350 mm	22 mm	6



PRZECINAK PŁASKI

N.p.	specyfikacja	szerokość	
19402	250 mm	50 mm	2
19405	350 mm	50 mm	6



FESTA

ZESTAW PRZECINAKÓW I WYBIJAKÓW

12x CrV

- 2, 6, 8 mm
- 10, 12, 16 mm
- Ø 1,5-3-4-5-6-8 mm

N.p.	specyfikacja	
19487		4



FESTA

ZESTAW PRZECINAKÓW I WYBIJAKÓW

6x CrV

- 2 x 140, 8 x 115 mm
- 12 x 152, 10 x 142 mm
- Ø 3 x 152, 6 x 152 mm

N.p.	specyfikacja	
19486		10



FESTA

ZESTAW PRZECINAKÓW

3x CrV

- 10, 12, 16 mm

N.p.	specyfikacja	
19485		10



FESTA

DŁUTO PUNKTOWE

CrV

N.p.	specyfikacja	
19429	200 mm	1



FESTA

PRZECINAK PŁASKI

CrV

N.p.	specyfikacja	szerokość	
19410	200 mm	20 mm	10
19411	250 mm	25 mm	10
19412	300 mm	25 mm	10
19418	400 mm	25 mm	5
19419	500 mm	25 mm	5



PRZECINAK PŁASKI

CrV

N.p.	specyfikacja	szerokość	
19436	200 mm	20 mm	15

FESTA
DOBIJAKI



CrV 3x

N.p.	specyfikacja	
19480	Ø 0,8, 1,5, 2,5 mm	10

FESTA
PUNKTAKI



CrV 3x

N.p.	specyfikacja	
19481	Ø 0,8, 1,5, 2,5 mm	10

FESTA
ZESTAW WYBIJAKÓW



CrV 6x

N.p.	specyfikacja	
19483	Ø 3, 4, 5, 6, 7, 8 mm	5

FESTA
WYBIJAKI



CrV

N.p.	specyfikacja	
19472	Ø 4 mm 150 mm	1
19473	Ø 5 mm 150 mm	1
19474	Ø 6 mm 150 mm	1

FESTA
PUNKTAKI



CrV

N.p.	specyfikacja	
19477	Ø 2,5 mm	20

FESTA
PUNKTAK AUTOMATYCZNY



CrV

N.p.	specyfikacja	
19478	Ø 2,5 mm	12

NÓŻ DO SZKŁA



N.p.	specyfikacja	
20350	130 mm	12

DZIURKACZE



- 24690 - Ø 2,5 mm
- Ø 3 mm
- Ø 4 mm
- Ø 5 mm
- Ø 6 mm
- Ø 7 mm
- Ø 8 mm
- Ø 9 mm
- Ø 10 mm
- 24691 - Ø 2 mm
- Ø 2,5 mm
- Ø 3,2 mm
- Ø 4 mm
- Ø 4,8 mm
- Ø 5 mm
- Ø 6,4 mm
- Ø 8 mm
- Ø 9,5 mm
- Ø 11,1 mm
- Ø 12,7 mm
- Ø 14 mm
- Ø 15,8 mm
- Ø 19 mm
- Ø 22 mm



N.p.	specyfikacja	
24690	9 szt. Ø 2,5 - 10 mm	10
24691	15 szt. Ø 2 - 22 mm	5

DZIURKACZE

N.p.	specyfikacja	
13x 24695	Ø 5, 6, 8, 10, 11, 13, 16, 19, 22, 25, 28, 32, 35 mm	5

MATRYCA CYFRY

N.p.	specyfikacja	
20972	6 mm	5
20973	8 mm	5



MATRYCA LITERY

N.p.	specyfikacja	
20970	6 mm	5
20971	8 mm	5





ŚCISK JEDNORĘCZNY

N.p.	specyfikacja	
23625	150 mm	6
23626	300 mm	6
23628	450 mm	6
23630	600 mm	6
23632	760 mm	6



NEW



PRZEDŁUŻACZ DO ZACISKÓW

FESTA INDUSTRY 23625, 23626, 23628, 23630

2x



N.p.	specyfikacja	
23635		6



ZACISK SZYBKO-MOCUJĄCY



N.p.	specyfikacja	
23570	100 x 80 mm	1
23571	160 x 80 mm	1
23572	200 x 80 mm	1
23573	250 x 80 mm	1
23574	300 x 80 mm	1

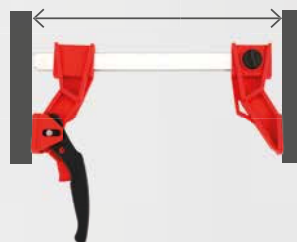

ŚCISK ŚRUBOWY

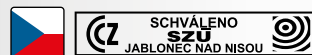

N.p.	specyfikacja	
23670	150 x 105 mm	1
23671	200 x 105 mm	1
23672	250 x 105 mm	1
23673	300 x 105 mm	1
23674	350 x 105 mm	1
23675	400 x 175 mm	1
23676	500 x 175 mm	1
23677	600 x 175 mm	1
23678	700 x 175 mm	1
23679	800 x 175 mm	1
23680	1000 x 175 mm	1
23681	1250 x 175 mm	1
23682	1500 x 175 mm	1
23683	1750 x 175 mm	1
23684	2000 x 175 mm	1
23685	2200 x 175 mm	1



ŚCISK JEDNORĘCZNY

N.p.	specyfikacja	
23585	150 mm	6
23587	300 mm	6
23589	450 mm	6
23591	600 mm	6



FESTA

ŚCISK JEDNORĘCZNY

• kute

N.p.	specyfikacja	
23560	200 x 80 mm	1
23561	300 x 100 mm	1
23562	400 x 100 mm	1
23563	500 x 120 mm	1
23564	600 x 120 mm	1
23565	800 x 120 mm	1
23566	1000 x 120 mm	1



ŚCISK ŚRUBOWY

DIN 5117

N.p.	specyfikacja	
23506	300 x 120 mm	10
23507	500 x 120 mm	10
23508	800 x 120 mm	6



ŚCISK ŚRUBOWY

N.p.	specyfikacja	
23515	150 x 50 mm	50
23520	200 x 50 mm	50
23525	250 x 50 mm	50
23530	300 x 50 mm	50
23531	300 x 120 mm	20
23551	500 x 120 mm	10



NEW



FESTA

ZACISKI DO STOŁU WARSZTATOWEGO

N.p.	specyfikacja	
23595	250/Ø 20 mm 60 kg	1



NEW



FESTA

ZACISKI DO STOŁU WARSZTATOWEGO

N.p.	specyfikacja	
23598	120/Ø 20 mm 70 kg	1

NEW



FESTA

ZACISK TAŚMOWY DO RAM

N.p.	specyfikacja	
23637	4m x 25mm	1

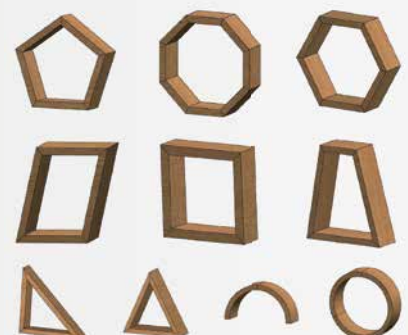



FESTA

90° IMADŁO



4x

N.p.	specyfikacja	
23607	siła mocowania - 250 N	1

ŚCISK ŚRUBOWY 90°

ALU

· zasięg 0 - 65 mm



N.p.	specyfikacja	
23420	65 mm	20



ZACISK SPRĘŻYNOWY

· rozpiętość 80 mm

N.p.	specyfikacja	
23605	9' 230 mm	6

ZACISK SPRĘŻYNOWY

N.p.	specyfikacja	
23600	4', rozpiętość 40 mm	20
23601	6', rozpiętość 70 mm	12
23602	9', rozpiętość 100 mm	20

ZESTAW ŚCISKÓW – G

3x

N.p.	specyfikacja	
23620	25 mm, 50 mm, 75 mm	10



FESTA



208

STÓŁ WARSZTATOWY



212

ŚCISK, IMADŁA



213

PODNOŚNIKI HYDRAU-
LICZNE

218

LAMPY

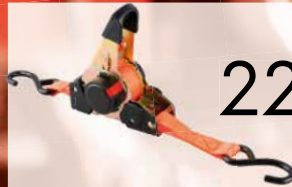

220

PASEK MOCUJĄCY



224

TAŚMA



227

KARABIŃCZYKI WIĘZY I LINY
STAŁOWESNA

230

PRODUKTY
BEZPIECZEŃSTWA

234

SKRZYŃKA NA NARZĘDZIA



237

ZAMEK, KLÓDKA,
BLOKADA ROWEROWA

239

SKARBONKA I SKRZYŃKA
POCZTOWA

WARSZTAT

208 - 243



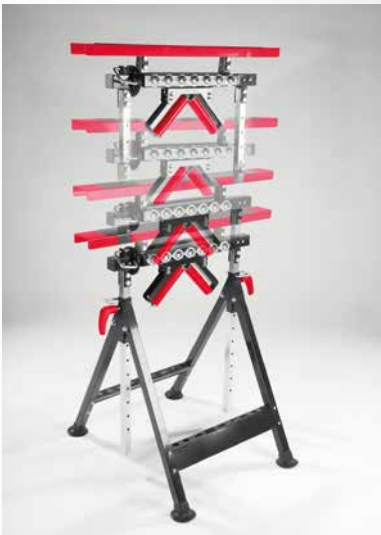

max 200 kg



max 45 kg



max 100 kg



max 100 kg



FESTA

KOZIOŁEK/KOBYŁKA

· maksymalna nośność: 200 kg

N.p. specyfikacja
36410

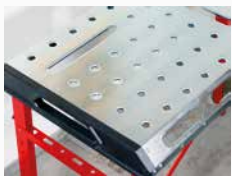

FESTA

SKŁADANY STÓŁ SPAWALNICZY

· maksymalna nośność: 450 kg

N.p. specyfikacja
23652



FESTA

KOZIOŁEK/KOBYŁKA

· maksymalna nośność 590 kg

N.p. specyfikacja
23657



NEW



2x



4x

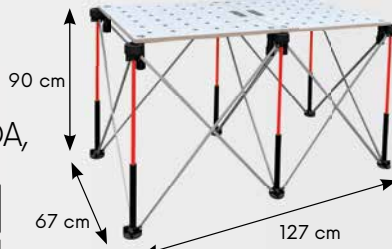

FESTA

PRACUJĄCA PRZENOŚNA STOPEDA, KOMPATYBILNY Z 23664

- 1270 x 670 x 900 mm
- maksymalna nośność: 1100 kg



1

N.p. specyfikacja
23661

NEW



FESTA

BLAT ROBOCZY, KOMPATYBILNY Z 23661

- 1200 x 600 x 18 mm



1

N.p. specyfikacja
23664



FESTA

KOZIOŁEK/KOBYŁKA

- maksymalna nośność: 230 kg



1

N.p. specyfikacja
23658

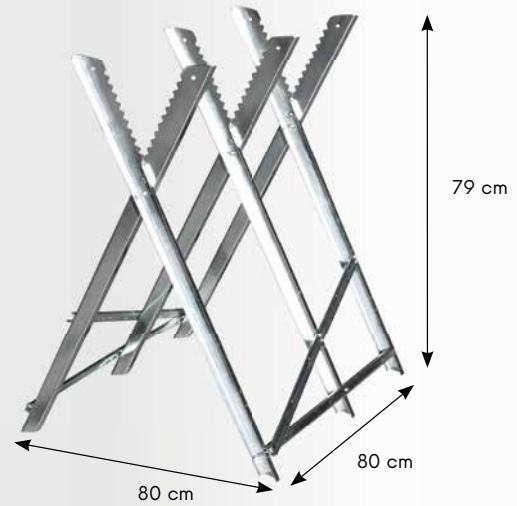

KOZA NA CIĘCIE DREWNA

- maksymalna nośność: 150 kg



1

N.p. specyfikacja
37570



KOZIOŁ BUDOWLANY

- maksymalna nośność: 125 kg



1

N.p. specyfikacja
36300



KOZIOŁEK/KOBYŁKA Z TWORZYWA SZTUCZNEGO

- maksymalna nośność 150kg (300 kg w parze)

2x

N.p. specyfikacja
37560

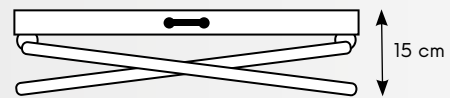
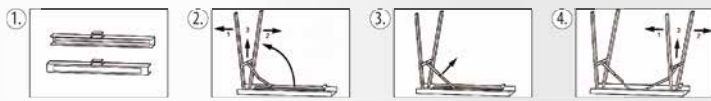
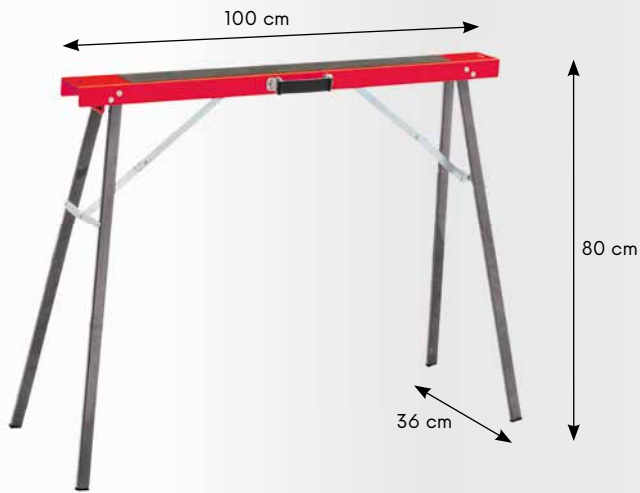

KOZIOŁEK/KOBYŁKA

· maszt. ymalna nośność 125 kg

2x			
N.p.	specyfikacja		
37549	pár	1	

STÓŁ WARSZTATOWY SKŁADANY

· max. 100 kg

N.p.	Specyfikacja	
23655	100 x 50 x 84 cm	1



STÓŁ WARSZTATOWY

· idealny do piwnic

N.p.	specyfikacja	
23660		1



STÓŁ WARSZTATOWY

· maksymalna nośność: 100 kg

N.p.	specyfikacja	
23650		1



KRZESŁO WARSZTATOWE

Wyściełane siedzisko rolkowe z plastikową półką na narzędzia

N.p.	Specyfikacja	
26988	360 x 365 x 365 mm	1

FESTA

LISTWA MAGNETYCZNA



N.p.	specyfikacja	
70098		12





FESTA

WÓZEK NA NARZĘDZIA

N.p.	Przesuw szuflady	Szuflady	wymiary	
26986	gładke	7	680 x 460 x 1020 mm	1



WÓZEK NA NARZĘDZIA

· nadstawka może być chowana w dolnej części wózka

N.p.	specyfikacja	Przesuw szuflady	Szuflady	Wymiary wewnętrzne szuflad SxGxW	wymiary	Waga	
26985	Nadstawka	gładke	3	151,5 x 225 x 40 mm	600 x 260 x 340 mm	11,5 kg	1
			2	511 x 225 x 40 mm			
	szafka dolna	gładke	1	511 x 225 x 85 mm	616 x 330 x 742 mm	16,4 kg	
			2	511 x 308 x 85 mm			



FESTA

PRZENOŚNE IMADŁO STOJĄCE

- zakres: 0 - 95 cm
- maksymalna nośność 250 kg

N.p. Specyfikacja

37553



1



FESTA

IMADŁO

- hartowane szczęki

N.p.	specyfikacja		
23410	100 mm	1	
23411	125 mm	1	
23412	150 mm	1	



IMADŁO OBROTWE

- hartowane szczęki

N.p.	specyfikacja		
23415	100 mm	1	
23416	125 mm	1	
23417	150 mm	1	



IMADŁO OBROTWE

N.p.	specyfikacja		
23407	65 mm	10	



IMADŁO POD WIERTARKE STOŁOWA

- hartowane szczęki

N.p.	specyfikacja		
23400	18 80 mm	10	
23401	22 100 mm	10	
23402	24 125 mm	5	



IMADŁO OBROTWE 360°

ALU	N.p.	specyfikacja		
	23406	80 mm	24	

LEWAREK HYDRAULICZNY

Śruba przedłużająca umożliwia regulację wysokości i podnoszenia
 Podwójny zawór obejściowy bezpieczeństwa
 Ząbkowane siodełko zapewnia obfite podnoszenie i bezpieczny chwyt
 Szeroka podstawa dostarcza stabilności i siły
 Krytyczne obciążenie wszystkich modeli jest wzmacnione dla dodatkowej trwałości i niezawodności



N.p.	obciążenie	min. wysokość	Wysokość podnoszenia	Wysokość regulacji śrubą głowicy	Rozmiar podstawy	waga	
26800	2 000 kg	181mm	116 mm	48 mm	88 x 92 mm	2,6 kg	1
26801	3 000 kg	194 mm	118 mm	60 mm	92 x 100 mm	3,3 kg	1
26802	5 000 kg	216 mm	127 mm	70 mm	96 x 112 mm	4,5 kg	1
26803	8 000 kg	230 mm	147 mm	80 mm	103 x 118 mm	5,7 kg	1
26804	10 000 kg	230 mm	150 mm	80 mm	110 x 123 mm	6,8 kg	1
26805	12 000 kg	230 mm	155 mm	80 mm	116 x 134 mm	7,3 kg	1
26806	15 000 kg	230 mm	150 mm	80 mm	133 x 136 mm	8,4 kg	1
26807	20 000 kg	242 mm	150 mm	60 mm	144 x 152 mm	11 kg	1



LEWAREK HYDRAULICZNY TELESKOPOWY

Śruba przedłużająca umożliwia regulację wysokości i podnoszenia
 Podwójny zawór obejściowy bezpieczeństwa
 Ząbkowane siodełko zapewnia obfite podnoszenie i bezpieczny chwyt
 Szeroka podstawa dostarcza stabilności i siły
 Krytyczne obciążenie wszystkich modeli jest wzmacnione dla dodatkowej trwałości i niezawodności



N.p.	obciążenie	min. wysokość	Wysokość podnoszenia	Wysokość regulacji śrubą głowicy	waga	
26815	2 000 kg	150 mm	160 mm	60 mm	4,7 kg	1
26816	4 000 kg	160 mm	170 mm	60 mm	6,4 kg	1
26817	6 000 kg	215 mm	270 mm	-	8,9 kg	1
26819	10 000 kg	228 mm	284 mm	89 mm	10,2 kg	1



LEWAREK ŚRUBOWY



N.p.	obciążenie	min. wysokość	max. wysokość	waga	
26844	1 000 kg	88 mm	380 mm	2,5 kg	1
26845	2 000 kg	120 mm	395 mm	3,5 kg	1



LEWAREK HYDRAULICZNY „ŻABA”



N.p.	specyfikacja	obciążenie	min. wysokość	max. wysokość	waga	
26820	lewarek hydrauliczny przenośny	2 000 kg	130 mm	345 mm	9,6 kg	1
26822	lewarek hydrauliczny przenośny	3 000 kg	130 mm	465 mm	27,4 kg	1
26826	lewarek hydrauliczny, niski profil, rączka obrotowa 360°	2 000 kg	89 mm	359 mm	14,2 kg	1
26824	lewarek hydrauliczny z „nożnym pedałem”	3 000 kg	145 mm	500 mm	37,2 kg	1
26825	lewarek hydrauliczny, niski profil, profi	2 500 kg	85 mm	455 mm	34,8 kg	1

LEWAREK HYDRAULICZNY „ŻABA” + STOJAKI

· rączka obrotowa 360°



N.p.	obciążenie	min. wysokość	max. wysokość	waga	
26829	2 000 kg	130 mm	350 mm	10,5 kg	1
	2 000 kg	275 mm	420 mm	5 kg (pair)	

STOJAK POD LEWAREK

1 para
Zapadkowy typ do precyzyjnej regulacji z podwójnym zabezpieczeniem
Solidny stalowy uchwyt
Duże siodełko
Jednolita konstrukcja ramy



N.p.	specyfikacja	obciążenie	min. wysokość	max. wysokość	waga	
26857	z zawleczką	2 000 kg	275 mm	420 mm	4,8 kg	1
26858	z zawleczką	3 000 kg	285 mm	425 mm	6,3 kg	1
26859	z zawleczką	6 000 kg	393 mm	593 mm	13 kg	1
26853		12 000 kg	465 mm	715 mm	28 kg	1

PODNOŚNIK HYDRAULICZNY Z WYSIĘGNIKIEM

Do podnoszenia i naprawiania jednostek podczas montażu i demontażu z samochodów
Wysięgnik kranu ma kilka pozycji przedłużenia
Kran może być łatwo złożony do przechowania

N.p.	obciążenie	min. wysokość	max. wysokość	waga	
26862	2 000 kg	0	2360 mm	88 kg	1



URZĄDZENIE DO USTAWIANIA SILNIKA W POZIOMIE

Ruchome(wahliwe) zawieszenie ramienia, zależne od nachylenia maski
Zapewnia zawsze zbalansowane i stabilne naprawy silnika

N.p.	obciążenie	długość	zasięg	waga	
26871	500 kg	1500 mm	150 mm	20,3 kg	1



LEWAREK HYDRAULICZNY OBROTOWY

Łatwe montowanie i demontowanie jednostek (silniki, skrzynie biegów, osie itp)

N.p.	specyfikacja	obciążenie	długość	zasięg	waga
26880	lewarek hydrauliczny obrotowy	500 kg	1100 mm	1900 mm	30,0 kg



26880

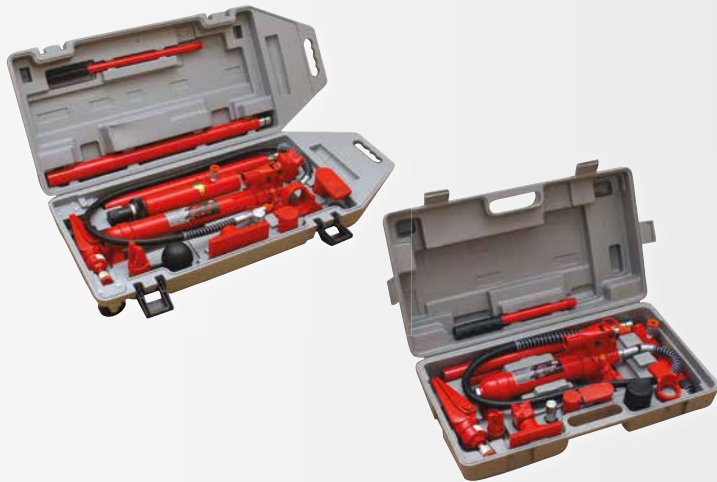

PRZENOŚNY ZESTAW NAPRAWCZY

- zestaw urządzeń hydraulicznych do naprawy pojazdów
- składa się z rozpieraka hydraulicznego oraz 14 akcesoriów
- umożliwia szeroką gamę zastosowań przy naprawie samochodów i ciężarówek w warunkach polowych, szczególnie cenny w sytuacji braku energii elektrycznej
- akcesoria z zestawu pozwalają na ściskanie, ciągnięcie, podnoszenie i rozciąganie w kierunkach poziomym i pionowym
- łatwy transport zapewnia plastikowa walizka

N.p.	obciążenie	Wysokość podnoszenia	waga	
26886	4 000 kg	125 mm	17,0 kg	1
26888	10 000 kg	135 mm	32,0 kg	1



STOJAK NA SILNIK

Ruchomy stojak do montażu i pracy na zdemontowanych silnikach
Uniwersalna jednostka zaciskowa dla spięcia silnika i jego rozruchu

N.p.	obciążenie	waga	
26920	450 kg	20 kg	1



HYDRAULICZNA GIĘTARKA DO RUR

N.p.	Obciążenie	Wysokość	Segmety gnące	Waga	
26895	12 000 kg	232 mm	1½", ¾", 1", 1-1¼", 1-1½", 2"	36 kg	1
26896	16 000 kg	238 mm	1½", ¾", 1", 1-1¼", 1-1½", 2", 2-1½", 3"	65 kg	1



ŚCIĄGACZ DO SPRĘŻYN HYDRAULICZNYCH MC PHERSON

- 26897 - do demontażu sprężyn mcphersona poza pojazdem. solidna stalowa podstawa zapewnia najwyższą stabilność.
- 26943 - demontaż mcpherson sprężyny na zewnątrz pojazdu. stałe działy stali dla większej stabilności.

N.p.	Obciążenie	Ø max. rozstaw robozy	średnica sprężyn	Waga	
26897	1 000 kg	100-200 mm	150 mm	24,5 kg	1
26943	1 000 kg	400 mm	210-570 mm	35 kg	1



ZBIORNIK NA ZUŻYTY OLEJ SILNIKOWY

Olej jest spuszczaony z silnika do kolektora poprzez łożysko
Kolektor jest dopasowany z wyposażeniem wyciągającym
Olej może być wypompowany z kolektora za pomocą sprężonego powietrza poprzez złączkę

N.p.	objętość	Max.ciśnienie	Waga	
26954	90 l	0,5 MPa	28 kg	1



PRASA HYDRAULICZNA

N.p.	Zasięg	Max. obciążenie	Waga	
26940	0 - 610 mm	12 000 kg	43 kg	1
26941	0 - 880 mm	20 000 kg	75 kg	1

ROZPIERAK HYDRAULICZNY



N.p.	specyfikacja	Obciążenie	Min. długość (mm) Min. length	Max. długość (mm) Max. length	Waga	
26911	pompy pojedyncz	5 000 kg	620	1100	12 kg	2
26912	pompy pojedyncz	8 000 kg	620	1100	13 kg	2
26914	podwójne pompy	5 000 kg	620	1100	12 kg	2
26915	podwójne pompy	8 000 kg	620	1100	14 kg	2

SPARE PARTS FOR
SANDBLASTING CABINET

N.p.	specyfikacja	
26973	gloves	1
26974	nozzles	1
26975	foil 53,5 x 26 cm	1
26976	plexiglass 60 x 30 cm	1
26977	glass 60 x 30 cm	1

KABINA DO PIASKOWANIA 220 L

N.p.	Zużycie powietrza	Wymiary zewnętrzne	Wymiary wewnętrzne	Max. ciśnienie	Waga	
26972	420-710 l/min.	1500 x 830 x 630 mm	600 x 840 x 630 mm	8 bar	38 kg	1

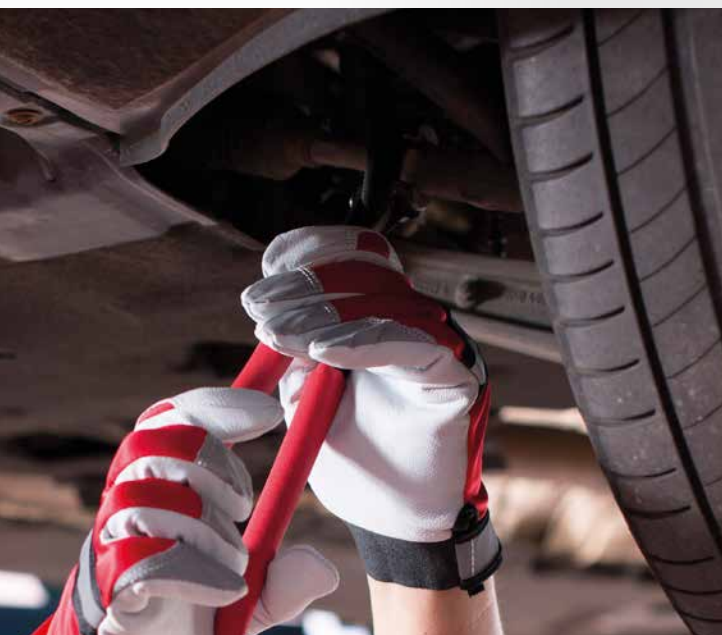

URZĄDZENIE DO MYCIA CZĘŚCI SAMOCHODOWYCH

Do mycia przedmiotów użytku codziennego (części, akcesoria...)



N.p.	całkowita objętość	objętość płynu czyszczącego	Przepływ	Max. Temperatura płynu	Waga	
26961	90 l	45 l	10-12 l/min.	50°C	25 kg	1
26963	180l	150 l	20 l/min	50°C	42 kg	1



OLEJARKA

N.p.	specyfikacja	
50020	300 ml	10



SMAROWNICA RĘCZNA

- ładowanie zbiorcze
- ładowanie wkładu
- ładowanie za pomocą dozownika

N.p.	specyfikacja	
50022	400 ml	20



POMPA RĘCZNA DO

N.p.	specyfikacja	
50017		10



OLEJARKA

N.p.	specyfikacja	
50019	90 ml	1



KLUCZ DO FILTRA

N.p.	specyfikacja	
50021	60 x 140 mm	6



LEJEK

N.p.	specyfikacja	
50025	60 x 140 mm	50



WĄŻ PRZESYŁOWY Z ZAWOREM SAMOZASYSAJĄCYM

N.p.	długość	∅	
50026	180 cm	15 mm	24



MISKA MAGNETYCZNA

N.p.	specyfikacja	
26996	200 x 20 mm	1

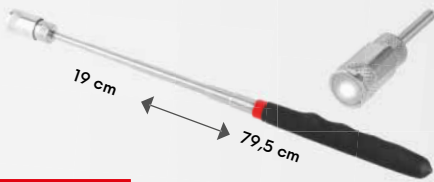

FESTA

MAGNES TELESKOPOWY LED

N.p.	specyfikacja	
13294	3x LR44	6

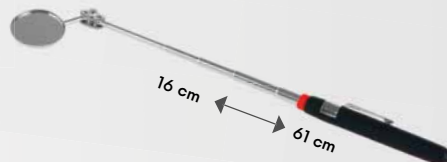

LUSTERKO INSPEKCYJNE, TELESKOPOWE

N.p.	specyfikacja	
13290		20

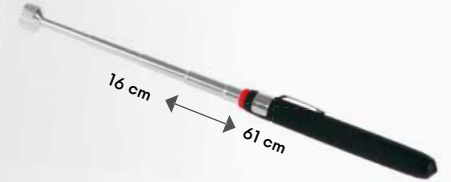

MAGNES TELESKOPOWY

N.p.	specyfikacja	
13293		20



ŁAPKA DO PODNOSZENIA ŚMIECI
· obrotowy o 90 °

N.p.	długość	
61235	81 cm	12

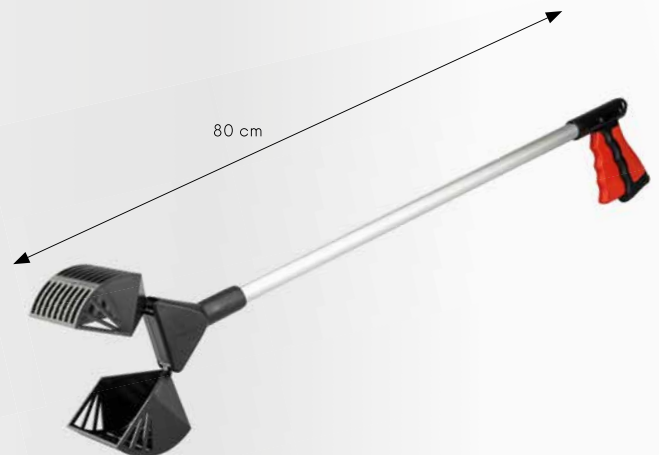

ŁAPKA DO PODNOSZENIA ŚMIECI
· max. 4 kg

N.p.	
61236	12

FESTA



NEW



80 lm



300 lm



200 lm



158 mm

301 mm

FESTA
INDUSTRY

LED LATARKA



3xLED



80, 200, 300 lm



3W COB LED



USB TYPE C



Li-ion 3.7V



0.8Ah



120 min



0-180°



95g



IK07



IP54



N.p. 37647 specyfikacja 3,7V 800 mAh

1



FESTA

LED LATARKA



N.p. specyfikacja
37645 200 mm 3 x AAA 12

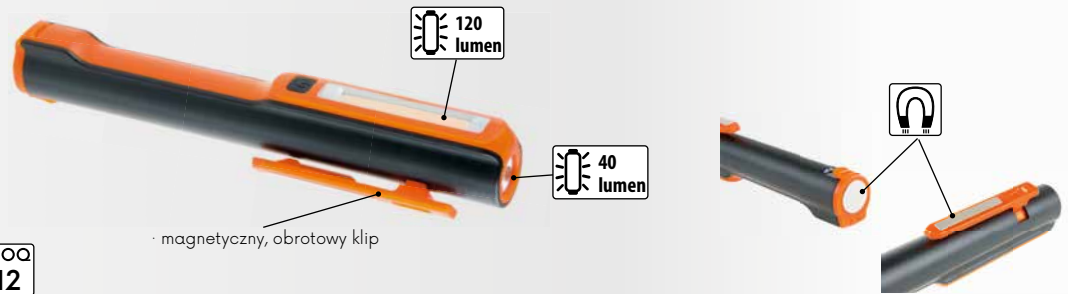

FESTA

LED LATARKA

waga	47 g
źródło światła	1 x 1 W white LED + 2x red LED
bateria	3 x AAA
wymiary	40 x 59 x 32 mm
czas oświetlenia	45 h
jasność	120 lumen
zasięg	60 m (100% battery)
ilość programów	4

· 5 positions

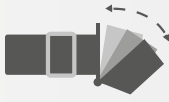

N.p. specyfikacja
37641 2 rodzaje światła, biały i czerwony 1

FESTA

LED LATARKA

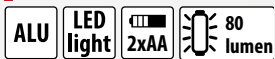

N.p. specyfikacja
37630 185 mm 2 x AA 20



FESTA

LED LATARKA



N.p. specyfikacja
37650 12



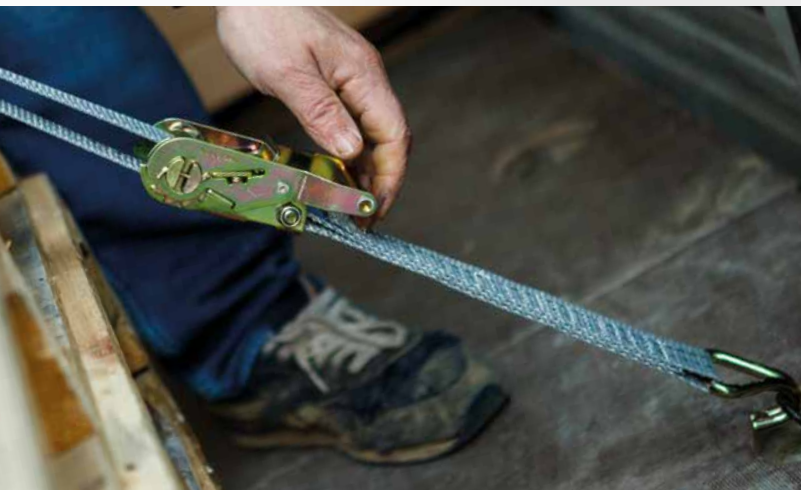

FESTA

PAS TRANSPORTOWY



2x



N.p.	szerokość	długość	ładowność	szt.	
51070	18 mm	2 m	100 kg	2	12

FESTA

PAS TRANSPORTOWY



N.p.	szerokość	długość	ładowność	szt.	
51071	25 mm	3,5 m	300 kg	1	8

FESTA

PAS TRANSPORTOWY



N.p.	szerokość	długość	ładowność	szt.	
51072	35 mm	4 m	500 kg	1	6

FESTA

PAS TRANSPORTOWY



N.p.	szerokość	długość	ładowność	szt.	
51040	25 mm	6 m	1000 kg	1	1
51041	35 mm	8 m	2000 kg	1	1
51042	35 mm	8 m	3000 kg	1	1
51043	50 mm	10 m	5000 kg	1	1

FESTA

PAS TRANSPORTOWY



2x



N.p.	szerokość	długość	ładowność	szt.	
51060	25 mm	5 m	750 kg	2	5

FESTA

PAS TRANSPORTOWY



N.p.	szerokość	długość	ładowność	szt.	
51065	50 mm	10 m	960 kg	1	6

FESTA

PAS TRANSPORTOWY



N.p.	szerokość	długość	ładowność	szt.	
51026	75 mm	5 m	3000 kg	1	4

FESTA

PAS TRANSPORTOWY

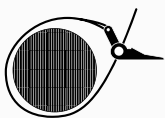

N.p.	szerokość	długość	ładowność	szt.	
51032	25 mm	5 m	500 kg	1	6

FESTA

PAS TRANSPORTOWY



N.p.	szerokość	długość	ładowność	szt.	
51017	50 mm	6 m	480 kg	2	5
51018	50 mm	6 m	480 kg	1	10



**PAS
TRANSPORTOWY**

N.p.	szerokość	długość	specyfikacja	szt.
51022	25 mm	5 m	z haczykami	40
51023	50 mm	5 m	z haczykami	12

FESTA

**PAS
TRANSPORTOWY**
miękką podkładką EVA



N.p.	szerokość	długość	szt.
51046	38 mm	4 m	1 20



**PAS
TRANSPORTOWY**

N.p.	szerokość	długość	specyfikacja	szt.
51030	50 mm	6 m	z haczykami	20
51034	50 mm	8 m	z haczykami	10

**PAS
TRANSPORTOWY**

2x



N.p.	szerokość	długość	szt.
51020	25 mm	2,5 m	2 100



**PAS
TRANSPORTOWY**

PE

N.p.	szerokość	długość	szt.
51045	25 mm	4 m	1 50

**GUMY
ZABEZPIEZAJĄCE**

2x



N.p.	długość	Ø	szt.
51013	1,2 m	8 mm	2 1



**GUMY
ZABEZPIEZAJĄCE**

2x

N.p.	długość	szt.
51008	1 m	2 25



**GUMY
ZABEZPIEZAJĄCE**

N.p.	długość	Ø	szt.
51009	1 m	10 mm	1 25



**GUMY
ZABEZPIEZAJĄCE**

8x

- 2 x 0,4 m
- 2 x 0,6 m
- 1 x 0,8 m
- 1 x 1,0 m

N.p.	długość	Ø	szt.
51011	1 m	8 mm	8 10

**GUMY
ZABEZPIEZAJĄCE**

2x

N.p.	długość	Ø	szt.
51001	80 cm	10 mm	2 50
51002	100 cm	10 mm	2 50
51003	150 cm	10 mm	2 50
51004	200 cm	10 mm	2 50



**GUMY
ZABEZPIEZAJĄCE**

2x

N.p.	długość	Ø	szt.
51007	1 m	8 mm	2 25

**ŚCIĄGACZE DO
BAGAŻU – PAJĄK**

N.p.	długość	Ø	specyfikacja	szt.
51010	80 cm	8 mm	8 pasek	50



ELASTYCZNA SIATKA Z HAKIEM



N.p.	długość	szerokość	
51015	80 cm	120 cm	20

LINA ELASTYCZNA



N.p.	długość	Ø	
51036	20 m	8 mm	10
51037	20 m	10 mm	6

ZAPASOWE HAKI



20x

N.p.	Ø	
51038	10 mm	30

SZEKLA



ALU

MOQ 2

N.p.	Ø	długość	
51200	6 mm	60 mm	2
51202	7 mm	70 mm	2
51201	8 mm	80 mm	2
51203	10 mm	100 mm	2

LINA PRZEMYSŁOWA



N.p.	długość	Ø	
50915	5 m	8 mm	1
50916	25 m	8 mm	1
50917	25 m	10 mm	1
50918	25 m	12 mm	1
50919	25 m	14 mm	1

LINKA NYLONOWA

N.p.	długość	Ø	
51055	80 m	1,5 mm	50
51056	50 m	2 mm	50
51057	20 m	4 mm	50



LINKA NYLONOWA

N.p.	długość	Ø	
51050	50 m	8 mm	10
51051	50 m	10 mm	4



SZNUREK POLIPROPYLENOWY

N.p.	waga	
50905	80 g	80
50906	100 g	100
50907	200 g	50



SZNUREK POLIPROPYLENOWY

N.p.	waga	
50909	500 g (250 m)	1
50910	1000 g (500 m)	1
50911	5000 g (2500 m)	1



SZNUREK JUTOWY

N.p.	waga	
50900	80 g (61 m)	1
50901	100 g (76 m)	1
50902	200 g (153 m)	1



SZNUREK WOSKOWANY

N.p.	długość	Ø	
50920	50 m	1 mm	80



DRUT MOCUJĄCY ZA WORKI NA ŚMIECI

1000x

N.p.	specyfikacja	
42365	1,25 100 mm	1
42366	1,25 125 mm	1
42367	1,25 140 mm	1
42368	1,25 160 mm	1



DRUT MOCOWANIA

N.p.	specyfikacja	
50052		12
50050		1



DRUT MOCOWANIA

N.p.	specyfikacja	
50051		2



PASKI MOCUJĄCE

50x		EN 50146 nylon	
N.p.	długość	szerokość	
23875	120 mm	4,8 mm	1



PASKI MOCUJĄCE, KOLOR

100x		EN 50146 nylon	
N.p.	długość	szerokość	
23880	100 mm	2,5 mm	1
23882	150 mm	2,5 mm	1
23884	200 mm	3,6 mm	1



PASKI MOCUJĄCE, BIAŁE

50x		EN 50146 nylon	
N.p.	długość	szerokość	
23850	120 mm	2,5 mm	1
23854	200 mm	3,6 mm	1
23856	250 mm	3,6 mm	1
23858	250 mm	4,8 mm	1
23860	300 mm	4,8 mm	1
23864	400 mm	4,8 mm	1
23866	500 mm	4,8 mm	1
23868	400 mm	7,6 mm	1
23870	500 mm	7,6 mm	1



PASKI MOCUJĄCE, CZARNE

50x		EN 50146 nylon	
N.p.	długość	szerokość	
23810	120 mm	2,5 mm	1
23814	200 mm	3,6 mm	1
23816	250 mm	3,6 mm	1
23818	250 mm	4,8 mm	1
23820	300 mm	4,8 mm	1
23824	400 mm	4,8 mm	1
23826	500 mm	4,8 mm	1
23828	400 mm	7,6 mm	1
23830	500 mm	7,6 mm	1



PASKI Z RĄCZKĄ

10x			
N.p.	długość	szerokość	
23865	160 mm	7,5 mm	1



FOLIA

N.p.	szerokość	długość	grubość			
38095	500 mm	600 m	8 μ m	przejrzysty	1	
38097	100 mm	150 m	20 μ m	przejrzysty	1	
38096	500 mm	200 m	23 μ m	czarny	1	



WORKI NA GRUZ

N.p.	szerokość	długość	grubość	objętość	szt.	
39194	500 mm	1100 mm	0,16 mm	100 l	1	10
39196	600 mm	1200 mm	0,16 mm	110 l	1	10
39198	700 mm	1100 mm	0,16 mm	120 l	1	10
39200	500 mm	1100 mm	0,20 mm	100 l	1	10
39202	600 mm	1200 mm	0,20 mm	110 l	1	10
39204	700 mm	1100 mm	0,20 mm	120 l	1	10



WORKI NA GRUZ

N.p.	szerokość	długość	grubość	objętość	szt.	
39195	500 mm	1100 mm	0,16 mm	100 l	1	10
39197	600 mm	1200 mm	0,16 mm	110 l	1	10
39199	700 mm	1100 mm	0,16 mm	120 l	1	10
39201	500 mm	1100 mm	0,20 mm	100 l	1	10
39203	600 mm	1200 mm	0,20 mm	110 l	1	10
39205	700 mm	1100 mm	0,20 mm	120 l	1	10



WORKI NA ŚMIECI

N.p.	szerokość	długość	grubość		szt.	
38060	700 mm	1100 mm	0,08 mm		10	1
38063	700 mm	1100 mm	0,10 mm		3	1
38065	700 mm	1100 mm	0,20 mm		3	1



WORKI NA ŚMIECI

N.p.	szerokość	długość	grubość		szt.	
38050	500 mm	600 mm	0,04 mm		25	1
38052	600 mm	800 mm	0,04 mm		25	1
38054	700 mm	1100 mm	0,04 mm		25	1



WORKI NA ŚMIECI

5x						
N.p.	szerokość	długość	grubość		szt.	
38055	1200 mm	1000 mm	0,08 mm		5	

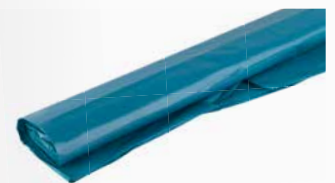



TAŚMA OSTRZEGAWCZA - LINIA NAPIĘCIA

N.p.	szerokość	długość	
38955	22 cm	20 m	1
38956	22 cm	50 m	1



TAŚMA OSTRZEGAWCZA - WODA

N.p.	szerokość	długość	
38957	22 cm	20 m	1
38958	22 cm	50 m	1



TAŚMA OSTRZEGAWCZA - GAZ

N.p.	szerokość	długość	
38959	22 cm	20 m	1
38960	22 cm	50 m	1



TAŚMA OSTRZEGAWCZA

N.p.	specyfikacja	długość	
38944	ZAKAZ WSTĘPU, SK	80 mm 250 m	8
38945	VSTUP ZAKÁZÁN, CZ	80 mm 250 m	8



TAŚMA OSTRZEGAWCZA

N.p.	długość	
38948	80 mm 250 m	8

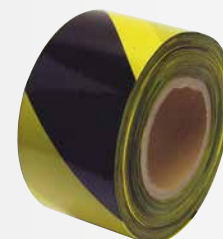

TAŚMA OSTRZEGAWCZA

N.p.	długość	
38946	80 mm 250 m	8



TAŚMA OSTRZEGAWCZA SAMOPRZYLEPNA

N.p.	długość	specyfikacja	
38947	48 mm 33 m	prawy	48
38961	48 mm 33 m	lewy	48



TAŚMA PODŁOGOWA DO WYZNACZANIA

N.p.	szerokość	długość	grubość	
38949	50 mm	50 m	0,15 mm	36

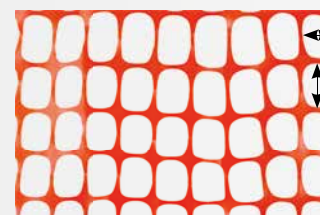

cca 3,5 cm

cca 6,5 cm

OGRODZENIA BEZPIECZENSTWA

N.p.	specyfikacja	
140 g/m ²	UV STABLE	
42190	1,2 x 50 m HDPE 140g/m ²	1



TAŚMA PCV

5x

N.p.	szerokość	długość	grubość	
38931	19 mm	5 m	0,13 mm	100



TAŚMA PCV - CZARNA

N.p.	szerokość	długość	grubość	
38932	19 mm	10 m	0,13 mm	10



TAŚMA PCV

N.p.	szerokość	długość	grubość	
38925	19 mm	10 m	0,13 mm	10



TAŚMA PCV - CZARNA

N.p.	szerokość	długość	grubość	
38968	19 mm	10 m	0,19 mm	10

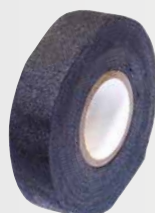

TAŚMA TEKSTYLNA CZARNA

N.p.	szerokość	długość	
38927	19 mm	10 m	10



TAŚMA TEKSTYLNA DYWAN

N.p.	szerokość	długość	
38980	48 mm	10 m	24
38981	48 mm	20 m	24



OBUSTRONNA TAŚMA KLEJĄCA

N.p.	szerokość	długość	
38924	50 mm	10 m	1
38964	50 mm	25 m	1



OBUSTRONNA TAŚMA KLEJĄCA

PP
Polypropylen

N.p.	szerokość	długość	
38929	50 mm	10 m	1
38966	50 mm	25 m	1



DWUSTRONNA TAŚMA KLEJĄCA

MADE IN EU

N.p.	szerokość	długość	
38990	19 mm	5 m	48
38991	25 mm	5 m	36



PROFESJONALNA DUKT TAPE TAŚMA

MADE IN EU

N.p.	szerokość	długość	
38995	48 mm	25 m	24



TAŚMA ALU

N.p.	szerokość	długość	
38965	30 mm	10 m	1
38928	50 mm	10 m	72
38934	50 mm	45 m	24



PROFESJONALNA DUKT TAPE TAŚMA

blue dolphin tapes
MADE IN EU

N.p.	szerokość	długość	
37275	48 mm	50 m	24



TAŚMA MASKUJĄCA, PLASTIKOWA

blue dolphin tapes
UV STABLE
MADE IN EU

N.p.	szerokość	długość	
37271	38 mm	20 m	24
37270	48 mm	20 m	24
37272	48 mm	50 m	24

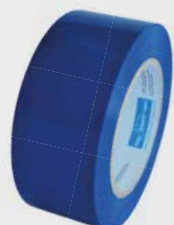

TAŚMA PLASTIKOWA DO OKIEN

przez 30 dni
UV STABLE
MADE IN EU

N.p.	szerokość	długość	
37273	48 mm	50 m	24



TAŚMA MASKUJĄCA, PAPIEROWA

blue dolphin tapes
MADE IN EU

N.p.	szerokość	długość	
37263	38 mm	50 m	24
37264	48 mm	50 m	24



PVC TAŚMA KLEJĄCA

MADE IN EU

N.p.	szerokość	długość	
37266	30 mm	33 m	60
37267	38 mm	33 m	48
37268	50 mm	33 m	36



PAPIEROWA TAŚMA MASKUJĄCA

MADE IN EU

N.p.	szerokość	długość	
37255	19 mm	50 m	12
37256	25 mm	50 m	12
37257	30 mm	50 m	7
37258	38 mm	50 m	6
37259	50 mm	50 m	6



TAŚMA OPAKOWANIOWA PCV

MADE IN EU

N.p.	szerokość	długość	
38942	50 mm	50 m	72



PLATEROWANA TAŚMA



N.p.	szerokość	długość	
38972	50 mm	50 m	1
38973	50 mm	100 m	1



ALU TAŚMA SAMOPRZYLEPNA

ALU

N.p.	szerokość	długość	
38963	48 mm	10 m	1
38943	48 mm	45 m	24



TAŚMA ANTYPOŚLIZGOWA

N.p.	szerokość	długość	grubość	
37280	25 mm	15 m	0,8 mm	72
37281	50 mm	15m	0,8 mm	36



TAŚMA SAMOPRZYLEPNA GIPS-KARTON



TAŚMA SAMOWULKANIZACYJNA

N.p.	szerokość	długość	
38930	19 mm	5 m	100

N.p.	szerokość	długość	
38935	50 mm	20 m	60
38937	50 mm	45 m	36
38939	50 mm	90 m	24
38940	50 mm	153 m	24



TAŚMA WŁOKNO SZKLANE



N.p.	szerokość	długość	
38941	50 mm	25 m	40



TAŚMA TEFLONOWA

TEFLON

N.p.	szerokość	długość	grubość	
38969	19 mm	15 m	0,2 mm	10



TAŚMA TEFLONOWA

TEFLON

N.p.	szerokość	długość	grubość	
38933	12 mm	10 m	0,075 mm	10



TEFLONOWA NIĆ

· lub instalacje wodne i gazowe

TEFLON

N.p.	szerokość	długość	
38926	2 mm	150 m	20

FESTA

TEFLONOWA NIĆ

· 160m
· -20°C ... +130°C
· max 16 bar



N.p.	specyfikacja	
38975		1



DOZOWNIK TAŚMY

N.p.		
38985		1



TAŚMA RZEPOWA

N.p.	specyfikacja	
45471	12 mm x 5 m	1



FESTA

TAŚMA RZEPOWA 3 SZT

3x

N.p.	szerokość	długość	
37295	20 mm	150 mm	1
37296	20 mm	200 mm	1
37297	20 mm	250 mm	1

ŚRUBA NAPINAJĄCA

DIN 1480 Zn

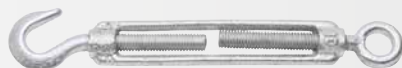

N.p.	specyfikacja	
50100	5 x 70 mm	10
50101	6 x 90 mm	10
50102	8 x 125 mm	10
50103	10 x 150 mm	10

N.p.	specyfikacja	
50104	12 x 200 mm	10
50106	16 x 230 mm	10
50108	20 x 220 mm	10

SZEKLA

DIN 5299 C Zn



N.p.	specyfikacja	
51204	4 mm	10
51205	5 mm	10
51206	6 mm	10
51207	7 mm	10
51208	8 mm	10

N.p.	specyfikacja	
51209	9 mm	10
51210	10 mm	10
51211	11 mm	10
51212	12 mm	10

UCHWYT

Zn



N.p.	specyfikacja	
51241	4 mm	10
51242	5 mm	10
51243	6 mm	10
51244	7 mm	10

N.p.	specyfikacja	
51245	8 mm	10
51246	10 mm	10
51247	12 mm	10

S HAK

Zn



N.p.	specyfikacja	
51271	3 mm	10
51272	4 mm	10
51273	5 mm	10
51274	6 mm	10

N.p.	specyfikacja	
51275	7 mm	10
51276	8 mm	10
51278	10 mm	10

NAKRĘTKA OCZKOWA

DIN 5820 Zn



N.p.	specyfikacja	
51320	6 mm	10
51321	8 mm	10
51322	10 mm	10
51323	12 mm	10

N.p.	specyfikacja	
51324	14 mm	10
51325	16 mm	10
51327	20 mm	10

ŚRUBA OCZKOWA

DIN 5820 Zn



N.p.	specyfikacja	
51300	6 mm	10
51301	8 mm	10
51302	10 mm	10
51303	12 mm	10
51304	14 mm	10

N.p.	specyfikacja	
51305	16 mm	10
51306	18 mm	10
51307	20 mm	10
51308	22 mm	10



SZEKLA

Zn

N.p.	specyfikacja	
51220	53 mm	10
51221	67 mm	10
51222	76 mm	10



UCHWYT OBROTOWY

Zn

N.p.	specyfikacja	
51225	3,8 mm	10
51226	4,5 mm	10
51227	6,0 mm	10



ŁĄCZNIK DO LIN POJEDYNCZY

DIN 5685 C Zn

N.p.	specyfikacja	
51341	Ø 10 mm	10



BLOKADA LINY

Zn

No.	specification	
51280	3 mm	10
51281	5 mm	10
51282	6 mm	10
51283	8 mm	10
51284	10 mm	10
51286	12 mm	10
51287	14 mm	10
51288	16 mm	10



OCZKO DO LINY

Zn

N.p.	specyfikacja	
51258	Ø 16 mm	10
51259	Ø 18 mm	10
51260	Ø 20 mm	10
51261	Ø 22 mm	10
51262	Ø 24 mm	10
51264	Ø 28 mm	10

WYCIĄGARKA ŁAŃCUCHOWA

N.p.	Obciążenie	Min. wysokość	Wysokość podnożenia	Liczba rolek	średnica drutu	Waga	
26700	500 kg	280 mm	3 000 mm	1	6 mm	7,5 kg	1
26701	1 000 kg	300 mm	3 000 mm	1	6 mm	9 kg	1
26702	2 000 kg	380 mm	3 000 mm	2	6 mm	12 kg	1





WYCIĄGARKA

N.p.	Specyfikacja	
50035	2 t	6
50036	4 t	4



ŁAŃCUCH KRÓTKO-OGNIWOWY



DIN 5685 A Zn

N.p.	size of eye	długość		N.p.	size of eye	długość	
51402	2 x 10 mm	110 m	1	51406	6 x 24 mm	18 m	1
51403	3 x 16 mm	60 m	1	51407	7 x 50 mm	16 m	1
51404	4 x 21 mm	40 m	1	51408	8 x 32 mm	10 m	1
51405	5 x 23 mm	30 m	1	51410	10 x 39 mm	10 m	1



ŁAŃCUCH VICTOR



DIN 5686 Zn

N.p.	Ø materiału	długość		N.p.	Ø materiału	długość	
51430	1,4 mm	150 m	1	51433	2,0 mm	118 m	1
51431	1,6 mm	150 m	1	51435	2,5 mm	70 m	1
51432	1,8 mm	130 m	1	51436	2,8 mm	50 m	1



ŁAŃCUCH DŁUGO-OGNIWOWY

DIN 5685 C Zn

N.p.	size of eye	długość		N.p.	size of eye	długość	
51412	2 x 12 mm	80 m	1	51416	6 x 43 mm	18 m	1
51413	3 x 26 mm	60 m	1	51417	7 x 50 mm	16 m	1
51414	4 x 32 mm	38 m	1	51418	8 x 54 mm	10 m	1
51415	5 x 35 mm	32 m	1	51420	10 x 65 mm	10 m	1



ŁAŃCUCH PLASTIKOWY



N.p.	specyfikacja	
51450	6 mm 25 m czerwono-biały	1



WCIĄGARKA LINOWA

Zn

N.p.	ładowność	długość lana	
26720	300 kg	8 m	1
26705	450 kg	8 m	1
26721	500 kg	8 m	1
26722	800 kg	8 m	1
26706	900 kg	8 m	1
26707	1350 kg	8 m	1



STOJAK NA LINKI

N.p.	specyfikacja	
51196	Promotional stand for chains staffed	10
51197	Promotional stand for ropes staffed	10
51198	Promotional stand for chains	10
51199	Promotional stand for ropes	10



LINA STALOWA OCYNK

Zn

N.p.	długość	
51100	Ø 1 mm 500 m	1
51102	Ø 1,5 mm 500 m	1
51103	Ø 2 mm 200 m	1
51104	Ø 3 mm 200 m	1
51105	Ø 4 mm 100 m	1
51106	Ø 5 mm 75 m	1
51107	Ø 6 mm 75 m	1
51130	Ø 8 mm 75 m	1
51131	Ø 10 mm 50 m	1
51132	Ø 12 mm 50 m	1



LINA STALOWA OCYNK Z PCV

Zn

N.p.	długość	
51108	Ø 2/3 mm 200 m	1
51109	Ø 3/4 mm 100 m	1
51110	Ø 4/5 mm 75 m	1
51111	Ø 5/6 mm 50 m	1



LINA STALOWA NIERDZ.

INOX

N.p.	długość	
51120	Ø 1 mm 300 m	1
51121	Ø 1,2 mm 300 m	1
51122	Ø 1,5 mm 300 m	1
51123	Ø 2 mm 200 m	1
51124	Ø 3 mm 200 m	1
51125	Ø 4 mm 100 m	1
51126	Ø 5 mm 75 m	1
51127	Ø 6 mm 75 m	1





PRĘT GWINTOWANY

PRĘT GWINTOWANY

DIN 975 **Zn**

4.8 klasa wytrzymałości

N.p.	specyfikacja	
55040	M 4 1 m	200
55050	M 5 1 m	150
55060	M 6 1 m	100
55080	M 8 1 m	50
55100	M 10 1 m	20
55120	M 12 1 m	20
55140	M 14 1 m	15
55160	M 16 1 m	15
55180	M 18 1 m	10
55200	M 20 1 m	10
55220	M 22 1 m	5
55240	M 24 1 m	5
55300	M 30 1 m	5

DIN 976 **INOX** **4.8** klasa wytrzymałości

N.p.	specyfikacja	
55315	M 12 1 m	20
55316	M 14 1 m	15
55317	M 16 1 m	15
55318	M 18 1 m	10
55319	M 20 1 m	10

before after



PRĘT GWINTOWANY

DIN 975 **4.8** klasa wytrzymałości

N.p.	specyfikacja	
55051	M 5 1 m	150
55181	M 18 1 m	10
55201	M 20 1 m	10
55221	M 22 1 m	5

FESTA

ŚRODEK DO CZYSZCZENIA KRAWĘDZI

Ø 3 - 19 mm

1/4"

N.p.	Specyfikacja	
16321		5



NAKRĘTKI

DIN 934 **Zn**

4.8 klasa wytrzymałości

N.p.	specyfikacja	
55350	M 4 100 szt.	1
55351	M 5 100 szt.	1
55352	M 6 100 szt.	1
55353	M 8 100 szt.	1
55354	M 10 100 szt.	1
55355	M 12 100 szt.	1
55356	M 14 100 szt.	1
55357	M 16 100 szt.	1
55358	M 18 100 szt.	1
55359	M 20 10 szt.	1
55360	M 22 10 szt.	1
55361	M 24 10 szt.	1
55362	M 30 10 szt.	1



PODKŁADKI

DIN 440R **Zn**



N.p.	specyfikacja	
55331	M 5 100 szt.	1
55332	M 6 100 szt.	1
55333	M 8 100 szt.	1
55334	M 10 100 szt.	1
55335	M 12 100 szt.	1
55336	M 14 100 szt.	1
55337	M 16 100 szt.	1
55339	M 20 10 szt.	1
55340	M 22 10 szt.	1
55341	M 24 10 szt.	1
55342	M 30 10 szt.	1



FESTA

ORGANIZER



N.p.	Specyfikacja	
55650	375 x 290 x 67 mm	1



ŚRUBA DO DREWNA

2000x

N.p.	specyfikacja	
55640	2000 szt.	1



szt.	
350	3,0 x 16 mm
280	3,0 x 20 mm
220	3,0 x 25 mm
250	3,5 x 20 mm
240	3,5 x 25 mm
180	3,5 x 3, mm
280	4,0 x 16 mm
80	4,0 x 30 mm
40	4,0 x 40 mm
30	4,0 x 50 mm
25	5,0 x 50 mm
25	5,0 x 60 mm

ŚRUBA DO DREWNA + KOŁKI

śruba do drewna

szt.	
40	3,5 x 30 mm
25	4,0 x 40 mm
12	5,0 x 50 mm
8	6,0 x 60 mm

kołki

szt.	
40	5 x 25 mm
25	6 x 30 mm
12	8 x 40 mm
8	10 x 50 mm

170x

N.p.	specyfikacja	
55645		1



ŚRUBA DO DREWNA

szt.	
60	3,0 x 12 mm
50	3,0 x 16 mm
40	3,0 x 20 mm
50	3,5 x 20 mm
40	3,5 x 30 mm
25	4,0 x 30 mm
20	4,0 x 40 mm
15	5,0 x 50 mm
10	5,0 x 60 mm

310x

N.p.	specyfikacja	
55642		1





OKULARY OCHRONNE

CE EN
166

N.p. specyfikacja 10

50510



OKULARY OCHRONNE

CE EN
166

N.p. specyfikacja 10

50514



OKULARY OCHRONNE

regulowana długość skroni

CE EN
166

N.p. specyfikacja 12

50511



OKULARY OCHRONNE

CE EN
170

N.p. specyfikacja 12

50512

ciemne



OKULARY OCHRONNE

CE EN
166

N.p. specyfikacja 1

50513



OCHRONNIKI SŁUCHU

CE EN
35227
dB

N.p. specyfikacja 1

50563



OCHRONNIKI SŁUCHU

CE EN
35227
dB

N.p. specyfikacja 1

50564

TARCZA OCHRONNA
TWARZYCE EN
166

N.p. specyfikacja 10

50556

TARCZA OCHRONNA
TWARZYCE
EN 1731

N.p. specyfikacja 10

50562



ZATYCZKI DO USZU

N.p. specyfikacja 100

50560



ZATYCZKI DO USZU

N.p. specyfikacja 100

50559



KASK OCHRONNY CLIMAX

CE EN
397MADE IN
EU

N.p. specyfikacja 30

50550

niebieski

50551

czerwony

50553

biały

50554

żółty



KAMIZELKA ODBŁASKOWA

CE EN
20471

N.p. specyfikacja 100

50570

pomarańczowy

50571

żółty



KŁĘCZNIK NA KÓŁKACH

N.p.	specyfikacja	
37135		1



FESTA
OCHRANIACZE KOLAN

N.p.	specyfikacja	
37145	gel	8



FESTA
OCHRANIACZE KOLAN

N.p.	specyfikacja	
37140	gel	12



FESTA
OCHRANIACZE KOLAN

N.p.	specyfikacja	
37144	gel	12



FESTA
OCHRANIACZE KOLAN

N.p.	specyfikacja	
37143		12



FESTA
OCHRANIACZE KOLAN

N.p.	specyfikacja	
37142	komfort	20



OCHRANIACZE KOLAN

N.p.	specyfikacja	
37139	neopren	10



OCHRANIACZE KOLAN

N.p.	specyfikacja	
37141		6





REKAWICE SKÓRZANE, WZMOCNINE

· Z podszewką w dłoni



N.p.	specyfikacja	
50518	rozmiar 11"	12



REKAWICE SKÓRZANE, WZMOCNINE

· Z podszewką w dłoni



N.p.	specyfikacja	
50519	rozmiar 10,5"	12



REKAWICE SKÓRZANE



N.p.	specyfikacja	
50520	rozmiar 10,5"	12



REKAWICE BAWELNIANE, NAKRAPIANE PVC

N.p.	specyfikacja	
50524	rozmiar 10"	12



REKAWICE BAWELNIANE, PÓKRYTE PVC



N.p.	specyfikacja	
50525	rozmiar 10" - długość 35 cm	12



REKAWICE POLYESTER, NAKRAPIANE PVC

· Nakrapiane PVC

N.p.	specyfikacja	
50526	rozmiar 10"	12



REKAWICE BAWELNIANE, PÓKRYTE LATEXEM



N.p.	specyfikacja	
50522	rozmiar 10"	12



REKAWICE NYLONOWE, PÓKRYTE NITRYLEM



N.p.	specyfikacja	
50533	rozmiar 10"	12



REKAWICE POKRYTE LATEXOWĄ PIANĄ



N.p.	specyfikacja	
50535	rozmiar 8"	12
50536	rozmiar 9"	12
50537	rozmiar 10"	12



REKAWICE POKRYTE NITRY- LOWĄ PIANĄ

· Nakrapiane PVC



N.p.	specyfikacja	
50539	rozmiar 10"	12



REKAWICE AKRYLOWE Z PÓWŁOKĄ LATEKSOWĄ



N.p.	specyfikacja	
50529	rozmiar 10"	12



REKAWICE

N.p.	specyfikacja	
50557	rozmiar 7"	12
50558	rozmiar 8"	12
50549	rozmiar 9"	12



REKAWICE BAWELNIANE, NAKRAPIANE PVC

Nakrapiane PVC

N.p.	specyfikacja	
50531	rozmiar 9"	12



REKAWICE MECHANIK, NYLON- SKÓRA KOZIA

N.p.	specyfikacja	
50541	rozmiar 9"	12
50542	rozmiar 10"	12



REKAWICE MECHANIK, NYLON- SKÓRA SWINSKA

N.p.	specyfikacja	
50544	rozmiar 10"	12



REKAWICE NYLONOWE, PÓWLEKANE POLIURETANEM



N.p.	specyfikacja	
50527	rozmiar 10"	12



REKAWICE SPAWALNICZE



N.p.	specyfikacja	
50540	rozmiar 11"	12



REKAWICE WINYLOWE

przezroczysty, bez proszku



N.p.	specyfikacja	
50532	rozmiar 9"	100



RESPIRATOR



N.p.	specyfikacja	
50500	FFP2 bez zaworka	30



RESPIRATOR



N.p.	specyfikacja	
50503	FFP2 z zaworkiem	20



KOMBINEZONY OCHRONNE Z KAPTUREM

N.p.	specyfikacja	
50585	rozmiar M	1
50586	rozmiar L	1
50587	rozmiar XL	1
50588	rozmiar XXL	1



FARTUCH DO SPAWANIA



N.p.	specyfikacja	
50555	skórzany	1

**FESTO****TORBA NARZĘDZIOWA Z METALOWYM UCHWYTEM**

N.p.	wysokość	długość	głębokość	
37331	280 mm	490 mm	230 mm	2

**FESTO****TORBA NA NARZĘDZIA**

N.p.	szerokość	wysokość	głębokość	
37332	480 mm	290 mm	250 mm	1

FESTO**TORBA NA NARZĘDZIA**

N.p.	szerokość	wysokość	głębokość	
37330	610 mm	400 mm	270 mm	5

**FESTO****KIESZEŃ NA NARZĘDZIA**

wzmocnione kieszenie



N.p.	specyfikacja	
37325		10

**FESTO****KIESZEŃ NA NARZĘDZIA**

wzmocnione kieszenie



N.p.	specyfikacja	
37326		12

**FESTO****PAS NARZĘDZIOWY**

N.p.	specyfikacja	
37328	145 cm	20



FESTA

PAS NARZĘDZIOWY Z KIESZENIAMI

· 14 kieszeni + oko



N.p.	długość	szerokość	
37311	120 cm	6 cm	1



FESTA

PAS NARZĘDZIOWY



N.p.	długość	szerokość	
37310	120 cm	6 cm	1



FESTA

KIESZEŃ NA NARZĘDZIA

· 8 kieszeni



N.p.	szerokość	wysokość	
37320	300 mm	250 mm	1



FESTA

KIESZEŃ NA NARZĘDZIA

· 4 kieszeni



N.p.	szerokość	wysokość	
37321	350 mm	300 mm	1



FESTA

KAMIZELKA ROBOCZA

N.p.	specyfikacja	
37350		20



FESTA

PAS NARZĘDZIOWY – SKÓRA



N.p.	specyfikacja	
37302	6 kieszeni	50
37303	11 kieszeni	25



PAS NARZĘDZIOWY – SKÓRA



N.p.	specyfikacja	
37300	6 kieszeni	50
37301	11 kieszeni	25



FESTA



SKÓRZANA TORBA PROFI



N.p.	wysokość	długość	głębokość	
37342	270 mm	430 mm	180 mm	1



SKÓRZANA TORBA ELEKTRYCZNA



N.p.	wysokość	długość	głębokość	
37341	260 mm	430 mm	200 mm	1



SKÓRZANA TORBA ZE WZMOCNIONYM DNEM



N.p.	wysokość	długość	głębokość	
37340	240 mm	430 mm	150 mm	1



TORBA RZEMIEŚNICZA NA RAMIĘ Z PASKIEM



N.p.	wysokość	długość	głębokość	
37344	250 mm	300 mm	130 mm	1



TORBA ZE WZMOCNIONYM DNEM

N.p.	wysokość	długość	głębokość	
37343	240 mm	430 mm	150 mm	1



TORBA DLA ELEKTRYKÓW

N.p.	wysokość	długość	głębokość	
37345	270 mm	430 mm	180 mm	1

SPRZĄCZKA "O"



N.p.	specyfikacja
37308	20



SPRZĄCZKA "U"



N.p.	specyfikacja
37309	20





FESTA

WKŁADKA BĘBENKOWA
CYLINDRYCZNA



N.p.	specyfikacja	
23001	65 mm · 175 g	10



WKŁADKA BĘBENKOWA
NIKIEL POWLEKANA



N.p.	specyfikacja	
23000	65 mm · 75 g	15



FESTA

KLÓDKA ŻELIWNA



N.p.	specyfikacja	
23261	25 mm	6
23262	32 mm	12
23263	38 mm	6
23264	45 mm	6
23265	52 mm	12
23266	63 mm	6



FESTA

KLÓDKA MOSIĘŻNA
HARTOWANA



N.p.	specyfikacja	
23125	25 mm	12
23130	30 mm	12
23135	35 mm	12
23140	40 mm	12
23150	50 mm	12
23160	60 mm	12



FESTA

KLÓDKA MOSIĘŻNA,
POWLEKANA PCV



N.p.	specyfikacja	
23310	30 mm	10
23311	40 mm	10
23312	50 mm	6



FESTA

KLÓDKA ŻELIWNA
WYDŁUŻONA



N.p.	specyfikacja	
23211	25 mm	12
23212	32 mm	12
23213	38 mm	6
23214	45 mm	6
23215	52 mm	6



FESTA

KLÓDKA MOSIĘŻNA
TRZPIENIOWA



N.p.	specyfikacja	
23274	60 mm	6
23275	70 mm	12



KLÓDKA ŻELIWNA



N.p.	specyfikacja	
23220	25 mm	6
23225	30 mm	6
23232	32 mm	6
23240	40 mm	6
23250	50 mm	6
23260	60 mm	6



KLÓDKA MOSIĘŻNA



N.p.	specyfikacja	
23020	20 mm	12
23025	25 mm	12
23030	30 mm	12
23035	35 mm	12
23040	40 mm	12
23050	50 mm	12
23060	60 mm	12





KLÓDKA MOSIĘŻNA WYDŁUŻONA



N.p.	specyfikacja	
23070	40 mm	12

KLÓDKA Z OKRĄGLYM KABŁAKIEM



N.p.	specyfikacja	
23010	50 mm	6



KLÓDKA WODO- ODPORN



N.p.	specyfikacja	
23005	40 mm	6
23006	50 mm	6



FESTA

LINKA PRZECIWKRADZIEŻOWA



N.p.	specyfikacja	
23288	120 cm x Ø 10 mm	1



FESTA

LINKA PRZECIWKRADZIEŻOWA



N.p.	specyfikacja	
23287	65 cm x Ø 10 mm	1



FESTA

LINKA PRZECIWKRADZIEŻOWA



N.p.	specyfikacja	
23290	120 cm x Ø 8 mm	1
23291	150 cm x Ø 8 mm	1
23292	180 cm x Ø 8 mm	1



LINKA PRZECI- WKRADZIEŻOWA



N.p.	specyfikacja	
23282	55 cm x Ø 8 mm	50
23284	65 cm x Ø 8 mm	50



ZAMKNIĘCIE Z KODEM



N.p.	specyfikacja	
23281		20





FESTA

**SEJF
Z ZAMKIEM ELEKTRONICZNYM**



- Rodzaj zamka: elektroniczny, mechaniczny
- Klucz bezpieczeństwa
- Wymiary 350x250x250mm
- Waga 10kg



N.p.	specyfikacja	
23270		1

FESTA

**IDENTYFIKATORY
DO KLUCZY**

100x



N.p.	specyfikacja	
23391		50

**IDENTYFIKATORY
DO KLUCZY**

100x



N.p.	specyfikacja	
23390		1

KASETA NA PIENIĄDZE



N.p.	szerokość	głębokość	wysokość	
70120	125 mm	95 mm	60 mm	1

ZASUWA PRZEGUBOWA

N.p.	specyfikacja	
51514	100 mm	25
51515	120 mm	25
51516	140 mm	25
51517	160 mm	25



ZASUWA

N.p.	specyfikacja	
51510	100 mm	12
51511	120 mm	12
51512	140 mm	12
51513	160 mm	12



SKRZYNIKA NA KLUCZE



N.p.	specyfikacja	
70140	250 x 180 x 80 mm - na 48 kluczy	12
70141	300 x 230 x 90 mm - na 90 kluczy	8

KASETA NA PIENIĄDZE



N.p.	szerokość	głębokość	wysokość	
70122	200 mm	160 mm	90 mm	20

KASETA NA PIENIĄDZE



N.p.	szerokość	głębokość	wysokość	
70123	250 mm	180 mm	90 mm	16



KASETA NA PIENIĄDZE



N.p.	szerokość	głębokość	wysokość	
70124	300 mm	240 mm	90 mm	10



KASETA NA PIENIĄDZE



N.p.	szerokość	głębokość	wysokość	
70125	370 mm	280 mm	90 mm	8



SKRZYNKA POCZTOWA



N.p.	kolor	szerokość	wysokość	głębokość	
70101	biała	290 mm	360 mm	105 mm	5
70100	brązowa	290 mm	360 mm	105 mm	5



SKRZYNKA POCZTOWA



N.p.	kolor	szerokość	wysokość	głębokość	
70102	biała	310 mm	260 mm	90 mm	10
70103	brązowa	310 mm	260 mm	90 mm	10



SKRZYNKA POCZTOWA



N.p.	kolor	szerokość	wysokość	głębokość	
70105	brązowa	310 mm	360 mm	90 mm	5



SKRZYNKA POCZTOWA



N.p.	kolor	szerokość	głębokość	wysokość	
70108	biała	370 mm	134 mm	364 mm	5



SKRZYNKA POCZTOWA



N.p.	szerokość	głębokość	wysokość		
70107	nierdz.	360 mm	100 mm	520 mm	6



SKRZYNKA POCZTOWA



N.p.	szerokość	głębokość	wysokość		
70106	nierdz.	360 mm	100 mm	360 mm	5



SKRZYNKA POCZTOWA



N.p.	szerokość	głębokość	wysokość		
70109	nierdz.	310 mm	90 mm	260 mm	6



SKRZYNKA POCZTOWA



N.p.	szerokość	głębokość	wysokość		
70110	nierdz.	310 mm	90 mm	360 mm	6

WAGA SPRĘŻYNOWA

N.p.	maximalni ładowność		
24260	50 kg	10	



WAGA SPRĘŻYNOWA

N.p.	maximalni ładowność	
24212	12,5 kg	48
24225	25 kg	6
24250	50 kg	6
24255	100 kg	6
24258	150 kg	6



PINCETA Z OŚWIETLENIEM LED

N.p.	specyfikacja	
50005	95 mm	8



ZESTAW PINCET NIERZD.

N.p.	specyfikacja	
50004	2x	1

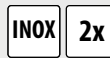

ŁAPKA NA MYSZY

N.p.	specyfikacja	
70221	90 x 45 mm drewniany	1



ŁAPKA NA MYSZY

N.p.	specyfikacja	
70220	97 x 47 mm plastikowy	48



SPRĘŻYNA DO KANALIZACJI

możliwość użycia z wiertarką

N.p.	długość	Ø	
50014	6 m	6 mm	6

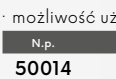

SPRĘŻYNA DO KANALIZACJI

N.p.	długość	
50010	3 m	10
50011	5 m	5
50012	10 m	3
50013	15 m	4



SPRĘŻYNA DO KANALIZACJI

N.p.	długość	Ø	
50009	3 m	5 mm	40



POMPKA DO PRZETYKANIA RUR

N.p.	długość	Ø	
50015	385 mm	65 mm	30

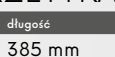
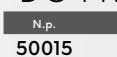

SPRĘŻYNA DLA ELEKTRYKÓW

N.p.	długość	Ø	
51181	8 m	5 mm	25
51182	10 m	5 mm	25

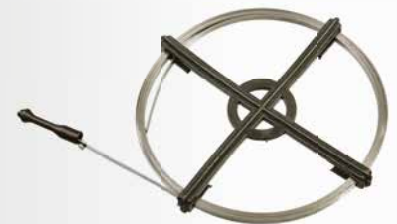
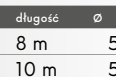
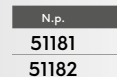



244

KIELNIE, NOŻE DO KITÓW
I SKROBACZKI

250

CZERPAK MURARSKI



254

SKROBAK



255

PACA I SZLIFOWANIE SIATKI



257

PACA ZA GIPS



261

MIESZADŁO



266

BETONIARKI BUDOWLANE



269

ZSYP NA GRUZ



269

TACZKI

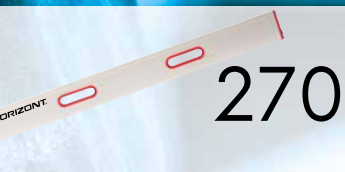

270

ŁATA HORIZONT



272

PRZECINARKA KOSTKI
BRUKOWEJ

274

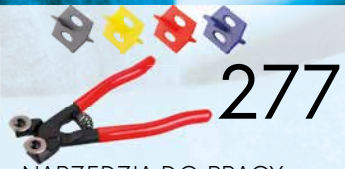
MASZYNKA DO GLAZURY
SUPER PRO

277

NARZĘDZIA DO PRACY
Z PŁYTKAMI

280

AKCESORIA DO
POZIOMOWANIA

286

PRZECINARKA DO
STYROPIANU

292

NARZĘDZIA DO PŁYT
GIP-SOWO-KARTONOWYCH

294

PALNIK PB



296

KASTRY NA ZAPRAWĘ



297

WYCISKACZ DO TUB



299

WYCISKACZ PU



300

PĘDZLE I WĄŁKI
DO MAŁOWANIA

305

PLANDEKA



306

DRABINA



307

PODPORY SZALUNKOWA,
DRZWICZKI DO KOMINKA

NARZĘDZIA
BUDOWLANE

242 - 307



**FESTA**

PACA
NIERDZEWNA
280 X 130 MM

· gumowa rekojesc



N.p.	specyfikacja	
31140	gładka	10

FESTA

PACA
NIERDZEWNA
280 X 130 MM

· gumowa rekojesc



N.p.	specyfikacja	
31148	gładka	10

FESTA

PACA
NIERDZEWNA
280 X 130 MM
ZĘBATA

· gumowa rekojesc



N.p.	specyfikacja	
31146	Ø 16	10

FESTA

PACA
NIERDZEWNA
280 X 130 MM
ZĘBATA

· gumowa rekojesc



N.p.	specyfikacja	
31141	e 4	10
31142	e 6	10
31143	e 8	10

N.p.	specyfikacja	
31144	e 10	10
31145	e 12	10

FESTA

PACA
NIERDZEWNA
280 X 130 MM
ZĘBATA



N.p.	specyfikacja	
31101	e 4	10
31111	e 6	10
31121	e 8	10

N.p.	specyfikacja	
31131	e 10	10
31132	e 12	10

FESTA

PACA
NIERDZEWNA
280 X 130 MM



N.p.	specyfikacja	
31091	gładka	10

FESTA

PACA
NIERDZEWNA
280 X 130 MM



N.p.	specyfikacja	
31011	gładka	10

FESTA

PACA
NIERDZEWNA
280 X 130 MM
ZĘBATA



N.p.	specyfikacja		N.p.	specyfikacja	
31021	e 4	10	31051	e 10	10
31031	e 6	10	31053	e 12	10
31041	e 8	10			

PACA
NIERDZEWNA
270 X 125 MM



N.p.	specyfikacja	
31005	gładka	25

PACA
NIERDZEWNA
270 X 125 MM
ZĘBATA



N.p.	specyfikacja		N.p.	specyfikacja	
31006	e 4	24	31008	e 8	24
31007	e 6	24	31009	e 10	24

FESTA

PACA
NIERDZEWNA
360 X 130 MM



N.p.	specyfikacja	
31151	gładka	10

FESTA

PACA
NIERDZEWNA
360 X 130 MM



N.p.	specyfikacja	
31150	gładka	10

FESTA

PACA
NIERDZEWNA
480 X 130 MM



N.p.	specyfikacja	
31082	gładka	10

FESTA

PACA
NIERDZEWNA
680 X 130 MM



N.p.	specyfikacja	
31155	gładka	10

FESTA

PACA NIERDZEWNA
ZĘBATA
500 X 130 MM



N.p.	specyfikacja	
31052	e 4	10
31061	e 6	10
31062	e 8	10
31071	e 10	10
31072	e 12	10

FESTA

PACA
NIERDZEWNA
500 X 130 MM



N.p.	specyfikacja	
31081	gładka	10



FESTA

KIELNIA NIERDZEWNA

INOX · gumowa rekojesc

N.p.	specyfikacja	
31232	120 mm	10
31233	140 mm	10

**FESTA**

KIELNIA NIERDZEWNA

INOX

N.p.	specyfikacja	
31220	120 x 80 mm	10
31221	140 x 80 mm	10

**FESTA**

KIELNIA ZAOKRĄGLONA NIERDZEWNA

INOX · gumowa rekojesc

N.p.	specyfikacja	
31334	160 x 100 mm	10

**FESTA**

KIELNIA ZAOKRĄGLONA NIERDZEWNA

INOX

N.p.	specyfikacja	
31343	160 x 100 mm	10

**FESTA**

KIELNIA SZTUKATORSKA NIERDZEWNA

INOX · gumowa rekojesc

N.p.	specyfikacja	
31360	40 mm	10
31380	60 mm	10
31390	80 mm	10

**FESTA**

KIELNIA SZTUKATORSKA NIERDZEWNA

INOX

N.p.	specyfikacja	
31362	40 mm	10
31382	60 mm	10

**FESTA**

KIELNIA SZTUKATORSKA NIERDZEWNA

INOX · gumowa rekojesc

N.p.	specyfikacja	
31330	140 x 50 mm	10
31340	160 x 60 mm	10

**FESTA**

KIELNIA SZTUKATORSKA NIERDZEWNA

INOX

N.p.	specyfikacja	
31332	140 x 50 mm	10
31341	160 x 60 mm	10

**FESTA**

KIELNIA DO NAROŻNIKÓW WEW

INOX · gumowa rekojesc

N.p.	specyfikacja	
31280	80 x 60 x 60 mm	10

**FESTA**

KIELNIA DO NAROŻNIKÓW WEW

INOX

N.p.	specyfikacja	
31281	80 x 60 x 60 mm	10

**FESTA**

KIELNIA DO NAROŻNIKÓW ZEWN

INOX · gumowa rekojesc

N.p.	specyfikacja	
31270	80 x 60 x 60 mm	10

**FESTA**

KIELNIA DO NAROŻNIKÓW ZEWN

INOX

N.p.	specyfikacja	
31271	80 x 60 x 60 mm	10



FESTA

**KIELNIA DEKARSKA
NIERDZEWNA**

INOX · gumowa rekojesc

N.p.	specyfikacja	
31320	140 x 75 mm	10



FESTA

**KIELNIA DEKARSKA
NIERDZEWNA**

INOX

N.p.	specyfikacja	
31322	140 x 75 mm	10



FESTA

**KIELNIA
ZĘBATA DO
PÓROBETONU**

INOX

N.p.	specyfikacja	
31218	180 mm e 6	12



FESTA

**SZPACHLA
NIERDZEWNA**

· gumowa rekojesc

INOX

N.p.	specyfikacja	
31510	40 mm	10
31511	60 mm	10
31512	80 mm	10



FESTA

**SKROBAK
NIERDZEWNY**

· gumowa rekojesc
· wzmocnione ostrze

INOX

N.p.	specyfikacja	
32173	75 mm	10



FESTA

**SKROBAK
Z GWINTEM NA KIJ**

· trzonek 52010
· wzmocnione ostrze

INOX

N.p.	specyfikacja	
32170	100 mm	12



FESTA

**SZPACHLA
Z BITEM**

· gumowa rekojesc

INOX

N.p.	specyfikacja	
31455	150 mm	12
31456	200 mm	12

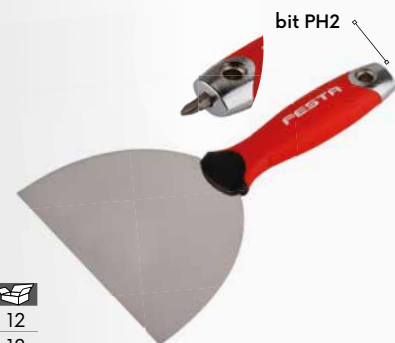

FESTA

**SZPACHLA
NIERDZEWNA**

INOX

N.p.	specyfikacja	
31517		10



FESTA

**SZPACHLA
NIERDZEWNA**

· gumowa rekojesc

INOX

N.p.	specyfikacja	
31505	200 mm	5
31506	250 mm	5
31507	300 mm	5



**FESTA****SKROBAK NIERDZEWNY**

wzmocnione ostrze

INOX

N.p.	szerokość	długość	
32174	100 mm	500 mm	1

FESTA**SZPACHLA NIERDZEWNA****INOX**

R.s.	leírás	
31461	40 mm	12
31471	60 mm	12
31481	80 mm	12
31491	100 mm	12
31467	120 mm	12
31468	140 mm	12

**FESTA****SZPACHELKA NIERDZEWNA****INOX**

N.p.	specyfikacja	
31498	150 mm	12
31499	200 mm	12
31500	100 mm	12

**SZPACHELKA NIERDZEWNA****INOX**

MADE IN EU

N.p.	specyfikacja	
31493	40 mm	20
31494	60 mm	20
31495	80 mm	20
31496	100 mm	20

**SZPACHELKA STALOWA**

R.s.	leírás	
32176	30 mm	12
32186	40 mm	12
32196	50 mm	12
32206	60 mm	12
32216	80 mm	12
32226	100 mm	12
32234	125 mm	12

**ZESTAW SZPACHELEK STALOWYCH****3x**

N.p.	specyfikacja	
32240	30, 50, 80 mm	10

**FESTA****SZPACHELKA STALOWA**

N.p.	specyfikacja		N.p.	specyfikacja	
32161	30 mm	10	32171	90 mm	10
32162	40 mm	10	32166	100 mm	10
32163	50 mm	10	32172	110 mm	10
32164	60 mm	10	32167	120 mm	10
32169	70 mm	10	32168	140 mm	10
32165	80 mm	10			

**WAŁEK DO NAKŁADANIA TYNKU**

- uchwyt 180mm - 52630
- uchwyt 250mm - 52625
- rączka długa 52010, 52011, 52012, 52020, 52030



N.p.	Specyfikacja			
52611	250 mm	Ø 8 mm	Ø 48 mm	50
52612	180 mm	Ø 8 mm	Ø 48 mm	10

FESTA

SZPACHLA DO USZCZELNIANIA CAŁEJ POWIERZCHNI

INOX

R.s.	leírás	
31555	35 cm	1
31556	45 cm	1
31557	60 cm	1
31558	80 cm	1
31559	100 cm	1



FESTA

TELESKOPOWA RĄCZKA

gwint do 31610, 34203

N.p.	Specyfikacja	
52011	88 - 140 cm	1

FESTA

UCHWYT NA SZPATULKĘ DO USZCZELNIENIA NA CAŁEJ POWIERZCHNI

dla 31555 - 31559
uchwyt 52010, 52011, 52012, 52020, 52030

N.p.	Specyfikacja	
31610		1



SZPACHLA STAL NIERDZEWNA ZE WZMOCNIENIEM

INOX

MADE IN EU

N.p.	specyfikacja	
31520	400 mm	1
31521	500 mm	
31522	600 mm	



uchwyt 61254



31523



31524

KIELNIA STAL NIERDZEWNA ZE WZMOCNIENIEM-AKCESORIA

MADE IN EU

N.p.	specyfikacja	
31523	Uchwyt ALU	1
31524	plastikowy uchwyt	1

SZPACHLA DO FASAD NIERDZEWNA

INOX

N.p.	specyfikacja	
31552	400 mm	10
31553	600 mm	10



SZPACHLA DO SZTABLATURY NIERDZEWNA

INOX

MADE IN EU

N.p.	specyfikacja	
31541	250 mm	1
31551	250 mm úzka	1

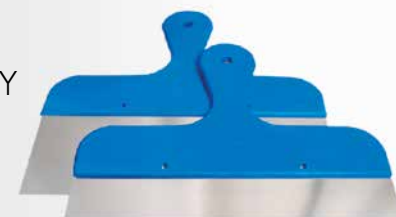

PACA STALOWA

N.p.	specyfikacja	
32062	280 x 160 mm	10
32060	500 x 140 mm	5

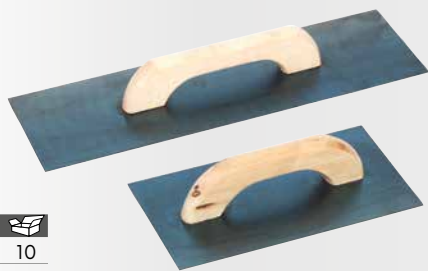

PACA STALOWA SKOŚNA

N.p.	specyfikacja	
32064	500 x 90 mm	5
32066	550 x 140 mm	5



KIELNIA STALOWA SZLIFOWANA

N.p.	specyfikacja	
32015	160 x 130 mm	10
32014	180 x 130 mm	10
32016	200 x 140 mm	10



KIELNIA STALOWA

N.p.	specyfikacja	
32001	160 x 110 mm	10
32002	160 x 130 mm	10
32003	180 x 130 mm	10
32013	200 x 140 mm	10



KIELNIA STALOWA

N.p.	specyfikacja	
32018	160 x 110 mm	10



KIELNIA SZTUKATORSKA

N.p.	specyfikacja	
32024	140 x 80 mm	12



KIELNIA ZAOKRĄGLONA

N.p.	specyfikacja	
32020	140 x 65 mm	12
32021	140 x 40 mm	12



KIELNIA DEKARSKA

N.p.	specyfikacja	
32026	140 x 85 mm	12



FESTA

CZERPAK MURARSKI Z RĄCZKĄ NIERDZEWNY

INOX

N.p.	specyfikacja	
32285	Ø 180 mm	1



FESTA

CZERPAK MURARSKI Z RĄCZKĄ

Zn

N.p.	specyfikacja	
32265	Ø 180 mm	10



FESTA

CZERPAK MURARSKI Z RĄCZKĄ

N.p.	specyfikacja	
32273	Ø 160 mm	10
32283	Ø 180 mm	10
32293	Ø 215 mm	10



CZERPAK MURARSKI PLASTIKOWY



N.p.	specyfikacja	
32270	Ø 160 mm	1



CZERPAK MURARSKI

trzonek 61215

N.p.	specyfikacja	
32302	Ø 180 mm	1
32313	Ø 215 mm	1
32301	Ø 235 mm	1



CZERPAK MURARSKI ŁOPATKA

trzonek 61200, 61201

N.p.	specyfikacja	
32268	Ø 215 mm	1
32269	Ø 235 mm	1
32296	Ø 215 mm	1



ZDZIERAK DO BETONU Z UCHWYTEM

N.p.	specyfikacja	
60100	zdzierak do betonu 295 x 150 mm	24
61169	zdzierak do betonu z uchwytem 160 cm	3
61218	uchwytem 160 cm	5



CZERPAK MURARSKI Z UCHWYTEM

MOQ 3

N.p.	specyfikacja	
32295	Ø 180 mm długość uchwyt 160 cm	3
32297	Ø 215 mm długość uchwyt 160 cm	3
32298	Ø 235 mm długość uchwyt 160 cm	3



BRUZDOWNIK DO YTONGA

N.p.	specyfikacja	
32037	600 mm	1



PRZYRZĄD DO CIĘCIA KĄTOWY - YTONG

N.p.	specyfikacja	
32038	270 x 270 x 270 mm	1



KIELNIA DO BETONU KOMÓRKOWEGO

N.p.	specyfikacja	
32089	150 mm	1



FESTA PRZECINAK PŁASKI

CrV	N.p.	specyfikacja	szerokość	
	19406	300 mm	25 mm	5
19407	400 mm	30 mm	5	



FESTA PUNKTAK

CrV	N.p.	specyfikacja	
	19408	250 mm	5
19409	350 mm	5	



FESTA PRZECINAK PŁASKI

CrV	N.p.	specyfikacja	szerokość	
	19460	300 mm	25 mm	5
19470	400 mm	30 mm	5	



PUNKTAK

N.p.	specyfikacja	
19400	250 mm	5
19403	350 mm	6



PRZECINAK PŁASKI

N.p.	specyfikacja	szerokość	
19401	250 mm	19 mm	6
19404	350 mm	22 mm	6



PRZECINAK PŁASKI

N.p.	specyfikacja	szerokość	
19402	250 mm	50 mm	2
19405	350 mm	50 mm	6



NEW



FESTA

SKROBAK MALARSKI
NIERDZEWNY

INOX

N.p. specyfikacja
31519 75 mm

10

SKROBAK MALARSKI
NIERDZEWNY

INOX

N.p. specyfikacja
31497 63 x 195 mm

12



FESTA

NÓŻ DO TAPET

INOX

N.p. specyfikacja
31503 150 mm

12



SKROBAK MALARSKI

MADE IN EU

N.p. specyfikacja

31501 100 mm

30

31502 zapasowe ostrze

1

SZPACHLA DO PŁYT
GIPSOWO - KARTONOWYCH

PLASTIC

N.p. specyfikacja

34308 50 mm

20

34307 80 mm

12

34306 100 mm

10

34305 150 mm

12



PACA DO SIATKI ŚCIERNEJ

N.p. specyfikacja

34301 230 x 105 mm

1

34304 235 x 80 mm

1



FESTA

PACA DO SIATKI ŚCIERNEJ

N.p. specyfikacja

34200 210 x 115 mm

30

34201 240 x 105 mm

50

34202 240 x 80 mm

50

UCHWYT DO SIATKI
ŚCIERNEJ PRZEGUBOWY

trzonek 52030

ALU

N.p. specyfikacja

34203 230 x 80 mm aluminium

1

52030 tyczka teleskopowa

12

SZLIFOWANIE
SIATKI

10x

N.p. specyfikacja

34271 115 x 290 mm hr.120

80

34272 115 x 290 mm hr.100

80

34273 115 x 290 mm hr.80

80

34274 93 x 290 mm hr.120

80

34275 93 x 290 mm hr.100

80

34276 93 x 290 mm hr.80

80

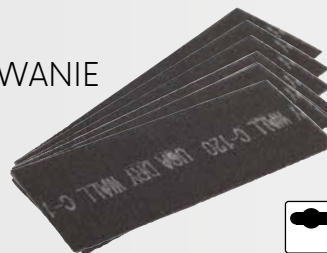
SZLIFOWANIE
SIATKI

3x

N.p. specyfikacja

34280 115 x 290 mm hr.120

20

34281 115 x 290 mm hr.100

20

34282 115 x 290 mm hr.80

20

34283 93 x 290 mm hr.120

20

34284 93 x 290 mm hr.100

20

34285 93 x 290 mm hr.80

20



FESTA

SZPACHLE JAPOŃSKIE

4x

N.p.	specyfikacja	
31452	nierdz. 50, 80, 100, 120 mm	10
31453	stal 50, 80, 100, 120 mm	10

FESTA

SZPACHLE JAPOŃSKIE, PLASTIK

4x

N.p.	specyfikacja	
31454	50, 80, 100, 120 mm	12

SZPACHLA STALOWA

N.p.	specyfikacja	
31601	180 mm - płaska	1
31602	180mm A1	1
31603	180mm A2	1
31641	180 mm - e4	1

SZPACHLA STALOWA

N.p.	specyfikacja	
31651	250 mm - płaska	1
31655	250 mm - e4	1

SZPACHLA PLASTIKOWA

N.p.	specyfikacja	
37101	125 x 85 mm	100
37111	170 x 115 mm	100

SZPACHLA PLASTIKOWA

N.p.	specyfikacja	
37051	płaska	1
37031	zqb - 4 x 6 mm	1
37041	zqb - 6 x 6 mm	1

KIELNIA DO SPOIN

N.p.	specyfikacja	
32022	140 x 80 mm	12
32023	125 x 40 mm	12

KIELNIA DO FUGOWANIA JEDNOSTRONNA

N.p.	specyfikacja	
32040	10 mm	20
32041	12 mm	20
32042	15 mm	20
32043	18 mm	20
32044	20 mm	20

KIELNIA DO FUGOWANIA DWUSTRONNA

N.p.	specyfikacja	
32050	10 12 mm	50
32051	10 15 mm	50
32052	10 18 mm	50
32053	15 20 mm	50

FESTA

ZDZIERAK

· topol

N.p. specyfikacja
32317 450 x 95 mmMOQ
2**FESTA**ZDZIERAK YTONG
DROBNY ZĄB

· topol

N.p. specyfikacja
32312 450 x 95 mmMOQ
2**FESTA**

ZDZIERAK

· topol

N.p. specyfikacja
32337 260 x 95 mmMOQ
2**FESTA**ZDZIERAK YTONG
DROBNY ZĄB

· topol

N.p. specyfikacja
32338 260 x 95 mmMOQ
2**FESTA**

ZDZIERAK

· topol

N.p. specyfikacja
32327 230 x 145 mmMOQ
2

ZDZIERAK

MADE IN
EUN.p. Specyfikacja
32332 450 x 95 mmMOQ
2

ZDZIERAK

MADE IN
EUN.p. Specyfikacja
32333 230 x 145 mmMOQ
2**FESTA**TARKA
DO STYROPIANUMADE IN
EUN.p. specyfikacja
32314 400 x 180 mmMOQ
2**FESTA**TARKA
DO STYROPIANUMADE IN
EUN.p. specyfikacja
32329 270 x 130 mmMOQ
2TARKA
DO STYROPIANUMADE IN
EUN.p. specyfikacja
33168 380 x 160 mmMOQ
2**FESTA**TARKA
DO STYROPIANUN.p. specyfikacja
32320 400 x 180 mmMOQ
2

TARKA DO STYROPIANU



N.p.	specyfikacja	
32311	400 x 180 mm	2

FESTA

PACA DO STYROPIANU



N.p.	specyfikacja	
32318	400 x 180 mm	2
32319	500 x 250 mm	2
32321	400 x 180 mm P 16 papier ścierny	10
32322	500 x 250 mm P 16 papier ścierny	10

FESTA

PACA SZLIFIERSKA DO STYROPIANU PLASTIK



N.p.	specyfikacja	
32324	270 x 130 mm P 16	2
32323	270 x 130 mm P 16 papier ścierny	10

FESTA

PACA PLASTIKOWA Z TARKĄ



N.p.	specyfikacja	
32330	400 x 180 mm	2
32331	270 x 130 mm	2

ZDZIERAK DO WEŁNY KAMIENNEJ

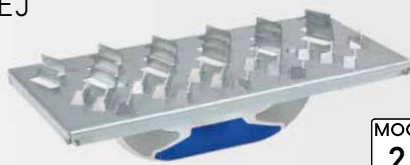

N.p.	specyfikacja	
32328	285 x 145 mm	10

FESTA

SKROBAK



N.p.	specyfikacja	
32325	225 x 105 mm	2

ZDZIERAK KRATKOWY

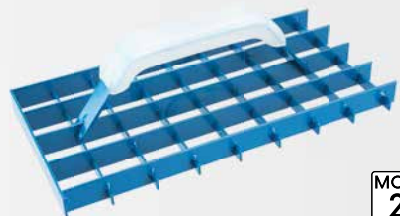

N.p.	specyfikacja	
32316	280 x 150 mm	20



ZDZIERAK KRATKOWY

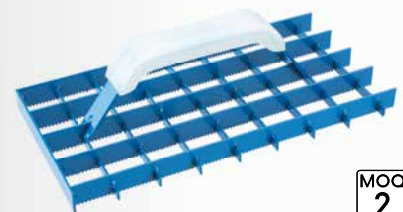

N.p.	specyfikacja	
32335	290 x 145 mm	2

ZDZIERAK ALUMINIOWY

· 8 ostrzami



N.p.	specyfikacja	
32326	450 x 90 mm	20

ZDZIERAK

· 6 ostrzami



N.p.	specyfikacja	
32315	270 x 90 mm	30

FESTA

PACA PLASTIKOWA



N.p.	specyfikacja	
34027	400 x 180 mm	20

PACA PLASTIKOWA

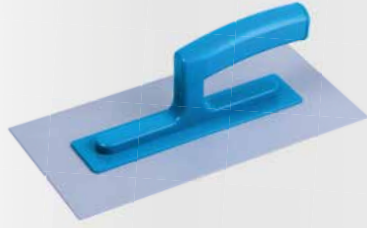

N.p.	specyfikacja	
34028	400 x 180 mm	20

FESTA**PACA
PLASTIKOWA
ABS**

N.p.	specyfikacja	
34041	280 x 140 - 2 mm	10
34051	280 x 140 - 3 mm	10
34053	280 x 140 - 3 mm zqb - e6	10

FESTA**PACA
PLASTIKOWA**

Č.p.	specifikace	
30003	270 x 125 mm	28
30004	235 x 115 mm	35
30005	210 x 115 mm	38
30007	210 x 60 mm	44

FESTA**PACA
DREWNIANA**

drewno lipowe



N.p.	specyfikacja	
34005	400 x 145 mm	40
34007	290 x 145 mm	20

**PACA
DREWNIANA**

drewno topoli



N.p.	specyfikacja	
34006	400 x 145 mm	40

**PACE
POLIURETANOWE
NIEMCY**

N.p.	specyfikacja		N.p.	specyfikacja	
34122	120 x 240 mm	50	34154	220 x 420 mm	15
34132	140 x 280 mm	40	34155	240 x 480 mm	15
34142	180 x 320 mm	25	34156	280 x 500 mm	10
34152	200 x 360 mm	20	34157	330 x 330 mm	5
34121	80 x 260 mm úkosne	50	34158	120 x 800 mm	5
34153	100 x 400 mm	30	34159	120 x 1000 mm	5
			34160	120 x 1200 mm	5

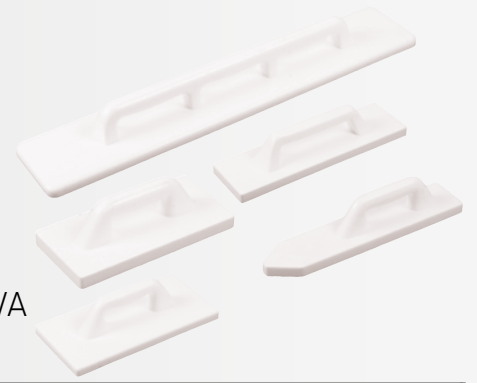
**PACA
STYROPIANOWA**

N.p.	specyfikacja	
34101	80 x 350 mm úkosne	10
34061	130 x 270 mm	10
34111	170 x 320 mm	10
34071	130 x 450 mm	10
34081	140 x 750 mm	10
34091	140 x 900 mm	5

**PACE
POLIURETANOWE**

N.p.	specyfikacja	
34115	140 x 280 mm	36
34116	180 x 320 mm	36
34117	200 x 360 mm	24

**ZDZIERAK
DO POSADZEK**

N.p.	specyfikacja	
15889	980 x 380 mm trzonek Ø 32 mm	1

GUMOWY ŚCIĄGACZ DO WODY

N.p.	specyfikacja	
15886	450 mm trzonek Ø 23 mm	48
15887	600 mm trzonek Ø 23 mm	48
15888	750 mm trzonek Ø 23 mm	32

**ZDZIERAK
DO POSADZEK**

N.p.	specyfikacja	
15885	100 x 800 mm trzonek Ø 32 mm	1

MATERIAŁ POWIERZCHNIA	BETON		TYNK			KLEJE I FUGI	KLEJE DO STOSOWANIA NA ZEMNĄTRZ	ZASTOSOWANIE
	SZORSTKI	WYLEWKI	TRADYCYJNE	LEKKI TYNK (WNĘTRZA)	YTONG			
CZARNY FELC (BRAZOWY, SZARY)				••••		••		Gradowanie lekkich tynków, zastosowanie dla większ. zych ziaren tynku
BIAŁY FILC				••••	••••	••••		Gradowanie lekkich tynków, zastosowanie dla mniejszych ziaren tynku
BIAŁA PIANKA				••••	••••	••••		Usuwanie nadwyżki materiału, dla lżejszego stiuku (mieszanki gipsowej)
SZORSTKI POLIURETAN				••••	••••	••••		Usuwanie nadwyżki materiału, dla cięższego stiuku (mieszanki gipsowej)
NACINANY POLIURETAN				••••	••••	••••		Usuwanie nadwyżki materiału, dzięki zastosowaniu rastra otrzymujemy lepsze efekty dla nieobrobionego stiuku (mieszanki gipsowej).
„MORSKA” GĄBKA					•••		••••	Czyszczenie materiałów, usuwanie nadwyżki materiału.
GĄBKA					•		••••	Czyszczenie materiałów, usuwanie nadwyżki materiału.
GĄBKA				••	••••	••	••••	Czyszczenie materiałów, wygładzanie tynków gipsowych
MIKRO-GUMA							••••	Wypełnianie fug
PIANKA GUMOWA							••••	Wypełnianie fug
MIRELON		••••	•••					Wyrównanie betonu
DUREN				••••	••	••••		Wykończanie tynków gipsowych
DREWNO	••••	••••	••••					Wyrównanie betonu
STAL	••	••••		••		••••	••	Wygładzanie betonu w niedostępnych miejscach
POLISTYREN	•••	••••	•••	••		••		Wyrównanie betonu
POLIURETAN	••••	••••	••••					Wyrównanie betonu
ABS		••		••••	••••	••••	••••	Nałożenie materiału na powierzchnię
STAL NIERDZEWNA GŁADKA				••••	••••	••••	••••	Nałożenie materiału na powierzchnię
STAL NIERDZEWNA ZĘBATA							••••	Nałożenie materiału na powierzchnię
SZLIFOWANIE POLISTYRENU, PLASTIK			••				••••	Nakładanie materiału na powierzchnię, np: tynków, betonu, gipsu
SZLIFOWANIE POLISTYRENU, SKLEJKA			••				••••	Nakładanie materiału na powierzchnię

**FESTA**PACA PLASTIKOWA
Z BIAŁYM
FILCEM

Č.p.	specifikace	
34400	280 x 140 x 8 mm	15
34415	250 x 130 x 8 mm	15
34450	220 x 130 x 8 mm	15
34445	220 x 70 x 8 mm	20

**FESTA**PACA PLASTIKOWA
Z CZARNYM
FILCEM

Č.p.	specifikace	
34401	280 x 140 x 10 mm	15
34416	250 x 130 x 10 mm	15
34451	220 x 130 x 10 mm	15
34446	220 x 70 x 10 mm	20

**FESTA**PACA PLASTIKOWA
Z GŁADKIM
POLIURETANEM

Č.p.	specifikace	
34404	280 x 140 x 30 mm	10
34485	280 x 130 x 20 mm	10
34486	250 x 130 x 30 mm	10
34419	250 x 130 x 20 mm	10
34453	220 x 130 x 20 mm	10
34447	220 x 70 x 20 mm	10

**FESTA**PACA PLASTIKOWA
Z GĄBKĄ

Č.p.	specifikace	
34405	280 x 140 x 18 mm	15
34420	250 x 130 x 18 mm	15
34454	220 x 130 x 18 mm	15
34449	220 x 70 x 18 mm	20
34480	280 x 140 x 12 mm	15
34481	250 x 130 x 12 mm	15
34482	220 x 130 x 12 mm	15

**FESTA**PACA PLASTIKOWA
Z SZORSTKIM
POLIURETANEM

N.p.	specyfikacja	
34443	280 x 140 x 12 mm	15
34442	250 x 130 x 12 mm	15

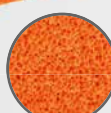
**FESTA**PACA PLASTIKOWA
Z SZORSTKIM
POLIURETANEM

N.p.	specyfikacja	
34441	280 x 140 x 12 mm	15
34440	250 x 130 x 12 mm	15
34439	250 x 130 x 18 mm	15



FESTA

PACA PLASTIKOWA
Z NACINANYM
POLIURETANEM



N.p.	specyfikacja	
34409	280 x 140 x 30 mm	10
34425	250 x 130 x 20 mm	10

FESTA

PACA PLASTIKOWA
Z SZORSTKIM
POLIURETANEM



N.p.	specyfikacja	
34410	280 x 140 x 30 mm	10
34426	250 x 130 x 20 mm	10

FESTA

PACA PLASTIKOWA
Z GĄBKĄ
MORSKĄ



Č.p.	specifikace	
34406	280 x 140 x 30 mm	10
34421	250 x 130 x 30 mm	10
34455	220 x 130 x 30 mm	10

FESTA

PACA PLASTIKOWA
Z NACINANĄ
GĄBKĄ MORSKĄ



Č.p.	specifikace	
34413	280 x 140 x 30 mm	10
34428	250 x 130 x 30 mm	10

FESTA

PACA PLASTIKOWA
Z HYDRO GĄBKĄ
SZORSTKA



Č.p.	specifikace	
34412	280 x 140 x 30 mm	10
34424	250 x 130 x 30 mm	10
34458	220 x 130 x 30 mm	10

FESTA

PACA PLASTIKOWA
Z NACINANĄ
HYDRO
GĄBKĄ SZORSTKA



Č.p.	specifikace	
34490	280 x 140 x 30 mm	10
34491	250 x 130 x 30 mm	10

FESTA

PACA PLASTIKOWA
Z HYDRO GĄBKĄ
GŁADKA



Č.p.	specifikace	
34411	280 x 140 x 30 mm	10
34423	250 x 130 x 30 mm	10
34457	220 x 130 x 30 mm	10

FESTA

PACA PLASTIKOWA
Z GUMĄ



Č.p.	specifikace	
34402	280 x 140 x 10 mm	15
34417	250 x 130 x 10 mm	15
34452	220 x 130 x 10 mm	15

FESTA

PACA PLASTIKOWA
Z GUMĄ



Č.p.	specifikace	
34403	280 x 140 x 8 mm	15
34418	250 x 130 x 8 mm	15
34496	220 x 130 x 8 mm	15

FESTA

PACA PLASTIKOWA
Z DURENEM



Č.p.	specifikace	
34407	280 x 140 x 20 mm	10
34422	250 x 130 x 20 mm	10
34456	220 x 130 x 20 mm	10
34448	220 x 70 x 20 mm	10

FESTA

PACA
PLASTIKOWA
(RUVEN)



Č.p.	specifikace	
34414	280 x 140 x 20 mm	10
34429	250 x 130 x 20 mm	10

FESTA

PACA
PLASTIKOWA



Č.p.	specifikace	
30003	270 x 125 mm	28
30004	235 x 115 mm	35
30005	210 x 115 mm	38
30007	210 x 60 mm	44

FESTAPACA DO
SPOINOWANIAMADE IN
EU

Ć.p.	specyfikacja	
34033	240 x 95 mm	5

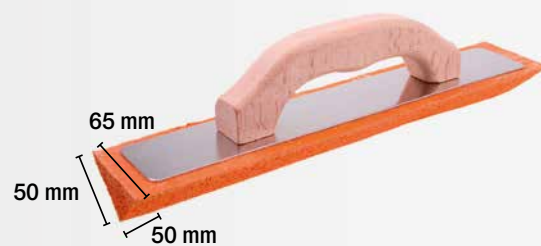
PACA
Z GĄBKĄ
90°

Ć.p.	specyfikacja	
34500	350 mm	6

WKŁAD ZAPASOWY
DO PACY
BIAŁY FILCMADE IN
EU

Ć.p.	specyfikacja	
34241	280 x 140 x 8 mm	1
34223	250 x 130 x 8 mm	1

WKŁAD ZAPASOWY
DO PACY –
CZARNY FILCMADE IN
EU

Ć.p.	specyfikacja	
34243	280 x 140 x 10 mm	1
34221	250 x 130 x 10 mm	1

WKŁAD ZAPASOWY
DO PACY
GĄBKĄMADE IN
EU

Ć.p.	specyfikacja	
34262	280 x 140 x 18 mm	1

WKŁAD ZAPASOWY
DO PACY GŁADKI
POLIURETANMADE IN
EU

Ć.p.	specyfikacja	
34251	280 x 140 x 30 mm	1

WKŁAD ZAPASOWY
DO PACY SZORSTKI
POLIURETANMADE IN
EU

N.p.	specyfikacja	
34261	280 x 140 x 30 mm	1

WKŁAD ZAPASOWY
DO PACY GĄBKĄ
MORSKAMADE IN
EU

N.p.	specyfikacja	
34265	280 x 140 x 30 mm	1

WKŁAD ZAPASOWY
DO PACY HYDRO
GĄBKĄ SZORSTKAMADE IN
EU

N.p.	specyfikacja	
34238	280 x 140 x 30 mm	1

WKŁAD ZAPASOWY
DO PACY HYDRO
GĄBKĄ GŁADKAMADE IN
EU

N.p.	specyfikacja	
34237	280 x 140 x 30 mm	1
34235	250 x 130 x 30 mm	1

WKŁAD ZAPASOWY
DO PACY GUMA
PIANKOWAMADE IN
EU

N.p.	specyfikacja	
34231	280 x 140 x 10 mm	1



FESTA

MIESZALNIK ELEKTRYCZNY DO MIESZANEK BUDOWLANYCH

Wejście	1800 W
Napięcie/częstotliwość	230 V / 50 Hz
Koła zębate	2
1. bieg (bieg jałowy)	0 - 450 ot./min.
2. bieg (bieg jałowy)	0 - 790 ot./min.
Ochrona przed przeładowaniem	Tak
Średnica kosza do mieszania	100 mm
Długość łopatki	570 mm
Waga	5,6 kg



N.p.	specyfikacja	
35311	mieszadło	1
35318	zapasowy węgiel	1
35319	zapasowe mieszadła - para (L+R)	1



FESTA

MIESZADŁO DO MATERIAŁÓW BUDOWLANYCH, 1600W

Pobór mocy	1600 W
Napięcie/częstotliwość	230 V / 50 Hz
Stopnie szybkości	2
1. stopień (wolne obroty)	0 - 480 ot./min.
2. stopień (wolne obroty)	0 - 800 ot./min.
Zabezpieczenie przed przeciążeniem	Tak
Gwint łopatki mieszającej	M 14
Średnica kosza mieszającego	140 mm
Długość łopatki	600 mm
Masa	4,7 kg



N.p.	specyfikacja	
35310		1
35317	zapasowy węgiel	1



FESTA

MIESZADŁO DO MATERIAŁÓW BUDOWLANYCH, 850W

Pobór mocy	850 W
Napięcie/częstotliwość	230 V / 50 Hz
Stopnie szybkości	1
1. stopień (wolne obroty)	0 - 500 ot./min.
2. stopień (wolne obroty)	-
Zabezpieczenie przed przeciążeniem	Tak
Gwint łopatki mieszającej	M 14
Średnica kosza mieszającego	120 mm
Długość łopatki	600 mm
Masa	3,7 kg



N.p.	specyfikacja	
35300		1
35316	zapasowy węgiel	1



**WEST
BERG****MIESZADŁO DO MATERIAŁÓW BUDOWLANYCH, 1600W**

Pobór mocy	1600 W
Napięcie/częstotliwość	230 V / 50 Hz
Stopnie szybkości	2
1. stopień (wolne obroty)	180 - 400 ot./min.
2. stopień (wolne obroty)	300 - 700 ot./min.
Zabezpieczenie przed przeciążeniem	Tak
Gwint łopatki mieszającej	M 14
Średnica kosza mieszającego	140 mm
Długość łopatki	600 mm
Masa	5,4 kg

M14 Zn CE

N.p.	specyfikacja	
35305		1
35315	zapasowy węgiel	1

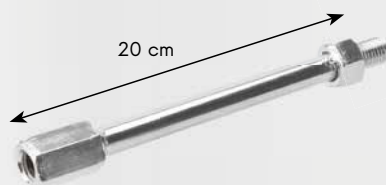
**NEW****FESTA****PRZEDŁUŻENIE
MIESZADŁA****M14**

N.p.	specyfikacja	
35142	M14	1

**NEW****FESTA****MIESZADŁO PRAWOOBROTOWE**

Mieszadło spiralne z 3 ostrzami i obręczą - prawostronne (zgodnie z ruchem wskazówek zegara) - dla gęstych mieszanek płynów w większych ilościach. Mieszany materiał jest mieszany „w dół”. Mieszany materiał nie chłapie poza wiadro. Doskonale miesza farby z pigmentem.

Zn	M14	N.p.	specyfikacja		
		35085	M14 Ø 120 x 600 mm	12	
		35086	M14 Ø 140 x 600 mm	12	
		35087	M14 Ø 160 x 600 mm	12	

**FESTA****MIESZADŁO LEWOOBROTOWE**

Mieszadło spiralne z 3 ostrzami i obręczą - lewostronne - do gęstych materiałów o wysokiej lepkości, zapraw, betonu, cementu i wapna, tynków, zapraw epoksydowych, spoiw bitumicznych. Efekt mieszania od dołu do góry.

Zn	M14	N.p.	specyfikacja		
		35091	M14 Ø 120 x 600 mm	12	
		35092	M14 Ø 140 x 600 mm	12	
		35093	M14 Ø 160 x 600 mm	12	

**FESTA****MIESZADŁO Z OBRĘCZĄ OCYNK**

Mieszadło spiralne z 2 ostrzami - do dokładnego mieszania materiałów np: zgranulowanego cementu, łączenia materiałów, wylewek, materiałów wygładzających.

Zn	N.p.	specyfikacja	
	35038	Ø 80 x 500 mm	24
	35058	Ø 100 x 500 mm	24
	35023	Ø 120 x 500 mm	24



FESTA

MIESZADŁO PRAWOOBROTOWE

Mieszadło spiralne z 2 ostrzami - do dokładnego mieszania materiałów np: zgranulowanego cementu, łączenia materiałów, wylewek, materiałów wygładzających..

SDS+	Zn	N.p.	specyfikacja	
		35094	Ø 80 x 500 mm	24
		35095	Ø 100 x 500 mm	24
		35096	Ø 120 x 500 mm	24



FESTA

MIESZADŁO PRAWOOBROTOWE

Mieszadło spiralne z 2 ostrzami - do dokładnego mieszania materiałów np: zgranulowanego cementu, łączenia materiałów, wylewek, materiałów wygładzających..



M14	Zn	N.p.	specyfikacja	
		35059	M14 Ø 90 x 550 mm	24



FESTA

MIESZADŁO Z OBREĆZĄ OCYNK PRZEDŁUŻONE

Mieszadło spiralne z 2 ostrzami - do dokładnego mieszania materiałów np: zgranulowanego cementu, łączenia materiałów, wylewek, materiałów wygładzających..

	Zn	N.p.	specyfikacja	
		35013	Ø 80 x 500 mm	24
		35006	Ø 100 x 500 mm	24
		35007	Ø 120 x 500 mm	24

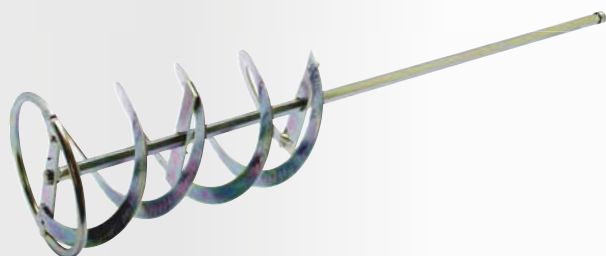

FESTA

MIESZADŁO Z OBREĆZĄ OCYNK PRZEDŁUŻONE

Mieszadło spiralne z 2 ostrzami - do dokładnego mieszania materiałów np: zgranulowanego cementu, łączenia materiałów, wylewek, materiałów wygładzających..



SDS+	Zn	N.p.	specyfikacja		
		35012	Ø 100 x 500 mm	24	



FESTA

MIESZADŁO SPIRALA DRUT

Mieszadło spiralne z 2 ostrzami - do dokładnego mieszania materiałów np: zgranulowanego cementu, łączenia materiałów, wylewek, materiałów wygładzających..

	Zn	N.p.	specyfikacja	
		35069	Ø 60 x 500 mm	50
		35078	Ø 80 x 500 mm	24
		35081	Ø 100 x 500 mm	24



FESTA

MIESZADŁO SPIRALA DRUT

Mieszadło spiralne z 2 ostrzami - do dokładnego mieszania materiałów np: zgranulowanego cementu, łączenia materiałów, wylewek, materiałów wygładzających..

SDS+	Zn	N.p.	specyfikacja	
		35070	Ø 60 x 500 mm	50
		35079	Ø 80 x 500 mm	24
		35082	Ø 100 x 500 mm	24



FESTA**MIESZADŁO BEZ OBRECZY OCYNK**

Mieszadło spiralne z 2 ostrzami - do dokładnego mieszania materiałów np: zgranulowanego cementu, łączenia materiałów, wylewek, materiałów wygładzających.

N.p.	specyfikacja	
35048	Ø 70 x 500 mm	24
35068	Ø 90 x 500 mm	24

**FESTA****MIESZADŁO SPIRALA OCYNK**

Odpowiednie dla materiałów wysoko-wiskozowych, spoiw, stosowanych w budownictwie takich jak kleje i cementy, gipsy, wylewki samopoziomujące itp. materiały dla podłogi.

N.p.	specyfikacja	
35021	Ø 90 x 500 mm	24

**FESTA****MIESZADŁO KIELICHOWE**

Mieszadło kielich - służy do mieszania materiałów nie wymagających wymiany powietrza. Do gładzi, materiałów chemicznych, materiałów uszczelniających, klejów.

N.p.	specyfikacja	
35015	Ø 100 x 500 mm	20

**FESTA****MIESZADŁO DO FARB - GWIAZDA**

Mieszadło śmigło - dla materiałów płynnych, farb, klejów do tapet ściennych.

N.p.	specyfikacja	
35011	Ø 80 x 500 mm	50

**MIESZADŁO OCYNK**

Mieszadło z obreczą - do dokładnego mieszania farb ściennych, farb rozproszonych, klejów, farb, powłok.

N.p.	specyfikacja	
35125	Ø 60 x 400 mm	40
35126	Ø 80 x 400 mm	40
35127	Ø 100 x 600 mm	20

**MIESZADŁO LAKIEROWANE**

Mieszadło z obreczą - do dokładnego mieszania farb ściennych, farb rozproszonych, klejów, farb, powłok.

N.p.	specyfikacja	
35103	Ø 60 x 400 mm	40
35113	Ø 80 x 400 mm	40
35123	Ø 100 x 600 mm	20



FESTA



PROFESJONALNE MISZT. ERY BUDOWLANE

Lescha

Betoniarki do najtrudniejszych prac budowlanych
 Koło zębate z żeliwa z patentowanym uchwytem
 Regulowany odstęp zębów
 Wysoka jakość wykończenia
 Podwójne ułożenie łożysk na dnie bębna
 Patentowana ochronna izolacje, zabezpieczenie w/g normy jakości DIN EN ISO 900
 Specjalnie zaprojektowany szt.żtałt bębnu
 Ochrona przed strzykającą wodą IP 45
 Dostarczane na 230V i 400V



Lescha
 BETONIARKA



N.p.	specyfikacja	
35500	Star 150 - 125 l, 230 V hamulec nożny	1



Lescha
 BETONIARKA



N.p.	specyfikacja	
35502	EUROMIX 125 l, 230 V	1
35503	EUROMIX 125 l, 400 V	1



Lescha
 BETONIARKA



N.p.	specyfikacja	
35501	BX 135 - 125 l, 230 V	1



Lescha
 BETONIARKA



N.p.	specyfikacja	
35504	ABM 135 l, 230 V nożni brzda	1



Lescha
 BETONIARKA



N.p.	specyfikacja	
35505	SM 145 S - 140 l, 230 V	1
35506	SM 145 S - 140 l, 400 V	1
35507	SM 145 S - 140 l, 230 V hamulec nożny	1
35508	SM 145 S - 140 l, 400 V hamulec nożny	1



Lescha
 BETONIARKA



N.p.	specyfikacja	
35510	SM 165 S - 160 l, 230 V hamulec nożny	1
35511	SM 165 S - 160 l, 400 V hamulec nożny	1
35512	SM 165 S - 160 l, G benzyna	1



Lescha
 BETONIARKA



N.p.	specyfikacja	
35514	SM 185 S - 180 l, 230 V hamulec nożny	1
35515	SM 185 S - 180 l, 400 V hamulec nożny	1



Lescha
 BETONIARKA



N.p.	specyfikacja	
35516	S 180 HR - 180 l, 230 V hamulec nożny	1
35517	S 180 HR - 180 l, 400 V hamulec nożny	1



Lescha
BETONIARKA



N.p.	specyfikacja	
35524	LB 354 230 V, 1,5 kW	1
35525	LB 354 400 V, 1,5 kW	1
35527	LB 354 Honda G200	1
35532	LB 404 230 V, 1,5 kW	1
35533	LB 404 400 V, 1,5 kW	1
35539	LB 484 Robin EH17B	1
35540	LB 484 Honda GX160LX	1
35542	AT 480 400 V, 1,2 kW	1

Lescha
BETONIARKA



N.p.	specyfikacja	
35518	S 230 HR - 230 l, 230 V hamulec nożny	1
35519	S 230 HR - 230 l, 400 V hamulec nożny	1

Lescha
BETONIARKA



N.p.	specyfikacja	
35552	LHB 1000 400 V	1
35553	LHB 1000 HATZ Diesel	1
35555	LHB 1200 400 V	1



BETONIARKA



N.p.	specyfikacja	
37500	MIX 130Zk 230 V niezmontowany	1
37501	MIX 130Z 230 V zmontowane	1
37505	MK 165Bk 230 V niezmontowany	1
37506	MK 165B 230 V zmontowane	1

130 L

specyfikacja	
objętość bębna	130 l
prędkość bębna	26±Min ⁻¹
pobór mocy	700 W
napięcie	230 V / 50 Hz
stopień ochrony	IP44
materiał wieńca	żeliwo
wymiary	długość 1170 mm
	szerokość 650 mm
	wysokość 1280 mm
waga	53 kg

165 L

specyfikacja	
objętość bębna	165 l
prędkość bębna	23±Min ⁻¹
pobór mocy	900 W
napięcie	230 V / 50 Hz
stopień ochrony	IP44
materiał wieńca	żeliwo
wymiary	długość 1295 mm
	szerokość 735 mm
	wysokość 1440 mm
waga	70 kg

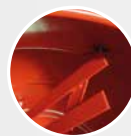

· specjalnie wykonane łopatki o grubości 4 mm



· jakościowe łożysko oporowe z pokrywą



· wyłącznik z osłoną zabezpieczającą



· plastikowa osłona napędu, wieniec z żeliwa

BETONIARKA



125 L

specyfikacja	
objętość bębna	125 l
prędkość bębna	26±Min ⁻¹
pobór mocy	550 W
napięcie	230 V / 50 Hz
stopień ochrony	IP44
materiał wieńca	żeliwo
wymiary	długość 1102 mm
	szerokość 690 mm
	wysokość 1310 mm
waga	52,5 kg

N.p.	specyfikacja	
37509	126 l, 230 V zmontowane	1
37510	126 l, 230 V niezmontowany	1

162 L

specyfikacja	
objętość bębna	162 l
prędkość bębna	26±Min ⁻¹
pobór mocy	650 W
napięcie	230 V / 50 Hz
stopień ochrony	IP44
materiał wieńca	żeliwo
wymiary	długość 1180 mm
	szerokość 710 mm
	wysokość 1310 mm
waga	56 kg

N.p.	specyfikacja	
37515	162 l, 230 V niezmontowany	1
37516	162 l, 230 V zmontowane	1



TACZKI



N.p.	specyfikacja	
37530	60 l, Ø 38 cm solidna opona	1
37532	60 l, Ø 40 cm opona pneumatyczna	1

142 L

specyfikacja	
objętość bębna	142 l
prędkość bębna	26±Min ⁻¹
pobór mocy	650 W
napięcie	230 V / 50 Hz
stopień ochrony	IP44
materiał wieńca	żeliwo
wymiary	długość 1164 mm
	szerokość 690 mm
	wysokość 1293 mm
waga	54 kg

N.p.	specyfikacja	
37511	142 l, 230 V niezmontowany	1
37512	142 l, 230 V zmontowane	1

180 L

specyfikacja	
objętość bębna	180 l
prędkość bębna	26±Min ⁻¹
pobór mocy	850 W
napięcie	230 V / 50 Hz
stopień ochrony	IP44
materiał wieńca	żeliwo
wymiary	długość 1164 mm
	szerokość 690 mm
	wysokość 1368 mm
waga	58 kg

N.p.	specyfikacja	
37517	180 l, 230 V niezmontowany	1
37518	180 l, 230 V zmontowane	1



TACZKI



N.p.	specyfikacja	
37527	80 l, Ø 40 cm opona pneumatyczna	1
37533	80 l, Ø 38 cm solidna opona	1

TACZKI



N.p.	specyfikacja	
37539	60 l	1

TACZKI



N.p.	specyfikacja	
37541	80 l	1

ZAPASOWE KOŁA



N.p.	specyfikacja	
48729	typ AA 400 opona pneumatyczna	1
48730	typ AA 380 solidna opona	1
48731	typ AA 380 solidna opona	1



TACZKA Z TRZEMA KOŁAMI



N.p.	specyfikacja	
37564	60 l	1

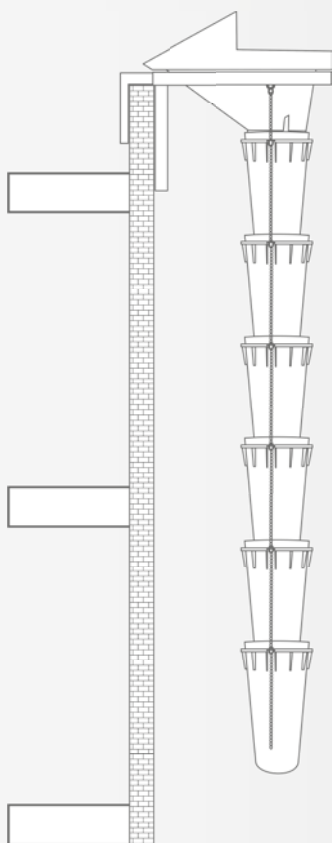

Lescha

ZSYP NA GRUZ



N.p.	specyfikacja	
35603	średnica podstawowa kropli 50/40 cm, długość 108 cm PE (HDPE)	1
35604	gruz budowlany PE (HDPE)	1
35605	rama nośna zapewniająca zgodność leja z gruzem budowlanym	1

HORIZONT®



HORIZONT®

ŁATA - BEZ LIBELLI

ALU

N.p.	specyfikacja	
15310	100 cm	10
15315	150 cm	10
15318	180 cm	10
15320	200 cm	10
15325	250 cm	10
15330	300 cm	10
15335	350 cm	10
15340	400 cm	10



HORIZONT®

ŁATA - 1 LIBELLA

ALU

N.p.	specyfikacja	
15415	150 cm	10
15418	180 cm	10
15420	200 cm	10
15425	250 cm	10
15430	300 cm	10



HORIZONT®

ŁATA - 2 LIBELLE

ALU

N.p.	specyfikacja	
15510	100 cm	10
15515	150 cm	10
15518	180 cm	10
15520	200 cm	10
15525	250 cm	10
15530	300 cm	10
15535	350 cm	10
15540	400 cm	5



HORIZONT®

ŁATA - BEZ LIBELLI Z UCHWYTAMI

ALU

N.p.	specyfikacja	
15615	150 cm	10
15620	200 cm	10
15625	250 cm	10
15630	300 cm	10



HORIZONT®

ŁATA - 2 LIBELLE I UCHWYTY

ALU

N.p.	specyfikacja	
15710	100 cm	10
15715	150 cm	10
15720	200 cm	10
15725	250 cm	10
15730	300 cm	10
15735	350 cm	10
15740	400 cm	5





HORIZONT
ŁATA - PROFIL TRAPEZ

PROFIL TRAPEZOWY

- profil trapezowy służy do lepszego wykończenia powierzchni
- nadaje się do sztukaterii i fasad
- nadaje się do tynków cienkowarstwowych

ALU	N.p.	specyfikacja	
	15810	100 cm	10
	15812	120 cm	10
	15815	150 cm	10
	15818	180 cm	10
	15820	200 cm	10
	15825	250 cm	10
	15830	300 cm	10



HORIZONT
ŁATA - PROFIL H

PROFIL "h"

- profil "h" służy do lepszego wykończenia powierzchni
- nadaje się do sztukaterii i fasad
- nadaje się do tynkowania sufitów

ALU	N.p.	specyfikacja	
	15850	100 cm	10
	15853	150 cm	10
	15855	180 cm	10
	15860	200 cm	10
	15870	250 cm	10
	15880	300 cm	10

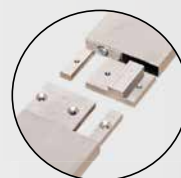
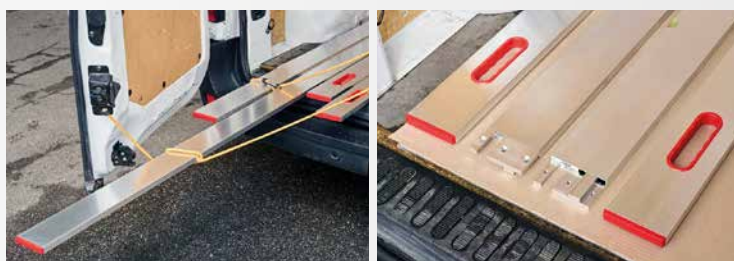

NEW

HORIZONT
SPRZĘGŁO
DLA
LATÓW HORIZONT

N.p.	specyfikacja		
15301		1	



HORIZONT
ŁATA - 1 LIBELLA
REGULOWANA

N.p.	specyfikacja		
15893	65 - 100 cm	1	
15894	95 - 150 cm	1	
15895	145 - 235 cm	1	



HORIZONT
KĄTOWNIK

ALU	N.p.	specyfikacja	
	14485	800 x 1200 mm	1
	14486	1000 x 1500 mm	1



**FESTA**

GIĘTARKA DO PRĘTÓW



N.p.	specyfikacja	
26730	Ø 6 - 14 mm	1
26731	Ø 5 - 8 mm	1

**NEW****FESTA**

UCHWYT DO NOSZENIA CEGIEŁ



N.p.	specyfikacja	
60130	27 - 45 cm	10

NEW**FESTA**

UCHWYT DO NOSZENIA CEGIEŁ



N.p.	specyfikacja	
60132		1

NEW**FESTA**

CIĘŻARÓWKA DO UKŁADANIA KOSTKI BRUKOWEJ

· max 150 kg



N.p.	specyfikacja	
60157		1



GIĘTARKA DO PRĘTÓW

N.p.	specyfikacja	
26735	max Ø 13 mm 56 cm	1

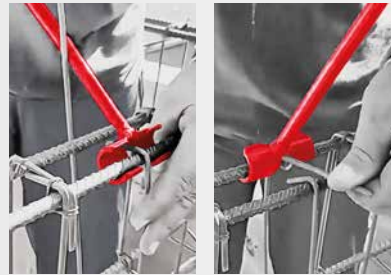
**NEW**

GIĘTARKA DO PRĘTÓW

· Ø 4-8 mm

N.p.	specyfikacja	
26736		1

**NEW****FESTA**

GILOTYNA DO CIĘCIA KOSTKI BRUKOWEJ

· max 45 kg

N.p.	specyfikacja	
60125		1

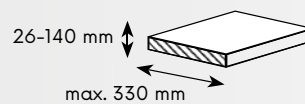
**NEW****FESTA**

CIĘŻARÓWKA DO UKŁADANIA KOSTKI BRUKOWEJ

· max 100 kg



N.p.	specyfikacja	
60155		1



30 - 50 cm

UCHWYT DO NOSZENIA CEGIEŁ

N.p.	specyfikacja	
36310	max. 20kg	5



CHWYTAK DO KRAWĘŻNIKÓW

specyfikacja	60116
rozmiar szczebli	750-1000 mm
maszt. . obciążenie	120 kg

N.p.	specyfikacja	
60116	PRO 041	1



CHWYTAK DO KRAWĘŻNIKÓW

specyfikacja	60115
rozmiar szczebli	80-370 mm
maszt. . obciążenie	50 kg

N.p.	specyfikacja	
60115	PRO 040	1



CHWYTAK DO KRAWĘŻNIKÓW

specyfikacja	60117	60118
rozmiar szczebli	500-1000 mm	0-500 mm
maszt. . obciążenie	150 kg	150 kg

N.p.	specyfikacja	
60117	PRO 042	1
60118	PRO 043	1



MŁOTEK DO RÓWNIANIA RZĘDÓW

specyfikacja	60121	60123
wysokość	200 mm	200 mm
szerokość	70 kg	70 kg
długość	870 mm	450 mm
masa	2,5 kg	2,2 kg

N.p.	specyfikacja	
60121	870 mm	1
60123	450 mm	1



PODKŁADKA

N.p.	specyfikacja	
37166	D10 basic	25



KRAŻEK LINOWY Z 500

N.p.	specyfikacja	
26780	0,5 t A z hakiem	1
26781	0,5 t B z okiem	1
26782	0,5 t C z hakiem i zabezpieczeniem	1
26783	0,5 t D z okiem i zabezpieczeniem	1



UBIJAK RĘCZNY

N.p.	specyfikacja	
26740	12 kg	1



WÓZEK RĘCZNY

N.p.	specyfikacja	
48719	260 mm solidna opona 250 kg	1





PROFESJONALNE PRZECINARKI DO PŁYTEK

- przecinarki do płytek dla najbardziej skomplikowanych profesjonalnych czynności
- 9 zabudowanych łożysk kulkowych SKF,
- 4 są regulowane i dostosowują luz przesuwu
- amortyzowane podstawy
- można dostosować do pracy lewą ręką
- zapewniamy komplet części zamiennych i serwis
- kółka tnące ze stali chromowo-wolframowej



Super Pro



MASZYNA DO GLAZURY SUPER PRO "EVO"

- 36195 zapasowe kółko tnące - Ø 22 mm



N.p.	specyfikacja
36191	1250 mm

1

Super Pro



MASZYNA DO GLAZURY SUPER PRO

- 36195 zapasowe kółko tnące - Ø 22 mm



N.p.	specyfikacja	
36145	SUPER PRO 450 mm	1
36160	SUPER PRO 600 mm	1
36175	SUPER PRO 750 mm	1
36190	SUPER PRO 900 mm	1



· illustrative photo

STOJAK SUPER PRO



N.p.	specyfikacja	
36200	stojak	1
36199	stojak 36160, 36175, 36190	1



FESTA

MASZYŃKA DO GLAZURY „X”

· 36138 zapasowe kołko tnące - Ø 22 mm



N.p.	specyfikacja	
36085	600 mm	1
36087	900 mm	1
36086	1300 mm	1



NEW

FESTA

MASZYŃKA DO GLAZURY

· 36139 zapasowe kołko tnące - Ø 22 mm



N.p.	specyfikacja	
36102	1050 mm	1
36103	1300 mm	1
36105	1550 mm	1



FESTA

MASZYŃKA DO GLAZURY

· 36195 zapasowe kołko tnące - Ø 22 mm



N.p.	specyfikacja	
36080	600 mm	1
36081	750 mm	1
36082	900 mm	1
36076	750 mm zmontowane	1
36077	900 mm zmontowane	1



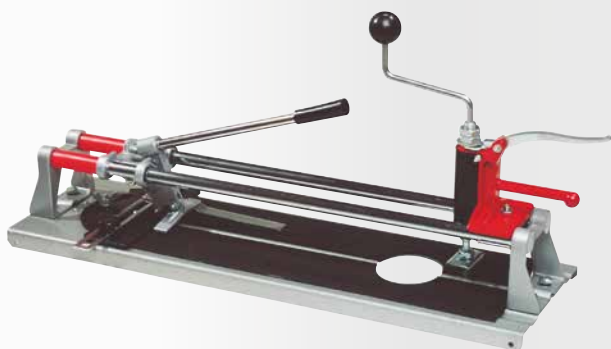

MASZYŃKA DO GLAZURY

· 36128 zapasowe kółko tnące - Ø 16 mm



N.p.	specyfikacja	
36014	480 mm	4

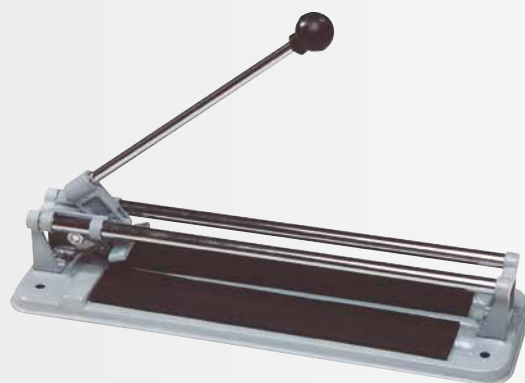

MASZYŃKA DO GLAZURY

· 36126 zapasowe kółko tnące - Ø 15 mm



N.p.	specyfikacja	
36024	300 mm	10
36034	400 mm	10
36035	600 mm	4



MASZYŃKA DO GLAZURY

· 36136 zapasowe kółko tnące - Ø 22 mm



N.p.	specyfikacja	
36036	480 mm	1



WYCINAK DO GLAZURY

· 36136 zapasowe kółko tnące - Ø 22,2 mm



N.p.	specyfikacja	
36046	22 mm	1



FESTA

SZYNA PROWADZĄCA DO CIĘCIA PŁYTEK POD KĄTEM 45°

Zestaw zawiera:

- szyna prowadząca
- pompa do chłodzenia wodnego
- zapasowy wąż do chłodzenia wodnego
- torba transportowa

N.p.	specyfikacja	
24680		1



ZAPASOWE KÓŁKA DO PRZECINAREK



Broj	specyfikacja	
36126	a= Ø 15 mm, b= Ø 6 mm, c= 1,5 mm	1
36128	a= Ø 16 mm, b= Ø 6 mm, c= 3 mm	1
36130	a= Ø 20 mm, b= Ø 6 mm, c= 5 mm	1
36136	a= Ø 22 mm, b= Ø 6 mm, c= 2 mm	1
36138	a= Ø 22 mm, b= Ø 6 mm, c= 5 mm	1
36139	a= Ø 22 mm, b= Ø 6 mm, c= 6 mm	1
36195	a= Ø 22 mm, b= Ø 6 mm, c= 4,8 mm	1



BRZESZCZOT DO WYCINANIA W GLAZURZE I CERAMICE

N.p.	specyfikacja	
24055	Karbid - BOSCH, MAKITA	1



OBCĘGI DO PŁYTEK



N.p.	specyfikacja	
36056		10



FESTA

SZCZYPCE DO PŁYTEK



N.p.	specyfikacja	
36057	200 mm	6



OBCĘGI DO PŁYTEK



N.p.	specyfikacja	
36059		1

OBCĘGI DO PŁYTEK



N.p.	specyfikacja	
36058	200 mm	6

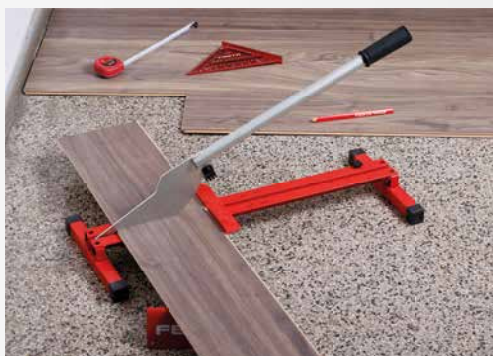

FESTA

NÓŻ DO WINYLU I LAMINATÓW



N.p.	specyfikacja	
36140	210 mm	4



NEW



FESTA

PRZYRZĄD

N.p. specyfikacja
37050

1

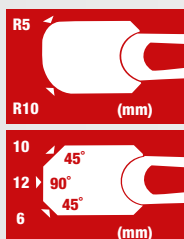

FESTA

PRZYRZĄD

N.p. specyfikacja
16056 145 mm

50

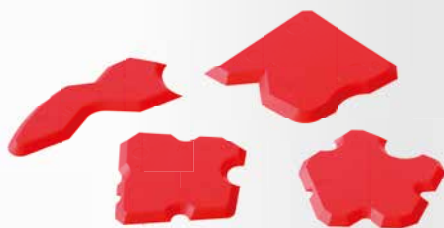

PRZYRZĄD ZESTAW

4x

N.p. specyfikacja
37052

1



PRZYRZĄD ZESTAW

4x

N.p. specyfikacja
37053

48

PRZYRZĄD DO
MODELOWANIA SYLIKONUN.p. specyfikacja
37054

1

PRZYRZĄD DO
MODELOWANIA SYLIKONU
do usuwania narożnikówN.p. specyfikacja
37055

1

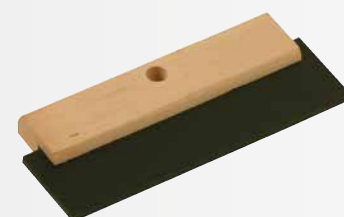
SZPACHLA DREWNIANA
Z GUMĄN.p. specyfikacja
37011 180 mm
37021 280 mm

12

12



37028



37029



37025



37026

GĄBKI 160 X 110 X 60 MM

N.p. specyfikacja
37028 hydro gąbką
37029 gąbka

1

1

GĄBKI 200 x 100 x 100 MM

N.p. specyfikacja
37025 miękkiej pianki
37026 gąbka

1

1



WIADRO GLAZURNICZE

N.p. specyfikacja
37117 zestaw
90070 pojemnik 25 l

1

1

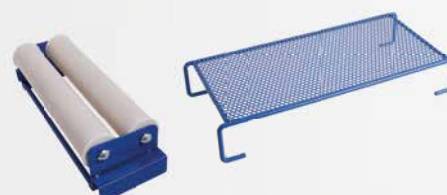

PRACE PORZĄDKOWE - AKCESORIA

N.p. specyfikacja
90072 Krata
90071 Rolki metalowe

1

1



4 mm

NARZĘDZIE DO CZYSZCZENIA SPOIN



N.p.	specyfikacja	
37012		1



37006

37007

NARZĘDZIE DO CZYSZCZENIA SPOIN



N.p.	specyfikacja	
37006	30 mm	20
37007	50 mm	20
37008	zapasowe ostrze 30 mm	50
37009	zapasowe ostrze 50 mm	50



APLIKATOR SILIKONU ZESTAW

3x



N.p.	specyfikacja	
16042		12

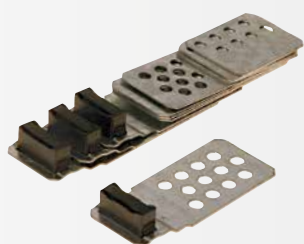

MAGNESY POD GLAZURĘ



4x



N.p.		
38920		1



REGULOWANE MAGNESY POD GLAZURĘ



4x



N.p.		
38923		24



NAROŻNIKI - ZESTAW

N.p.		
38919		50



WYCISKACZ DO FUGOWANIA

· capacity 1,5 l



N.p.	specyfikacja	
38026	5x tip	25



WOREK DO FUGOWANIA



N.p.	specyfikacja	
38042	3x tip	6

NEW

- Ø 10 mm
- Ø 14 mm
- Ø 20 mm
- Ø 10 x 35 mm

3 l

FESTA

APLIKATOR DO FUGOWANIA



Ø 10 mm

N.p.	specyfikacja	
38045		1



ZESTAW DO MONTAŻU PANELI PODŁOGOWYCH

24x

N.p.	specyfikacja	szt.	
52130		1	1



KLINY GLAZURNICZE

50x

N.p.	specyfikacja	szt.	
37210	95 x 45 x 15 - 0 mm	50	1
37211	70 x 30 x 8 - 0 mm	50	1



POMPKA UCISKOWA

· wymiar 15 x 17 cm
· maszt, ymalna wysokość 5 cm

N.p.	specyfikacja	szt.	
37220		1	1

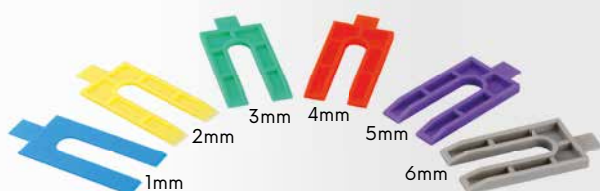

PRZEKŁADKI

30x

N.p.	specyfikacja	szt.	
37212	1 - 6 mm, 5 szt. dowolnej wielkości	1	1

FESTA

KLINY GLAZURNICZE



N.p.	specyfikacja	szt.	
37204	55 x 20 x 0 - 6 mm	20	1
37203	65 x 18 x 0 - 12 mm	20	1
37202	80 x 25 x 3 - 10 mm	20	1
37201	100 x 25 x 1 - 16 mm	14	1
37200	150 x 25 x 1 - 25 mm	8	1



FESTA

KLINY GLAZURNICZE

N.p.	specyfikacja	szt.	
37155	0 - 8 mm	30	100
37156	0 - 4 mm	100	100
37157	2,5 - 8 mm	30	100



FESTA

KLINY GLAZURNICZE

250x

N.p.	specyfikacja	szt.	
37205	55 x 8 x 0 - 10 mm	250	1



NEW

NIVELYS
LEVELING SYSTEM FESTA

PROFIL FUNDAMENTOWY POD PŁYTKĘ

ALU

N.p.	specyfikacja	szt.	
37105	50 cm	1	1
37106	100 cm	1	1
37107	150 cm	1	1



NEW



140 - 520 mm

NIVELYS
LEVELING SYSTEM FESTA

REGULOWANY SPÓD DO PROFILU FUNDAMENTOWEGO

· max. 50 kg

2x

N.p.	specyfikacja	szt.	
37102		1	1

NIVELYS

LEVELING SYSTEMS

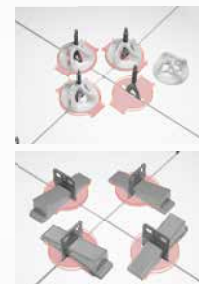

NIVELYS
LEVELING SYSTEMS FESTA

GWINTOWANY KLIP DYSTANSOWY

50x

N.p.	specyfikacja	
37131	1 mm	40
37132	2 mm	40

NIVELYS
LEVELING SYSTEMS FESTA

CZAPKA POZIOMUJĄCA Z NITKĄ

50x

N.p.	specyfikacja	
37130		15

NIVELYS
LEVELING SYSTEMS FESTA

PŁYTKI OCHRONNE DO SYSTEMÓW POZIOMOWANIA PŁYTEK

100x

N.p.	specyfikacja	
37192		1

NIVELYS
LEVELING SYSTEMS FESTA

PRZEKŁADKI

kliny 37175, 37176

50x

N.p.	specyfikacja	szk.	
37170	1 mm	50	60
37171	2 mm	50	60
37172	3 mm	50	60

NIVELYS
LEVELING SYSTEMS FESTA

PRZEKŁADKI

100x

N.p.	specyfikacja	szk.		N.p.	specyfikacja	szk.	
37185	1 mm	100	1	37187	3 mm	100	1
37190	1,5 mm	100	1	37188	4 mm	100	1
37186	2 mm	100	1	37189	5 mm	100	1

NIVELYS
LEVELING SYSTEMS FESTA

PRZEKŁADKI

100x

N.p.	Specyfikacja	
37162	1,5 mm	1

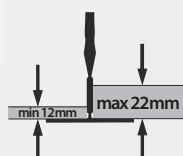

NIVELYS
LEVELING SYSTEMS FESTA

KLINY WYRÓWNUJĄCE

N.p.	szk.	
37175	50	40
37176	400	3



NIVELYS
LEVELING SYSTEMS FESTA

NIVELYS
LEVELING SYSTEMS **FESTA**

PRZEKŁADKI

600x

N.p.	specyfikacja	szt.	box	
37125	1 mm	600	38 x 28 x 19 cm	1
37126	1,5 mm	600	38 x 28 x 19 cm	1
37127	2 mm	600	38 x 28 x 19 cm	1

NIVELYS
LEVELING SYSTEMS **FESTA**

PRZEKŁADKI + KLINY WYRÓWNUJĄCE

N.p.	specyfikacja	
37173	1 mm, 400 szt. + 200 szt.	1
37174	1,5 mm, 400 szt. + 200 szt.	1

NIVELYS
LEVELING SYSTEMS **FESTA**

PISTOLET WYRÓWNUJĄCY

N.p.	
37177	1

NIVELYS
LEVELING SYSTEMS **FESTA**

PISTOLET WYRÓWNUJĄCY

N.p.	
37178	1

KLIPS POZIOMUJĄCY

50x

N.p.	specyfikacja	
37199	1,5 mm	40

NIVELYS
LEVELING SYSTEMS **FESTA**

KRZYŻYKI GLAZURNICZE

100x

N.p.	specyfikacja	szt.	
37195	1,0 mm	100	12
37196	1,5 mm	100	12
37197	2 mm	100	12
37198	3 mm	100	12

FESTA

KRZYŻYKI GLAZURNICZE

N.p.	specyfikacja	szt.	
37148	1,0 mm	200	100
37149	1,5 mm	200	100
37150	2 mm	200	100
37151	2,5 mm	200	100
37152	3 mm	150	100
37153	4 mm	100	100
37154	5 mm	75	100
37158	10 mm	30	100

FESTA

KRZYŻYKI GLAZURNICZE

100x

N.p.	specyfikacja	
37285	1,5 mm	100
37286	2 mm	100
37287	2,5 mm	100
37288	3 mm	100
37289	4 mm	100

NEW

horyzontalny pozycja 110 kg
 pionowy pozycja 80 kg

Ø 220 mm

USB-C

FESTA
POWER X TOOLS

PRZYSSAWKA AKU

220 mm 80kg 110kg ROUGH SURFACE USB-C Li-ion 3.6V 2Ah

N.p. specyfikacja

36326

1

FESTA

UCHWYT DO PŁYTEK ZE WSKAŹNIKIEM PODCIŚNIENIA

200 mm 140kg 100kg ROUGH SURFACE

N.p. specyfikacja

36325

1

FESTA

UCHWYT DO SZKŁA

pozycja	max. ładowność
horyzontalny pozycja	120 kg
pionowy pozycja	150 kg

ALU

N.p. specyfikacja

36318 potrójny 10

FESTA

UCHWYT DO SZKŁA

pozycja	max. ładowność
horyzontalny pozycja	80 kg
pionowy pozycja	100 kg

ALU

N.p. specyfikacja

36313 podwójny 20

FESTA

UCHWYT DO SZKŁA

pozycja	max. ładowność
horyzontalny pozycja	50 kg
pionowy pozycja	50 kg

ALU

N.p. specyfikacja

36314 prosty 20

UCHWYT DO SZKŁA

N.p. specyfikacja

36305 prosty 60

UCHWYT DO SZKŁA

N.p. specyfikacja

36306 podwójny 20

UCHWYT DO SZKŁA

pozycja	max. ładowność
horyzontalny pozycja	80 kg
pionowy pozycja	100 kg

N.p. specyfikacja

36319 potrójny 10

**FESTA**

SZNUREK TRASERSKI 30 M + KREDA 120 G

- 6x szybszy mechanizm nawijania
- Funkcja pionowania



N.p.

37070



6

**FESTA**

SZNUREK TRASERSKI 30 M + KREDA 150 G

- 5x szybszy mechanizm nawijania



N.p.

37065



6



SZNUREK TRASERSKI ABS 30 M + KREDA 180 G



N.p.

37069



10



SZNUREK TRASERSKI 30 M



N.p.

37066



25



SZNUREK TRASERSKI METALICZNY 30 M

ALU

N.p.

37068



25



SZNUREK TRASERSKI ABS 30 M



N.p.

37067



25

**FESTA**

KREDA TRASERSKA 180 G

N.p.	specyfikacja	
37096	niebieski	10
37094	lekki niebieski	10
37097	czerwony	10
37095	lekki czerwony	10
37098	czarny	10

**FESTA**

SZNUREK MURARSKI CZERWONY



N.p.

38895

50 m



24

38896

100 m

24

**FESTA**

SZNUREK MURARSKI ŻÓŁTY



N.p.

38899

50 m



24

38900

100 m

24

**FESTA**

SZNUREK MURARSKI 50 M

N.p.	specyfikacja	
38907	czerwony 1,0 mm	100
38908	czerwony 1,7 mm	100
38909	czerwony 2,0 mm	100



FESTA

**SZNUREK MURARSKI
50 M**

N.p.	specyfikacja	
38904	żółty 1,0 mm	100
38905	żółty 1,7 mm	100
38906	żółty 2,0 mm	100



FESTA

**SZNUREK MURARSKI
50 M**

N.p.	specyfikacja	
38910	pomarańczowy 1,0 mm	100
38911	pomarańczowy 1,7 mm	100
38912	pomarańczowy 2,0 mm	100



FESTA

**SZNUREK MURARSKI
50 M**

N.p.	specyfikacja	
38901	biały 1,0 mm	100
38902	biały 1,7 mm	100
38903	biały 2,0 mm	100



SZNUREK WOSKOWANY



N.p.	długość	Ø	
50920	50 m	1 mm	80



FESTA

PION ZE SZNURKIEM 15 M

N.p.	specyfikacja	
38916	150 g	10
38917	300 g	6
38918	500 g	5

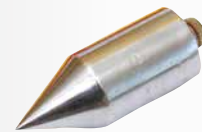

FESTA

PION

N.p.	specyfikacja	
38913	150 g	10
38914	300 g	10
38915	500 g	10

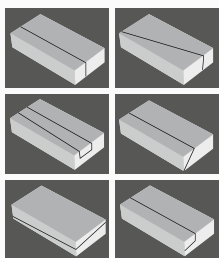

**FESTA****NÓZ DO STYROPIANU**

- Napięcie / częstotliwość 230 V/50 Hz
 - Pobór energii 200 W
 - Długość cięcia 137 cm
 - Wysokość cięcia 30 cm
 - Ochrona IP44
 - Kąt cięcia 0° - 90°
- sprzęt: stojak, włącznik nożny, Ni-Cr drut tnący, czyszczenie szczotki mosiężnej, narzędzia, złącza, walizka z kółkami



N.p. Specyfikacja

35348

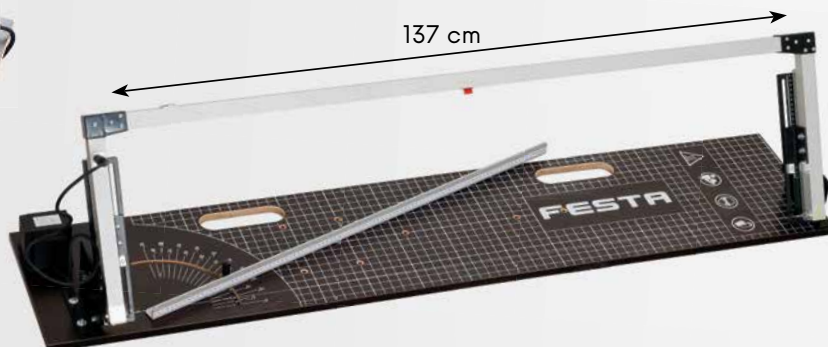
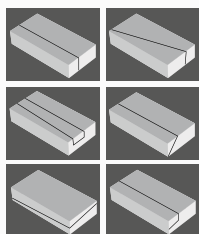

1

**FESTA****NÓZ DO STYROPIANU**

- Napięcie / częstotliwość 230 V / 50 Hz
- Pobór energii 200 W
- Długość cięcia 137 cm
- Wysokość cięcia 30 cm
- Ochrona IP44
- Kąt cięcia 0° - 90°



• sprzęt: Ni-Cr drut tnący, czyszczenie szczotki mosiężnej, inbus

Nu. specyfikacja

35345



1

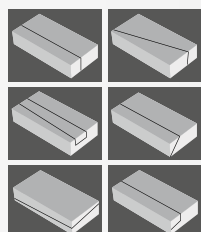

FESTA

NÓŻ DO STYROPIANU

- Napięcie / częstotliwość
- Pobór energii
- Długość cięcia
- Wysokość cięcia
- Ochrona
- Kąt cięcia

230 V / 50 Hz
160 W
120 cm
52 cm
IP44
0° - 90°



· sprzęt: Ni-Cr drut tnący, czyszczenie szczotki mosiężnej, inbus

Nu. specyfikacja

35344



1

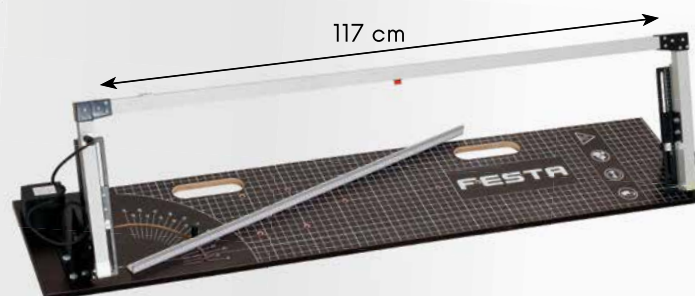
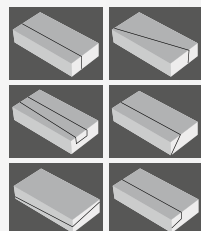

FESTA

NÓŻ DO STYROPIANU

- Napięcie / częstotliwość
- Pobór energii
- Długość cięcia
- Wysokość cięcia
- Ochrona
- Kąt cięcia

230 V / 50 Hz
160 W
120 cm
30 cm
IP44
0° - 90°



· sprzęt: Ni-Cr drut tnący, czyszczenie szczotki mosiężnej, inbus

Nu. specyfikacja

35330



1

**FESTA**

WTĄCZNIK NOŻNY DO PRZECINARKI DO STYROPIANU

· for | for 35330, 35345, 35348



N.p. Specyfikacja

35334

1

**FESTA**

STOJAK NA PRZECINARKĘ DO STYROPIANU

· for | for 35330, 35345, 35348



N.p. Specyfikacja

35336

1

**FESTA**

ZAPASOWA SPREŻYNA

· for | for 35330, 35345, 35348

N.p. Specyfikacja

35332

1

**FESTA**

UCHWYT RUSZTOWANIA

· for | for 35330, 35345, 35348

N.p. Specyfikacja

35333



1

**FESTA**

ZAPASOWY ZASILACZ DO PRZECINARKI DO STYROPIANU

· dla 35330, 35345, 35348



napięcie/częstotliwość: 230 V / 50Hz

wyjście: 36 V / 5 A

moc: 200 W



N.p. Specyfikacja

35347

1

ZAPASOWY DRUT DO CIĘCIA CR-NI DO PRZECINARKI DO STYROPIANU

N.p. Specyfikacja

35331 117 cm

35346 137 cm



1





FESTA

AKUMULATOROWA PRZECINARKA DO STYROPIANU

- bateria 36 V, 1,5Ah Li-ion
- Pobór energii 180 W
- Temperatura max 350 C°
- Długość noża 20 cm
- wyposażenie: 2 akumulatory, ładowarka, ostrze, mosiężna szczotka do czyszczenia, imbus



N.p.	specyfikacja	
35323	przecinarka do styropianu	1
35328	zapasowy nóż - długość 14 cm	1
35329	zapasowy nóż - długość 25 cm	1

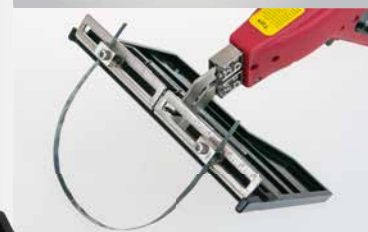

FESTA

PRZECINARKA DO STYROPIANU

- Napięcie / częstotliwość 230 V/50 Hz
- Pobór energii 250 W
- Temperatura 50-600 C°
- Długość noża 25 cm
- Długość kabla zasilającego 3 m



· sprzęt: czyszczenie szczotki mosiężnej, imbus, ostrze 25 a 30 cm

N.p.	specyfikacja	
35326	przecinarka do styropianu	1
35328	zapasowy nóż - długość 14 cm	1
35329	zapasowy nóż - długość 25 cm	1



FREZ DO PŁYT KANAŁOWYCH

N.p.	specyfikacja	
35327	przewodnica do cięcia polistyrenu	1
35335	zapasowy nóż - długość 30cm	1



FESTA

PRZECINARKA DO STYROPIANU



· kontrola temperatury

N.p.	specyfikacja	
35325	220 W	1



FESTA**FREZARKA DO STYROPIANU****ALU**

N.p.	specyfikacja	
24752	Ø 65 mm	1
24753	Ø 70 mm	1

**FREZARKA DO STYROPIANU**

N.p.	specyfikacja	
24727	Ø 65 mm	1
24729	Ø 68 mm	1
24728	Ø 70 mm	1

**KOŁKI****100x****MADE IN EU**

N.p.	specyfikacja		N.p.	specyfikacja	
39210	Ø 10 x 100 mm	1	39218	Ø 10 x 180 mm	1
39212	Ø 10 x 120 mm	1	39217	Ø 10 x 200 mm	1
39214	Ø 10 x 140 mm	1	39219	Ø 10 x 220 mm	1
39216	Ø 10 x 160 mm	1			

**FESTA****KOŁEK DO IZOLACJI DLA TULEJKI ŚRUB POCIĄGOWYCH****2x**

N.p.	specyfikacja	
39240	biały M10	1
39241	szary M10	1
39242	antracyt M10	1
39243	brązowy M10	1
39244	czarny M10	1

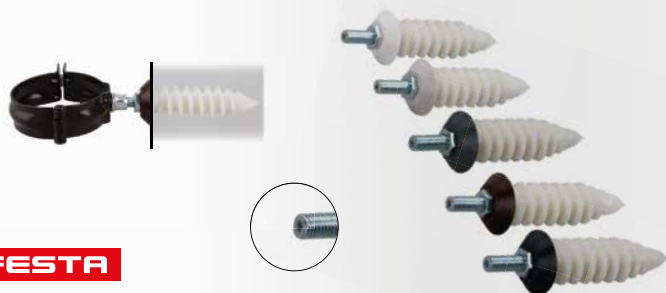
**PODKŁADKA DO DOCIEPLEŃ**

· dla śrub Ø 6 a 8 mm

50x

N.p.	Specyfikacja	
39208	Ø 68 mm	1

**PODKŁADKA DO DOCIEPLEŃ**

N.p.	specyfikacja	
39206	Ø 40 mm	200
39207	Ø 60 mm	100

**MOQ****WAŁEK DO WYLEWEK****MADE IN EU**

N.p.	diameter	wysokość hrotu	długość	
38950	Ø 69 mm	12 mm	25 cm	10
38951	Ø 69 mm	12 mm	40 cm	8
38952	Ø 122 mm	34 mm	25 mm	10
38953	Ø 122 mm	34 mm	40 cm	8
38954	Ø 122 mm	34 mm	60 mm	4

**PODESZWY Z KOLCAMI****MADE IN EU**

N.p.	specyfikacja	
38970	25 mm	1
38971	30 mm	1





CHWYTAK DO PŁYT



N.p.	specyfikacja	
42420	Ø 30 mm	1



SIATKA RABICO



N.p.	specyfikacja	
42312	1 m 50 bm 16 x 16 mm	1

DREWNIANY TYNK



N.p.	długość	grubość	szerokość	
37120	200 mm	1,7 mm	20 mm	10
37119	250 mm	1,7 mm	20 mm	10



SITO
MADE IN EU

N.p.	szerokość	wysokość	oko sita	
37216	50 mm	50 mm	2 mm	1
37217	50 mm	50 mm	3 mm	1
37218	50 mm	50 mm	4 mm	1

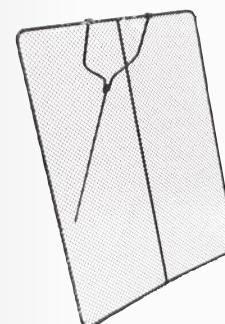

SITO

N.p.	szerokość	wysokość	oko sita	
37236	0,8 m	1 m	10 mm	1
37237	0,8 m	1 m	12 mm	1
37238	0,8 m	1 m	16 mm	1
37239	0,8 m	1 m	20 mm	1



WŁÓKNO PRZECIWDESZCZOWE DO BETONU

- +/- 150 g/ 50 kg cement
- 600 - 900 g/m² beton lub zaprawa murarska



N.p.	specyfikacja	
42115	0,9 kg	9



SIATKA NA RUSZTOWANIE

N.p.	specyfikacja	
42120	2,5 x 20 m, 80 g/ m ² zielony	5



NARZUTNICA DO TYNKU



N.p.	specyfikacja	
37114		1



NARZUTNICA DO TYNKU



N.p.	specyfikacja	
37115		1



HAK MURARSKI

Zn			
N.p.	specyfikacja	MOQ	
37231	14 cm single	10	



HAK MURARSKI

N.p.	specyfikacja	MOQ	
37232	14,5 cm	5	



HAK MURARSKI

N.p.	specyfikacja	MOQ	
37230	16 cm	6	

HAK MURARSKI

Zn			
N.p.	specyfikacja	MOQ	
37233	320 x 10 mm	100	
37234	320 x 12 mm	100	



HAK MURARSKI

N.p.	specyfikacja	MOQ	
37235	250 x 12 mm	1	

NAROŻNIK PAPIEROWY
Z DWOMA
PASKAM
ALUMINIOWYMI

ALU			
N.p.	specyfikacja	MOQ	
39245	AL 30 m x 5 cm	1	

NAROŻNIK
PLASTIKOWY

N.p.	specyfikacja	MOQ	
39238	3 m	25	

SZPACHLA DO PŁYT
GIPSOWO - KARTONOWYCH

N.p.	specyfikacja	MOQ	
34308	50 mm	20	
34307	80 mm	12	
34306	100 mm	10	
34305	150 mm	12	

PODNOŚNIK
DESKI

· winda 153 - 344 cm
· załaduj maszt. . 54 kg

N.p.	specyfikacja	MOQ	
26775		1	

ZESTAW DO ŁĄCZENIA
PŁYT GIPS-KARTON

N.p.	specyfikacja	MOQ	
34300	zestaw 9 szt.	10	
34303	wanienka	60	

**FESTA**

NOŚNIK

2x			
N.p.	specyfikacja	MOQ	
36312		12	

**FESTA**

NOŚNIK

N.p.	specyfikacja	MOQ	
36308	36 x 16,5 x 7,5 cm	10	





ZDZIERAK SURFORM

N.p.	specyfikacja	
22120	250 x 40 mm	10



ZDZIERAK SURFORM

N.p.	specyfikacja	
22121	250 x 40 mm	10
22122	140 x 40 mm	6



ZDZIERAK SURFORM

N.p.	specyfikacja	
22126	155 x 40 mm	1



ZDZIERAK SURFORM

N.p.	specyfikacja	
22125	Ø 250 x 40 mm	6



ZDZIERAK SURFORM

N.p.	specyfikacja	
22124	Ø 250 x 16 mm	10



ZDZIERAK SURFORM

N.p.	specyfikacja	
22123	60 x 40 mm	6

FESTA

PIŁA DO PŁYT KART.-GIPS.

N.p.	specyfikacja	
24159	150 mm	12

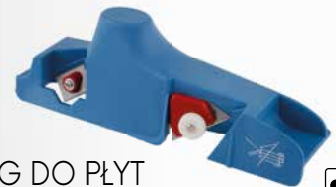

STRUG DO PŁYT KART.-GIPS.

N.p.	specyfikacja	
34315		10
34316	zapasowe ostrze	1



PIŁKA DO PŁYT KARTONOWO - GIPSOWYCH

N.p.	specyfikacja	
24190	300 mm	10

ZAPAS DO ZDZIERAKA

N.p.	specyfikacja	
22130	250 x 40 mm	20
22129	155 x 40 mm	20
22132	140 x 40 mm	20
22133	60 x 40 mm	20
22134	Ø 16 x 250 mm	20



FESTA**PALNIK PB**

· Ø 17, 22, 40 mm



N.p.	specyfikacja	
69918	2 kW, 3 m szlauch	10

**FESTA****PALNIK PB**

· Ø 25, 35, 50 mm



N.p.	specyfikacja	
69919	19,5 kW, 1,5 m szlauch	10

**FESTA****PALNIK PB 300 mm**

N.p.	specyfikacja	
69900	Ø 35 mm, długość 300 mm, bez węża	10



N.p.	specyfikacja	
69901	Ø 35 mm, długość 300 mm + 3 m szlauch	5

FESTA**ZESTAW DO LutowANIA 3 KW**

N.p.	specyfikacja	
69914	300 mm + 2 m szlauch	5

**FESTA****PALNIK PB**

N.p.	specyfikacja	
69902	Ø 55 mm, długość 550 mm, bez węża	10

**FESTA****PALNIK PB**

N.p.	specyfikacja	
69903	Ø 55 mm, długość 550 mm + 3 m szlauch	10

**FESTA****PALNIK PB**

N.p.	specyfikacja	
69905	Ø 55 mm, długość 900 mm, bez węża	10

**FESTA****PALNIK PB**

N.p.	specyfikacja	
69906	Ø 55 mm, długość 900 mm + 3 m szlauch	5



FESTA

PALNIK PB



Ø 55 mm



N.p. specyfikacja
69904 60 kW, 850 mm, 5 m szlauch

8

FESTA

PALNIK PB

regulator do podłączenia bomb 10 a 33 kg bomby



N.p. specyfikacja
69917 Ø 60 mm, długość 900 mm + 3 m szlauch 3 m

1

FESTA

SZLAUCH DO PALNIKA



N.p. specyfikacja
69910 3 m z zakończeniem 20
69911 5 m z zakończeniem 12
69912 10 m z zakończeniem 8

8



WENTYL REDUKCYJNY Z MANOMETREM

ciśnienie wlotowe	25 bar
ciśnienie wylotowe	0,5 - 4,0 bar
nominalna prędkość przepływu	16 kg h
połączenie wlotowe	W 21,8 x 1 14" LH
połączenie z gniazdem	G3 8" LH



N.p. specyfikacja
69907 1

WENTYL REDUKCYJNY

ciśnienie wylotowe	4,0 bar
nominalna prędkość przepływu	16 kg h
połączenie wlotowe	W 21,8 x 1 14" LH
połączenie z gniazdem	G3 8" LH

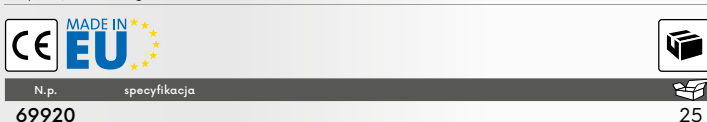

N.p. specyfikacja
69920 25

WENTYL REDUKCYJNY

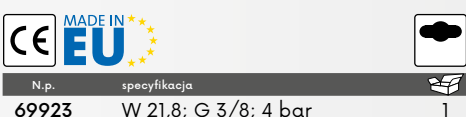

N.p. specyfikacja
69923 W 21,8; G 3/8; 4 bar 1

REGULATOR CIŚNIENIA



N.p. specyfikacja
69908 30 mBar, trn 1
69909 30 mBar, zavit G 1/4L 1

JEDNOKIERUNKOWY ZAWÓR CIŚNIENIOWY

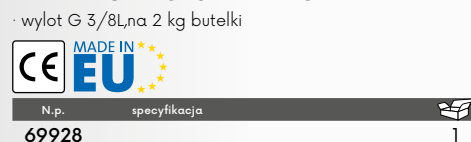

wylot G 3/8L, na 2 kg butelki
N.p. specyfikacja
69928 1

**FESTA****PALNIK GAZOWY NA WKŁAD GWINTOWANY**

· temperatura maszt. . . 1200 °C
 · wydajność 1,7 kW
 · średnica palnika Ø 20 mm



N.p. specyfikacja
69930 piezo

20

**FESTA****PALNIK GAZOWY NA WKŁADZIE PRZEBIJAJĄCYM**

· temperatura maszt. . . 1200 °C
 · wydajność 1,7 kW
 · średnica palnika Ø 20 mm



N.p. specyfikacja
69931 piezo

12

**MISKA NA GIPS**

N.p. specyfikacja
37121 stożkowa 1

**MISKA NA GIPS**

N.p. specyfikacja
37122 niska 1

**MISKA NA GIPS**

N.p. specyfikacja
33275 niska gumowy 20

**WIADRO OCYNK**

N.p.	specyfikacja	
39000	5 l	40
39001	10 l	30
39002	12 l	20
39003	15 l	20

**WIADRO MURARSKIE**

N.p.	specyfikacja	
39005	5 l	1
39010	10 l	1
39012	12 l	1
39014	15 l z dziubkiem	1
39020	20 l	1
39021	20 l z dziubkiem	1

**POJEMNIK BUDOWLANY Z UCHWYTAMI**

N.p.	specyfikacja	
39192	30 l	20
39193	45 l	20

KASTRY NA ZAPRAWĘ

N.p.	specyfikacja	
39045	45 l Ø 54 x 27 cm	1
39065	60 l Ø 60 x 35 cm	1
39090	90 l Ø 66 x 35 cm	1

**KASTRY NA ZAPRAWĘ PROSTOKĄTNE**

N.p.	specyfikacja	
39145	40 l 71 x 40 x 21 cm	1
39165	65 l 71 x 40 x 30 cm	1
39190	85 l 77 x 48 x 30 cm	1



FESTA

- odporny na uderzenia uchwyt nylon + włókno szklane



- Głowica obrotowa 360°

- 3 pozycje przełączania odbić się



- zmiana dawki 9:1 / 18:1



FESTA

PISTOLET DO WYTŁACZANIA Z PRZEŁĄCZNIKIEM ODBICIA

N.p. specyfikacja

38027

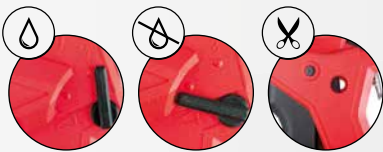

NEW



FESTA

PISTOLET DO WYTŁACZANIA Z PRZEŁĄCZNIKIEM ODBICIA

Č.p. Specifikace

38032 nylonová



24

FESTA

PISTOLET DO WYTŁACZANIA Z PRZEŁĄCZNIKIEM ODBICIA



N.p. specyfikacja

38028



FESTA

WYCISKACZ DO SILIKONU PROFI



N.p. specyfikacja

38013



12

FESTA

WYCISKACZ DO TUB



N.p. specyfikacja

38001



24

FESTA

WYCISKACZ DO TUB



N.p. specyfikacja

38012



6

FESTA

WYCISKACZ DO TUB



N.p. specyfikacja

38024



1

WYCISKACZ SZKIELETOWY



N.p. specyfikacja
38010 6ti hran 24

WYCISKACZ DO TUB



N.p. specyfikacja
38025 24

FESTA

WYCISKACZ DO KOTEW CHEMICZNYCH



N.p. specyfikacja
38020 12

WYCISKACZ KROKOWY



N.p. specyfikacja
38006 12

WYCISKACZ SZKIELETOWY



N.p. specyfikacja
38002 6ti hran 24

PISTOLET PLASTIK, SZKIELET SZEŚCIOKĄTNY



N.p. specyfikacja
38003 6ti hran 24

WYCISKACZ CHROMOWY



N.p. specyfikacja
38007 24

WYCISKACZ CYLINDRYCZNY PLASTIKOWY



N.p. specyfikacja
38008 24

WYCISKACZ CYLINDRYCZNY



N.p. specyfikacja
38009 24

WYCISKACZ CYLINDRYCZNY



N.p. specyfikacja
38000 24

FESTA

WYCISKACZ DO MAS
USZCZEL-
NIAJĄCYCH



ALU

N.p.	specyfikacja	
38005	310 ml	20
38014	tip 3 szt.	100

FESTA

WYCISKACZ DO MAS
USZCZEL-
NIAJĄCYCH



ALU

N.p.	specyfikacja	
38004	600 ml	12
38014	tip 3 szt.	100

FESTA

PISTOLET DO
PIANY PU,
TEFLON



TEFLON

N.p.	specyfikacja	
38018		20

FESTA

PISTOLET DO
PIANKI PU
TEFLON



TEFLON

N.p.	specyfikacja	
38017		20

FESTA

PISTOLET DO
PIANEK
PUR



TEFLON

TEFLON

N.p.	specyfikacja	
38016		20

FESTA

PISTOLET DO
PIANEK
PUR



TEFLON

TEFLON

N.p.	specyfikacja	
38015		20

PISTOLET DO
PIANEK
PUR



TEFLON

N.p.	specyfikacja	
38031		20

FESTA

PISTOLET DO
PIANEK
PUR



TEFLON

N.p.	specyfikacja	
38022	ABS	20

PISTOLET DO
PIANEK
PUR



TEFLON

N.p.	specyfikacja	
38021		24

DYSZA DO PISTOLETU
DO PIAN

· nadaje się do pistoletów 38015, 38016, 38017, 38018



TEFLON

N.p.	specyfikacja	
38030		5



PĘDZEL PŁASKI

N.p.	szerokość	grubość	długość	
52212	20 mm	15 mm	40 mm	12
52213	30 mm	15 mm	45 mm	12
52214	40 mm	15 mm	45 mm	12
52215	50 mm	15 mm	50 mm	12
52216	60 mm	15 mm	60 mm	12
52217	70 mm	15 mm	65 mm	12
52218	80 mm	15 mm	65 mm	12
52220	100 mm	15 mm	70 mm	12



PĘDZEL PŁASKI

N.p.	szerokość	grubość	długość	
52202	20 mm	12,5 mm	38 mm	12
52203	30 mm	13 mm	38 mm	12
52204	40 mm	14 mm	44 mm	12
52205	50 mm	16 mm	44 mm	12
52206	60 mm	17 mm	52 mm	12
52208	80 mm	17 mm	52 mm	12
52207	100 mm	18 mm	52 mm	12



PĘDZEL KALORYFEROWY

N.p.	szerokość	grubość	długość	
52283	25 mm	10 mm	44 mm	12
52284	38 mm	10 mm	44 mm	12
52285	50 mm	10 mm	44 mm	12
52286	62 mm	10 mm	50 mm	12
52288	76 mm	10 mm	50 mm	12



ZESTAW PĘDZLI

3x		
N.p.	specyfikacja	
52070	20, 30, 50 mm	50



PĘDZEL MALARSKI

MADE IN EU		
N.p.	specyfikacja	
52075	Ø 90 mm	10



PĘDZEL MALARSKI

MADE IN EU		
N.p.	specyfikacja	
52076	170 mm, 80 mm	10



ZESTAW PĘDZLI

5x		
N.p.	specyfikacja	
52071	15 mm, 25 mm, 40 mm, 60 mm, 80 mm	50



PĘDZEL MALARSKI

N.p.	specyfikacja	
52077	Ø 105 mm, 70 mm	12



PĘDZEL MALARSKI

N.p.	specyfikacja	
52078	170 mm, 70 mm	12

ZASTOSOWANIE WĄLKÓW MALARSKICH		RODZAJ FARBY LUB LAKIERU												
		EMULSJE DISPERZJI	ANTYKOROZYJNE ANTIKOROZYJNI	ŻYWIJĄCE SMOLA.	OLEJNE ULJNI	VODENI WODOR- OZCIECZALNE	POLIESTERNI POLIESTROWE	VEZIVA WIĄŻĄCE	LAZURE LAZURY	LATESZ. LATESZT. OWE	EPOSZT. EPOXYDOWE	2-KOMPONENTNI 2-KOMPONEN- TOWE	DEBELOSLOJNI GRUBOWARST- WOWE	AKRYLNI AKRYLOWE
MATERIAŁ	DIMENZIJE / mm WYSOKOŚĆ WŁOS / mm													
PES	20	•							•	•				
PES	20	•	•			•			•	•				•
PAC	18	•							•	•				
PAC	12, 13	•							•	•				
PAD	18, 21	•							•	•				
PAD	13	•	•						•	•				
LAMBSKIN	23	•							•	•				
NYLON	13		•	•	•	•	•		•	•	•			
VELOUR	4		•	•			•			•	•	•		
MICROFIBRE	10								•	•				
MOLITAN				•		•								•

WAŁEK MALARSKI POLYAKRYL

PAC

MADE IN EU



N.p.						
52331	100 mm	Ø 6 mm	Ø 17 mm	12 mm	50	
52334	250 mm	Ø 8 mm	Ø 48 mm	12 mm	10	

WAŁEK MALARSKI POLYAKRYL

PAC

MADE IN EU



N.p.						
52391	polster 5	250 mm	Ø 8 mm	Ø 54 mm	18 mm	10

WAŁEK MALARSKI POLYAKRYL

PAC

MADE IN EU



N.p.						
52328	polster 5	250 mm	Ø 8 mm	Ø 54 mm	18 mm	10
52456	polster 7	250 mm	Ø 8 mm	Ø 67 mm	18 mm	10

WAŁEK MALARSKI POLYAMID

PAD

MADE IN EU

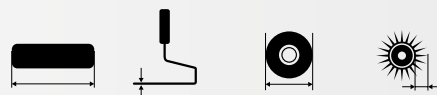

N.p.						
52428	polster 7	250 mm	Ø 8 mm	Ø 67 mm	18 mm	10

WAŁEK MALARSKI NYLON - LAKIER

PAD

MADE IN EU



N.p.						
52421	100 mm	Ø 6 mm	Ø 17 mm	13 mm	50	
52424	250 mm	Ø 8 mm	Ø 48 mm	13 mm	10	

WAŁEK MALARSKI POLYESTER

PES

MADE IN EU

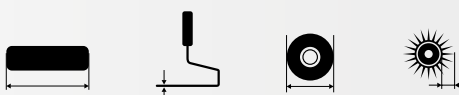

N.p.						
52305	180 mm	Ø 6 mm	Ø 42 mm	20 mm	10	
52306	250 mm	Ø 6 mm	Ø 42 mm	20 mm	10	

WAŁEK MALARSKI LAKIER MOLTOPREN

MADE IN EU

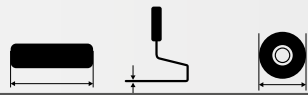

N.p.						
52471	proste	100 mm	Ø 6 mm	Ø 35 mm	50	



ZESTAW MALARSKI

PAC

MADE IN EU



N.p.	specyfikacja	ilość
52600	polster 4 180 mm Ø 8 mm Ø 53 mm 18 mm	1

ZESTAW MALARSKI

PES

MADE IN EU

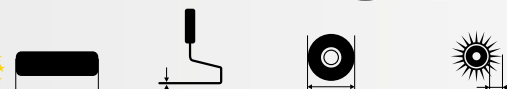

N.p.	specyfikacja	ilość
52610	180 mm Ø 6 mm Ø 42 mm 20 mm	25
52605	250 mm Ø 6 mm Ø 42 mm 20 mm	20

ZESTAW MALARSKI

- 1x wałek malarski PAD 13mm/10 cm
- 1x wałek malarski PAC 12mm/10 cm
- 1x wałek malarski PES 11cm
- handle + bowl

MADE IN EU



N.p.	ilość
52602	10

WAŁEK MALARSKI POLYAKRYL

PAC

MADE IN EU

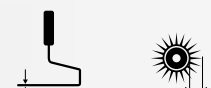

N.p.	specyfikacja	ilość
52601	z uchwytem Ø 6 mm 18 mm	1

TACA MALARSKA

MADE IN EU



N.p.	specyfikacja	ilość
52662	150 x 270 mm 100 mm	1
52666	260 x 290 mm 180 mm	1
52671	330 x 340 mm 250 mm	1

WIADRO MALARSKIE

MADE IN EU



N.p.	specyfikacja	ilość
52694	8 l	25
52695	12 l	20

KRATKA MALARSKA

MADE IN EU



N.p.	specyfikacja	ilość
52652	szerokość 230 mm wysokość 250 mm	100
52656	270 mm 290 mm	100



RĄCZKA DÓ WAŁKA

MADE IN EU



RĄCZKA DÓ WAŁKA



N.p.	specyfikacja	ilość
52640	5 cm Ø 6 mm	100
52645	8,5 cm Ø 6 mm x 27 mm	100

MADE IN EU

N.p.	specyfikacja	ilość
52630	18 cm Ø 6 mm	100
52635	25 cm Ø 6 mm	100
52620	18 cm Ø 8 mm	50
52625	25 cm Ø 8 mm	50

SKROBAK DO FARB I LAKIERÓW

N.p.	ilość
37005	12



FESTA

KIJ MALARSKI

gwint do 31610, 34203

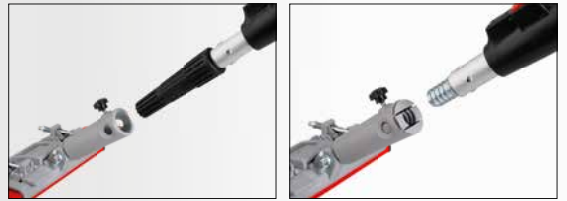

N.p.	Specyfikacja	
52011	88 - 140 cm	1



KIJ MALARSKI

ALU

N.p.	długość		
52010	120 cm	ALU	50
52012	240 cm	ALU	25



KIJ MALARSKI

N.p.	długość		
52020	300 cm	stal	10



KIJ MALARSKI

N.p.	długość		
52030	240 cm	fiberglass	6



TAŚMA MASKUJĄCA Z FOLIĄ

N.p.	szerokość	długość	
37243	55 cm	30 m	60
37244	110 cm	30 m	30
37245	140 cm	30 m	30
37246	180 cm	15 m	30
37290	210 cm	20 m	30
37247	240 cm	15 m	30
37291	270 cm	16 m	30



KOMBINEZON OCHRONNY Z KAPTUREM

N.p.	specyfikacja	
50585	size M	1
50586	size L	1
50587	size XL	1
50588	size XXL	1



FOLIA DO DRZWI Z ZAMKIEM BŁYSKAWICZNYM

N.p.	specyfikacja	
37248	1,2 x 2,2 m 100 µm tape 45 mm x 25 m	25



UNIWERSALNA FOLIA

N.p.	specyfikacja	grubość	
37250	4 x 5 m	0,007 mm	100
37251	4 x 12,5 m	0,007 mm	50
37252	2 x 50 m	0,007 role	20



UNIWERSALNA FOLIA

N.p.	specyfikacja	grubość	
37253	4 x 5 m	0,03 mm	100



TEKTURA FALISTA



N.p.	szerokość	długość	
54008	1 m	10 m	1

FESTA



PLANDEKA PROFI

niebiesko-srebrny

140 g/m²



N.p.	specyfikacja	
25206	2 x 3 m	25
25212	3 x 4 m	10
25215	3 x 5 m	8
25220	4 x 5 m	8
25224	4 x 6 m	8
25230	5 x 6 m	8

N.p.	specyfikacja	
25240	5 x 8 m	4
25248	6 x 8 m	3
25260	6 x 10 m	3
25296	8 x 12 m	2
25350	10 x 15 m	1



PLANDEKA EKONOMICZNY

niebieski



N.p.	specyfikacja	
25369	2 x 2 m	50
25370	2 x 3 m	20
25371	3 x 4 m	10
25372	3 x 5 m	10
25373	4 x 5 m	10

N.p.	specyfikacja	
25374	4 x 6 m	5
25376	5 x 8 m	5
25378	6 x 10 m	2
25379	8 x 12 m	2
25380	10 x 15 m	2

PLANDEKA STANDARD

niebiesko-srebrny

70 g/m²



N.p.	specyfikacja	
25155	2 x 2 m	50
25006	2 x 3 m	50
25009	3 x 3 m	35
25012	3 x 4 m	20
25015	3 x 5 m	10
25016	4 x 4 m	10
25020	4 x 5 m	10
25024	4 x 6 m	10

N.p.	specyfikacja	
25025	5 x 5 m	10
25030	5 x 6 m	10
25040	5 x 8 m	5
25048	6 x 8 m	5
25060	6 x 10 m	5
25096	8 x 12 m	2
25150	10 x 15 m	2
25153	15 x 20 m	1

PLANDEKA STANDARD

zielony

70 g/m²



N.p.	specyfikacja	
25179	2 x 2 m	50
25180	2 x 3 m	50
25195	2 x 8 m	20
25181	3 x 4 m	20
25182	3 x 5 m	10
25183	4 x 5 m	10

N.p.	specyfikacja	
25184	4 x 6 m	10
25186	5 x 8 m	5
25188	6 x 10 m	5
25189	8 x 12 m	2
25190	10 x 15 m	2

PLANDEKA PROFI

zielono-zielony

200 g/m²



N.p.	specyfikacja	
25160	2 x 3 m	15
25171	2 x 8 m	1
25162	3 x 5 m	5
25163	4 x 5 m	4

N.p.	specyfikacja	
25164	4 x 6 m	3
25167	6 x 8 m	2
25169	8 x 12 m	1
25170	10 x 15 m	1

PLANDEKA OKRĄGŁA

niebiesko-srebrny

120 g/m²



N.p.	specyfikacja	
25003	Ø 3,6 m	15
25004	Ø 4,5 m	5
25005	Ø 5,5 m	4
25002	Ø 6,5 m	3



NAPINACZ DO PLANDEK

4x

N.p.	specyfikacja	
25400	20 cm	1

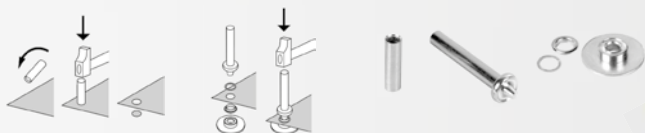

APLIKATOR OCZKA DO PLANDEK

N.p.	specyfikacja	
25410	aplikator + 25 oczka	1



OCZKA DO PLANDEK

10x

N.p.	specyfikacja	
25001		1



TELESKOPOWA DRABINA SKŁADANA

· maszt. ymalna nośność 150 kg



N.p.	specyfikacja		
48415	1,9 / 3,8 m	6/12 przegród	1

TELESKOPOWA DRABINA

· maszt. ymalna nośność 150 kg



N.p.	specyfikacja		
48410	3,2 m	11 przegród	1
48411	3,8 m	13 przegród	1

SKŁADANA PLATFORMA ROBOCZA

· maszt. ymalna nośność 150 kg



N.p.	specyfikacja	
48420		1



2.75m		1.73m		0.93m		0.99m	
H	L	H	L	H	L	H	L
1.60m	1.14m	1.69m	1.32m				



PLATFORMA ROBOCZA



· max 150 kg

N.p.	specyfikacja	
37660		1



KOZIOŁ BUDOWLANY



N.p.	specyfikacja	
37545	140 cm, wysokość 98 - 165 cm	1
37546	120 cm, wysokość 98 - 165 cm	1



PODPORA SZALUNKOWA

· 48449 klatka dla podpór



N.p.	specyfikacja	
48452	160 - 290 cm	1
48453	180 - 320 cm	1
48454	200 - 360 cm	1
48455	250 - 440 cm	1
48456	260 - 380 cm	1
48457	220 - 400 cm	1

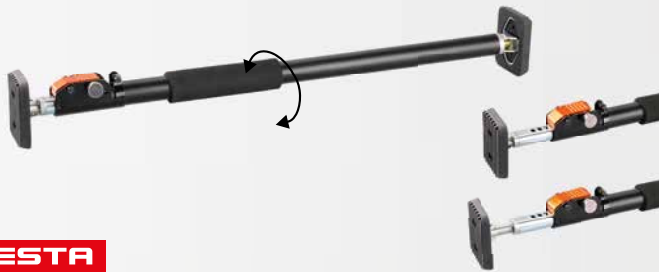

FESTA

HAK MURARSKI

· maszt, ymalna nośność 40 kg

N.p.	specyfikacja		
52060	66 - 115 cm	1	
52065	160 - 290 cm	1	



HAK MURARSKI

N.p.	specyfikacja		
52050	50 - 115 cm	1	
52055	115 - 290 cm	1	

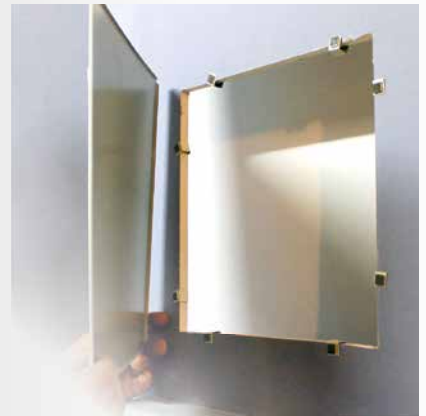

DRZWICZKI REWIZYJNE MAGNETYCZNY

	N.p.	specyfikacja	
	82100	10 - 21 cm	1
	82101	20 - 31 cm	1
	82102	30 - 41 cm	1
	82103	40 - 51 cm	1
	82104	50 - 58 cm	1



DRZWICZKI DO KOMINKA METALOWE



N.p.	specyfikacja	
65062		1

DRZWICZKI DO KOMINKA KOMAX



N.p.	specyfikacja	
65063	szary	1
65064	biały	1

DRZWICZKI DO KOMINKA OCYNKOWANE



N.p.	specyfikacja	
65065		1

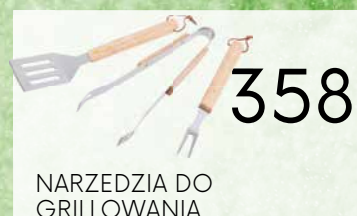



NARZĘDZIA OGRODOWE I
OGRODZENIA

308 - 359



NOŻYCE
OGRODNICZE

N.p.	specyfikacja	
45020	205 mm	10
44980	Sprezynki do sekatórow	1

NOŻYCE
OGRODNICZE

N.p.	specyfikacja	
45023	205 mm	10
44980	Sprezynki do sekatórow	1

NOŻYCE
OGRODNICZE

N.p.	specyfikacja	
45063	215 mm	10
44981	Sprezynki do sekatórow	1

NOŻYCE
OGRODNICZE

N.p.	specyfikacja	
44972	215 mm	10
44981	Sprezynki do sekatórow	1

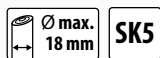
NOŻYCE
OGRODNICZE

N.p.	specyfikacja	
45099	190 mm	10
44983	Sprezynki do sekatórow	1

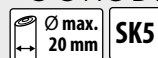
NOŻYCE
OGRODNICZE

N.p.	specyfikacja	
45098	220 mm	10
44983	Sprezynki do sekatórow	1

NOŻYCE
OGRODNICZE

N.p.	specyfikacja	
45095	200 mm	10
44982	Sprezynki do sekatórow	1

NOŻYCE
OGRODNICZE

N.p.	specyfikacja	
45096	220 mm	6
44982	Sprezynki do sekatórow	1

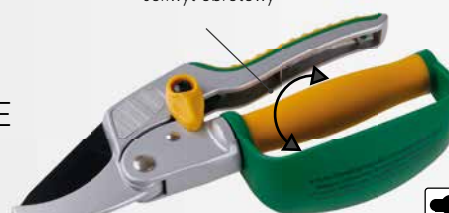



NOŻYCE OGRODNICZE



INOX max. mm INOX

N.p. specyfikacja
45089 160 mm



10



NOŻYCE OGRODNICZE



SK5 TEFLON SK5 TEFLON

N.p. specyfikacja
45097 210 mm
44981 Sprężynki do sekatorów



10

1



NOŻYCE OGRODNICZE



INOX max. 10 mm

N.p. specyfikacja
45088 160 mm



10



max. 12 mm

NOŻYCE OGRODNICZE

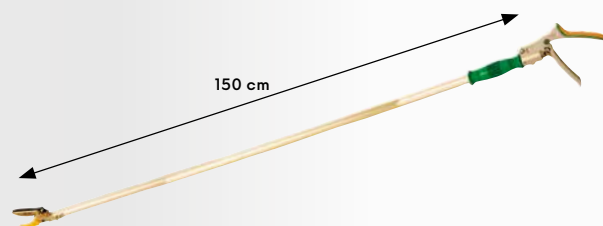

N.p. specyfikacja
45017



10



SPREŻYNKI DO SEKATORÓW



N.p.	nożyce	
44981	45021, 45025, 45063, 45097	1
44980	45020, 45023	1
44983	45098, 45099	1
44982	45027, 45095, 45096	1
44984	45110, 45014, 45026	1
44985	45018	1



ZAPASOWE OSTRZE

nożyce 45095, 45027



N.p. specyfikacja
45094



20



NOŻYCE DO GAŁĘZI DO GAŁĘZI



max. 45mm SK5 TEFLON

N.p. specyfikacja
44991 76 cm

12



NOŻYCE DO GAŁĘZI TELESKOPOWE



max. 45mm SK5 TEFLON

N.p. specyfikacja
44992 70 - 103 cm

10



NOŻYCE DO GAŁEZI

TEFLON

N.p.	specyfikacja	
44996	61 cm, faliste ostrze	12



NOŻYCE DO GAŁEZI

TEFLON

N.p.	specyfikacja	
44997	61 cm, proste ostrze	12



NOŻYCE DO TRAWY, OBROTOWA RĘKOJESC 360°

N.p.	specyfikacja	
44998		6



OSTRZAŁKA DO NOŻY I NOŻYCZEK 6 V 1

N.p.	specyfikacja	
45068		10



OSTRZAŁKA DO NOŻY I NOŻYCZEK

N.p.	specyfikacja	
45048		20



FESTA

NOŻYCE OGRODNICZE

nylonowy uchwyt



N.p.	specyfikacja	
45021	210 mm	6



NOŻYCE OGRODNICZE



N.p.	specyfikacja	
45019	210 mm	10



FESTA

NOŻYCE



N.p.	specyfikacja	
45010	190 mm	12
44984	Sprezynki do sekatorów	1



NOŻYCE



N.p.	specyfikacja	
45014	190 mm	12
44984	Sprezynki do sekatorów	1



NOŻYCE



N.p.	specyfikacja	
45026	150 mm	12
44985	Sprezynki do sekatorów	1



NOŻYCE OGRODNICZE



N.p.	specyfikacja	
45018	210 mm kute	10



NOŻYCE OGRODNICZE



N.p. specyfikacja
45025 200 mm



12

NOŻYCE OGRODNICZE



N.p. specyfikacja
44970 210 mm



10

NOŻYCE OGRODNICZE

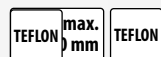

N.p. specyfikacja
45027 200 mm



10

NOŻYCE OGRODNICZE



N.p. specyfikacja
45029 200 mm



24

NOŻYCE OGRODNICZE

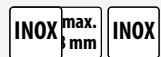

N.p. specyfikacja
44971 160 mm



10

NOŻYCE OGRODNICZE



N.p. specyfikacja
45016 180 mm



12

NOŻYCE OGRODNICZE

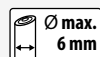

N.p. specyfikacja
45015 190 mm, proste



12

FUTERAŁ NA NOŻYCKI

N.p. specyfikacja
37317



1

NOŻYCE DO TRAWY

N.p. specyfikacja
45011 300 mm



1

NOŻYCE DO TRAWY, OBROTOWA RĘKOJEŚĆ 180°

N.p. specyfikacja
45012 370 mm, obrotowy 180°



1



NOŻYCE DO GAŁEZI



N.p. specyfikacja
44999 540 mm, zaokrąglone



12

FESTANOŻYCE
DO GAŁEZI

	Ø max. 30 mm	TEFLON
--	-----------------	--------

N.p.	specyfikacja	
45000	750 mm, zaokrąglone	6

FESTANOŻYCE
DO GAŁEZI

	Ø max. 25 mm	TEFLON
--	-----------------	--------

N.p.	specyfikacja	
45001	710 mm, zaokrąglone	6

FESTANOŻYCE
DO GAŁEZI

	Ø max. 40 mm	TEFLON
--	-----------------	--------

N.p.	specyfikacja	
45002	750 mm, grzechotkowy	12

NOŻYCE
DO GAŁEZI
TELESKOPOWE

	Ø max. 30 mm	TEFLON
--	-----------------	--------

N.p.	specyfikacja	
45003	660-900 mm, teleskopowe	6

FESTA

NOŻYCE DO GAŁEZI



	Ø max. 6 mm	TEFLON
--	----------------	--------

N.p.	specyfikacja	
45005	580 230 mm, faliste ostrze	6

FESTA

NOŻYCE DO ŻYWOPŁOTU



	Ø max. 6 mm	TEFLON
--	----------------	--------

N.p.	specyfikacja	
45006	580 230 mm, proste ostrze	6

FESTANOŻYCE DO ŻYWOPŁOTU
TELESKOPOWE

	Ø max. 6 mm	TEFLON
--	----------------	--------

N.p.	specyfikacja	
45007	670-870 230 mm, faliste ostrze	6

NOŻYCE DO ŻYWOPŁOTU



	Ø max. 10 mm	TEFLON	NYLON
--	-----------------	--------	-------

N.p.	specyfikacja	
44995	440 160 mm	12

NOŻYCE DO ŻYWOPŁOTU



N.p.	specyfikacja	
45009	500 190 mm, faliste ostrze	6

NOŻYCE DO ŻYWOPŁOTU



N.p.	specyfikacja	
45008	500 190 mm, proste ostrze	6

SIERP



N.p.	specyfikacja	
45490	450 mm	1



FESTA
MACZETA



TEFLON

N.p.	specyfikacja	
45069	440 mm	6

FESTA
MACZETA

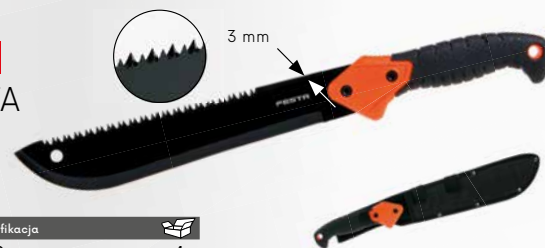

TEFLON

N.p.	specyfikacja	
44950	490 mm	4

MACZETA
NEREZ



INOX

N.p.	specyfikacja	
45083	430 mm	12
45084	600 mm	6

MACZETA



uchwyt jesionowy

N.p.	specyfikacja	
45081	510 mm	36
45082	710 mm	36

FESTA

PIŁA OGRODOWA SKŁADANA

3 x szlifowane, hartowane zęby

N.p.	specyfikacja	
45061	150 mm z osłoną rękojeść	12



FESTA

PIŁA OGRODOWA SKŁADANA

3 x szlifowane, hartowane zęby

N.p.	specyfikacja	
45060	180 mm	6



FESTA

PIŁA OGRODOWA

3 x szlifowane, hartowane zęby

N.p.	specyfikacja	
45062	260 mm z pochwą	24



FESTA

PIŁA OGRODOWA

3 x szlifowane, hartowane zęby

N.p.	specyfikacja	
24152	350 mm 7 tpi	12



FESTA

PIŁA TELESKOPOWA DO GAŁĘZI

3 x szlifowane, hartowane zęby

N.p.	specyfikacja	
45033	230 - 490 mm	1



NOŻYCE
DO GAŁĘZI

N.p.	specyfikacja	
45030	piłką 30 cm	6
45031	piłką 30 cm	6



NOŻYCE
DO GAŁĘZI

N.p.	specyfikacja	
45032	metalowe bez piłki	6



FESTA
FESTA
SIEKIERA
DIN 5131
DIN 7294

- jesionowy trzonek
- okrągły klin



N.p.	specyfikacja		N.p.	specyfikacja	
19380	600 g	1	19384	1400 g	1
19381	800 g	1	19385	1600 g	1
19382	1000 g	1	19387	2000 g	1
19383	1250 g	1			

FESTA
**SIEKIERA
CIESIELSKA**

- jesionowy trzonek



N.p.	specyfikacja	
19340	700 g	22

FESTA
SIEKIERA DO ROZŁUPYWANIA

- jesionowy trzonek
- okrągły klin

DIN 5129	N.p.	specyfikacja	
	19389	3000 g	1
	19388	4000 g	1

FESTA
SIEKIERA

- jesionowy trzonek
- okrągły klin

DIN 7294	N.p.	specyfikacja	
	19391	2000 g	1

FESTA
SIEKIERA FIBERGLASS

- uchwyt fiberglass

Ć.p.	specyfikacja	
19326	600 g	6
19328	800 g	24
19330	1000 g	12
19332	1250 g	8
19333	1500 g	6
19335	1600 g	6
19337	2000 g	6

FESTA
**SIEKIERA
FIBERGLASS**

- uchwyt fiberglass

Ć.p.	specyfikacja	
19392	1000 g	6

FESTA
**SIEKIERA CAMP
FIBERGLASS**

- uchwyt fiberglass

Ć.p.	specyfikacja	
19301	500 g	6

FESTA
SIEKIERA FIBERGLASS

- uchwyt fiberglass

N.p.	specyfikacja	
19390	2000 g	6





FESTA

SIEKIERA DO ROZŁUPYWANIA FIBERGLASS

uchwyt fiberglass

N.p.	specyfikacja	
19370	3000 g	4
19371	4000 g	4



JESIONOWY UCHWYT



Č.p.	specifikace	pro sekeru	
61340	36 cm	19380	10
61341	40 cm	19381, 19340	10
61342	50 cm	19382	10
61343	70 cm	19383, 19384	10
61344	80 cm	19385, 19391	10
61345	90 cm	19387	10
61346	90 cm	19388, 19389	10

SIEKIERA

Č.p.	specifikace	
19306	600 g	24
19308	800 g	24
19310	1000 g	24
19312	1250 g	12
19314	1500 g	12



KLIN DO ROZŁUPYWANIA

N.p.	specyfikacja	
19397	2000 g 55 x 210 x 45 mm	10
19465	2500 g 65 x 230 x 45 mm	10



KLIN DO ROZŁUPYWANIA



N.p.	specyfikacja	
19462	175 x 65 x 20 mm	1
19463	230 x 70 x 30 mm	1
19464	240 x 75 x 40 mm	1



KLIN DO ROZŁUPYWANIA

N.p.	specyfikacja	
19394	1000 g 35 x 180 x 40 mm	6
19395	2000 g 40 x 255 x 55 mm	6
19396	2500 g 40 x 260 x 55 mm	8



TRZPIEŃ ROZŁUPUJĄCY SDS+

SDS+



N.p.	specyfikacja	
19393	Ø 32 x 132 mm	10
19374	Ø 42 x 145 mm	10



KLIN ROZŁUPUJĄCY CZTERORAMIENNY

N.p.	specyfikacja	
19469	2500 g 165 x 87 mm	10

ŁOPATKA
SZEROKA
NIERDZ.

INOX



N.p.	specyfikacja	
45056	360 mm	12

ŁOPATKA
WĄSKA
NIERDZ.

INOX



N.p.	specyfikacja	
45057	360 mm	12

MOTYCZKA
NIERDZ.

INOX



N.p.	specyfikacja	
45058	270 mm	12

ODCHWASZCZACZ
Z KOLEBKĄ
NIERDZ.

INOX



N.p.	specyfikacja	
45059	360 mm	12

ŁOPATKA
SZEROKA
NYLON

NYLON



N.p.	specyfikacja	
45065	280 mm	1

ŁOPATKA
WĄSKA
NYLON

NYLON



N.p.	specyfikacja	
45066	310 mm	1

WIDEŁKI
OGRODNICZE
NYLON

NYLON



N.p.	specyfikacja	
45067	290 mm	1

ZESTAW
NARZĘDZI

HOBBY

4x



N.p.	specyfikacja	
45035	240 mm	35

MOTYKA
Z UCHWYTEM

N.p.	specyfikacja	długość nasady	
61294	140 mm	27 cm	MOQ 3
61221	uchwyt	27 cm	1



MOTYKA
Z UCHWYTEM

N.p.	specyfikacja	długość nasady	
61295	140 mm	27 cm	MOQ 3
61221	uchwyt	27 cm	1



MOTYKA
Z UCHWYTEM

N.p.	specyfikacja	długość nasady	
61296	175 mm	27 cm	MOQ 3
61221	uchwyt	27 cm	1



MOTYKA
Z UCHWYTEM

N.p.	specyfikacja	długość nasady	
61297	175 mm	27 cm	MOQ 3
61221	uchwyt	27 cm	1





ŁOPATKA

walizka

N.p.	specyfikacja	
61085	410 mm	6



SADZARKA DO CEBUL

INOX

N.p.	specyfikacja	
45040	230 mm	60



KOLEK DO SADZENIA "T"

N.p.	specyfikacja	
45038	280 mm	60



NÓŻ DO CHWASTÓW

N.p.	specyfikacja	
45079	200 mm	1



NÓŻ DO CHWASTY

N.p.	specyfikacja	
45080	200 mm „L”	1



URZADZENIE DO ZRYWANIA OWOCÓW



N.p.	specyfikacja	
45041		75



URZADZENIE DO ZRYWANIA OWOCÓW

N.p.	specyfikacja	
45039		50
45034	170 - 300 cm, teleskopowy uchwyt	5



KOMBAJN DO CHWASTÓW

N.p.	specyfikacja	
44955	950 mm	16



KULTYWATOR

N.p.	specyfikacja	
45042	160 x 132 cm	12



KULTYWATOR

N.p.	specyfikacja	
44053		12
61251	160 cm uchwyt	1



WÓZEK ROZRZUTNIK

specyfikacja	
wysokosc:	111 cm
szerokosc wide:	55 cm
objętość stosu volume:	12 l

N.p.	specyfikacja	
45085	12 l	1

FESTA

OSTRZAŁKA DO NOŻY I NOZYCZEK 16 W 1

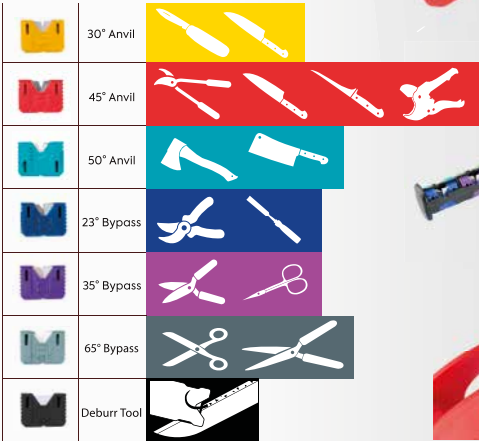

N.p. specyfikacja
45073 1



OSTRZAŁKA DO NOŻY I NOZYCZEK 6 W 1

N.p. specyfikacja
45068 10



OSEŁKA

N.p. specyfikacja
45048 20



OSEŁKA DO KOSY

N.p. specyfikacja
45046 205 x 15 mm 100



OSEŁKA DO KOSY

N.p. specyfikacja
45370 250 x 33 x 18 mm 20



OSEŁKA

N.p. specyfikacja
45045 150 x 50 x 30 mm 10



OSTRZAŁKA DO NOŻY I NOZYCZEK

N.p. specyfikacja
16991 20



OSEŁKA

N.p. specyfikacja
16990 Ø 50 mm 50





ŻYŁKI DO PODKASZAREK



N.p.	specyfikacja	
45530	2 mm x 15 m	1
45531	2,4 mm x 15 m	1
45532	3 mm x 15 m	1
45533	3,15 mm x 15 m	1
45534	4 mm x 15 m	1



ŻYŁKI DO PODKASZAREK

N.p.	specyfikacja	
45520	2 mm x 162 m	10
45521	2,4 mm x 112 m	10
45528	2,7 mm x 90 m	10
45522	3 mm x 72 m	10
45525	2 mm x 162 m	10
45526	2,4 mm x 112 m	10
45529	2,7 mm x 90 m	10
45527	3 mm x 72 m	10



ŻYŁKI DO PODKASZAREK

N.p.	specyfikacja	
45500	1,3 mm x 15 m	30
45502	1,3 mm x 15 m	30
45503	1,6 mm x 15 m	20
45505	1,6 mm x 15 m	20
45506	2 mm x 15 m	12
45508	2 mm x 15 m	12
45517	2 mm x 15 m	10
45509	2,4 mm x 15 m	12
45511	2,4 mm x 15 m	12
45512	2,4 mm x 15 m	12
45518	2,4 mm x 15 m	10
45523	2,7 mm x 15 m	10
45524	2,7 mm x 15 m	10
45513	3 mm x 15 m	10
45515	3 mm x 15 m	10
45516	3 mm x 15 m	10
45519	3 mm x 15 m	10



AGROTKANINA BIAŁA



17 g/m²

N.p.	specyfikacja	
45540	1,6 x 5 m	40
45541	1,6 x 10 m	40
45542	1,6 x 50 m w roli	1
45543	1,6 x 100 m w roli	1



AGROTKANINA CZARNA



50 g/m²

N.p.	specyfikacja	
45550	1,6 x 5 m	50
45551	1,6 x 10 m	20
45564	3,2 x 10 m	20
45552	1,6 x 50 m w roli	1
45553	1,6 x 100 m w roli	1
45562	3,2 x 50 m w roli	1
45563	3,2 x 100 m w roli	1



AGROTKANINA BRĄZOWA



50 g/m²

N.p.	specyfikacja	
45556	1,6 x 5 m	50
45557	1,6 x 10 m	20
45565	3,2 x 10 m	20
45558	1,6 x 50 m w roli	1
45559	1,6 x 100 m w roli	1

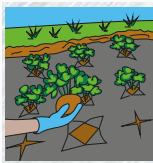

KLEJONA TKANINA Z SEKCJAMI DLA ROŚLIN

uv
STABLE 45 g/m²

N.p.	specyfikacja	
45535	1,6 x 5 m	18

KOLEK DO ZAMOCOWANIA

10x

N.p.	specyfikacja	
45555	11,5 cm	1

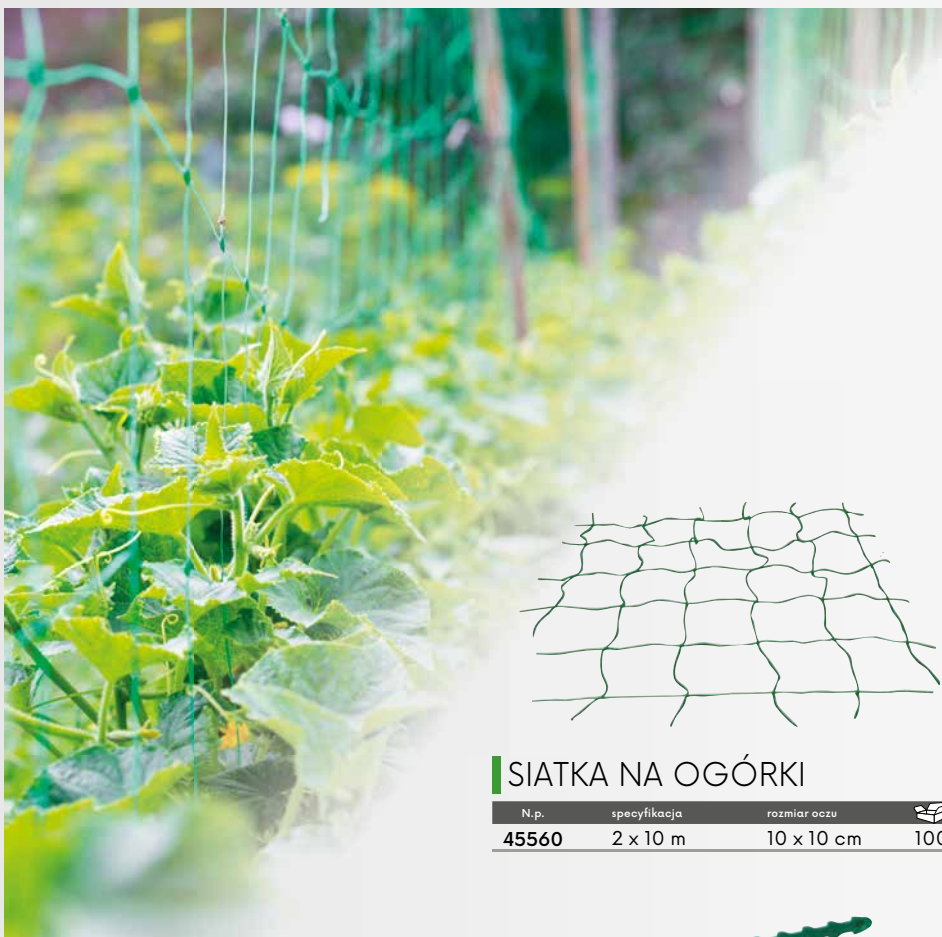

SIATKA NA OGÓRKI

N.p.	specyfikacja	rozmiar oczu	
45560	2 x 10 m	10 x 10 cm	100

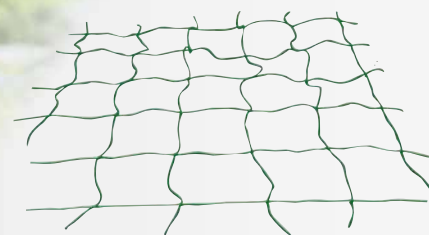

TYCZKA WŁÓKNO SZKLANE

N.p.	specyfikacja	
45036	180 cm Ø 7,9 mm	100

PASKI DO WIAZANIA Z ZĄBKAMI

50x

N.p.	specyfikacja	
23840		20



TYCZKA OGRODNICZA

N.p.	specyfikacja		N.p.	specyfikacja		N.p.	specyfikacja	
45650	90 cm Ø 8 mm	25	45655	150 cm Ø 11 mm	25	45659	180 cm Ø 16 mm	25
45651	120 cm Ø 8 mm	25	45656	180 cm Ø 11 mm	25	45660	210 cm Ø 16 mm	25
45652	150 cm Ø 8 mm	25	45661	210 cm Ø 11 mm	25	45662	150 cm Ø 20 mm	10
45653	90 cm Ø 11 mm	25	45657	120 cm Ø 16 mm	25	45663	180 cm Ø 20 mm	10
45654	120 cm Ø 11 mm	25	45658	150 cm Ø 16 mm	25	45664	210 cm Ø 20 mm	10



TYCZKA DO POMIDORÓW

N.p.	specyfikacja	
44041	1,2 m, Ø 5,5 mm komaxit - zielony	10
44042	1,5 m, Ø 6 mm komaxit - zielony	10
44043	1,8 m, Ø 6 mm komaxit - zielony	10
45049	1,8 m, Ø 7 mm komaxit - zielony	10
45044	1,8 m, Ø 7 mm komaxit - srebrny	10
44050	2,2 m, Ø 7 mm komaxit - zielony	10

SPÓJNIK PLASTIKOWY

N.p.	specyfikacja	
45670	8 mm	10
45671	11 mm	10
45672	16 mm	10
45673	20 mm	10



MOQ
10



TASMA WIĄŻĄCA, RZEP



N.p.	specyfikacja	
45471	12 mm x 5 m	1



DRUT DO WIĄZANIA PVC



N.p.	specyfikacja	
45043	30 m	30



DRUT DO WIĄZANIA PVC

N.p.	specyfikacja	
23845	3 mm x 8 m	30
23846	4 mm x 6 m	30
23847	5 mm x 4 m	30



TASMA WIĄŻĄCA

3x



N.p.	specyfikacja	
45472	3 cm x 3 m, 3 szt	36



TASMA WIĄŻĄCA



N.p.	specyfikacja	
45473	3 cm x 50 m	60

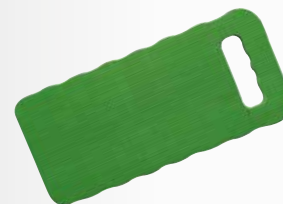

PODKŁADKA

N.p.	specyfikacja	
45086	40 x 18 x 2 cm	50



STÓŁEK OGRODOWY, SKŁADANY

· for sitting and upside down for kneeling



N.p.	specyfikacja	
45074	58 x 48 x 28 cm	4



KOSZ OGRODOWY SKŁADANY

N.p.	specyfikacja	
45093	40 x 25 x 23 cm	10



KOSZ POJEMNIK ELASTYCZNY OGRODOWY



N.p.	specyfikacja	
39192	26 l	20
39193	42 l	20



SKŁADANY KOSZ NA LIŚCIE PE

N.p.	specyfikacja	
45047	55 x 70 cm, 3 drzadzla	20



SKŁADANY KOSZ NA LIŚCIE PE

N.p.	specyfikacja	
44960	200 l 60 x 60 x 55 cm	50

FESTA[®] AQUATIC



FESTA[®]
AQUATIC

PISTOLET ZRASZAJACY

- 7 funkcji
- przedni spust z blokadą
- łatwa kontrola przepływu



N.p. specyfikacja
45386

12



FESTA[®]
AQUATIC

PISTOLET ZRASZAJACY

- regulowany przepływ
- przedni spust z blokadą
- łatwa kontrola przepływu



N.p. specyfikacja
45388

12



FESTA[®]
AQUATIC

ZRASZACZ

- regulowany przepływ



N.p. specyfikacja
45389

24



FESTA[®]
AQUATIC

ZESTAW Z PISTOLETEM

- regulowany przepływ



N.p. specyfikacja
45385

4 szt

12



FESTA[®]
AQUATIC

ZŁĄCZE



1/2" N.p. specyfikacja
45390

24



FESTA[®]
AQUATIC

SZYBKOZŁĄCZKA



1/2" N.p. specyfikacja
45392

24



FESTA[®]
AQUATIC

STOP SZYBKOZŁĄCZKA



1/2" N.p. specyfikacja
45394

24

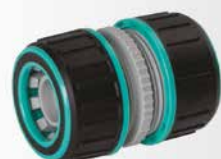

FESTA[®]
AQUATIC

ZŁĄCZE



3/4" N.p. specyfikacja
45391

24



FESTA[®]
AQUATIC

SZYBKOZŁĄCZKA



3/4" N.p. specyfikacja
45393

24



FESTA[®]
AQUATIC

STOP SZYBKOZŁĄCZKA



3/4" N.p. specyfikacja
45395

24

FESTA
AQUATIC
ADAPTER



N.p. specyfikacja
45396 24



NEW

FESTA
AQUATIC
WAŻ OGRODOWY
PROFI



N.p.	specyfikacja	
45372	1/2" 25 m	1
45373	1/2" 50 m	1
45374	3/4" 25 m	1
45375	3/4" 50 m	1
45376	1" 25 m	1
45377	1" 50 m	1



FESTA
AQUATIC
ZRASZACZ WAHADTOWY

· 19 dysz, z czego 8 przełączalnych



N.p. specyfikacja
45398 6

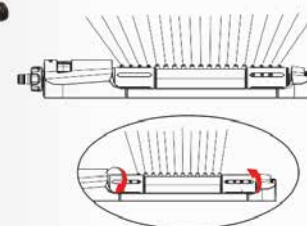

FESTA
AQUATIC
ZRASZACZ

· regulowane ramiona z dyszami



N.p. specyfikacja
45399 12



FESTA
AQUATIC
ROZDZIELACZ
OGRODOWY

· regulowany przepływ



N.p. specyfikacja
45400 6



FESTA
AQUATIC
ROZDZIELACZ
OGRODOWY

· regulowany przepływ



N.p. specyfikacja
45401 6



ROSA**PISTOLET
ZRASZAJĄCY**

- 10 funkcji
- przedni spust z blokadą

0,7bar min
5,5bar max

N.p. specyfikacja

45124



12

**ROSA****PISTOLET
ZRASZAJĄCY**

- 10 funkcji
- spust z blokadą
- łatwa kontrola przepływu

0,7bar min
5,5bar max

N.p. specyfikacja

45125



12

**ROSA**

Watering system

**ROSA****PISTOLET
ZRASZAJĄCY**

- 7 funkcji
- spust z blokadą

0,7bar min
5,5bar max

N.p. specyfikacja

45126



12

ROSA**PISTOLET
ZRASZAJĄCY**

- 7 funkcji
- spust z blokadą
- łatwa kontrola przepływu

0,7bar min
5,5bar max

N.p. specyfikacja
metalowa

45123



12

**ROSA****PISTOLET
ZRASZAJĄCY**

- 6 funkcji
- spust z blokadą
- łatwa kontrola przepływu

0,7bar min
5,5bar max

N.p. specyfikacja

45117



12

**ROSA****PISTOLET
ZRASZAJĄCY**

- 6 funkcji
- spust z blokadą
- łatwa kontrola przepływu

0,7bar min
5,5bar max

N.p. specyfikacja
metalowa główka

45118



12

**ROSA****PISTOLET
ZRASZAJĄCY**

- 5 funkcji
- spust z blokadą
- łatwa kontrola przepływu

0,7bar min
5,5bar max

N.p. specyfikacja

45110



12

**ROSA****PISTOLET
ZRASZAJĄCY**

- z sitkiem
- łatwa kontrola przepływu

0,7bar min
5,5bar max

N.p. specyfikacja

45116



12



ROSA

PISTOLET ZRASZAJĄCY

- metalowa głowa
- spust z blokadą
- łatwa kontrola przepływu

0,7 bar min
5,5 bar max

N.p. specyfikacja
45120



12

ROSA

PISTOLET ZRASZAJĄCY

- metal
- spust z blokadą
- łatwa kontrola przepływu

0,7 bar min
5,5 bar max

N.p. specyfikacja
45122 metalowa



12

ROSA

PISTOLET ZRASZAJĄCY

- spust z blokadą
- łatwa kontrola przepływu

0,7 bar min
5,5 bar max

N.p. specyfikacja
45111



12

ROSA

KOŃCÓWKA ZRASZACZA

- regulowany przepływ

10 bar max

1"

N.p. specyfikacja
45214



48

ROSA

ZRASZACZ

- klasyczne połączenie

0,7 bar min
5,5 bar max

N.p. specyfikacja
45112



32

ROSA

ZRASZACZ

- regulowany przepływ

0,7 bar min
5,5 bar max

N.p. specyfikacja
45113



60

ROSA

PISTOLET ZRASZAJĄCY

- spust z blokadą
- łatwa kontrola przepływu

0,7 bar min
5,5 bar max

N.p. specyfikacja
45115



12

ROSA

PISTOLET ZRASZAJĄCY ZESTAW

- spust z blokadą
- łatwa kontrola przepływu

0,7 bar min
5,5 bar max

1/2" 2x

N.p. specyfikacja
45114 1/2 szybkozłączka



12

ROSA

PISTOLET ZRASZAJĄCY ZESTAW

- 6 funkcji
- spust z blokadą
- łatwa kontrola przepływu

0,7 bar min
5,5 bar max

1/2" 4x

N.p. specyfikacja
45181



12



ROSA

ZESTAW Z PISTOLETEM

- regulowany przepływ

0,7 bar min
5,5 bar max

1/2" 4x

N.p. specyfikacja
45180



12

ROSA
ZŁĄCZE



N.p. specyfikacja 60
45140

ROSA
SZYBKOZŁĄCZKA



N.p. specyfikacja 60
45142

ROSA
STOP
SZYBKOZŁĄCZKA



N.p. specyfikacja 60
45138

ROSA
ZŁĄCZE



MOQ 20

N.p. specyfikacja 60
45296

ROSA
SZYBKOZŁĄCZKA



MOQ 20

N.p. specyfikacja 60
45298

ROSA
STOP
SZYBKOZŁĄCZKA



MOQ 20

N.p. specyfikacja 60
45294

ROSA
ZŁĄCZE



N.p. specyfikacja 60
45141

ROSA
SZYBKOZŁĄCZKA



N.p. specyfikacja 60
45143

ROSA
STOP
SZYBKOZŁĄCZKA



N.p. specyfikacja 60
45139

ROSA
ZŁĄCZE



MOQ 20

N.p. specyfikacja 60
45297

ROSA
SZYBKOZŁĄCZKA



MOQ 20

N.p. specyfikacja 60
45299

ROSA
STOP
SZYBKOZŁĄCZKA



MOQ 20

N.p. specyfikacja 60
45295

ROSA
REDUKCJA 1/2" - 3/4"



N.p. specyfikacja 60
45213

ROSA
REDUKCJA



N.p. specyfikacja 48
45216

ROSA
ZŁĄCZE



N.p. specyfikacja 48
45218

ROSA
ADAPTER



10 bar max	1/2"	3/4"	1"
N.p.	specyfikacja		
45130	1/2" + 3/4"		60
45131	3/4" + 1"		60

ROSA
ADAPTER



10 bar max	1"	3/4"	1"
N.p.	specyfikacja		
45217			48

ROSA
SZYBKOZŁĄCZKA



10 bar max	1"
N.p.	specyfikacja
45219	

ROSA
ADAPTER



10 bar max	1/2"	3/4"	1"	MOQ 20
N.p.	specyfikacja			
45289	1/2" + 3/4"			MOQ 20
45290	3/4" + 1"			MOQ 20

ROSA
SZYBKOZŁĄCZKA SADA



2x	10 bar max	1/2"	3/4"
N.p.	specyfikacja		
45144			60

ROSA
ZAWÓR ŁĄCZĄCY z zaworem



6,9 bar max	3/4"
N.p.	specyfikacja
45135	

ROSA
ADAPTER



10 bar max	3/4"
N.p.	specyfikacja
45133	

ROSA
ADAPTER



10 bar max	3/4"
N.p.	specyfikacja
45132	

ROSA
ADAPTER



10 bar max	
N.p.	specyfikacja
45136	

ROSA
ADAPTER



10 bar max	3/4"	MOQ 20
N.p.	specyfikacja	
45292		MOQ 20

ROSA
ADAPTER



10 bar max	3/4"	MOQ 20
N.p.	specyfikacja	
45291		MOQ 20

ROSA
ADAPTER



10 bar max	MOQ 20
N.p.	specyfikacja
45293	

ROSA
ADAPTER



10 bar max	
N.p.	specyfikacja
45137	

ROSA
ADAPTER



10 bar max	1"
N.p.	specyfikacja
45215	

ROSA
ADAPTER



10 bar max	1/2"
N.p.	specyfikacja
45145	

ROSA

ROZDZIELACZ Y

z zaworem wody

0,7 bar min
5,5 bar max

N.p. specyfikacja

45134



12



3/4"

ROSA

ZESTAW - DISPLAY BOX

skład zestawu

45113	15 szt.	kom
45117	10 szt.	kom
45120	15 szt.	kom
45132	40 szt.	kom
45131	40 szt.	kom
45133	40 szt.	kom
45142	25 szt.	kom
45143	20 szt.	kom
45140	20 szt.	kom

225x

N.p. specyfikacja

45146



1



ROSA

ZRASZACZ

impulsowy

0,7 bar min
5,5 bar max

N.p. specyfikacja

45162



24



ROSA

ZRASZACZ

8 funkcji

0,7 bar min
5,5 bar max

N.p. specyfikacja

45154



48



ROSA

ZRASZACZ

rotacyjny
2 ramiona0,7 bar min
5,5 bar max

N.p. specyfikacja

45153



24



ROSA

ZRASZACZ

rotacyjny
3 ramiona0,7 bar min
5,5 bar max

N.p. specyfikacja

45152



24



ROSA

ZRASZACZ

17 otworów, aluminiuj

0,7 bar min
5,5 bar max

ALU

N.p. specyfikacja

45158



6

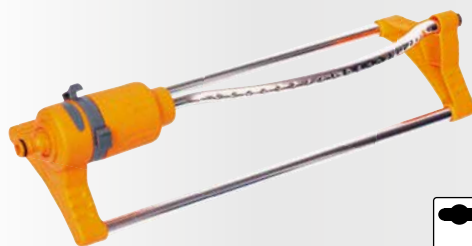

ROSA

ZRASZACZ

piramidalny

0,7 bar min
5,5 bar max

N.p. specyfikacja

45167



12



ROSA

STOJAK DO
ZRASZACZY
IMPULSOWYCH0,7 bar min
5,5 bar max

3/4"

N.p. specyfikacja

45155



24



ROSA

ZRASZACZ
IMPULSOWY

na trójnogu

0,7 bar min
5,5 bar maxN.p. specyfikacja
impulse, tronożac

45163



20



ROSA

ZRASZACZ

· wbijany

0,7 bar min
5,5 bar max

N.p. specyfikacja

45160 25



ROSA

ZRASZACZ

· zraszacz sitko z zaworem

0,7 bar min
5,5 bar max

N.p. specyfikacja

45156 12



ROSA

LICZNIK DO WODY

· 0 - 120 min.

0,7 bar min
5,5 bar max

3/4"

N.p. specyfikacja

45147 24



ROSA

**ZRASZACZ
IMPULSOWY**

· mosiądz

0,7 bar min
5,5 bar max

3/4"

N.p. specyfikacja

45150 12



ROSA

ZRASZACZ IMPULSOWY

0,7 bar min
5,5 bar max

3/4"

N.p. specyfikacja

45151 12



ROSA

**ZRASZACZ
IMPULSOWY**

0,7 bar min
5,5 bar max

3/4"

N.p. specyfikacja

45168 wbijany stojak plastikowy 12
45169 wbijany stojak metalowy 12



ROSA

**ZRASZACZ
IMPULSOWY**

0,7 bar min
5,5 bar max

N.p. specyfikacja

45161 plastový hrot 20



ROSA

**ZRASZACZ
ROTACYJNY**

· 3 ramiona

0,7 bar min
5,5 bar max

3/4"

N.p. specyfikacja

45164 wbijany stojak plastikowy 12



ROSA

**WBIJANY
STOJAK**

3/4" Zn

N.p. specyfikacja

45159 12



ROSA

WBIJANY STOJAK

3/4"

N.p. specyfikacja

45179 12



ROSA

PROWADNICA WĘŻA

N.p. specyfikacja

45186 48



ROSA

**ZRASZACZ
IMPULSOWY**

1"

N.p. specyfikacja

45185 20



ROSA

**ZRASZACZ
IMPULSOWY**

3/4"

N.p. specyfikacja

45184 20



ROSA

ZŁĄCZE
MOSIĄDZ



N.p. specyfikacja
45192



48

ROSA

SZYBKOZŁĄCZKA
MOSIĄDZ



N.p. specyfikacja
45194



48

ROSA

STOP
SZYBKOZŁĄCZKA
MOSIĄDZ

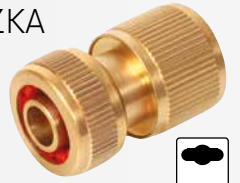

N.p. specyfikacja
45190



48

ROSA

ZŁĄCZE
MOSIĄDZ

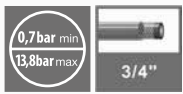

N.p. specyfikacja
45193



48

ROSA

SZYBKOZŁĄCZKA
MOSIĄDZ



N.p. specyfikacja
45195



48

ROSA

STOP
SZYBKOZŁĄCZKA
MOSIĄDZ



N.p. specyfikacja
45191



48

ROSA

ADAPTER
MOSIĄDZ



N.p. specyfikacja
45196 z gwintem wewnętrznym 1/2" + 3/4" 48



48

ROSA

ADAPTER
MOSIĄDZ



N.p. specyfikacja
45197 z gwintem wewnętrznym 3/4" 48



48

ROSA

ADAPTER
MOSIĄDZ



N.p. specyfikacja
45199 z gwintem wewnętrznym 1" 48



48

ROSA

ADAPTER
MOSIĄDZ



N.p. specyfikacja
45198 z gwintem wewnętrznym 3/4 + 1" 48



48

ROSA

ADAPTER
MOSIĄDZ



N.p. specyfikacja
45200 z gwintem wewnętrznym 3/4 48



48

ROSA

KONCÓWKA
ZRASZACZA
MOSIĄDZ



N.p. specyfikacja
45206 regulowany przepływ 48



48

ROSA

ADAPTER
MOSIĄDZ



N.p. specyfikacja
45203 na 2 szybkozłączki 48



48

ROSA

ADAPTER
MOSIĄDZ



N.p. specyfikacja
45204 na 3 szybkozłączki 48



48

SZYBKOZŁĄCZKA
MOSIĄDZ



N.p. specyfikacja
45211 1", watek 1" 25



25

ROSA

ZESTAW USZCZELEK

· zestaw
45110, 45111, 45118, 45120, 45121, 45123,
45125, 45126, 45130, 45131, 45132, 45134,
45135, 45152, 45153, 45154, 45155, 45156,
45162, 45177, 45178, 45180, 45196, 45197,
45198



N.p. specyfikacja
45175 1

ROSA

USZCZELKA

50x

N.p. specyfikacja
45187 1



NEW



ROSA

WĄŻ OGRODOWY CZYSTY



N.p.	specyfikacja	
45342	1/2" 10 m	1
45343	1/2" 15 m	1
45344	1/2" 20 m	1
45345	1/2" 25 m	1
45346	1/2" 50 m	1
45341	3/4" 10 m	1
45347	3/4" 15 m	1
45348	3/4" 20 m	1
45349	3/4" 25 m	1
45351	3/4" 50 m	1
45352	1" 15 m	1
45353	1" 25 m	1
45354	1" 50 m	1

NEW



FESTA AQUATIC

WĄŻ OGRODOWY PROFI



N.p.	specyfikacja	
45372	1/2" 25 m	1
45373	1/2" 50 m	1
45374	3/4" 25 m	1
45375	3/4" 50 m	1
45376	1" 25 m	1
45377	1" 50 m	1



ROSA

WĄŻ SPIRALA



N.p.	specyfikacja	
45300	7,5 m	6
45301	15 m	8



ROSA

NAWIJAK DO WĘŻA



N.p.	specyfikacja	
45178	1/2" 60 m	5



ROSA

WÓZEK NA WĄŻ



N.p.	specyfikacja	
45183	1/2" 60 m	5



ROSA

WÓZEK NA WĄŻ



N.p.	specyfikacja	
45177	1/2" 60 m	5

ROSA

NAWIJAK DO WĘŻA



N.p.	specyfikacja		
45182	1/2" 40 m	4	60

ROSA

NAWIJAK DO WĘŻA

• waz w zestawie 1/2" 20 m



N.p.	specyfikacja		
45176		1	60



ROSA

UCHWYT WĘŻA

N.p.	specyfikacja	
45174		60



UCHWYT NA WĄŻ

• max. 30 m, 1/2" plastikowa rura ogrodowa,

N.p.	specyfikacja	
45350	Max. ładowność 20 kg	1



ZŁĄCZE DO WĘŻA

N.p.	specyfikacja	
45220	1/2" watek 3/4"	10
45221	3/4" watek 1"	10
45222	1" watek 1"	10



KOŃCÓWKA WĘŻA

N.p.	specyfikacja	
45223	1/2" watek 3/4"	10
45224	3/4" watek 1"	10
45225	1" watek 1"	10



ZŁĄCZE DO WĘŻA

N.p.	specyfikacja	
45226	1/2" - 3/4" watek 1"	10
45227	1" - 3/4" watek 1"	10
45228	1" - 1/2" watek 1"	10



KOŃCÓWKA ZRASZACZA

N.p.	specyfikacja	
45229		10



N.p.	średnica	
45603	16 - 25 mm	2
45604	20 - 32 mm	2
45605	25 - 40 mm	2
45606	30 - 45 mm	2
45607	32 - 50 mm	2
45608	40 - 60 mm	2
45609	50 - 70 mm	2
45610	60 - 80 mm	2
45611	70 - 90 mm	2
45612	80 - 100 mm	2
45613	90 - 110 mm	2
45614	100 - 120 mm	2
45615	110 - 130 mm	2
45616	120 - 140 mm	2
45617	130 - 150 mm	2
45618	140 - 160 mm	2
45619	150 - 170 mm	2



N.p.	średnica	szerokość	
45623	16 - 25 mm	9 mm	2
45624	20 - 32 mm	9 mm	2
45625	25 - 40 mm	12 mm	2
45626	30 - 45 mm	12 mm	2
45627	32 - 50 mm	12 mm	2
45628	40 - 60 mm	12 mm	2
45629	50 - 70 mm	12 mm	2
45630	60 - 80 mm	12 mm	2
45631	70 - 90 mm	12 mm	2
45632	80 - 100 mm	12 mm	2
45633	90 - 110 mm	12 mm	2
45634	100 - 120 mm	12 mm	2
45635	110 - 130 mm	12 mm	2
45636	120 - 140 mm	12 mm	2
45637	130 - 150 mm	12 mm	2
45638	140 - 160 mm	12 mm	2
45639	150 - 170 mm	12 mm	2

OPASKA ZACISKOWA WĘŻA

N.p.	średnica	
45600	8 - 12 mm	2
45601	10 - 16 mm	2
45602	12 - 20 mm	2

Zn

MOQ
2

OPASKA ZACISKOWA WĘŻA

N.p.	średnica	szerokość	
45620	8 - 12 mm	9 mm	2
45621	10 - 16 mm	9 mm	2
45622	12 - 20 mm	9 mm	2

INOX

MOQ
2

ZAWÓR OGRODOWY

N.p.	
45105	8



ZAWÓR OGRODOWY

N.p.	specyfikacja	
45100	1/2"	12
45101	3/4"	10
45102	1"	6



ZAWÓR KULOWY

N.p.	specyfikacja	
45106	1/2"	12
45107	3/4"	10
45108	1"	8



KONEWKA

MADE IN
EU

N.p.	specyfikacja	
45280	2,5 l	10
45283	5 l	10
45285	10 l	10
45286	12 l	10
45287	15 l	10



ZAWÓR NAROŻNY

N.p.	specyfikacja	
45104	1/2" x 3/8"	10





FESTA

OPRYSKIWACZ CIŚNIENIOWY

maszt. ciśnienie	2,5 Bar
objętość	12 l
długość węża	3 m
wymiary:	32 x 25 x 59 cm



N.p.	specyfikacja	
45249	opryskiwacz ciśnienia 12 l	1

FESTA

OPRYSKIWACZ CIŚNIENIOWY

N.p.	specyfikacja	
45247	12 l	1
45248	16 l	1



N.p.	specyfikacja	
45263	zapasowy waz	1
45251	zapasowy zestaw uszczelnień	1
45254	zapasowa dysza	1
45257	zapasowa uchwyć	1
45261	zapasowa pret - 370 mm	1
45267	zapasowa pret 45 - 250 cm	1
45268	zapasowa pret 65 - 260 cm	1

FESTA

OPRYSKIWACZ CIŚNIENIOWY

N.p.	specyfikacja	
45244	3 l	6
45245	5 l	6
45246	8 l	6



N.p.	specyfikacja	
45262	zapasowy waz	1
45250	zapasowy zestaw uszczelnień	1
45253	zapasowa dysza	1
45256	zapasowa uchwyć	1
45260	zapasowa pret - 370 mm	1

• nadaje się do 45244, 45245, 45246



• nadaje się do 45247, 45248

93 - 250 cm



TELESKOPOWY DRAŻEK DO OPRYSKIWACZA

N.p.	typ		
45267	45 - 250 cm	inox	1
45268	65 - 260 cm	fiberglass	1

TELESKOPOWY DRAŻEK DO OPRYSKIWACZA

N.p.	specyfikacja	
45269		1



WĄŻ ZAPASOWY DO OPRYSKIWACZA

N.p.	typ	
45263	za drażek 45247, 45248	1
45262	za drażek 45244, 45245, 45246	1



OSŁONA HERBICYDOWA

N.p.	wielkość	długość	szerokość	wysokość	
45265	mała	230 mm	90 mm	130 mm	1
45266	duża	370 mm	140 mm	200 mm	1



FESTA

**OPRYSKIWACZ
RECZNY
CIŚNIENIOWY**



N.p.	typ	
45242	1,5 l	20
45241	2 l	20

OPRYSKIWACZ



N.p.	typ	
45239	0,5 l	1
45240	0,7 l	1



ROSA
PRYSZNIC



N.p.	specyfikacja	
45171	nastawny	12



ROSA
PRYSZNIC



N.p.	specyfikacja	
45170	statyw	6



ROSA
PRYSZNIC



N.p.	specyfikacja	
45172	z zaworem	12
45173	10 funkcji	12



FESTA®

system click
ON - OFF

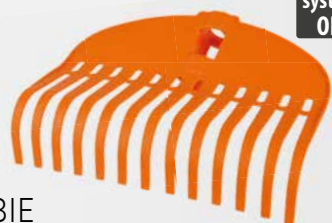

system click
ON - OFF



system click
ON - OFF

FESTA®

PLASTIKOWE GRABIE

N.p.	počet lamel	szerokość	wysokość	
45327	13	240 mm	200 mm	12

FESTA®

PLASTIKOWE GRABIE

N.p.	počet lamel	szerokość	
45325	12	410 mm	12

system click
ON - OFF



FESTA®

PLASTIKOWE GRABIE

N.p.	počet lamel	szerokość	wysokość	
45328	23	480 mm	280 mm	12

system click
ON - OFF



FESTA®

PLASTIKOWE GRABIE

N.p.	počet lamel	szerokość	
45326	18	580 mm	12

system click
ON - OFF



FESTA®

PLASTIKOWE GRABIE

N.p.	počet lamel	szerokość	wysokość	
45329	35	760 mm	310 mm	1

system click
ON - OFF



FESTA®

MIOTŁA ULICZNA

N.p.	specyfikacja	
45323	37 cm	16

FESTA®

UCHWYT ALU

ALU

N.p.	specyfikacja	
45330	161 cm	24
45331	100 cm	24



system click
ON - OFF

**FESTA**

METALOWY GRABEK REGULOWANY



Zn

N.p.	počet lamel	rozsah	
44965	15	200 - 590 mm	12

METALOWY GRABEK REGULOWANY



Zn

N.p.	počet lamel	váha	rozsah	
45050	15	1200 g	200 - 590 mm	25

FESTA

GRABIE METALOWE - BLASZKI

· stal sprężynowa



N.p.	szerość	počet lamel	
45071	55 cm	22	1

FESTA

METALOWE GRABIE Z RĄCZKĄ

MOQ
3

N.p.	szerość	długość niasady	
61150	55 cm	160 cm	3



GRABIE METALOWE - BLASZKI

N.p.	szerość	počet lamel	
45051	40 cm	22	60

METALOWE GRABIE Z RĄCZKĄ

MOQ
3

N.p.	szerość	długość niasady	
61130	40 cm	160 cm	3



METALOWE GRABIE - DRUT

N.p.	szerość	počet lamel	
45052	45 cm	22	36

METALOWE GRABIE Z RĄCZKĄ

MOQ
3

N.p.	szerość	długość niasady	
61131	45 cm	160 cm	3

PLASTIKOWE GRABIE



N.p.	szerokość	počet lamel	
45320	60 cm	24	10

PLASTIKOWE GRABIE Z UCHWYTEM



N.p.	szerokość	počet lamel	długość násady	
61132	60 cm	24	160 cm	3

MOQ
3

PLASTIKOWE GRABIE



N.p.	szerokość	počet lamel	
45055	50 cm	22	10

PLASTIKOWE GRABIE Z UCHWYTEM



N.p.	szerokość	počet lamel	długość násady	
61133	50 cm	22	160 cm	3

MOQ
3

PLASTIKOWE GRABIE



N.p.	szerokość	počet lamel	
45321	40 cm	23	20

PLASTIKOWE GRABIE Z UCHWYTEM



N.p.	počet lamel	długość násady	
61134	23	160 cm	3

MOQ
3

PLASTIKOWE GRABIE



N.p.	szerokość	počet lamel	
45054	40 cm	23	10

PLASTIKOWE GRABIE Z UCHWYTEM



N.p.	szerokość	počet lamel	długość násady	
61135	40 cm	23	160 cm	3

MOQ
3

PLASTIKOWE GRABIE



N.p.	szerokość	počet lamel	
45053	58 cm	16	35

PLASTIKOWE GRABIE Z UCHWYTEM



N.p.	szerokość	počet lamel	długość násady	
61141	58 cm	16	160 cm	3

MOQ
3

PLASTIKOWE GRABIE Z KRAWĘDZIĄ WYRÓWNANIA



N.p.	szerokość	počet zubů	
45070	41 cm	14	4

PLASTIKOWE GRABIE - Z KRAWĘDZIĄ WYRÓWNANIA - Z UCHWYTEM



MOQ
3

N.p.	szerokość	počet zubů	długość niasady	
61142	41 cm	14	160 cm	3

METALOWE GRABIE

N.p.	szerokość	počet zubů	
61030	24 cm	10	24
61031	29 cm	12	24
61032	34 cm	14	24
61033	40 cm	16	24



METALOWE GRABIE Z UCHWYTEM

N.p.	szerokość	počet zubů	długość niasady	
61060	24 cm	10	160 cm	3
61061	29 cm	12	160 cm	3
61062	34 cm	14	160 cm	3
61063	40 cm	16	160 cm	3



MOQ
3

NACHYLENIE WERTYKALNE

· młotkowa farba

N.p.	szerokość	počet zubů	
61045	30 cm	12	25
61046	39 cm	14	25
61047	45 cm	16	25



NACHYLENIE WERTYKALNE Z UCHWYTEM

· młotkowa farba

N.p.	szerokość	počet zubů	długość niasady	
61143	30 cm	12	160 cm	3
61144	39 cm	14	160 cm	3
61145	45 cm	16	160 cm	3



MOQ
3

NACHYLENIE WERTYKALNE

N.p.	szerokość	počet zubů	
61048	35 cm	11 21	12



METALOWE GRABIE Z UCHWYTEM

N.p.	szerokość	počet zubů	długość niasady	
61146	35 cm	11 21	160 cm	3



MOQ
3

METALOWE GRABIE Z UCHWYTEM, FIBERGLASS

N.p.	szerokość	počet zubů	długość niasady	
61034	34 cm	14	160 cm	3



MOQ
3



FESTA

SZPADEL OSTRY

N.p.	specyfikacja	długość niasady	
61006	19 x 28 cm	120 cm	5



FESTA

SZPADEL OSTRY

• nadaje się do pracy w szklarni

N.p.	specyfikacja	długość niasady	
61008	19 x 28 cm	85 cm	5



FESTA

SZPADEL PROSTY

N.p.	specyfikacja	długość niasady	
61005	20 x 29 cm	120 cm	5



FESTA



FESTA

SZPADEL PROSTY - ROZSZERZONY

• dla osób o wzroście powyżej 180 cm

N.p.	specyfikacja	długość niasady	
61157	20 x 29 cm	130 cm	5

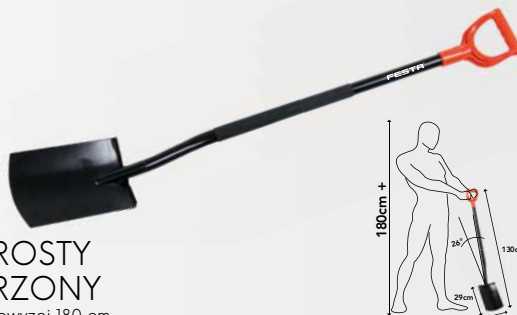

FESTA

SZPADEL OSTRY - ROZSZERZONY

• dla osób o wzroście powyżej 180 cm

N.p.	specyfikacja	długość niasady	
61158	19 x 28 cm	130 cm	5



FESTA

ŁOPATA STANDARD

N.p.	specyfikacja	długość niasady	
61155	24 x 29 cm	120 cm	5



FESTA

WIDŁY

N.p.	specyfikacja	długość niasady	
61156	19 x 28 cm	130 cm	5



FESTA

WIDŁY DO KOPANIA

N.p.	specyfikacja	długość niasady	
61007	18 x 28 cm	130 cm	5



RYCÍ WIDŁY, UCHWYT FIBERGLASS

N.p.	specyfikacja	długość niasady	
61010	18 x 30 cm	95 cm	12



SZPADEL SZPICZASTY FIBERGLASS

N.p.	specyfikacja	długość niasady	
61029	19 x 30 cm	105 cm	12



SZPADEL FIBERGLASS

N.p.	specyfikacja	długość niasady	
61015	19 x 30 cm	105 cm	12





ŁOPATA ALU Z UCHWYTEM

· trzon bukowy

ALU

MOQ
3

N.p.	specyfikacja	długość niasady	
61057	26 x 29 cm	130 cm	3
61056	34 x 30 cm	130 cm	3



ŁOPATA ALU

ALU

N.p.	specyfikacja	
61026	26 x 29 cm	10
61025	34 x 30 cm	10



ŁOPATA Z UCHWYTEM

MOQ
3

N.p.	specyfikacja	długość niasady	
61089	35 x 35 cm	130 cm	3



ŁOPATA DO WĘGLA

N.p.	specyfikacja	
61021	35 x 35 cm	10



ŁOPATA SERCOWA Z UCHWYTEM

· młotkowa farba
· trzon bukowy

MOQ
3

N.p.	specyfikacja	długość niasady	
61050	26 x 28 cm	130 cm	3

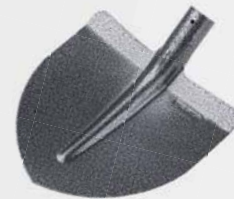

ŁOPATA SERCOWA

· młotkowa farba

N.p.	specyfikacja	
61000	26 x 28 cm	12



ŁOPATA SERCOWA Z UCHWYTEM

· trzon bukowy
· bukowa rućka

MOQ
3

N.p.	specyfikacja	długość niasady	
61088	26 x 28 cm	130 cm	3



ŁOPATA SERCOWA

N.p.	specyfikacja	
61020	26 x 28 cm	12



ŁOPATA STANDARD Z UCHWYTEM

· młotkowa farba
· trzon bukowy

MOQ
3

N.p.	specyfikacja	długość niasady	
61051	24 x 29 cm	130 cm	3



ŁOPATA STANDARD

· młotkowa farba

N.p.	specyfikacja	
61001	24 x 29 cm	12





ŁOPATA STANDARD

N.p.	specyfikacja	
61022	24 x 29 cm	12



ŁOPATA STANDARD Z UCHWYTEM

• trzon bukowy

MOQ
3

N.p.	specyfikacja	długość niasady	
61090	24 x 29 cm	130 cm	3
61053	24 x 29 cm	130 cm "T", uchwyt	3



ŁOPATA HOLŠTÝNSKÁ

N.p.	specyfikacja	
61058	25 x 27 cm	12



ŁOPATA HOLŠTÝNSKÁ Z UCHWYTEM

• trzon bukowy

MOQ
3

N.p.	specyfikacja	długość niasady	
61059	25 x 27 cm	130 cm	3



ŁOPATA WĄSKA

• młotkowa farba

N.p.	specyfikacja	
61002	19 x 27 cm	12



ŁOPATA WĄSKA Z UCHWYTEM

• młotkowa farba
• trzon bukowy

MOQ
3

N.p.	specyfikacja	długość niasady	
61052	19 x 27 cm	130 cm	3



ŁOPATA WĄSKA

N.p.	specyfikacja	
61024	19 x 27 cm	12



ŁOPATA WĄSKA Z UCHWYTEM

MOQ
3

N.p.	specyfikacja	długość niasady	
61054	19 x 27 cm	130 cm	3



PLASTIKOWA ŁOPATA

N.p.	specyfikacja	
61027	24 x 26 cm	12



SZPADEL Z "T" UCHWYTEM

· młotkowa farba

MOQ
3

N.p.	specyfikacja	długość niasady	MOQ
61161	22 x 30 cm	90 cm	3



SZPADEL SZPICZASTY

· młotkowa farba

N.p.	specyfikacja	MOQ
61004	22 x 30 cm	12



SZPADEL SPICZASTY Z "T" UCHWYTEM

MOQ
3

N.p.	specyfikacja	długość niasady	MOQ
61097	19 x 30 cm	90 cm	3



SZPADEL SPICZASTY

N.p.	specyfikacja	MOQ
61019	22 x 30 cm	12



SZPADEL SPICZASTY Z "T" UCHWYTEM

N.p.	specyfikacja	długość niasady	MOQ
61162	22 x 25 cm	90 cm	3
61223	uchwyt	90 cm	1



SZPADEL SPICZASTY

N.p.	specyfikacja	MOQ
61013	22 x 25 cm	12



SZPADEL Z "T" UCHWYTEM

· młotkowa farba

MOQ
3

N.p.	specyfikacja	długość niasady	MOQ
61163	21 x 30 cm	90 cm	3



SZPADEL

· młotkowa farba

N.p.	specyfikacja	MOQ
61003	21 x 30 cm	12



SZPADEL

N.p.	specyfikacja	
61018	21 x 30 cm	12



SZPADEL Z "T,, UCHWYTEM

MOQ
3

N.p.	specyfikacja	długość niasady	
61098	21 x 30 cm	90 cm	3



SZPADEL

N.p.	specyfikacja	
61014	14 x 37 cm	12



SZPADEL Z "T,, UCHWYTEM

N.p.	specyfikacja	długość niasady	MOQ	
61164	14 x 37 cm	90 cm	3	3
61203	uchwyt	90 cm		1



WIDŁY

N.p.	specyfikacja	
61009	20 x 32 cm	12



WIDŁY Z UCHWYTEM

MOQ
3

N.p.	specyfikacja	długość niasady	
61165	20 x 32 cm	90 cm	3



WIDŁY KUTE

N.p.	specyfikacja	
61012	22 x 30 cm	12



WIDŁY KUTE Z "T,, UCHWYTEM

N.p.	specyfikacja	długość niasady	MOQ	
61166	22 x 30 cm	90 cm	3	3
61222	uchwyt	90 cm		1



WIDŁY

N.p.	specyfikacja	
61044	20 x 30 cm	12



WIDŁY Z "T,, UCHWYTEM

N.p.	specyfikacja	długość niasady	MOQ	
61028	20 x 30 cm	90 cm	3	3
61209	uchwyt	90 cm		1



MOTYKA STALOWA, KUTA, Z UCHWYTEM

N.p.	specyfikacja	długość niasady	MOQ	
61111	0,4 kg	120 cm	3	3
61112	0,6 kg	120 cm	3	3
61224	uchwyt	120 cm	1	1

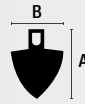

MOTYKA STALOWA, KUTA

N.p.	specyfikacja	A	B	
61035	0,4 kg	180 mm	125 mm	1
61036	0,6 kg	230 mm	160 mm	30



MOTYKA STALOWA, KUTA, Z UCHWYTEM

N.p.	specyfikacja	długość niasady	MOQ	
61114	0,6 kg	120 cm	3	3
61224	uchwyt	120 cm	1	1

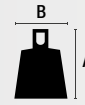

MOTYKA STALOWA, KUTA

N.p.	specyfikacja	A	B	
61038	0,6 kg	165 mm	135 mm	20



MOTYKA Z UCHWYTEM

MOQ
3

N.p.	specyfikacja	długość niasady	
61290	75 mm	120 cm	3
61291	125 mm	120 cm	3
61292	175 mm	120 cm	3

MOTYKA

N.p.	specyfikacja	
61067	75 mm	1
61068	125 mm	1
61069	175 mm	1



MOTYKA Z UCHWYTEM

MOQ
3

N.p.	specyfikacja	długość niasady	
61293	140 mm	120 cm	3

MOTYKA

N.p.	specyfikacja	
61070	140 mm	40



KILOF KUTY Z UCHWYTEM

MOQ
3

N.p.	specyfikacja	długość niasady	
61121	1,5 kg	95 cm	3
61042	2,5 kg	95 cm	3

KILOF KUTY

N.p.	specyfikacja	
61120	1,5 kg	6
61040	2,5 kg	6



FESTA

ŁOPATA DO ŚNIEGU



N.p.	specyfikacja	
60006	46 x 34 cm	12
60206	46 x 34 cm, zmontowano	1

FESTA

ŁOPATA DO ŚNIEGU



N.p.	specyfikacja	
60008	50 x 34 cm	12
60208	50 x 34 cm, zmontowano	1

ŁOPATA DO ŚNIEGU



MADE IN EU

N.p.	specyfikacja	
60001	48 x 40 cm	10
60201	48 x 40 cm, zmontowano	1

ŁOPATA DO ŚNIEGU



ALU

N.p.	specyfikacja	
60012	50 x 38 cm	12
60212	50 x 38 cm, zmontowano	1



SKUWACZ LODU

N.p.	specyfikacja		MOQ
60022	20 cm	3	3

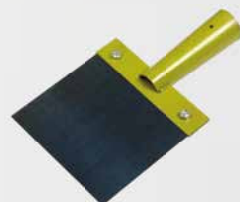

SKUWACZ LODU

N.p.	specyfikacja	
60018	15 cm	20
60019	20 cm	24
60020	30 cm	20
61201	uchwyt 130 cm	10



SÓL DROGOWA

N.p.	specyfikacja	
43300	10 kg	1
43301	25 kg	1



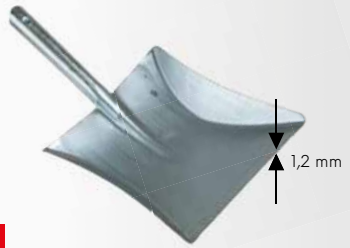

FESTA

STALOWA SZUFELKA - GRUBA

N.p.	specyfikacja	
52176	22 x 23 cm	24

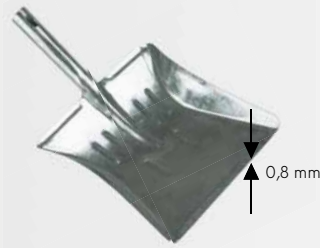

STALOWA SZUFELKA

Zn

N.p.	specyfikacja	
52175	22 x 23 cm	50



SZCZOTKA I SZUFELKA

MADE IN EU

N.p.	specyfikacja	
52168		26



SZCZOTKA I SZUFELKA

MADE IN EU

N.p.	specyfikacja	
52173		26



SZCZOTKA STALOWA Z UCHWYTEM

N.p.	długość niasady	
52198	140 cm	1



MIOTŁA

MADE IN EU

N.p.	specyfikacja	
52119	29 cm	24



MIOTŁA ULICZNA Z UCHWYTEM

MADE IN EU

N.p.	specyfikacja	
52197	30 cm 120 cm drewniany	3



MIOTŁA ULICZNA

MADE IN EU

N.p.	specyfikacja	
52108	30 cm watek	25
61172	uchwyt 120 cm watek	1



MIOTŁA ULICZNA Z UCHWYTEM

N.p.	specyfikacja	
52135	145 cm 5x szyte	1



FESTA

MIOTŁA ULICZNA

N.p.	specyfikacja	
45323	37 cm	16





MIOTŁA ULICZNA



N.p.	specyfikacja	
52101	30 cm	10
52102	40 cm	10
52103	50 cm	10
52104	60 cm	10
52105	80 cm	10



MIOTŁA ULICZNA Z UCHWYTEM



N.p.	specyfikacja	długość niasady	
52190	30 cm	150 cm	3
52191	40 cm	150 cm	3
52192	50 cm	150 cm	3
52193	60 cm	150 cm	3
52194	80 cm	150 cm	3



MOQ 3

MIOTŁA



N.p.	specyfikacja	
52160	40 cm	10
52161	50 cm	10
52162	60 cm	10
52163	70 cm	10
52164	80 cm	10



MIOTŁA Z UCHWYTEM



N.p.	specyfikacja	długość niasady	
52185	40 cm	150 cm	3
52186	50 cm	150 cm	3
52187	60 cm	150 cm	3
52188	70 cm	150 cm	3
52189	80 cm	150 cm	3



MOQ 3

MIOTŁA



N.p.	specyfikacja	
52114	28 cm watek	1



MIOTŁA Z UCHWYTEM



N.p.	specyfikacja	długość niasady	
52116	28 cm	130 cm	3



MOQ 3

MIOTŁA



N.p.	specyfikacja	
52113	30 cm watek	26
52115	30 cm bez wateku	26



MIOTŁA Z UCHWYTEM



N.p.	specyfikacja	długość niasady	
52195	30 cm 150 cm drewniany	3	
52196	30 cm 130 cm ALU	3	



MOQ 3

GUMOWY ŚCIĄGACZ DO WODY

N.p.	specyfikacja	
15886	450 mm trzonek Ø 23 mm	48
15887	600 mm trzonek Ø 23 mm	48
15888	750 mm trzonek Ø 23 mm	32



MIOTŁA ULICZNA Z UCHWYTEM



N.p.	specyfikacja	
52109	25 cm 120 cm drewniany	12





FESTA

SZCZOTKA STALOWA

N.p.	specyfikacja		
22135	6 x 19 cm	bez uchwyt	8
22137	6 x 19 cm	z uchwytem 140 cm	MOQ 3



FESTA

SZCZOTKA NYLONOWA

N.p.	specyfikacja		
22136	6 x 19 cm	bez uchwyt	8
22138	6 x 19 cm	z uchwytem 140 cm	MOQ 3



MOP

N.p.	specyfikacja	
52110	30 cm	16



ZAPASOWY MOP

N.p.	specyfikacja	
52111	30 cm	1



FESTA

UCHWYT ALU

ALU

N.p.	specyfikacja	
45330	161 cm	24
45331	100 cm	24

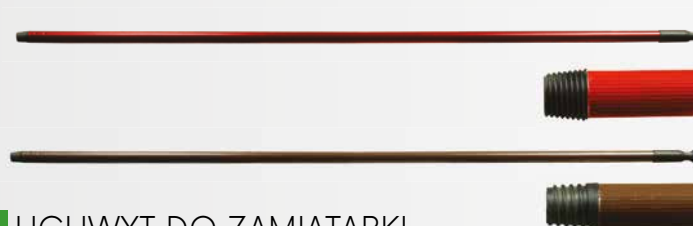
system click
ON - OFF

UCHWYT DO ZAMIATARKI

ALU MADE IN EU

N.p.	specyfikacja	
52126	130 cm, gruby watek	1

UCHWYT DO ZAMIATARKI

MADE IN EU

N.p.	specyfikacja	
61172	120 cm drewniany uchwyt z grubym watekiem	1
61192	150 cm drewniany uchwyt	pro 52195 1
61193	150 cm drewniany uchwyt	pro 52185 - 94 1
61194	140 cm drewniany uchwyt z grubym watekiem	1



UCHWYT DO ZAMIATARKI

MADE IN EU

N.p.	specyfikacja		N.p.	specyfikacja	
61171	1,2 m	1	61175	1,6 m	1
61173	1,4 m	1	61176	1,7 m	1
61174	1,5 m	1	61177	1,8 m	1

TRZONEK DO ŁOPATY



N.p.	specyfikacja	
61200	130 cm	10

TRZONEK DO ŁOPATY



N.p.	specyfikacja	
61201	130 cm, proste	10

TRZONEK DO SZPADLA "T,"



N.p.	specyfikacja	
61208	90 cm	10

TRZONEK DO ŁOPATY "T,"



N.p.	specyfikacja	
61202	130 cm, proste	10



TRZONEK DO CZERPAKA



N.p.	specyfikacja	
61215	160 cm	10



TRZONEK DO KILOFA



N.p.	specyfikacja	
61204	95 cm, wąski (pro 61120)	10
61205	95 cm	10



TRZONEK DO SZPADLA



N.p.	specyfikacja	
61207	100 cm	10



UCHWYT DO MOTYKI



N.p.	specyfikacja	
61219	120 cm	10



UCHWYT NA PLASTIKOWE GRABIE



N.p.	specyfikacja	
61195	120 cm	10

UCHWYT NA METALOWE GRABIE



N.p.	specyfikacja	
61183	150 cm	10
61184	160 cm	10
61189	170 cm	10
61190	180 cm	10

UCHWYT NA GRABIE



N.p.	specyfikacja	vhodné pro	
61250	160 cm	45051, 61048	20
61251	160 cm	45052	20
61252	160 cm	45320	20
61253	160 cm	45053	20
61254	160 cm	45054	20
61255	160 cm	45070	20
61256	160 cm	45055	20



PLASTIKOWA RĄCZKA

N.p.	specyfikacja	
61230		10

61079



120 cm

80 cm

N.p.	
61005	15
61006	15
61050	15
61051	15
61052	15
61079	1
61097	15
61098	15

61077



• zdjęcie ilustracyjne

STOJAK PROMOCYJNY NA ŁOPATE

N.p.	specyfikacja	
61077	stac z przedmiotami	1
61079	stac z paleta	1

UCHWYT NA NARZĘDZIA OGRODOWE

5x

N.p.	specyfikacja	
51184		12



• obracające się gumowe rolki

UCHWYT NA NARZĘDZIA OGRODOWE

N.p.	specyfikacja	
51185	45 cm	5

• zdjęcie ilustracyjne | a

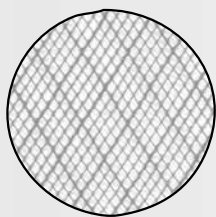

SIATKA PRZECIWKO
OWADOM

N.p.	specyfikacja		
40100	1 x 25 m - PE biały		1
40120	1,2 x 25 m - PE biały		1

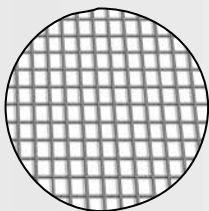
SIATKA PRZECIWKO
OWADOM

Zn

N.p.	specyfikacja		
42101	1 x 30 m - ALUMINIUM		2
42103	1 x 30 m - galwanizowany drut		2

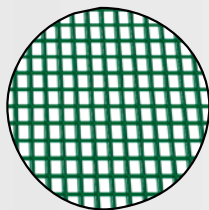
SIATKA PRZECIWKO
OWADOM

N.p.	specyfikacja		
42102	1 x 30 m - zielony drut stalowy		2

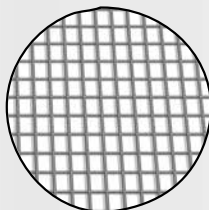
SIATKA PRZECIWKO
OWADOM - FIBERGLASS

N.p.	specyfikacja			
41083	0,8 x 30 m	biały	6	
41103	1 x 30 m	biały	6	
41123	1,2 x 30 m	biały	6	
41153	1,5 x 30 m	biały	6	

N.p.	specyfikacja			
41082	0,8 x 30 m	biały-szara	6	
41102	1 x 30 m	biały-szara	6	
41122	1,2 x 30 m	biały-szara	6	
41152	1,5 x 30 m	biały-szara	6	

N.p.	specyfikacja			
41050	0,5 x 30 m	szara	6	
41080	0,8 x 30 m	szara	6	
41100	1 x 30 m	szara	6	
41120	1,2 x 30 m	szara	6	
41150	1,5 x 30 m	szara	6	

N.p.	specyfikacja			
41081	0,8 x 30 m	czarna	6	
41101	1 x 30 m	czarna	6	
41121	1,2 x 30 m	czarna	6	
41151	1,5 x 30 m	czarna	6	





SIATKA OKIENNA
BIAŁY



Ć.p.	specyfikacja		
40050	150 x 130 cm	5,6 m	10
40052	150 x 180 cm	6,6 m	10
40054	150 x 90 cm	4,8 m	10
40056	220 x 75 cm 2 szt.	5,8 m	10



SIATKA OKIENNA
SZARA



Ć.p.	specyfikacja		
40051	150 x 130 cm	5,6 m	10
40053	150 x 180 cm	6,6 m	10
40055	150 x 90 cm	4,8 m	10



SIATKA OKIENNA
CZARNA



N.p.	specyfikacja		
40057	150 x 130 cm	5,6 m	10
40058	150 x 180 cm	6,6 m	10
40059	150 x 90 cm	4,8 m	10



TASMA
MONTAZOWA
Z RZEPEM

N.p.	specyfikacja	
40060	9 mm 7 m	1

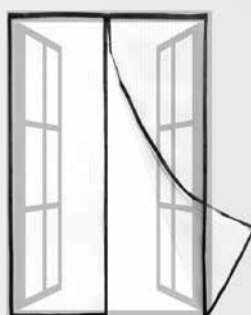

KURTYNA DRZWIOWA
PRZED INSEKTAMI
MAGNETYCZNA - ANTRACYT



N.p. No.	Specyfikacja Specification	
40077	100 x 220 cm	1



ZASŁONA NA DRZWI
PRZECIWKO OWADOM

zmienny rozmiar 60 - 120 cm

N.p.	specyfikacja		
40075	4 x 35 x 220 cm biały	20	
40076	4 x 35 x 220 cm czarna	20	

SIATKA HEX



Zn

N.p.	specyfikacja	
42150	13 0,7 x 1000 mm - 50 m	1
42151	16 0,7 x 1000 mm - 50 m	1
42152	20 0,7 x 1000 mm - 50 m	1
42153	25 0,8 x 1000 mm - 50 m	1

SIATKA HEX



Zn

N.p.	specyfikacja	
42155	13 0,7 x 1000 mm - 50 m	1
42156	16 0,7 x 1000 mm - 50 m	1
42157	20 0,7 x 1000 mm - 50 m	1
42158	25 0,8 x 1000 mm - 50 m	1

SIATKA HEX
POPLASTOWE



Zn

N.p.	specyfikacja	
42160	13 1 x 1000 mm - 25 m	1
42161	16 1 x 1000 mm - 25 m	1
42162	20 1 x 1000 mm - 25 m	1
42163	25 1 x 1000 mm - 25 m	1

SIATKA OZDOBNA



N.p.	rozmiar oczu	Ø drutu	wysokosc	length	
42175	15 x 9 mm	2 mm	40 cm	25 m	1
42176	15 x 9 mm	2 mm	65 cm	25 m	1
42177	15 x 9 mm	2 mm	90 cm	25 m	1
42178	15 x 9 mm	2 mm	120 cm	25 m	1
42179	15 x 9 mm	2 mm	25 cm	25 m	1

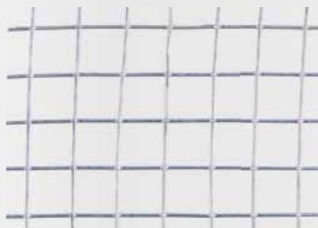

SIATKA PROSTOKĄT

140
g/m² UV
STABLE

N.p.	specyfikacja	N.p.	specyfikacja
42185	6 0,65 x 1000 mm - 25 m	42174	25 1,4 x 1000 mm - 25 m
42170	10 0,8 x 100 mm - 25 m	42186	13 1,05 x 1000 mm - 25 m
42171	13 0,8 x 1000 mm - 25 m	42187	25 2,0 x 1000 mm - 25 m
42172	16 1,2 x 1000 mm - 25 m	42188	50 2,0 x 1000 mm - 25 m
42173	19 1,4 x 1000 mm - 25 m		

SIATKA DRUCIANA



N.p.	specyfikacja	
42180	13 1,2 x 1000 mm - 25 m	1
42181	16 1,2 x 1000 mm - 25 m	1
42182	25 2,3 x 1000 mm - 25 m	1

SIATKA PRZECIWIW PTAKOM

MADE IN
EU

N.p.	specyfikacja	
45570	2 x 5 m 18 x 18 mm	45
45571	2 x 10 m 18 x 18 mm	28
45572	4 x 5 m 18 x 18 mm	24
45573	4 x 10 m 18 x 18 mm	15

OGRODZENIA BEZPIECZEŃSTWA

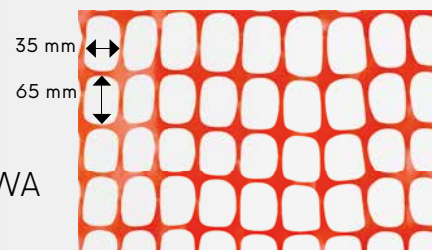
140
g/m² UV
STABLE

N.p.	specyfikacja	
42190	1,2 x 50 m HDPE 140g/m ²	1

SIATKA RABICO



Zn

N.p.	specyfikacja	
42312	1 m 50 bm, 16 x 16 mm	1

SAMOZACISKAJĄCA
OSŁONA
ZABEZPIECZAJĄCA

samoblokujący

3x
MADE IN
EU

N.p.	specyfikacja	
45580	Ø 11 x 80 cm	1



DRUT DO WIĄZANIA

Zn

N.p.	Ø drutu	długość drutu	
42203	0,6 mm	30 m	50



DRUT DO WIĄZANIA

N.p.	Ø drutu	długość drutu	powrch	
42201	0,6 mm	30 m	PVC	50
42202	0,9 mm	30 m	PVC	50



DRUT KOLCZYSTY

Zn

N.p.	Ø drutu	długość drutu	
42260	1,7 mm	50 m	1
42261	1,7 mm	100 m	1



WYCIĄGARKA

N.p.	specyfikacja	
50035	2 t	6
50036	4 t	4



NACIĄGACZ DRUTU OGRÓDZENIA - MAŁY

Zn

N.p.	specyfikacja	
50030	ocynkowane, Zn	50
50032	PVC	50

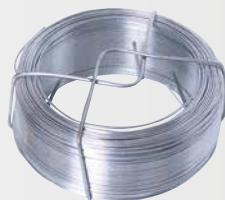

DRUT DO WIĄZANIA

Zn

N.p.	Ø drutu	długość drutu	
42207	0,8 mm	50 m	40
42208	0,8 mm	100 m	20
42209	0,9 mm	100 m	20
42240	1,0 mm	50 m	40
42210	1,0 mm	100 m	20
42211	1,2 mm	50 m	40
42212	1,2 mm	100 m	20
42213	1,4 mm	30 m	40
42214	1,4 mm	50 m	20
42217	1,8 mm	30 m	40
42218	1,8 mm	50 m	20



DRUT DO WIĄZANIA - ZIELONY PCV

N.p.	Ø drutu	długość drutu	
42244	1,4 mm	50 m	20
42248	1,8 mm	50 m	20
42249	2,0 mm	50 m	20



ZACISK DRUTU OGRÓDZENIA

N.p.	specyfikacja	MOQ	
50040	zielony	50	50
50041	czarny	50	50



NACIĄGACZ DRUTU OGRÓDZENIA - DUŻY

Zn

N.p.	specyfikacja	
50031	ocynkowane Zn	50
50033	PVC	50

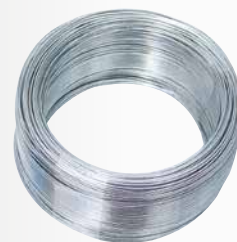

DRUT

Zn

N.p.	Ø drutu	długość drutu	
42219	2,0 mm	26 m	20
42220	2,0 mm	52 m	20
42221	2,0 mm	78 m	20
42228	3,15 mm	26 m	10
42229	3,15 mm	52 m	10
42230	3,15 mm	78 m	10



DRUT - ZIELONY PCV

N.p.	Ø drutu	długość drutu	
42251	2,6 mm	26 m	20
42252	2,6 mm	52 m	20
42253	2,6 mm	78 m	20
42255	3,4 mm	26 m	10
42256	3,4 mm	52 m	10
42257	3,4 mm	78 m	10



ZACISK DRUTU OGRÓDZENIA

N.p.	specyfikacja	MOQ	
50042		10	10



NACIĄGACZ DRUTU OGRÓDZENIA - LEKKI

Zn

N.p.	specyfikacja	
50037	ocynkowane	50
50038	Powlekane PCV	50

WSPORNIK SŁUPKA

Zn

N.p.	specyfikacja	tl.		
55436	70 x 75 mm	110 mm	4 mm	10
55437	80 x 90 mm	130 mm	4 mm	10



Ø 18 x 200 mm

WSPORNIK SŁUPKA

Zn

N.p.	specyfikacja	tl.		
55429	70 x 60 mm	100 mm	4 mm	10
55433	81 x 60 mm	100 mm	4 mm	10
55430	91 x 60 mm	100 mm	4 mm	10
55431	101 x 60 mm	100 mm	4 mm	10
55432	121 x 60 mm	100 mm	4 mm	10



Ø 18 x 200 mm

STOPA KOTWY KOLUMNY NASTAWNA

Zn

N.p. / No.	Specyfikacja / Specification	tl.		
55465	80 - 160 x 70 mm	100 mm	4 mm	1

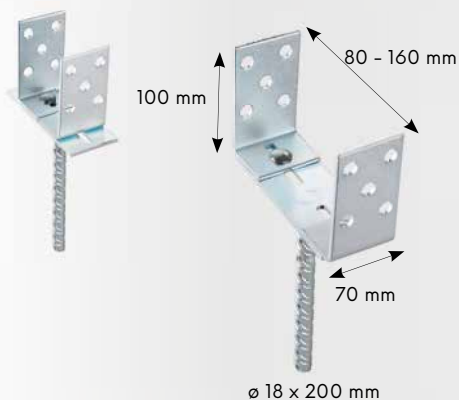

Ø 18 x 200 mm

WSPORNIK SŁUPKA

Zn

N.p.	Ø kotwica	długość kotwicy	długość kotwicy	
55420	71 x 71 mm	150 mm	2 mm	1
55425	81 x 81 mm	150 mm	2 mm	1
55421	91 x 91 mm	150 mm	2 mm	1
55422	101 x 101 mm	150 mm	2 mm	1
55423	121 x 121 mm	150 mm	2 mm	1
55424	151 x 151 mm	150 mm	2 mm	1



STOPA KOLUMNY Z REGULOWANĄ ŚRUBĄ

Zn

N.p.	Ø kotwica	wysokość kotwicy	wątek	
55460	80 x 80 mm	150 mm	M16	10
55461	100 x 100 mm	150 mm	M16	10
55462	150 x 150 mm	150 mm	M24	10



WIERTŁO GLEBOWE

N.p.	Ø	A	B	
61299	110 mm	270 mm	1200 mm	1
61300	140 mm	270 mm	1200 mm	1
61301	170 mm	270 mm	1200 mm	1
61302	200 mm	270 mm	1200 mm	1



WSPORNIK SŁUPKA

Zn

N.p.	Ø kotwica	długość kotwicy	długość kotwicy	
55400	71 x 71 mm	750 mm	2 mm	1
55401	91 x 91 mm	750 mm	2 mm	1
55406	81 x 81 mm	750 mm	2 mm	1
55402	91 x 91 mm	900 mm	2 mm	1
55403	101 x 101 mm	900 mm	2 mm	1
55404	121 x 121 mm	900 mm	2 mm	1
55405	151 x 151 mm	900 mm	2 mm	1



KOTWICA ZIEMNA OGRODOWA "U"

Zn

N.p.	Ø kotwica	długość kotwicy	długość kotwicy	
55455	71 x 60 mm	100 mm	4 mm	1
55452	81 x 60 mm	100 mm	4 mm	1
55456	90 x 60 mm	100 mm	4 mm	1
55453	101 x 60 mm	100 mm	4 mm	1
55457	110 x 60 mm	100 mm	4 mm	1
55454	121 x 60 mm	100 mm	4 mm	1

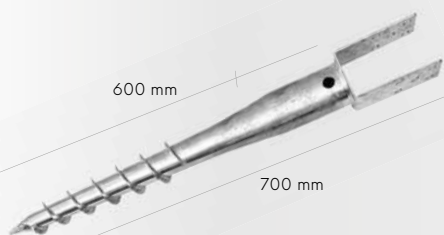

KOTWICA ZIEMNA OGRODOWA

redukcja

Ø 24 mm
 Ø 35 mm
 Ø 40 mm
 Ø 48 mm
 Ø 55 mm

Zn 6x

N.p.	Ø kotwica	długość kotwicy	specyfikacja	
55450	60 mm	550 mm	1 szt. + 5x redukcja	8

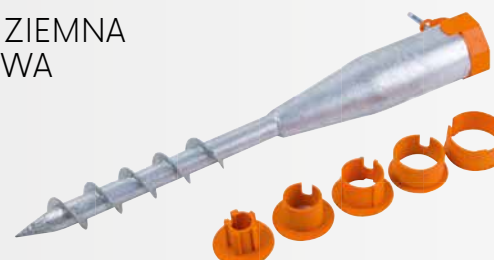

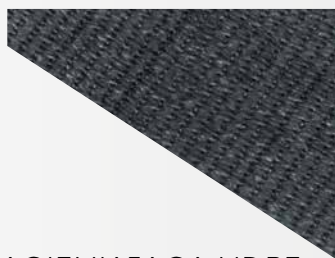

**MATA ZACIENIAJĄCA HDPE
150 G/ M² ANTRACYT**

· zacinienie 85%



N.p.	specyfikacja	
45496	1 x 10 m	1
45497	1,5 x 10 m	1
45498	1,8 x 10 m	1
45499	2 x 10 m	1

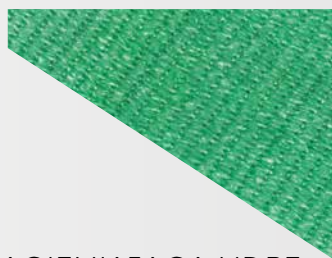

**MATA ZACIENIAJĄCA HDPE
150 G/ M²**

· zacinienie 85%



N.p.	specyfikacja	
45460	1 x 10 m	1
45461	1,5 x 10 m	1
45463	1,8 x 10 m	1
45462	2 x 10 m	1



**MATA ZACIENIAJĄCA HDPE
220 G/ M²**

· zacinienie 95%

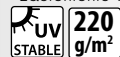

N.p.	specyfikacja	
45465	1 x 10 m	1
45466	1,5 x 10 m	1
45467	2 x 10 m	1



**MATA ZACIENIAJĄCA
HDPE 80 G/ M²**



N.p.	specyfikacja	
45450	1 x 10 m	1
45451	1,5 x 10 m	1
45453	1,8 x 10 m	1
45452	2 x 10 m	1

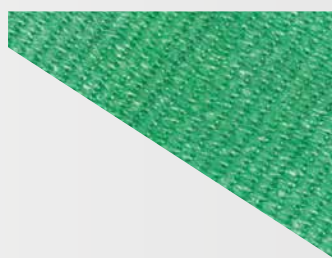

**MATA ZACIENIAJĄCA HDPE
150 G/ M²**

· zacinienie 85%



N.p.	specyfikacja	
45480	1,5 x 50 m	1



**MATA ZACIENIAJĄCA
HDPE 220 G/ M²**

· zacinienie 95%

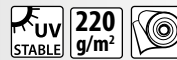

N.p.	specyfikacja	
45485	1,5 x 50 m	1



PASKI MOCUJĄCE

· EN 50146
· nylon



N.p.	specyfikacja	
23875	120 mm 4,8 mm	1



**ZACISK TKANINY
CIENIUJĄCEJ**



N.p.	specyfikacja	
45470		1





ZESTAW NARZĘDZI DO GRILOWANIA

INOX 18x

N.p. specyfikacja

43077



6

6



ZESTAW NARZĘDZI DO GRILOWANIA

INOX 3x

N.p. specyfikacja

43071 380 mm



16

16



GRILL KLESZCZE

INOX

N.p. specyfikacja

43072 360 mm



25

25



TACA DO GRILOWANIA ALU

4x

N.p. specyfikacja

43050 300 x 200 mm

50

50

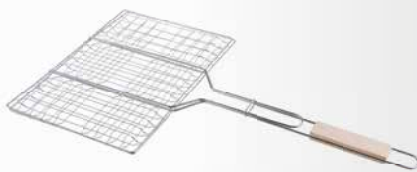

KRATKA DO OPIEKANIA

N.p. specyfikacja

43084 330 x 290 mm

50

50

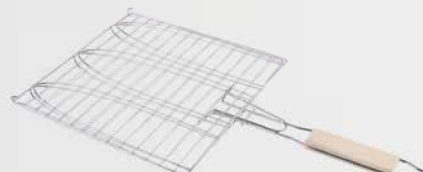

OPIEKACZ DO RYB

N.p. specyfikacja

43082 280 x 276 mm

50

50

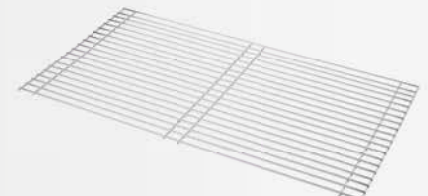

RUSZTY DO GRILA

N.p. specyfikacja

43058 58 x 30 mm

20

43060 60 x 40 mm

20

43068 68 x 40 mm

16



OPIEKACZ DO RYB

N.p. specyfikacja

43083 360 x 130 mm

12

12



PATYCZKI DO SZASZŁYKÓW

4x

N.p. specyfikacja

43086 Ø 3 x 380 mm

80

80



WIDELEC DO GRILOWANIA

* widelec do grillowania z higienicznym atestem

N.p. specyfikacja

43097 100 cm

100

100



285 - 900 mm

WIDELEC GRILLOWY - TELESKOPOWY

INOX



N.p. specyfikacja
43094

1



DMUCHAWA



N.p. specyfikacja
43087

1



SZCZOTKA DO CZYSZCZENIA 2 W 1

N.p. specyfikacja
43098 30 cm

10



SZCZOTKA DO CZYSZCZENIA 3 W 1

N.p. specyfikacja
43099

40



SILNIK DO GRILA 230V

CE



N.p. specyfikacja
43090

24



SILNICZEK DO GRILA



N.p. specyfikacja
43089

48



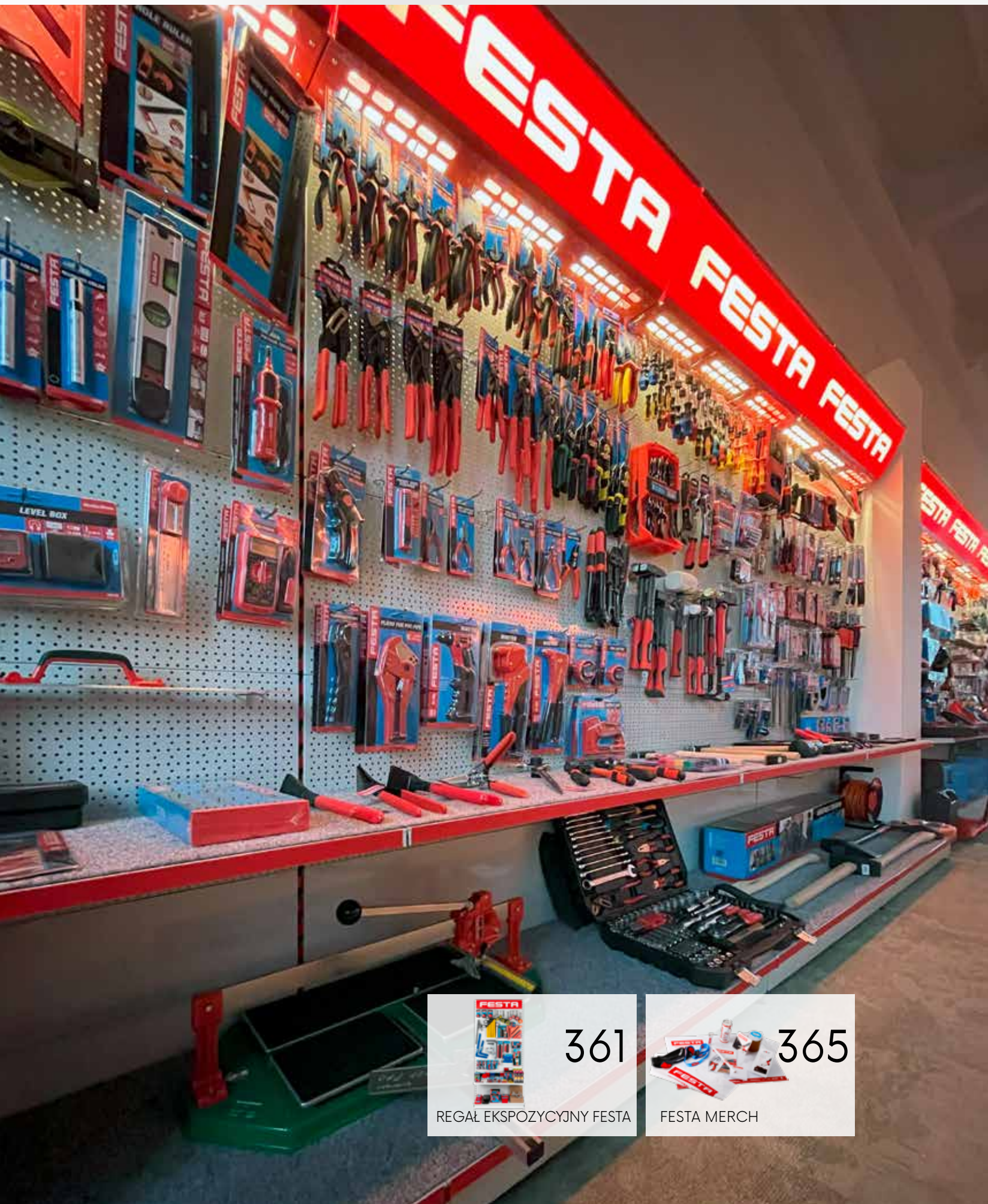

361

REGAŁ EKSPOZYCYJNY FESTA



365

FESTA MERCH



 REGAŁ EKSPOZYCYJNY FESTA WYPEŁNIONY PRZEDMIOTAMI

FESTA

LIGHTBOX NA STOISKO FESTA 81011

N.p.	specyfikacja	
81195	FESTA POWER TOOLS	1
81196	FESTA	1
81197	FESTA INDUSTRY	1



REGAŁ EKSPOZYJNY FESTA



N.p.	specyfikacja	
81011	stojak FESTA CZ 200 x 100 cm	1
81011A	stojak 81011 + naklejka AQUATIC	1
81011F	stojak 81011 + naklejka FESTA CZ	1
81011G	stojak 81011 + naklejka FESTA GB	1
81011H	stojak 81011 + naklejka FESTA SK	1
81011R	stojak 81011 + naklejka ROSA	1
81012	półka CZ głębokość 40 cm	8
81013	hak 10 cm	10
81014	hak 16 cm	10
81015	hak 20 cm	10
81035	hak 20 cm	10
81016	hak 30 cm	10
81036	hak 30 cm	10
81022	kosz z drutu - duży 50 cm	1
81023	kosz z drutu - mały 40 cm	1
81024	przegroda - duży 50 cm	1
81025	przegroda - mały 40 cm	1

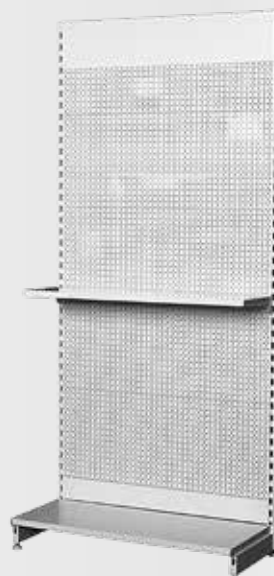

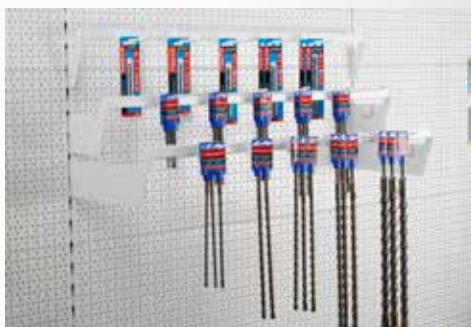

KONSOLA

kompatybilny ze stojakiem FESTA

N.p.	specyfikacja	
81150	1000 x 50 x 135 mm	1
81151	1000 x 150 x 135 mm	1
81152	1000 x 350 x 135 mm	1

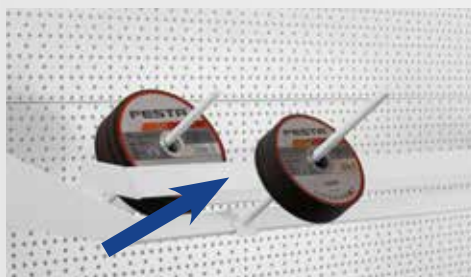

UCHWYT CENOWY

kompatybilny ze stojakiem FESTA

N.p.	specyfikacja	
81155	1000 x 80 x 100 mm	1



HAK DO TARCZ

kompatybilny ze stojakiem FESTA

N.p.	specyfikacja	
81186	150 mm	1
81185	250 mm	1



RAMA DO TARCZ

kompatybilny ze stojakiem FESTA

N.p.	specyfikacja	
81170	1000 x 450 x 85 mm	1



UCHWYT NA PIŁY

kompatybilny ze stojakiem FESTA

N.p.	specyfikacja	
81190		1



HAK NA AKU NARZĘDZIA

kompatybilny ze stojakiem FESTA

N.p.	specyfikacja	
81189		1



PÓŁKA NA DYSKI

kompatybilny ze stojakiem FESTA

N.p.	specyfikacja	
81191	220 x 220 x 200 mm	1

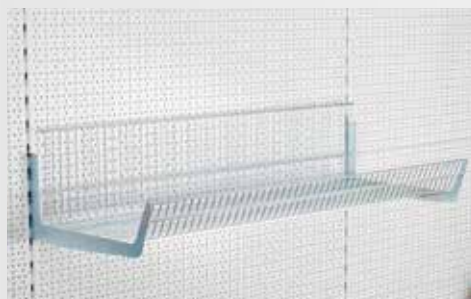

KOSZ Z DRUTU

kompatybilny ze stojakiem FESTA

N.p.	specyfikacja	
81160	1000 x 470 x 180 mm	1



PRZEGRODA

kompatybilny ze stojakiem FESTA

N.p.	specyfikacja	
81165	470 x 180 mm	1



UCHWYT NA MŁOTKI

Zn

kompatybilny ze stojakiem FESTA

N.p.	specyfikacja	
81188	max 2 kg	1

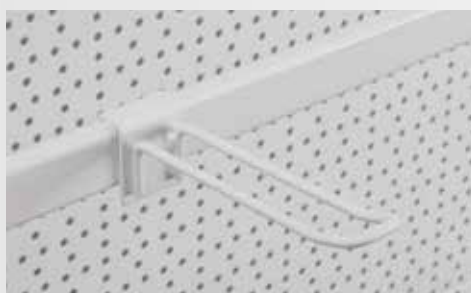

PODWÓJNY HAK

kompatybilny ze stojakiem FESTA

N.p.	specyfikacja	
81175	120 mm	1
81178	180 mm	1



HAK

kompatybilny ze stojakiem FESTA

N.p.	specyfikacja	
81180	120 mm	1



N.p.	specyfikacja	
81200	Szyna nośna 40/2400 mm zakotwiczony	1
81201	Szyna nośna 80/1108 mm	1
81202	Szyna nośna 80/1208 mm	1
81203	Szyna nośna 80/1408 mm	1
81204	Szyna nośna 80/1608 mm	1
81205	Szyna nośna 80/1808 mm	1
81206	Szyna nośna 80/2000 mm	1
81207	Szyna nośna 80/2108 mm	1
81208	Szyna nośna 80/2208 mm	1
81209	Szyna nośna 80/2308 mm	1
81210	Szyna nośna 80/2408 mm	1
81211	Szyna nośna 80/2600 mm	1
81212	Szyna nośna 60/1000 mm	1
81213	Szyna nośna 60/1208 mm	1
81214	Szyna nośna 60/1408 mm	1
81215	Szyna nośna 60/1608 mm	1
81216	Szyna nośna 60/1808 mm	1
81217	Szyna nośna 60/2108 mm	1
81218	Szyna nośna 60/2208 mm	1
81225	Szyna nośna 30/2108 mm z przodu	1
81486	Szyna nośna 60/2000 mm	1
81219	Końcówka szyny nośnej 80x30/100mm	1
81220	Końcówka szyny nośnej 80x30/400 mm	1
81221	Końcówka szyny nośnej 80x30/600 mm	1
81222	Końcówka szyny nośnej 60x30/400 mm	1
81223	Szyna nośna narożna 90° 2100mm	1
81224	Szyna nośna narożna 90° 2200mm	1
81226	Podpórka 80	1
81227	Podpórka 60	1
81228	Łącznik gondoli z regałem 80	1
81229	Listwa mocująca	1
81230	Hak mocujący	1
81231	Zamocowanie lekkie	1
81232	Zamocowanie górne	1
81233	Wykładzina 400	1
81234	Wykładzina 500	1
81235	Wykładzina 600	1
81236	Wykładzina 700	1
81237	Wykładzina 800	1
81238	Konsola niska 200	1
81239	Konsola niska 300	1
81240	Konsola niska 400	1
81241	Konsola niska 500	1
81242	Konzola wysoka 400	1
81243	Konzola wysoka 500	1
81244	Konzola wysoka 600	1
81245	Konzola wysoka 700	1
81246	Konsola niska 300 podwójna	1
81247	Konsola niska 400 podwójna	1
81248	Konsola niska 300 podwójna	1
81251	Konsola RR 80	1
81249	Konsola wysoka podwójna 500	1
81250	Belka wysokiej witriny 400/2000	1
81252	Podziałka półki korytkowej	1
81253	Podziałka niska 300	1
81254	Podziałka niska 400	1
81255	Podziałka niska 500	1
81256	Podziałka niska 300 szkło	1
81257	Podziałka niska 400 szkło	1
81258	Podziałka niska 500 szkło	1
81259	Podziałka wysoka 300 szkło	1
81262	Podziałka wysoka 300 plexi	1
81263	Podziałka wysoka 400 plexi	1
81264	Podziałka wysoka 500 plexi	1
81260	Podziałka wysoka 400 szkło	1
81261	Podziałka wysoka 500 szkło	1
81265	Strona prezentacji 400/2000	1
81266	Pokrywa boczna konsoli RR 80	1
81267	Strona szafka 500mm	1
81268	Strona wyświetlacza ze szkła 500	1
81269	Hórne wsparcie 500 vit.	1
81271	Ściana boczna półka niska 300 plast	1
81272	Ściana boczna półka niska 400 plast	1
81273	Ściana boczna półka niska 500 plast	1
81274	Ściana boczna wysoka szkło 300/250	1
81275	Bezpiecznik ściana boczna	1
81276	Ściana boczna wysoka szkło 500/250	1
81277	Ściana boczna półka wysoka 400	1
81278	Ściana boczna półka wysoka 500	1
81270	Belka zadaszienia RR 80	1
81279	Belka zadaszienia	1
81280	Pokrywa boczna konsoli Lewo	1
81281	Pokrywa boczna konsoli Prawo	1
81282	Hak do wieszania	1
81284	Wieszak odzieżowy podwójnie 400/10	1
81285	Wieszak odzieżowy podwójnie 300/8	1
81286	Wieszak odzieżowy pojedynczy 350	1
81287	Wieszak odzieżowy pojedynczy 500	1
81288	Wieszak odzieżowy pojedynczy 250	1
81289	Hak do wieszania podwójna 100	1
81290	Hak do wieszania podwójna 200	1
81291	Hak do wieszania podwójna 300	1
81292	Hak do wieszania 130 V	1

N.p.	specyfikacja	
81293	Hak do wieszania 100	1
81294	Hak do wieszania 200	1
81295	Hak do wieszania 300	1
81296	Hak z poziomym pasku 200	1
81297	Hak z poziomym pasku 300	1
81298	Zamek witriny	1
81299	Podziałka drucianej 360mm wysoka	1
81300	Podziałka drucianej 460 mm wysoka	1
81301	Podziałka drucianej 560 mm wysoka	1
81302	Podziałka drucianej 560 mm niska	1
81303	Konsola 300 podwójna L	1
81304	Konsola 300 podwójna P	1
81305	Konsola 400 podwójna L	1
81306	Konsola 400 podwójna P	1
81307	Konsola 500 podwójna L	1
81308	Konsola 500 podwójna P	1
81309	Półka półkole 300	1
81310	Półka półkole 400	1
81311	Półka półkole 500	1
81312	Cokołu półkole 500	1
81313	Cokołu półkole 500	1
81314	Uchwyt cenowy półkole 300	1
81315	Uchwyt cenowy półkole 400	1
81316	Uchwyt cenowy półkole 500	1
81317	Półka półkole 600	1
81318	Sokół półkole 600	1
81319	Cokołu narożny półkole 600	1
81320	Metka P 7,5x5 cm	1
81321	Metka P 2,6x3,2 cm	1
81322	Metka P 5,0x4,0 cm	1
81323	Półka perforowana 500/1000	1
81324	Spójnik szyna nośna 80, modul 1	1
81325	Panel tylny 10x100cm	1
81326	Panel tylny 20x100cm	1
81327	Panel tylny 40x100cm	1
81328	Panel tylny perf. 20x100 cm EUR	1
81329	Panel tylny perf. 40x100 cm EUR	1
81330	Obudowa gondoli 8x100cm	1
81331	Obudowa gondoli 6x100cm	1
81332	Belka do zasłon 100cm	1
81333	Półka szkło 985/300 vitrina	1
81334	Półka szkło 985/400 vitrina	1
81335	Półka drewniana 47/98,5	1
81336	Półka druciana 1000/500	1
81337	Półka głęboki 1000x500	1
81338	Półka 200/1000	1
81339	Półka 300/1000	1
81340	Półka 400/1000	1
81341	Półka 500/1000	1
81342	Półka 400/1000 RAL7015	1
81343	Półka 500/1000 RAL7015	1
81347	Rama wysokie witriny 1000/400	1
81348	Szko rama wysokie witriny 1000/400	1
81349	Szufflada	1
81350	Pułap metalowej półce 500/100	1
81352	Podpórka frontu wysoka 1000 mm, szkło	1
81353	Podpórka frontu wysoka, plexi	1
81354	Podpórka frontu niska 1000 mm, plast	1
81355	Listwa cenowa, 1000mm	1
81356	Grzebień Szufflada	1
81351	Grzebień do wysoka podziałka, 1000	1
81357	Grzebień, 1000 mm	1
81403	Grzebień do wysoka podziałka, 1250 mm	1
81420	Grzebień do wysoka podziałka, 625 mm	1
81358	Podwójnie rowkować drzwiczki witriny	1
81359	Uchwyt cenowy, 1000mm	1
81360	Drzwiczki witriny 1000/2000	1
81361	Front zadaszienia, 1000mm	1
81362	Deska zadaszienia, 1000mm	1
81363	Drzwiczki suplier	1
81364	Drzwiczki przesuwane do witriny	1
81365	Lustro witriny	1
81366	Rama do wieszania, modul 1	1
81367	Drag do wieszania	1
81370	kosz drucziany skośny	1
81371	Lada sklepowa pełna 1000mm	1
81372	Cokoł lady sklepowej SU 5 1000mm	1
81373	Lada sklepowa przeszklona 1000mm	1
81374	Lada sklepowa z białym nierdz. 1000mm	1
81375	Lada sklepowa pełna 600mm	1
81376	Półka do lady sklepowej 600mm	1
81377	Lada sklepowa przeszklona 600mm	1
81378	Półka do lady sklepowej 1000mm	1
81379	Półka do lady sklepowej długa	1
81380	segment wysoki 90°	1
81381	Podwójnie rowkować do lady 1000mm	1
81382	Drzwiczki przesuwane, pułt 1000mm, par	1
81383	Szufflada	1
81384	Półka drucziana RDE 1000/360mm	1
81385	Półka drucziana RDE 1000/460mm	1
81386	Półka drucziana RDE 1000/560mm	1
81387	Listwa cenowa RDE 1000 mm	1
81388	Panel tylny 100/1250mm	1

N.p.	specyfikacja	
81389	Panel tylny 200/1250mm	1
81390	Panel tylny 400/1250mm	1
81391	Panel tylny 200/1250mm perforowany	1
81393	Obudowa gondoli 80/1250mm	1
81392	Panel tylny 400/1250mm perforowany	1
81394	Obudowa gondoli 60/1250mm	1
81395	Belka do zasłon 1250mm	1
81396	Półka 200/1250mm	1
81439	Nosnik závěsů 1000 mm	1
81344	Półka 300/1000 zesilená	1
81345	Półka 400/1000 zesilená	1
81346	Półka 500/1000 zesilená	1
81397	Półka 300/1250mm	1
81400	Półka 300/1250mm, zesilená	1
81401	Półka 400/1250mm, zesilená	1
81402	Półka 500/1250mm, zesilená	1
81398	Półka 400/1250mm	1
81399	Półka 500/1250mm	1
81404	Podpórka frontu niska 1250mm, biały plastik	1
81405	Listwa cenowa, 1250mm	1
81406	Grzebień 1250mm	1
81407	Uchwyt cenowy, 1250mm	1
81408	Front zadaszienia, 1250mm	1
81409	Deska zadaszienia, 600x1250mm	1
81410	Panel tylny 100/625	1
81411	Panel tylny 200/625	1
81412	Panel tylny 400/625	1
81413	Panel tylny 400/625 perforowany	1
81414	Obudowa gondoli 80/650	1
81415	Obudowa gondoli 60/650	1
81416	Belka do zasłon, modul 3	1
81432	Belka do zasłon, 1330mm	1
81417	Półka 300/625	1
81418	Półka 400/625	1
81419	Półka 500/625	1
81421	Podpórka frontu niska 625, biały plastik	1
81422	Listwa cenowa 625mm	1
81423	Grzebień 625mm	1
81424	Uchwyt cenowy, 625mm	1
81425	Panel tylny 100/1330	1
81457	Podpórka frontu niska 200 plast	1
81426	Panel tylny 200/1330	1
81427	Panel tylny 400/1330	1
81428	Panel tylny 200/1330 perforowany S	1
81429	Panel tylny 400/1330 perforowany S	1
81430	Obudowa gondoli 80/1330	1
81431	Obudowa gondoli 60/1330	1
81433	Półka 300/1330	1
81434	Półka 400/1330	1
81435	Półka 500/1330	1
81436	Listwa cenowa, 1330 mm	1
81437	Grzebień 1330 mm	1
81438	Uchwyt cenowy 1330 mm	1
81440	Półka drucziana - kosz	1
81441	Panel tylny 100 kąt	1
81442	Panel tylny 400 kąt	1
81443	Front cokołu kąt 500/1000mm	1
81444	Front cokołu kąt 600 mm	1
81445	Panel tylny kąt 400mm perforowany	1
81447	Półka 300 kąt	1
81448	Półka 400 kąt	1
81449	Półka 500 kąt	1
81450	Półka 600 kąt	1
81451	Uchwyt cenowy 300 kąt	1
81452	Uchwyt cenowy 400 kąt	1
81453	Uchwyt cenowy 500 kąt	1
81454	Listwa cenowa 300 kąt	1
81455	Listwa cenowa 400 kąt	1
81456	Listwa cenowa 500 kąt	1
81458	Półka drucziana kosz U 1000/400	1
81459	Półka drucziana kosz U 1000/500	1
81460	Front cokołu narożny 90°	1
81461	Panel tylny narożny 100, Szyna nośna 60	1
81462	Panel tylny narożny 200, Szyna nośna 60	1
81463	Panel tylny narożny 400, Szyna nośna 80	1
81466	Panel tylny narożny 100, Szyna nośna 80	1
81467	Panel tylny narożny 400, Szyna nośna 60	1
81468	Półka narożna 90° 400mm	1
81469	Półka narożna 90° 500mm	1
81470	Uchwyt cenowy narożny 90° 400mm	1
81471	Uchwyt cenowy narożny 90° 500mm	1
81472	Listwa cenowa narożna 90° 400mm	1
81473	Listwa cenowa narożna 90° 500mm	1



WSPORNIK BIAŁY

MOQ
2

N.p.	specyfikacja	
81100	100 x 75 mm	24
81101	125 x 100 mm	24
81102	150 x 125 mm	24
81103	200 x 150 mm	24
81104	250 x 200 mm	24
81105	300 x 250 mm	24
81106	350 x 300 mm	24



SZYNA REGAŁOWA PROSTA

N.p.	specyfikacja	
81053	50 cm	10
81054	80 cm	10
81057	200 cm	10



HAK REGAŁOWY PROSTY

N.p.	specyfikacja	
81070	10 cm	10
81071	15 cm	10
81077	50 cm	10



PAPIEROWY STOJAK LEVELING SYSTEMS



N.p.	specyfikacja	
37179	60 x 40 x 175 cm - ENG	1



PAPIEROWY STOJAK FESTA



N.p.	specyfikacja	
81602	60 x 40 x 175 cm - ENG	1

PAPIEROWY STOJAK FESTA POWER TOOLS



N.p.	specyfikacja	
81603	60 x 40 x 175 cm	1



FESTA

BŁOK REKLAMOWY FESTA

N.p. specyfikacja
M90400



1

FESTA

CZERWONA KOSZULKA REKLAMOWA

N.p.	specyfikacja	
M90203	M	1
M90204	L	1
M90205	XL	1
M90206	XXL	1
M90207	XXXL	1



FESTA

DŁUGOPIS REKLAMOWY FESTA

N.p. specyfikacja
M90403



1



FESTA

REKLAMOWE SKARPETKI FESTA

N.p.	specyfikacja	
M90220	39-41	1
M90221	42-44	1
M90222	45-47	1



FESTA

REKLAMOWY KABEL USB FESTA

N.p. specyfikacja
M90519



1



FESTA

CZAPKA REKLAMOWA FESTA

N.p.	specyfikacja	
M90210		1



FESTA

MIERNIK REKLAMY FESTA

N.p. specyfikacja
11410 2 m x 16 mm

MOQ
12



1

FESTA

REKLAMOWY NÓŻ SKŁADANY FESTA

N.p. specyfikacja
16209



1



kod produktu	str.	kod produktu	str.	kod produktu	str.	kod produktu	str.	kod produktu	str.	kod produktu	str.
10002	96	11355	98	13249	121	13414	101	13509	99	14420	104
10003	96	11356	98	13250	121	13415	101	13510	99	14421	104
10005	96	11358	98	13251	121	13416	101	13511	99	14425	105
10008	96	11360	98	13252	121	13417	101	13512	99	14430	105
10025	96	11410	100	13253	121	13418	101	13513	99	14435	105
10033	96	11410	365	13254	121	13419	101	13514	99	14440	105
10035	96	11416	99	13255	121	13420	101	13515	99	14445	105
10043	96	11420	100	13256	121	13421	101	13516	99	14446	105
10045	96	11425	100	13257	121	13422	101	13517	99	14450	105
10048	96	11444	100	13258	121	13423	101	13518	99	14451	105
10110	96	11445	100	13259	121	13424	101	13519	99	14455	105
10120	96	12010	99	13260	120	13425	101	13520	99	14456	105
10130	96	12020	99	13261	117	13426	101	13521	99	14457	105
10330	96	12030	99	13262	117	13427	101	13522	99	14458	105
10332	96	12050	99	13263	117	13428	101	13523	99	14471	105
10334	96	12110	99	13264	116	13429	101	13524	99	14472	105
10336	96	12120	99	13265	116	13430	101	13525	99	14473	105
10430	97	12130	99	13266	116	13431	101	13526	99	14474	105
10450	97	12150	99	13267	117	13432	101	13527	99	14480	104
10490	97	12220	99	13268	116	13433	101	13528	99	14485	109
10996	97	12230	99	13269	116	13434	101	13529	99	14485	271
10998	97	12250	99	13270	116	13435	101	13530	99	14486	109
10999	97	12433	100	13271	116	13436	101	13531	99	14486	271
11002	99	12435	100	13272	116	13437	101	13532	99	14490	105
11003	99	13010	101	13273	116	13438	101	13533	99	14491	105
11005	99	13020	101	13274	116	13439	101	13534	99	14492	105
11006	99	13021	101	13275	116	13440	101	14001	102	14493	105
11007	99	13022	101	13276	117	13441	101	14002	102	14494	105
11008	99	13023	101	13277	120	13442	101	14003	102	15003	107
11082	99	13111	101	13278	116	13443	101	14004	102	15004	107
11083	99	13120	101	13279	117	13444	101	14006	102	15005	107
11085	99	13200	118	13280	117	13445	101	14007	102	15006	107
11102	98	13201	118	13281	102	13446	101	14008	102	15008	107
11103	98	13202	118	13282	102	13447	101	14009	102	15010	107
11105	98	13205	119	13284	117	13448	101	14010	103	15012	107
11106	98	13206	119	13285	102	13449	101	14011	103	15015	107
11107	98	13207	119	13288	117	13450	101	14012	103	15018	107
11110	98	13208	119	13290	217	13451	101	14013	102	15020	107
11200	99	13211	101	13293	217	13452	101	14015	103	15033	106
11201	99	13212	119	13294	217	13453	101	14017	103	15034	106
11202	99	13214	118	13295	120	13454	101	14019	103	15035	106
11204	99	13216	118	13296	120	13455	101	14025	105	15036	106
11205	99	13217	118	13350	121	13456	101	14030	103	15037	106
11206	99	13218	118	13351	121	13457	101	14035	102	15039	106
11207	99	13219	118	13352	121	13458	101	14040	102	15103	107
11208	99	13220	101	13353	121	13459	101	14045	102	15104	107
11209	99	13222	118	13354	121	13460	101	14060	103	15105	107
11210	99	13223	118	13355	121	13461	101	14070	103	15106	107
11220	98	13224	118	13360	121	13462	101	14075	103	15108	107
11221	98	13225	118	13361	121	13463	101	14077	103	15110	107
11226	98	13226	118	13362	121	13464	101	14080	102	15112	107
11239	98	13227	118	13363	121	13465	101	14090	104	15115	107
11259	98	13228	118	13364	121	13466	101	14091	104	15118	107
11260	98	13229	118	13365	121	13467	101	14220	105	15120	107
11311	100	13230	118	13399	101	13468	101	14225	105	15204	107
11312	100	13231	118	13400	101	13469	101	14230	105	15205	107
11313	100	13235	118	13401	101	13470	101	14235	105	15206	107
11314	100	13236	118	13402	101	13471	101	14240	105	15208	107
11323	98	13237	118	13403	101	13472	101	14250	105	15210	107
11325	98	13238	118	13404	101	13473	101	14350	105	15212	107
11327	98	13240	120	13405	101	13500	99	14360	105	15215	107
11333	98	13241	120	13406	101	13501	99	14370	105	15218	107
11335	98	13242	120	13407	101	13502	99	14380	105	15220	107
11337	98	13243	120	13408	101	13503	99	14399	105	15230	107
11338	98	13244	120	13409	101	13504	99	14410	105	15235	108
11343	98	13245	120	13410	101	13505	99	14411	105	15301	109
11345	98	13246	119	13411	101	13506	99	14415	104	15301	271
11347	98	13247	119	13412	101	13507	99	14417	104	15310	108
11353	98	13248	119	13413	101	13508	99	14418	104	15310	270

REJESTR ARTYKUŁÓW



kod produktu	str.	kod produktu	str.	kod produktu	str.	kod produktu	str.	kod produktu	str.	kod produktu	str.
15315	108	15810	109	16003	122	16075	130	16300	139	17037	137
15315	270	15810	271	16004	122	16077	130	16301	139	17038	177
15318	108	15812	109	16005	122	16078	130	16303	139	17039	176
15318	270	15812	271	16006	122	16081	130	16304	139	17040	174
15320	108	15815	109	16010	122	16082	129	16305	138	17041	174
15320	270	15815	271	16010	122	16083	131	16306	138	17042	174
15325	108	15818	109	16011	122	16084	131	16307	138	17043	174
15325	270	15818	271	16011	122	16085	126	16308	138	17044	174
15330	108	15820	109	16011	122	16086	126	16309	138	17045	174
15330	270	15820	271	16012	122	16087	127	16310	139	17046	177
15335	108	15825	109	16012	122	16090	125	16310	139	17047	172
15335	270	15825	271	16012	122	16091	125	16311	139	17048	177
15340	108	15830	109	16013	122	16095	127	16311	139	17049	177
15340	270	15830	271	16013	122	16099	124	16311	139	17050	139
15415	108	15850	109	16016	122	16100	124	16312	139	17050	181
15415	270	15850	271	16017	122	16105	124	16312	139	17051	177
15418	108	15853	109	16019	122	16110	124	16315	137	17052	177
15418	270	15853	271	16021	128	16115	124	16315	137	17053	177
15420	108	15855	109	16023	127	16120	124	16319	139	17054	177
15420	270	15855	271	16024	128	16125	124	16320	139	17055	177
15425	108	15860	109	16025	125	16130	126	16321	139	17056	177
15425	270	15860	271	16026	128	16131	124	16321	229	17057	177
15430	108	15870	109	16028	128	16135	126	16401	181	17058	177
15430	270	15870	271	16029	125	16136	125	16405	181	17059	176
15510	108	15880	109	16030	128	16137	125	16406	181	17060	176
15510	270	15880	271	16031	128	16140	126	16407	181	17061	176
15515	108	15885	256	16032	128	16141	128	16408	181	17062	176
15515	270	15886	256	16033	127	16142	125	16420	181	17063	175
15518	108	15886	349	16034	126	16143	125	16500	176	17064	175
15518	270	15887	256	16035	127	16144	125	16501	176	17065	175
15520	108	15887	349	16036	129	16145	125	16502	176	17066	175
15520	270	15888	256	16037	127	16146	125	16990	136	17067	175
15525	108	15888	349	16039	127	16147	126	16990	320	17068	175
15525	270	15889	256	16041	129	16150	125	16991	136	17069	175
15530	108	15893	109	16042	129	16151	125	16991	320	17070	175
15530	270	15893	271	16042	279	16198	131	16998	122	17071	175
15535	108	15894	109	16043	128	16199	131	16999	122	17072	175
15535	270	15894	271	16044	126	16201	132	17001	171	17075	175
15540	108	15895	109	16046	128	16202	173	17002	171	17076	175
15540	270	15895	271	16049	129	16205	173	17003	171	17077	175
15615	108	15904	111	16050	129	16206	173	17004	171	17078	177
15615	270	15906	111	16051	129	16208	173	17005	171	17079	176
15620	108	15908	111	16052	129	16209	133	17006	171	17080	176
15620	270	15910	111	16053	128	16209	365	17007	171	17081	176
15625	108	15912	111	16054	129	16210	132	17008	171	17082	176
15625	270	15915	111	16055	128	16211	132	17009	171	17083	178
15630	108	15920	111	16056	278	16212	132	17010	171	17084	176
15630	270	15954	111	16057	126	16218	133	17011	171	17085	176
15710	109	15956	111	16058	126	16219	133	17012	176	17086	176
15710	270	15958	111	16059	129	16220	133	17013	176	17087	172
15715	109	15960	111	16060	130	16221	133	17014	176	17089	178
15715	270	15962	111	16061	130	16222	133	17015	178	17090	178
15720	109	15965	111	16062	130	16223	133	17016	178	17091	178
15720	270	15970	111	16063	130	16224	134	17017	178	17092	178
15725	109	15980	111	16064	130	16225	132	17019	178	17093	178
15725	270	15981	111	16065	130	16226	134	17020	177	17094	171
15730	109	15983	100	16066	124	16227	134	17021	177	17095	171
15730	270	15985	100	16066	130	16228	134	17022	177	17096	171
15735	109	15988	100	16067	130	16229	132	17023	175	17097	171
15735	270	15989	100	16068	130	16230	132	17024	171	17098	171
15740	109	15990	111	16069	129	16231	132	17025	174	17099	171
15740	270	15991	111	16070	129	16231	135	17026	137	17100	171
15754	110	15992	111	16070	131	16232	134	17027	137	17101	169
15756	110	15993	111	16071	127	16232	174	17028	177	17102	169
15758	110	15996	110	16071	130	16234	132	17029	176	17103	169
15760	110	15997	110	16072	130	16235	133	17033	176	17104	169
15762	110	15998	110	16073	131	16236	133	17034	175	17105	169
15768	110	15999	110	16074	126	16281	127	17035	175	17108	171
15770	110	16002	122	16074	131	16282	127	17036	175	17109	175

kod produktu str.	kod produktu str.	kod produktu str.	kod produktu str.	kod produktu str.	kod produktu str.
17110	171	17238	156	17393	160
17111	179	17240	158	17394	160
17112	179	17241	158	17395	160
17113	179	17242	158	17396	160
17116	179	17243	158	17397	160
17117	179	17244	158	17398	160
17121	179	17245	155	17400	161
17122	179	17247	153	17401	160
17125	172	17250	161	17402	160
17126	172	17255	161	17405	160
17127	172	17259	153	17406	160
17128	172	17260	153	17407	160
17130	172	17261	167	17410	160
17133	172	17262	167	17411	160
17135	172	17292	158	17412	160
17137	172	17294	158	17413	160
17138	172	17295	158	17414	160
17140	169	17296	158	17415	160
17142	169	17297	158	17416	160
17145	169	17298	158	17420	160
17146	169	17299	158	17421	160
17148	169	17300	178	17422	160
17150	175	17301	178	17427	161
17151	175	17302	178	17450	167
17158	181	17303	178	17451	167
17159	181	17304	178	17452	167
17160	181	17305	178	17454	168
17165	179	17306	178	17455	161
17167	179	17308	159	17455	168
17169	179	17309	159	17456	168
17170	179	17310	159	17458	168
17172	178	17311	159	17459	168
17175	180	17312	159	17460	164
17177	180	17313	159	17461	164
17178	172	17314	159	17462	164
17180	172	17315	159	17463	164
17181	172	17316	159	17464	164
17182	45	17317	159	17465	164
17182	137	17318	159	17467	164
17183	45	17319	159	17468	164
17183	137	17320	159	17469	164
17185	181	17321	159	17470	164
17186	180	17322	159	17471	164
17187	181	17324	159	17472	164
17188	181	17327	159	17473	164
17189	181	17330	159	17475	166
17190	174	17332	159	17476	166
17191	174	17333	159	17480	164
17192	174	17334	159	17481	164
17193	174	17338	167	17482	164
17197	165	17341	178	17483	164
17198	165	17342	178	17484	164
17199	165	17350	162	17485	164
17200	165	17351	162	17486	164
17201	165	17352	162	17487	164
17202	165	17353	162	17488	164
17203	167	17357	162	17489	164
17204	167	17359	162	17490	164
17205	167	17361	162	17491	164
17206	167	17380	161	17492	164
17229	155	17381	161	17493	164
17230	155	17382	160	17494	164
17231	155	17383	160	17495	164
17233	155	17384	160	17496	164
17234	155	17385	160	17501	166
17235	156	17386	160	17506	165
17236	156	17390	160	17508	165
17237	154	17391	160	17512	166
17238	153	17392	160	17526	165
				17528	165
				17532	166
				17533	166
				17534	166
				17539	165
				17548	164
				17549	164
				17550	164
				17551	164
				17552	164
				17553	164
				17554	164
				17555	164
				17556	164
				17557	164
				17558	164
				17559	164
				17560	164
				17561	164
				17562	164
				17563	164
				17564	164
				17565	164
				17566	164
				17567	164
				17568	164
				17569	164
				17570	164
				17571	164
				17572	164
				17573	164
				17574	164
				17575	164
				17576	164
				17577	164
				17578	164
				17579	164
				17580	164
				17581	164
				17582	164
				17583	164
				17584	164
				17585	164
				17586	164
				17587	164
				17589	164
				17590	164
				17591	164
				17592	164
				17593	164
				17600	167
				17601	167
				17603	167
				17605	164
				17606	164
				17607	164
				17608	164
				17609	164
				17610	164
				17611	164
				17612	164
				17613	164
				17614	164
				17615	164
				17616	164
				17617	164
				17619	165
				17620	166
				17621	166
				17622	164
				17623	164
				17624	164
				17625	164
				17626	164
				17628	164
				17629	164
				17630	164
				17631	164
				17632	164
				17633	164
				17640	166
				17642	166
				17643	166
				17644	166
				17645	166
				17650	166
				17651	166
				17652	166
				17653	166
				17654	166
				17655	166
				17656	166
				17657	166
				17658	166
				17659	166
				17660	164
				17661	164
				17662	164
				17663	164
				17664	164
				17665	164
				17666	164
				17667	164
				17668	164
				17669	164
				17670	164
				17671	164
				17672	164
				17674	164
				17675	164
				17676	164
				17677	164
				17678	164
				17679	164
				17680	168
				17681	168
				17682	168
				17683	164
				17685	165
				17761	164
				17769	164
				17788	164
				17795	164
				17806	164
				17810	161
				17811	161
				17812	161
				17820	159
				17821	159
				17822	159
				17823	159
				17824	159
				17825	159
				17826	159
				17827	159
				17828	159
				17829	159
				17830	159
				17831	159
				17832	159
				17835	159
				17836	159
				17837	159
				17838	159
				17839	159
				17840	159
				17841	159
				17842	159
				17843	159
				17844	159
				17845	159
				17846	159
				17847	159
				17848	159
				17849	159
				17850	159
				17851	159
				17852	159
				17853	159
				17854	159
				17855	159
				17856	159
				17860	159
				17861	159
				17862	159
				17863	159
				17864	159
				17865	159
				17866	159
				17867	159
				17868	159
				17869	159
				17870	159
				17871	159
				17872	159
				17873	159
				17874	159
				17875	159
				17876	159
				17877	159
				17878	159
				17879	159
				17880	159
				17881	159
				17882	159
				17883	159
				17884	159
				17885	159
				17886	159
				17887	159
				17888	159
				17889	159
				17890	159
				17891	159
				17892	159
				17895	159
				17896	159
				17897	159
				17898	159
				17904	159
				17905	159
				17907	159
				17910	159
				17914	159
				17916	159
				17922	159
				17924	159

REJESTR ARTYKUŁÓW



kod produktu str.	kod produktu str.	kod produktu str.	kod produktu str.	kod produktu str.	kod produktu str.
17926	159	18302	143	18498	163
17930	159	18303	143	18499	163
17934	159	18304	143	18500	163
17935	159	18310	140	18501	162
17943	159	18311	140	18508	163
17944	159	18312	140	18510	162
17970	148	18313	140	18511	162
17971	148	18321	140	18512	162
17972	148	18322	140	18513	162
17973	148	18340	141	18514	162
17974	148	18350	140	18515	162
17975	148	18351	140	18516	162
17976	148	18352	140	18518	162
17980	148	18353	140	18519	162
17981	148	18354	140	18520	162
17982	148	18355	140	18521	162
17983	148	18356	140	18522	162
18062	142	18357	140	18523	162
18063	142	18358	140	18524	162
18064	142	18359	140	18527	162
18065	142	18360	140	18567	162
18066	142	18400	143	18572	162
18067	142	18401	143	18575	162
18070	142	18402	141	18576	162
18071	142	18403	141	18577	162
18072	142	18404	141	18578	162
18075	142	18408	145	18579	162
18076	142	18409	145	18580	162
18077	142	18410	142	18581	162
18080	142	18411	142	18582	162
18081	142	18413	142	18583	162
18082	142	18415	144	18584	162
18083	142	18416	144	18585	162
18084	142	18417	144	18587	162
18085	142	18418	143	18588	162
18086	142	18419	144	18589	162
18087	142	18420	144	18593	162
18088	142	18421	152	18600	149
18089	142	18422	141	18601	149
18090	142	18423	142	18602	149
18091	142	18424	141	18603	158
18092	142	18425	140	18604	161
18101	143	18426	145	18605	149
18102	143	18427	145	18607	149
18103	143	18428	115	18608	144
18104	143	18429	115	18609	150
18105	143	18430	152	18610	150
18106	143	18431	144	18611	150
18107	143	18432	146	18612	150
18108	143	18433	144	18613	150
18110	143	18434	140	18614	150
18113	140	18435	145	18615	150
18114	140	18437	145	18618	150
18115	140	18440	152	18619	149
18116	140	18445	173	18619	161
18118	140	18450	143	18620	147
18120	140	18451	143	18621	147
18124	140	18455	143	18623	147
18125	140	18456	143	18625	147
18201	143	18460	143	18627	147
18202	143	18476	162	18628	147
18203	143	18490	163	18630	147
18204	143	18491	163	18631	147
18210	140	18492	163	18632	147
18211	140	18493	163	18633	147
18212	140	18494	162	18634	147
18215	140	18495	162	18635	147
18216	140	18496	163	18636	147
18301	143	18497	163	18637	147
				18638	147
				18639	147
				18640	147
				18641	147
				18645	147
				18646	147
				18680	147
				18685	147
				18710	146
				18711	146
				18712	146
				18715	146
				18716	146
				18717	146
				18720	146
				18721	146
				18722	146
				18723	146
				18724	146
				18725	146
				18750	147
				18751	147
				18753	147
				18755	147
				18760	147
				18761	147
				18762	147
				18763	147
				18764	147
				18765	147
				18766	147
				18767	147
				18768	147
				18769	147
				18770	147
				18771	147
				18772	147
				18775	147
				18776	147
				18777	147
				18795	149
				18796	149
				18797	149
				18798	149
				18799	149
				18800	148
				18801	148
				18802	148
				18803	148
				18804	148
				18805	148
				18806	148
				18807	148
				18810	148
				18811	148
				18812	148
				18813	148
				18814	148
				18815	148
				18816	148
				18817	148
				18820	148
				18821	148
				18822	148
				18823	148
				18824	148
				18825	148
				18826	148
				18827	148
				18828	148
				18829	148
				18830	148
				18831	148
				18832	148
				18835	148
				18836	148
				18837	148
				18838	148
				18839	148
				18840	148
				18841	148
				18842	148
				18843	148
				18844	148
				18845	148
				18846	148
				18847	148
				18850	148
				18851	148
				18852	148
				18853	148
				18855	148
				18856	148
				18860	148
				18861	148
				18862	148
				18863	148
				18864	148
				18865	148
				18866	148
				18867	148
				18868	148
				18869	148
				18870	148
				18871	148
				18872	148
				18873	148
				18874	148
				18900	151
				18901	151
				18905	151
				18906	151
				18907	152
				18908	151
				18909	151
				18910	145
				18915	152
				18920	160
				18921	160
				18922	160
				18925	160
				18926	160
				18927	160
				18928	160
				18929	160
				18930	160
				18931	160
				18934	160
				18939	160
				18948	160
				18950	160
				18951	160
				18954	160
				18955	160
				18956	160
				18960	160
				18961	160
				18963	160
				18971	160
				18993	150
				18994	150
				19001	197
				19002	197
				19003	197
				19004	197
				19005	197
				19006	197
				19008	197
				19010	197
				19015	197
				19020	197
				19021	195
				19022	195
				19023	195
				19024	195
				19025	195
				19026	195
				19028	195
				19030	195
				19031	195
				19032	195
				19034	195
				19036	195
				19041	195
				19042	195
				19043	195
				19044	195
				19045	195
				19046	195
				19050	197
				19051	197
				19052	197
				19053	197
				19054	197
				19055	197
				19056	197
				19057	197
				19058	195
				19059	195
				19060	196
				19061	196
				19062	196
				19063	196
				19064	196
				19065	196
				19066	195
				19067	195
				19068	195
				19069	195
				19070	195
				19071	195
				19074	195
				19075	195
				19076	195
				19077	195
				19081	195
				19082	195
				19083	195
				19084	195
				19085	195
				19086	195
				19088	195
				19090	195
				19092	195
				19095	195
				19096	195
				19097	195

kod produktu	str.	kod produktu	str.	kod produktu	str.	kod produktu	str.	kod produktu	str.	kod produktu	str.
19098	195	19394	317	19473	202	19580	56	19643	56	19704	57
19100	196	19395	317	19474	202	19585	56	19644	56	19705	57
19106	195	19396	317	19477	202	19585	56	19645	56	19705	57
19108	195	19397	317	19478	202	19586	56	19645	56	19706	57
19109	195	19398	197	19480	202	19587	56	19646	56	19707	57
19110	200	19399	197	19481	202	19588	56	19647	56	19708	57
19115	44	19400	201	19483	202	19589	56	19648	56	19708	57
19115	197	19400	251	19485	201	19590	56	19649	56	19709	57
19124	196	19401	201	19486	201	19590	56	19650	56	19710	57
19136	196	19401	251	19487	201	19591	56	19650	56	19711	57
19148	196	19402	201	19490	135	19593	56	19651	56	19711	57
19149	196	19402	251	19491	135	19594	56	19652	56	19712	57
19150	196	19403	201	19492	135	19595	56	19653	56	19713	57
19151	196	19403	251	19493	135	19595	56	19654	56	19713	57
19202	198	19404	201	19494	135	19596	56	19655	56	19714	57
19208	199	19404	251	19495	135	19597	56	19656	56	19715	57
19209	199	19405	201	19496	135	19598	56	19657	56	19716	57
19211	199	19405	251	19497	135	19599	56	19658	56	19717	57
19245	198	19406	201	19498	135	19600	56	19659	56	19718	57
19246	198	19406	251	19499	135	19600	56	19660	56	19718	57
19247	198	19407	201	19501	135	19601	56	19661	56	19719	57
19248	198	19407	251	19502	135	19603	56	19662	56	19720	57
19249	198	19408	201	19510	134	19604	56	19663	56	19721	57
19251	199	19408	251	19515	134	19605	56	19664	56	19722	57
19252	199	19409	201	19520	134	19605	56	19665	56	19723	57
19253	199	19409	251	19530	56	19606	56	19669	56	19723	57
19254	199	19410	201	19530	56	19607	56	19670	57	19724	57
19255	199	19411	201	19535	56	19608	56	19671	57	19725	57
19265	199	19412	201	19535	56	19609	56	19672	57	19726	57
19270	199	19415	200	19536	56	19610	56	19673	57	19727	57
19271	199	19416	200	19537	56	19610	56	19673	57	19728	57
19272	199	19418	201	19538	56	19611	56	19674	57	19728	57
19281	199	19419	201	19539	56	19612	56	19675	57	19729	57
19290	199	19420	200	19540	56	19613	56	19676	57	19730	57
19293	199	19421	200	19540	56	19614	56	19677	57	19731	57
19294	199	19422	200	19543	56	19615	56	19678	57	19732	57
19295	199	19423	200	19544	56	19615	56	19678	57	19733	57
19297	199	19424	200	19545	56	19616	56	19679	57	19733	57
19301	316	19425	200	19545	56	19617	56	19680	57	19734	57
19303	196	19426	200	19550	56	19618	56	19681	57	19735	57
19306	317	19427	200	19550	56	19619	56	19682	57	19736	57
19308	317	19429	201	19552	56	19620	56	19683	57	19737	57
19310	317	19430	197	19552	56	19620	56	19683	57	19738	57
19312	317	19431	197	19554	56	19621	56	19684	57	19738	57
19314	317	19432	197	19555	56	19622	56	19685	57	19739	57
19326	316	19433	197	19555	56	19623	56	19686	57	19740	57
19328	316	19434	197	19557	56	19624	56	19687	57	19741	57
19330	316	19435	197	19558	56	19625	56	19688	57	19742	57
19332	316	19436	201	19559	56	19625	56	19688	57	19743	57
19333	316	19440	197	19560	56	19626	56	19689	57	19743	57
19335	316	19441	197	19560	56	19627	56	19690	57	19744	57
19337	316	19442	197	19562	56	19628	56	19691	57	19745	57
19340	316	19443	197	19562	56	19629	56	19692	57	19746	57
19370	317	19450	135	19564	56	19630	56	19693	57	19747	57
19371	317	19451	135	19565	56	19630	56	19693	57	19748	57
19374	317	19455	135	19565	56	19631	56	19694	57	19748	57
19380	316	19457	135	19567	56	19632	56	19695	57	19749	57
19381	316	19458	135	19568	56	19633	56	19695	57	19750	57
19382	316	19459	135	19568	56	19634	56	19696	57	19751	57
19383	316	19460	201	19570	56	19635	56	19697	57	19752	57
19384	316	19460	251	19570	56	19635	56	19698	57	19753	57
19385	316	19462	317	19574	56	19636	56	19698	57	19753	57
19387	316	19463	317	19575	56	19637	56	19699	57	19754	57
19388	316	19464	317	19575	56	19638	56	19700	57	19755	57
19389	316	19465	317	19576	56	19639	56	19701	57	19756	57
19390	316	19469	317	19577	56	19640	56	19701	57	19757	57
19391	316	19470	201	19578	56	19640	56	19702	57	19758	57
19392	316	19470	251	19579	56	19641	56	19703	57	19758	57
19393	317	19472	202	19580	56	19642	56	19703	57	19759	57

kod produktu	str.	kod produktu	str.	kod produktu	str.	kod produktu	str.	kod produktu	str.	kod produktu	str.
19760	57	20300	59	20489	61	20751	67	20896	63	21110	75
19761	57	20305	59	20490	61	20752	67	20897	63	21111	75
19762	57	20310	59	20491	61	20753	67	20898	63	21112	75
19763	57	20311	59	20492	61	20754	67	20899	63	21115	75
19763	57	20315	60	20493	61	20755	67	20901	64	21118	75
19764	57	20316	59	20494	61	20756	67	20905	64	21123	75
19765	57	20317	59	20495	61	20757	67	20910	64	21130	75
19766	57	20320	60	20496	61	20758	67	20911	63	21135	75
19767	57	20321	60	20508	67	20759	67	20912	63	21140	75
19768	57	20333	58	20510	67	20760	67	20913	63	21150	75
19768	57	20334	58	20511	67	20761	67	20915	63	21180	75
19769	57	20335	58	20512	67	20762	67	20916	63	21190	75
19770	57	20336	58	20513	67	20764	67	20917	63	21192	77
19771	57	20337	58	20514	67	20765	67	20918	63	21194	77
19772	57	20338	58	20515	67	20766	67	20919	63	21195	75
19772	57	20340	60	20516	67	20767	67	20920	63	21200	74
19773	57	20350	202	20520	67	20768	67	20921	63	21201	74
19774	57	20360	139	20521	67	20769	67	20922	63	21203	74
19775	57	20361	139	20522	67	20770	67	20923	63	21204	74
19776	57	20363	180	20523	67	20771	67	20924	63	21205	74
19776	57	20364	180	20524	67	20772	67	20932	69	21209	74
19777	57	20365	29	20525	67	20773	67	20936	69	21210	75
19778	57	20379	29	20526	67	20774	67	20937	69	21211	75
19779	57	20380	60	20673	67	20775	67	20938	69	21212	75
19780	57	20381	64	20674	67	20776	67	20939	69	21215	75
19781	57	20385	62	20675	67	20777	67	20940	69	21218	75
19781	57	20386	62	20676	67	20778	67	20941	69	21219	75
19782	57	20387	62	20677	67	20779	67	20942	69	21220	75
19783	57	20390	62	20678	67	20780	67	20943	69	21223	75
19783	57	20391	62	20680	67	20781	67	20944	69	21224	75
19784	57	20394	62	20682	67	20782	67	20945	69	21230	74
19785	57	20395	62	20684	67	20783	67	20946	69	21231	74
19786	57	20396	62	20685	67	20784	67	20947	69	21234	74
19786	57	20397	62	20686	67	20785	67	20948	69	21235	74
19787	57	20400	58	20687	67	20786	67	20949	69	21238	74
19788	57	20401	58	20688	67	20787	67	20950	68	21301	75
19789	57	20402	58	20690	67	20788	67	20952	68	21303	75
19790	57	20403	58	20691	67	20789	67	20954	68	21306	77
19791	57	20404	58	20692	67	20790	67	20956	69	21308	77
19792	57	20405	58	20694	67	20791	67	20957	63	21311	75
19793	57	20406	58	20696	67	20792	67	20958	63	21312	75
19794	57	20407	58	20697	67	20793	67	20960	29	21315	75
19795	57	20408	58	20698	67	20794	67	20961	29	21318	75
19796	57	20409	58	20724	63	20795	67	20963	29	21323	75
19797	57	20410	58	20725	63	20796	67	20965	29	21324	75
19798	57	20411	58	20726	63	20797	67	20966	29	21326	75
19799	57	20412	58	20727	63	20798	67	20967	166	21327	75
19800	57	20413	58	20728	63	20799	67	20968	166	21411	75
19801	57	20414	58	20729	63	20805	68	20970	202	21412	75
19802	57	20415	58	20730	63	20820	68	20971	202	21415	75
19841	58	20416	58	20731	63	20825	67	20972	202	21418	75
19842	58	20417	58	20732	63	20855	67	20973	202	21423	75
19845	58	20418	58	20733	63	20861	67	20980	63	21424	75
19885	58	20419	58	20734	63	20862	67	20981	63	21425	76
19895	58	20420	58	20735	63	20870	67	20982	63	21426	76
20210	64	20421	58	20736	63	20871	67	20983	63	21427	76
20220	57	20422	58	20737	63	20872	67	20984	63	21428	76
20225	57	20423	58	20738	63	20873	67	20990	69	21430	76
20230	57	20424	58	20739	63	20874	67	20991	69	21431	76
20235	57	20425	58	20740	63	20875	67	20992	69	21432	76
20240	57	20426	58	20741	63	20876	67	20996	68	21435	76
20245	57	20427	58	20742	150	20877	67	20997	69	21436	76
20250	57	20428	58	20743	29	20878	67	20999	68	21437	76
20255	57	20429	58	20743	149	20879	67	21010	75	21440	64
20260	57	20430	58	20744	29	20880	67	21011	75	21441	64
20270	57	20450	64	20745	29	20881	67	21012	75	21442	64
20280	57	20460	64	20748	67	20890	68	21015	75	21443	64
20290	57	20487	61	20749	67	20891	68	21018	75	21444	64
20296	57	20488	61	20750	67	20895	68	21023	75	21445	64

kod produktu	str.	kod produktu	str.	kod produktu	str.	kod produktu	str.	kod produktu	str.	kod produktu	str.
21446	64	21803	78	22012	81	22083	82	22170	189	22277	76
21450	66	21804	78	22013	81	22084	82	22171	189	22280	76
21451	66	21805	78	22014	81	22085	82	22172	189	22281	76
21452	66	21806	78	22015	81	22086	187	22173	189	22285	76
21453	66	21807	65	22016	81	22087	83	22174	189	22286	76
21454	66	21807	78	22017	81	22088	82	22178	188	22294	76
21530	64	21808	65	22018	81	22090	82	22180	188	22300	86
21531	63	21808	78	22019	81	22091	83	22181	188	22301	86
21532	63	21809	79	22020	81	22092	83	22182	188	22302	86
21533	63	21810	84	22021	81	22093	83	22183	188	22303	86
21534	63	21811	84	22022	81	22095	82	22184	188	22305	86
21535	63	21812	84	22023	81	22096	84	22185	188	22307	86
21536	63	21813	84	22024	81	22097	84	22186	188	22309	86
21540	66	21814	84	22025	81	22098	84	22188	189	22310	86
21541	66	21831	84	22026	81	22099	84	22189	189	22311	86
21701	84	21832	84	22027	81	22100	85	22190	189	22312	86
21702	84	21834	84	22028	81	22101	85	22196	189	22313	86
21703	84	21850	85	22029	81	22102	85	22197	189	22314	86
21704	84	21851	85	22030	81	22103	85	22198	189	22315	86
21705	84	21852	85	22031	81	22104	85	22199	189	22316	86
21706	84	21853	85	22032	82	22105	85	22200	70	22317	86
21709	84	21854	85	22033	187	22106	85	22201	70	22318	86
21715	84	21855	85	22034	187	22107	85	22202	189	22319	86
21716	84	21856	85	22035	187	22108	85	22203	189	22320	86
21717	84	21857	85	22036	187	22109	85	22204	189	22322	86
21718	84	21858	85	22037	80	22110	85	22205	189	22324	86
21719	84	21859	85	22038	80	22111	85	22206	188	22326	86
21720	84	21860	85	22039	81	22112	85	22207	188	22328	86
21721	84	21861	85	22040	81	22113	85	22208	188	22329	86
21724	84	21862	85	22041	83	22115	85	22209	188	22332	86
21732	84	21863	85	22042	83	22116	85	22211	77	22333	86
21734	84	21864	85	22043	83	22117	85	22212	77	22335	86
21735	84	21900	80	22044	83	22119	85	22215	77	22337	86
21736	84	21901	80	22045	84	22120	293	22216	77	22340	86
21737	84	21902	80	22046	84	22121	293	22217	77	22343	86
21740	84	21903	80	22047	84	22122	293	22218	77	22345	86
21741	84	21904	80	22048	84	22123	293	22219	77	22350	86
21742	84	21905	80	22049	84	22124	293	22220	77	22351	86
21743	84	21906	80	22050	84	22125	293	22222	77	22355	86
21744	84	21907	80	22051	84	22126	293	22224	77	22357	86
21750	84	21908	80	22052	84	22129	293	22225	77	22365	86
21751	84	21909	81	22053	84	22130	293	22228	77	22370	86
21752	84	21910	81	22054	84	22132	293	22229	77	22398	86
21753	84	21911	80	22055	84	22133	293	22230	77	22399	86
21754	84	21912	80	22056	84	22134	293	22232	77	22510	56
21760	79	21913	80	22057	84	22135	350	22234	77	22515	56
21761	79	21914	80	22058	81	22136	350	22236	77	22520	56
21762	79	21920	80	22059	81	22137	350	22238	77	22525	56
21763	79	21925	80	22060	83	22138	350	22240	77	22530	56
21764	79	21926	80	22061	83	22140	79	22242	77	22532	56
21780	79	21930	82	22062	83	22141	79	22244	77	22535	56
21781	79	21931	82	22063	83	22142	79	22246	77	22540	56
21782	79	21935	82	22064	83	22143	79	22248	77	22542	56
21783	79	21936	82	22065	83	22145	79	22251	77	22545	56
21784	79	21937	82	22066	83	22146	79	22252	77	22548	56
21786	79	21940	82	22067	85	22147	79	22253	77	22550	56
21787	79	21941	82	22070	83	22148	79	22254	77	22555	56
21788	79	21950	81	22071	83	22150	79	22255	77	22560	56
21789	79	22001	80	22072	83	22151	79	22258	76	22565	56
21790	79	22002	80	22073	83	22155	79	22259	76	22568	56
21792	79	22003	80	22074	83	22156	79	22260	76	22570	56
21793	79	22004	80	22075	85	22158	187	22263	76	22575	56
21794	79	22005	80	22076	85	22159	187	22264	76	22580	56
21795	79	22006	80	22077	85	22160	83	22266	76	22585	56
21796	79	22007	80	22078	187	22161	83	22269	76	22590	56
21798	79	22008	80	22079	187	22162	83	22270	76	22595	56
21800	78	22009	80	22080	187	22163	83	22273	76	22600	56
21801	78	22010	80	22081	187	22164	83	22274	76	22602	56
21802	78	22011	80	22082	187	22167	83	22275	76	22605	56

REJESTR ARTYKUŁÓW



kod produktu	str.	kod produktu	str.	kod produktu	str.	kod produktu	str.	kod produktu	str.	kod produktu	str.
22610	56	23658	209	23973	183	24111	190	24197	93	24676	72
22615	56	23660	210	23974	183	24114	191	24301	90	24677	72
22620	56	23661	209	23975	183	24115	191	24302	90	24678	72
22625	56	23664	209	23976	183	24118	93	24303	90	24680	276
22630	56	23670	203	23977	183	24119	93	24304	90	24690	202
22701	82	23671	203	23978	183	24120	93	24305	90	24691	202
22702	82	23672	203	23979	183	24121	190	24306	90	24695	202
22703	82	23673	203	23985	183	24122	190	24308	90	24700	72
22704	82	23674	203	23986	183	24124	190	24310	90	24701	72
22705	82	23675	203	23987	183	24125	190	24312	91	24702	72
22706	82	23676	203	23988	183	24126	190	24313	91	24703	72
22707	82	23677	203	23989	183	24128	193	24314	91	24704	72
23270	239	23678	203	24000	183	24130	192	24315	91	24705	72
23400	212	23679	203	24001	183	24131	192	24316	91	24706	65
23401	212	23680	203	24005	183	24132	134	24320	87	24710	73
23402	212	23681	203	24007	182	24133	192	24321	87	24712	65
23406	212	23682	203	24008	183	24134	191	24322	87	24713	65
23407	212	23683	203	24010	182	24135	192	24325	91	24714	65
23410	212	23684	203	24015	182	24136	192	24410	60	24715	65
23411	212	23685	203	24017	182	24137	192	24411	60	24716	65
23412	212	23730	168	24020	182	24140	192	24412	60	24717	69
23415	212	23731	168	24030	182	24141	192	24415	65	24718	69
23416	212	23732	168	24035	183	24142	192	24419	60	24719	69
23417	212	23734	168	24036	183	24143	191	24420	60	24720	65
23420	205	23735	168	24038	183	24144	191	24422	60	24721	65
23506	204	23736	168	24039	183	24145	191	24425	60	24722	65
23507	204	23760	185	24040	183	24147	191	24429	60	24723	69
23508	204	23761	185	24041	183	24148	192	24432	60	24725	70
23515	204	23762	185	24042	183	24149	191	24435	60	24726	70
23520	204	23763	185	24043	183	24150	192	24437	60	24727	290
23525	204	23764	185	24045	89	24151	192	24444	60	24728	290
23530	204	23800	184	24050	91	24152	193	24451	60	24729	290
23531	204	23840	322	24055	88	24152	315	24457	60	24730	69
23551	204	23845	323	24055	277	24153	190	24464	60	24731	69
23560	204	23846	323	24060	88	24155	194	24468	60	24732	69
23561	204	23847	323	24061	88	24156	194	24476	60	24734	73
23562	204	23875	223	24062	88	24158	194	24483	60	24735	70
23563	204	23875	357	24063	88	24159	194	24620	71	24736	70
23564	204	23904	185	24064	88	24159	293	24621	71	24737	70
23565	204	23906	185	24065	88	24160	93	24622	71	24738	70
23566	204	23908	185	24066	88	24161	93	24623	71	24739	70
23570	203	23910	185	24067	88	24162	93	24624	71	24740	70
23571	203	23912	185	24068	88	24163	93	24627	71	24741	70
23572	203	23914	185	24069	88	24164	93	24630	71	24743	70
23573	203	23920	184	24070	88	24165	93	24633	71	24745	70
23574	203	23922	184	24071	88	24166	93	24636	71	24746	70
23585	203	23923	184	24072	88	24167	93	24638	71	24747	70
23587	203	23924	184	24073	88	24168	93	24640	71	24748	70
23589	203	23925	184	24074	88	24169	93	24642	71	24749	70
23591	203	23927	184	24075	88	24170	190	24643	71	24750	61
23595	204	23928	184	24076	88	24171	192	24647	79	24751	61
23598	204	23945	184	24077	88	24173	192	24648	79	24752	290
23600	205	23950	183	24078	88	24174	194	24649	79	24753	290
23601	205	23951	183	24080	89	24175	194	24650	72	24755	66
23602	205	23952	183	24081	89	24176	194	24651	71	24756	66
23605	205	23953	183	24082	89	24177	194	24652	71	24757	69
23607	205	23954	183	24083	89	24178	194	24655	73	24758	69
23620	205	23955	183	24084	89	24180	93	24658	73	24759	69
23625	203	23960	185	24085	89	24181	194	24661	72	24760	72
23626	203	23961	185	24086	89	24185	93	24663	72	24761	72
23628	203	23962	185	24087	89	24186	93	24665	82	24762	72
23630	203	23963	185	24098	89	24187	93	24666	82	24763	72
23632	203	23964	185	24099	89	24188	93	24667	82	24764	72
23635	203	23965	185	24100	190	24189	93	24670	72	24765	72
23637	204	23966	185	24102	190	24190	194	24671	72	24766	72
23650	210	23967	185	24104	190	24190	293	24672	72	24767	72
23652	208	23970	183	24108	93	24192	93	24673	72	24768	72
23655	210	23971	183	24109	93	24195	93	24674	72	24769	72
23657	208	23972	183	24110	190	24196	93	24675	72	24770	70

kod produktu str.	kod produktu str.	kod produktu str.	kod produktu str.	kod produktu str.	kod produktu str.
24771	70	25206	305	28032	11
24772	70	25212	305	28035	13
24773	70	25215	305	28040	12
24774	70	25220	305	28045	12
24775	71	25224	305	28050	14
24776	72	25230	305	28055	14
24777	71	25240	305	28060	17
24778	71	25248	305	28061	17
24779	72	25260	305	28065	17
24780	73	25296	305	28070	10
24781	73	25350	305	28075	15
24782	73	25369	305	28076	18
24783	73	25370	305	28080	19
24784	73	25371	305	28081	19
24785	73	25372	305	28083	19
24786	73	25373	305	28085	19
24787	73	25374	305	28086	19
24788	73	25376	305	28090	20
24789	73	25378	305	28101	21
24790	72	25379	305	28102	20
24791	72	25380	305	28103	20
24792	72	25400	305	28104	21
24793	72	25410	305	28210	28
24794	72	26028	111	28213	28
24795	71	26201	113	28215	27
24796	72	26203	112	28218	28
24797	71	26204	113	28220	25
24798	73	26205	112	28221	23
24799	71	26209	114	28223	28
25001	305	26211	113	28225	24
25002	305	26216	114	28228	28
25003	305	26217	114	28229	28
25004	305	26218	114	28230	26
25005	305	26219	114	28233	28
25006	305	26520	115	28240	36
25009	305	26521	115	28267	29
25012	305	26705	228	28275	50
25015	305	26706	228	28278	50
25016	305	26707	228	28280	50
25020	305	26720	228	28282	50
25024	305	26721	228	28340	37
25025	305	26722	228	28342	37
25030	305	26730	272	28345	37
25040	305	26731	272	28346	37
25048	305	26735	272	30003	256
25060	305	26736	272	30003	259
25096	305	26740	273	30004	256
25150	305	26775	292	30004	259
25153	305	26780	273	30005	256
25155	305	26781	273	30005	259
25160	305	26782	273	30007	256
25162	305	26783	273	30007	259
25163	305	26973	216	31005	245
25164	305	26974	216	31006	245
25167	305	26975	216	31007	245
25169	305	26976	216	31008	245
25170	305	26977	216	31009	245
25171	305	28000	4	31011	245
25179	305	28001	5	31021	245
25180	305	28002	5	31031	245
25181	305	28003	6	31041	245
25182	305	28004	6	31051	245
25183	305	28005	7	31052	245
25184	305	28006	7	31053	245
25186	305	28007	8	31061	245
25188	305	28008	8	31062	245
25189	305	28021	9	31071	245
25190	305	28025	9	31072	245
25195	305	28030	11	31081	245
				31082	245
				31091	244
				31101	244
				31111	244
				31121	244
				31131	244
				31132	244
				31140	244
				31141	244
				31142	244
				31143	244
				31144	244
				31145	244
				31146	244
				31148	244
				31150	245
				31151	245
				31155	245
				31218	247
				31220	246
				31221	246
				31222	246
				31231	246
				31232	246
				31233	246
				31234	246
				31235	246
				31270	246
				31271	246
				31280	246
				31281	246
				31320	247
				31322	247
				31330	246
				31332	246
				31334	246
				31340	246
				31341	246
				31343	246
				31360	246
				31362	246
				31380	246
				31382	246
				31390	246
				31392	246
				31400	246
				31402	246
				31403	246
				31404	246
				31452	253
				31453	253
				31454	253
				31455	247
				31456	247
				31461	248
				31467	248
				31468	248
				31471	248
				31481	248
				31491	248
				31493	248
				31494	248
				31495	248
				31496	248
				31497	252
				31498	248
				31499	248
				31500	248
				31501	252
				31502	252
				31503	252
				31505	247
				31506	247
				31507	247
				31510	247
				31511	247
				31512	247
				31513	247
				31514	247
				31515	247
				31517	247
				31519	252
				31520	249
				31521	249
				31522	249
				31523	249
				31524	249
				31541	249
				31551	249
				31552	249
				31553	249
				31555	249
				31556	249
				31557	249
				31558	249
				31559	249
				31601	253
				31602	253
				31603	253
				31610	249
				31641	253
				31651	253
				31655	253
				32001	250
				32002	250
				32003	250
				32013	250
				32014	250
				32015	250
				32016	250
				32018	250
				32020	250
				32021	250
				32022	253
				32023	253
				32024	250
				32026	250
				32037	251
				32038	251
				32040	253
				32041	253
				32042	253
				32043	253
				32044	253
				32050	253
				32051	253
				32052	253
				32053	253
				32060	250
				32062	250
				32064	250
				32066	250
				32089	251
				32161	248
				32162	248
				32163	248
				32164	248
				32165	248
				32166	248
				32167	248
				32168	248
				32169	248
				32170	247
				32171	248
				32172	248
				32173	247
				32174	248
				32176	248
				32186	248
				32196	248
				32206	248
				32216	248
				32226	248
				32234	248
				32240	248
				32265	250
				32268	251
				32269	251
				32270	250
				32273	250
				32283	250
				32285	250
				32293	250
				32295	251
				32296	251
				32297	251
				32298	251
				32301	251
				32302	251
				32311	255
				32312	254
				32313	251
				32314	254
				32315	255
				32316	255
				32317	254
				32318	255
				32319	255
				32320	254
				32321	255
				32322	255
				32323	255
				32324	255
				32325	255
				32326	255
				32327	254
				32328	255
				32329	254
				32330	255
				32331	255
				32332	254
				32333	254
				32335	255
				32337	254
				32338	254
				33168	254
				33275	296
				34005	256
				34006	256
				34007	256
				34027	255
				34028	255
				34033	260
				34041	256
				34051	256
				34053	256
				34061	256

REJESTR ARTYKUŁÓW

kod produktu	str.	kod produktu	str.	kod produktu	str.	kod produktu	str.	kod produktu	str.	kod produktu	str.
34071	256	34405	258	35082	263	35345	40	36130	277	37115	291
34081	256	34406	259	35085	262	35345	286	36136	277	37117	278
34091	256	34407	259	35086	262	35346	41	36138	277	37119	291
34101	256	34409	259	35087	262	35346	288	36139	277	37120	291
34111	256	34410	259	35091	262	35347	41	36140	277	37121	296
34115	256	34411	259	35092	262	35347	288	36145	274	37122	296
34116	256	34412	259	35093	262	35348	40	36160	274	37123	364
34117	256	34413	259	35094	263	35348	286	36175	274	37124	364
34121	256	34414	259	35095	263	35360	46	36190	274	37125	282
34122	256	34415	258	35096	263	35361	46	36191	274	37126	282
34132	256	34416	258	35103	264	35362	46	36195	277	37127	282
34142	256	34417	259	35113	264	35500	266	36199	274	37129	364
34152	256	34418	259	35123	264	35501	266	36200	274	37130	281
34153	256	34419	258	35125	264	35502	266	36300	209	37131	281
34154	256	34420	258	35126	264	35503	266	36308	292	37132	281
34155	256	34421	259	35127	264	35504	266	36310	273	37135	231
34156	256	34422	259	35142	262	35505	266	36312	292	37139	231
34157	256	34423	259	35300	38	35506	266	36318	283	37140	231
34158	256	34424	259	35300	261	35507	266	36319	283	37141	231
34159	256	34425	259	35305	39	35508	266	36325	283	37142	231
34160	256	34426	259	35305	262	35510	266	36326	16	37143	231
34200	252	34428	259	35310	38	35511	266	36326	283	37144	231
34201	252	34429	259	35310	261	35512	266	36328	16	37145	231
34202	252	34439	258	35311	38	35514	266	36329	16	37148	282
34203	252	34440	258	35311	261	35515	266	36410	208	37149	282
34221	260	34441	258	35315	39	35516	266	37005	302	37150	282
34223	260	34442	258	35315	262	35517	266	37006	279	37151	282
34231	260	34443	258	35316	38	35518	267	37006	279	37152	282
34235	260	34445	258	35316	261	35519	267	37007	279	37153	282
34237	260	34446	258	35317	38	35524	267	37007	279	37154	282
34238	260	34447	258	35317	261	35525	267	37008	279	37155	280
34241	260	34448	259	35318	38	35527	267	37009	279	37156	280
34243	260	34449	258	35318	261	35532	267	37011	278	37157	280
34251	260	34450	258	35319	38	35533	267	37012	279	37158	282
34261	260	34451	258	35319	261	35539	267	37021	278	37162	281
34262	260	34452	259	35320	50	35540	267	37025	278	37166	273
34265	260	34453	258	35322	50	35542	267	37025	278	37170	281
34271	252	34454	258	35323	42	35552	267	37026	278	37171	281
34272	252	34455	259	35323	289	35553	267	37026	278	37172	281
34273	252	34456	259	35325	42	35555	267	37028	278	37173	282
34274	252	34457	259	35325	289	35603	269	37028	278	37174	282
34275	252	34458	259	35326	42	35604	269	37029	278	37175	281
34276	252	34480	258	35326	289	35605	269	37029	278	37176	281
34280	252	34481	258	35327	42	35833	52	37031	253	37177	282
34281	252	34482	258	35327	289	35845	52	37041	253	37178	282
34282	252	34485	258	35328	42	35850	52	37050	278	37185	281
34283	252	34486	258	35328	42	36014	276	37051	253	37186	281
34284	252	34490	259	35328	289	36024	276	37052	278	37187	281
34285	252	34491	259	35328	289	36034	276	37053	278	37188	281
34300	292	34496	259	35329	42	36035	276	37054	278	37189	281
34301	252	34500	260	35329	42	36036	276	37055	278	37190	281
34303	292	35006	263	35329	289	36046	276	37065	284	37192	281
34304	252	35007	263	35329	289	36056	277	37066	284	37195	282
34305	252	35011	264	35330	40	36057	277	37067	284	37196	282
34305	292	35012	263	35330	287	36058	277	37068	284	37197	282
34306	252	35013	263	35331	41	36059	277	37069	284	37198	282
34306	292	35015	264	35331	288	36076	275	37070	284	37199	282
34307	252	35021	264	35332	41	36077	275	37094	284	37200	280
34307	292	35023	262	35332	288	36080	275	37095	284	37201	280
34308	252	35038	262	35333	41	36081	275	37096	284	37202	280
34308	292	35048	264	35333	288	36082	275	37097	284	37203	280
34315	293	35058	262	35334	41	36085	275	37098	284	37204	280
34316	131	35059	263	35334	288	36086	275	37101	253	37205	280
34316	293	35068	264	35335	42	36087	275	37102	280	37210	280
34400	258	35069	263	35335	289	36102	275	37105	280	37211	280
34401	258	35070	263	35336	41	36103	275	37106	280	37212	280
34402	259	35078	263	35336	288	36105	275	37107	280	37216	291
34403	259	35079	263	35344	41	36126	277	37111	253	37217	291
34404	258	35081	263	35344	287	36128	277	37114	291	37218	291

kod produktu	str.	kod produktu	str.	kod produktu	str.	kod produktu	str.	kod produktu	str.	kod produktu	str.
37220	280	37344	236	38022	299	38949	224	39217	290	42179	353
37230	292	37345	236	38024	297	38950	290	39218	290	42180	354
37231	292	37350	235	38025	298	38951	290	39219	290	42181	354
37232	292	37500	267	38026	279	38952	290	39238	292	42182	354
37233	292	37501	267	38027	297	38953	290	39240	290	42185	354
37234	292	37505	267	38028	297	38954	290	39241	290	42186	354
37235	292	37506	267	38030	299	38955	224	39242	290	42187	354
37236	291	37509	268	38031	299	38956	224	39243	290	42188	354
37237	291	37510	268	38032	297	38957	224	39244	290	42190	224
37238	291	37511	268	38042	279	38958	224	39245	292	42190	354
37239	291	37512	268	38045	279	38959	224	40050	353	42201	355
37243	303	37515	268	38050	223	38960	224	40051	353	42202	355
37244	303	37516	268	38052	223	38961	224	40052	353	42203	355
37245	303	37517	268	38054	223	38963	226	40053	353	42207	355
37246	303	37518	268	38055	223	38964	225	40054	353	42208	355
37247	303	37527	268	38060	223	38965	225	40055	353	42209	355
37248	303	37530	268	38063	223	38966	225	40056	353	42210	355
37250	303	37532	268	38065	223	38968	224	40057	353	42211	355
37251	303	37533	268	38095	223	38969	226	40058	353	42212	355
37252	303	37539	269	38096	223	38970	290	40059	353	42213	355
37253	303	37541	269	38097	223	38971	290	40060	353	42214	355
37255	225	37545	307	38895	284	38972	226	40075	353	42217	355
37256	225	37546	307	38896	284	38973	226	40076	353	42218	355
37257	225	37549	210	38899	284	38975	226	40077	353	42219	355
37258	225	37553	212	38900	284	38980	224	40100	352	42220	355
37259	225	37560	209	38901	285	38981	224	40120	352	42221	355
37263	225	37564	269	38902	285	38985	226	41050	352	42228	355
37264	225	37570	192	38903	285	38990	225	41080	352	42229	355
37266	225	37570	209	38904	285	38991	225	41081	352	42230	355
37267	225	37611	53	38905	285	38995	225	41082	352	42244	355
37268	225	37615	53	38906	285	39000	296	41083	352	42248	355
37270	225	37616	53	38907	284	39001	296	41100	352	42249	355
37271	225	37647	218	38908	284	39002	296	41101	352	42251	355
37272	225	37660	306	38909	284	39003	296	41102	352	42252	355
37273	225	37730	53	38910	285	39005	296	41103	352	42253	355
37275	225	37731	53	38911	285	39010	296	41120	352	42255	355
37280	226	37732	53	38912	285	39012	296	41121	352	42256	355
37281	226	37733	53	38913	285	39014	296	41122	352	42257	355
37285	282	37740	53	38914	285	39020	296	41123	352	42260	355
37286	282	37741	53	38915	285	39021	296	41150	352	42261	355
37287	282	37744	53	38916	285	39045	296	41151	352	42312	291
37288	282	37745	53	38917	285	39065	296	41152	352	42312	354
37289	282	37746	53	38918	285	39090	296	41153	352	42365	222
37290	303	37747	53	38919	279	39145	296	42101	352	42366	222
37291	303	37750	53	38920	279	39165	296	42102	352	42367	222
37295	226	37751	53	38923	279	39190	296	42103	352	42368	222
37296	226	37760	53	38924	225	39192	296	42115	291	42420	291
37297	226	37761	53	38925	224	39192	323	42120	291	43050	358
37300	235	38000	298	38926	226	39193	296	42150	353	43058	358
37301	235	38001	297	38927	224	39193	323	42151	353	43060	358
37302	235	38002	298	38928	225	39194	223	42152	353	43068	358
37303	235	38003	298	38929	225	39195	223	42153	353	43071	358
37308	236	38004	299	38930	226	39196	223	42155	353	43072	358
37309	236	38005	299	38931	224	39197	223	42156	353	43077	358
37310	235	38006	298	38932	224	39198	223	42157	353	43082	358
37311	235	38007	298	38933	226	39199	223	42158	353	43083	358
37317	313	38008	298	38934	225	39200	223	42160	353	43084	358
37320	235	38009	298	38935	226	39201	223	42161	353	43086	358
37321	235	38010	298	38937	226	39202	223	42162	353	43087	359
37325	234	38012	297	38939	226	39203	223	42163	353	43089	359
37326	234	38013	297	38940	226	39204	223	42170	354	43090	359
37328	234	38014	299	38941	226	39205	223	42171	354	43094	359
37330	234	38014	299	38942	225	39206	290	42172	354	43097	358
37331	234	38015	299	38943	226	39207	290	42173	354	43098	359
37332	234	38016	299	38944	224	39208	290	42174	354	43099	359
37340	236	38017	299	38945	224	39210	290	42175	353	43300	347
37341	236	38018	299	38946	224	39212	290	42176	353	43301	347
37342	236	38020	298	38947	224	39214	290	42177	353	44041	322
37343	236	38021	299	38948	224	39216	290	42178	353	44042	322

REJESTR ARTYKUŁÓW



kod produktu	str.	kod produktu	str.	kod produktu	str.	kod produktu	str.	kod produktu	str.	kod produktu	str.
44043	322	45034	319	45099	310	45178	333	45268	335	45391	324
44050	322	45035	318	45100	334	45179	331	45269	335	45392	324
44053	319	45036	322	45101	334	45180	327	45270	39	45393	324
44950	131	45038	319	45102	334	45181	327	45271	39	45394	324
44950	315	45039	319	45104	334	45182	333	45280	334	45395	324
44955	319	45040	319	45105	334	45183	333	45283	334	45396	325
44960	323	45041	319	45106	334	45184	331	45285	334	45397	325
44965	338	45042	319	45107	334	45185	331	45286	334	45398	325
44970	313	45043	323	45108	334	45186	331	45287	334	45399	325
44971	313	45044	322	45110	326	45187	332	45289	329	45400	325
44972	310	45045	136	45111	327	45190	332	45290	329	45401	325
44980	310	45045	320	45112	327	45191	332	45291	329	45450	357
44980	310	45046	136	45113	327	45192	332	45292	329	45451	357
44980	311	45046	320	45114	327	45193	332	45293	329	45452	357
44981	310	45047	323	45115	327	45194	332	45294	328	45453	357
44981	310	45048	136	45116	326	45195	332	45295	328	45460	357
44981	311	45048	312	45117	326	45196	332	45296	328	45461	357
44981	311	45048	320	45118	326	45197	332	45297	328	45462	357
44982	310	45049	322	45120	327	45198	332	45298	328	45463	357
44982	310	45050	338	45122	327	45199	332	45299	328	45465	357
44982	311	45051	338	45123	326	45200	332	45300	333	45466	357
44983	310	45052	338	45124	326	45203	332	45301	333	45467	357
44983	310	45053	339	45125	326	45204	332	45320	339	45470	357
44983	311	45054	339	45126	326	45206	332	45321	339	45471	226
44984	311	45055	339	45130	329	45211	332	45323	337	45471	323
44984	312	45056	318	45131	329	45213	328	45323	348	45472	323
44984	312	45057	318	45132	329	45214	327	45325	337	45473	323
44985	311	45058	318	45133	329	45215	329	45326	337	45480	357
44985	312	45059	318	45134	330	45216	328	45326	337	45485	357
44991	311	45060	193	45135	329	45217	329	45327	337	45490	314
44992	311	45060	315	45136	329	45218	328	45328	337	45496	357
44995	314	45061	193	45137	329	45219	329	45329	337	45497	357
44996	312	45061	315	45138	328	45220	334	45330	337	45498	357
44997	312	45062	193	45139	328	45221	334	45330	350	45499	357
44998	312	45062	315	45140	328	45222	334	45331	337	45500	321
44999	313	45063	310	45141	328	45223	334	45331	350	45502	321
45000	314	45065	318	45142	328	45224	334	45341	333	45503	321
45001	314	45066	318	45143	328	45225	334	45342	333	45505	321
45002	314	45067	318	45144	329	45226	334	45343	333	45506	321
45003	314	45068	136	45145	329	45227	334	45344	333	45508	321
45005	314	45068	312	45146	330	45228	334	45345	333	45509	321
45006	314	45068	320	45147	331	45229	334	45346	333	45511	321
45007	314	45069	131	45150	331	45239	336	45347	333	45512	321
45008	314	45069	315	45151	331	45240	336	45348	333	45513	321
45009	314	45070	340	45152	330	45241	336	45349	333	45515	321
45010	312	45071	338	45153	330	45242	336	45350	333	45516	321
45011	313	45073	136	45154	330	45244	335	45351	333	45517	321
45012	313	45073	320	45155	330	45245	335	45352	333	45518	321
45014	312	45074	323	45156	331	45246	335	45353	333	45519	321
45015	313	45079	319	45158	330	45247	335	45354	333	45520	321
45016	313	45080	319	45159	331	45248	335	45370	136	45521	321
45017	311	45081	131	45160	331	45249	335	45370	320	45522	321
45018	312	45081	315	45161	331	45250	335	45372	325	45523	321
45019	312	45082	131	45162	330	45251	335	45372	333	45524	321
45020	310	45082	315	45163	330	45253	335	45373	325	45525	321
45021	312	45083	131	45164	331	45254	335	45373	333	45526	321
45023	310	45083	315	45167	330	45256	335	45374	325	45527	321
45025	313	45084	131	45168	331	45257	335	45374	333	45528	321
45026	312	45084	315	45169	331	45260	335	45375	325	45529	321
45027	313	45085	319	45170	336	45261	335	45375	333	45530	321
45029	313	45086	323	45171	336	45262	335	45376	325	45531	321
45030	193	45088	311	45172	336	45262	335	45376	333	45532	321
45030	315	45089	311	45172	336	45263	335	45377	325	45533	321
45031	193	45093	323	45173	336	45263	335	45377	333	45534	321
45031	315	45094	311	45173	336	45265	335	45385	324	45535	322
45032	193	45095	310	45174	333	45266	335	45386	324	45540	321
45032	315	45096	310	45175	332	45267	335	45388	324	45541	321
45033	193	45097	311	45176	333	45267	335	45389	324	45542	321
45033	315	45098	310	45177	333	45268	335	45390	324	45543	321

kod produktu	str.	kod produktu	str.	kod produktu	str.	kod produktu	str.	kod produktu	str.	kod produktu	str.
45550	321	45660	322	48094	49	50544	233	51244	227	52055	307
45551	321	45661	322	48095	49	50549	232	51245	227	52060	307
45552	321	45662	322	48096	49	50550	230	51246	227	52065	307
45553	321	45663	322	48097	49	50551	230	51247	227	52070	300
45555	322	45664	322	48410	306	50553	230	51258	227	52071	300
45556	321	45670	322	48411	306	50554	230	51259	227	52075	300
45557	321	45671	322	48415	306	50555	233	51260	227	52076	300
45558	321	45672	322	48420	306	50556	230	51261	227	52077	300
45559	321	45673	322	48452	307	50557	232	51262	227	52078	300
45560	322	48001	48	48453	307	50558	232	51264	227	52101	349
45562	321	48002	48	48454	307	50559	230	51271	227	52102	349
45563	321	48004	47	48455	307	50560	230	51272	227	52103	349
45564	321	48005	47	48456	307	50562	230	51273	227	52104	349
45565	321	48006	47	48457	307	50563	230	51274	227	52105	349
45570	354	48007	47	48719	273	50564	230	51275	227	52108	348
45571	354	48008	49	48729	269	50570	230	51276	227	52109	349
45572	354	48009	49	48730	269	50571	230	51278	227	52113	349
45573	354	48010	48	48731	269	50585	233	51280	227	52114	349
45580	354	48011	48	50030	355	50585	303	51281	227	52115	349
45600	334	48013	15	50031	355	50586	233	51282	227	52116	349
45601	334	48013	48	50032	355	50586	303	51283	227	52119	348
45602	334	48015	47	50033	355	50587	233	51284	227	52126	350
45603	334	48020	46	50035	228	50587	303	51286	227	52130	280
45604	334	48021	46	50035	355	50588	233	51287	227	52135	348
45605	334	48022	46	50036	228	50588	303	51288	227	52160	349
45606	334	48030	47	50036	355	51100	228	51300	227	52161	349
45607	334	48031	48	50037	355	51102	228	51301	227	52162	349
45608	334	48032	48	50038	355	51103	228	51302	227	52163	349
45609	334	48033	48	50040	355	51104	228	51303	227	52164	349
45610	334	48034	48	50041	355	51105	228	51304	227	52168	348
45611	334	48036	47	50042	355	51106	228	51305	227	52173	348
45612	334	48037	47	50050	222	51107	228	51306	227	52175	348
45613	334	48040	48	50050	222	51108	228	51307	227	52176	348
45614	334	48041	48	50051	222	51109	228	51308	227	52185	349
45615	334	48042	48	50052	222	51110	228	51320	227	52186	349
45616	334	48043	48	50052	222	51111	228	51321	227	52187	349
45617	334	48046	46	50100	227	51120	228	51322	227	52188	349
45618	334	48046	49	50101	227	51121	228	51323	227	52189	349
45619	334	48047	46	50102	227	51122	228	51324	227	52190	349
45620	334	48047	49	50103	227	51123	228	51325	227	52191	349
45621	334	48050	49	50104	227	51124	228	51327	227	52192	349
45622	334	48051	49	50106	227	51125	228	51341	227	52193	349
45623	334	48054	49	50108	227	51126	228	51402	228	52194	349
45624	334	48055	49	50500	233	51127	228	51403	228	52195	349
45625	334	48056	49	50503	233	51130	228	51404	228	52196	349
45626	334	48057	49	50510	230	51131	228	51405	228	52197	348
45627	334	48060	49	50511	230	51132	228	51406	228	52198	348
45628	334	48061	49	50512	230	51196	228	51407	228	52202	300
45629	334	48062	49	50513	230	51197	228	51408	228	52203	300
45630	334	48063	49	50514	230	51198	228	51410	228	52204	300
45631	334	48064	49	50518	232	51199	228	51412	228	52205	300
45632	334	48065	49	50519	232	51204	227	51413	228	52206	300
45633	334	48066	49	50520	232	51205	227	51414	228	52207	300
45634	334	48067	49	50522	232	51206	227	51415	228	52208	300
45635	334	48068	49	50524	232	51207	227	51416	228	52212	300
45636	334	48070	49	50525	232	51208	227	51417	228	52213	300
45637	334	48071	49	50526	232	51209	227	51418	228	52214	300
45638	334	48072	49	50527	233	51210	227	51420	228	52215	300
45639	334	48075	49	50529	232	51211	227	51430	228	52216	300
45650	322	48076	49	50531	233	51212	227	51431	228	52217	300
45651	322	48077	49	50532	233	51220	227	51432	228	52218	300
45652	322	48080	49	50533	232	51221	227	51433	228	52220	300
45653	322	48081	49	50535	232	51222	227	51435	228	52283	300
45654	322	48085	49	50536	232	51225	227	51436	228	52284	300
45655	322	48086	49	50537	232	51226	227	51450	228	52285	300
45656	322	48087	49	50539	232	51227	227	52011	249	52286	300
45657	322	48090	49	50540	233	51241	227	52011	303	52288	300
45658	322	48091	49	50541	233	51242	227	52030	252	52305	301
45659	322	48093	49	50542	233	51243	227	52050	307	52306	301

REJESTR ARTYKUŁÓW



kod produktu	str.	kod produktu	str.	kod produktu	str.	kod produktu	str.	kod produktu	str.	kod produktu	str.
52328	301	55356	229	61003	344	61098	345	61236	217	70025	44
52331	301	55357	229	61004	344	61098	351	61240	197	70026	44
52334	301	55358	229	61005	341	61111	346	61250	351	70030	44
52391	301	55359	229	61005	351	61112	346	61251	319	70031	44
52421	301	55360	229	61006	341	61114	346	61251	351	70032	44
52424	301	55361	229	61006	351	61120	346	61252	351	70033	44
52428	301	55362	229	61007	341	61121	346	61253	351	70035	44
52456	301	55400	356	61008	341	61130	338	61254	351	70036	44
52471	301	55401	356	61009	345	61131	338	61255	351	70037	44
52600	302	55402	356	61010	341	61132	339	61256	351	70040	43
52601	302	55403	356	61012	345	61133	339	61290	346	70060	44
52602	302	55404	356	61013	344	61134	339	61291	346	70061	44
52605	302	55405	356	61014	345	61135	339	61292	346	70062	44
52610	302	55406	356	61015	341	61141	339	61293	346	70063	44
52611	248	55420	356	61018	345	61142	340	61294	318	70064	43
52612	248	55421	356	61019	344	61143	340	61295	318	70065	44
52620	302	55422	356	61020	342	61144	340	61296	318	70066	43
52625	302	55423	356	61021	342	61145	340	61297	318	70070	44
52630	302	55424	356	61022	343	61146	340	61299	356	70075	44
52635	302	55425	356	61024	343	61150	338	61300	356	70090	45
52640	302	55429	356	61025	342	61155	341	61301	356	70091	45
52645	302	55430	356	61026	342	61156	341	61302	356	70092	45
52652	302	55431	356	61027	343	61157	341	61320	197	70093	45
52656	302	55432	356	61028	345	61158	341	61321	197	70094	45
52662	302	55433	356	61029	341	61161	344	61322	197	70095	45
52666	302	55436	356	61030	340	61162	344	61323	197	70096	45
52671	302	55437	356	61031	340	61163	344	61324	197	70098	210
52694	302	55450	356	61032	340	61164	345	61325	197	81011	361
52695	302	55452	356	61033	340	61165	345	61326	197	81012	361
54008	303	55453	356	61034	340	61166	345	61327	197	81013	361
55040	229	55454	356	61035	346	61169	251	61328	197	81014	361
55050	229	55455	356	61036	346	61171	350	61329	197	81015	361
55051	229	55456	356	61038	346	61172	348	61330	197	81016	361
55060	229	55457	356	61040	346	61172	350	61331	197	81022	361
55080	229	55460	356	61042	346	61173	350	61340	317	81023	361
55100	229	55461	356	61044	345	61174	350	61341	317	81024	361
55120	229	55462	356	61045	340	61175	350	61342	317	81025	361
55140	229	55465	356	61046	340	61176	350	61343	317	81035	361
55160	229	55640	229	61047	340	61177	350	61344	317	81036	361
55180	229	55642	229	61048	340	61183	351	61345	317	81053	364
55181	229	55645	229	61050	342	61184	351	61346	317	81054	364
55200	229	55650	229	61050	351	61189	351	65062	307	81057	364
55201	229	60001	347	61051	342	61190	351	65063	307	81070	364
55220	229	60006	347	61051	351	61192	350	65064	307	81071	364
55221	229	60008	347	61052	343	61193	350	65065	307	81077	364
55240	229	60012	347	61052	351	61194	350	69900	294	81100	364
55300	229	60018	347	61053	343	61195	351	69901	294	81101	364
55315	229	60019	347	61054	343	61200	350	69902	294	81102	364
55316	229	60020	347	61056	342	61201	347	69903	294	81103	364
55317	229	60022	347	61057	342	61201	350	69904	295	81104	364
55318	229	60100	251	61058	343	61202	350	69905	294	81105	364
55319	229	60115	273	61059	343	61203	345	69906	294	81106	364
55331	229	60116	273	61060	340	61204	351	69907	295	81150	362
55332	229	60117	273	61061	340	61205	351	69908	295	81151	362
55333	229	60118	273	61062	340	61207	351	69909	295	81152	362
55334	229	60121	273	61063	340	61208	350	69910	295	81155	362
55335	229	60123	273	61067	346	61209	345	69911	295	81160	362
55336	229	60125	272	61068	346	61215	351	69912	295	81165	362
55337	229	60130	272	61069	346	61218	251	69914	294	81170	362
55339	229	60132	272	61070	346	61219	351	69917	295	81175	362
55340	229	60155	272	61077	351	61221	318	69918	294	81178	362
55341	229	60157	272	61079	351	61221	318	69919	294	81180	362
55342	229	60201	347	61079	351	61221	318	69920	295	81185	362
55350	229	60206	347	61085	319	61221	318	69923	295	81186	362
55351	229	60208	347	61088	342	61222	345	69928	295	81188	362
55352	229	60212	347	61089	342	61223	344	69930	296	81189	362
55353	229	61000	342	61090	343	61224	346	69931	296	81190	362
55354	229	61001	342	61097	344	61224	346	70020	44	81191	362
55355	229	61002	343	61097	351	61230	351	70021	44	81195	361

kod produktu str.	kod produktu str.	kod produktu str.	kod produktu str.	kod produktu str.	kod produktu str.				
81196	361	81267	363	81337	363	81408	363	82103	307
81197	361	81268	363	81338	363	81409	363	82104	307
81200	363	81269	363	81339	363	81410	363	89775	51
81201	363	81270	363	81340	363	81411	363	89970	51
81202	363	81271	363	81341	363	81412	363	89973	51
81203	363	81272	363	81342	363	81413	363	89975	51
81204	363	81273	363	81343	363	81414	363	89980	51
81205	363	81274	363	81344	363	81415	363	89985	51
81206	363	81275	363	81345	363	81416	363	89987	51
81207	363	81276	363	81346	363	81417	363	89988	51
81208	363	81277	363	81347	363	81418	363	89989	51
81209	363	81278	363	81348	363	81419	363	89990	51
81210	363	81279	363	81349	363	81420	363	90070	278
81211	363	81280	363	81350	363	81421	363	90071	278
81212	363	81281	363	81351	363	81422	363	90072	278
81213	363	81282	363	81352	363	81423	363	90191	56
81214	363	81284	363	81353	363	81424	363	90192	57
81215	363	81285	363	81354	363	81425	363	18610A	150
81216	363	81286	363	81355	363	81426	363	18611A	150
81217	363	81287	363	81356	363	81427	363	18612A	150
81218	363	81288	363	81357	363	81428	363	18613A	150
81219	363	81289	363	81358	363	81429	363	18614A	150
81220	363	81290	363	81359	363	81430	363	18615A	150
81221	363	81291	363	81360	363	81431	363	18632A	147
81222	363	81292	363	81361	363	81432	363	18633A	147
81223	363	81293	363	81362	363	81433	363	18636A	147
81224	363	81294	363	81363	363	81434	363	18637A	147
81225	363	81295	363	81364	363	81435	363	18638A	147
81226	363	81296	363	81365	363	81436	363	18827A	147
81227	363	81297	363	81366	363	81437	363	18828A	147
81228	363	81298	363	81367	363	81438	363	18830A	147
81229	363	81299	363	81370	363	81439	363	18831A	147
81230	363	81300	363	81371	363	81440	363	81011A	361
81231	363	81301	363	81372	363	81441	363	81011F	361
81232	363	81302	363	81373	363	81442	363	81011G	361
81233	363	81303	363	81374	363	81443	363	81011H	361
81234	363	81304	363	81375	363	81444	363	81011R	361
81235	363	81305	363	81376	363	81445	363	M90203	365
81236	363	81306	363	81377	363	81447	363	M90204	365
81237	363	81307	363	81378	363	81448	363	M90205	365
81238	363	81308	363	81379	363	81449	363	M90206	365
81239	363	81309	363	81380	363	81450	363	M90207	365
81240	363	81310	363	81381	363	81451	363	M90210	365
81241	363	81311	363	81382	363	81452	363	M90220	365
81242	363	81312	363	81383	363	81453	363	M90221	365
81243	363	81313	363	81384	363	81454	363	M90222	365
81244	363	81314	363	81385	363	81455	363	M90400	365
81245	363	81315	363	81386	363	81456	363	M90403	365
81246	363	81316	363	81387	363	81457	363	M90519	365
81247	363	81317	363	81388	363	81458	363		
81248	363	81318	363	81389	363	81459	363		
81249	363	81319	363	81390	363	81460	363		
81250	363	81320	363	81391	363	81461	363		
81251	363	81321	363	81392	363	81462	363		
81252	363	81322	363	81393	363	81463	363		
81253	363	81323	363	81394	363	81466	363		
81254	363	81324	363	81395	363	81467	363		
81255	363	81325	363	81396	363	81468	363		
81256	363	81326	363	81397	363	81469	363		
81257	363	81327	363	81398	363	81470	363		
81258	363	81328	363	81399	363	81471	363		
81259	363	81329	363	81400	363	81472	363		
81260	363	81330	363	81401	363	81473	363		
81261	363	81331	363	81402	363	81486	363		
81262	363	81332	363	81403	363	81600	364		
81263	363	81333	363	81404	363	81603	364		
81264	363	81334	363	81405	363	82100	307		
81265	363	81335	363	81406	363	82101	307		
81266	363	81336	363	81407	363	82102	307		

LISTA UZYWANYCH PIKTOGRAMÓW

· SPECYFIKACJA PRODUKTU

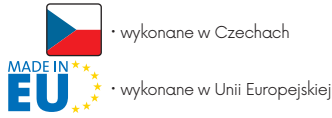

SPECYFIKACJE APLIKACJI ·

- drewno ·
- ceramika ·
- plastik ·
- aluminium ·
- miedź ·
- kamień ·
- szkło ·
- mur ·
- papier ·
- zelazo ·
- kompozyt ·
- plytki ·
- stal nierdzewna ·
- tynk ·
- drewno za pomocą śrub, gwoździ ·
- plyta gipsowa ·
- do wiercenia w materiałach o wytrzymałości na rozciąganie do ...

- S2** · materiałowy skład produktu - stal narzędziowa S2
- HSS** · materiałowy skład produktu - stal szybko tnąca
- Cr-Mo** · materiałowy skład produktu - stal chromowo-molibdenowa
- CrV** · materiałowy skład produktu - stal chromowo-wanadowa
- INOX** · materiałowy skład produktu - stal nierdzewna
- NYLON** · nylonowy uchwyt
- TEFLON** · powierzchnia teflonowa
- Zn** · powierzchnia ocynkowana
- TiN** · powierzchnia pokryta azotkiem tytanu
- HRC 58-61** · HRC - twardość materiału
- 40% PES** · procentowa zawartość materiału - 40% poliestru
- PES** · zawartość materiału - poliestru
- obróbka powierzchni diamentowa
- produkt lub część produktu jest magnetyczna

- SDS+** · typ mocowania
- SDS MAX** · typ mocowania
- M14** · typ mocowania
- 72T** · liczba zębów w grzechotce
- 36T** · liczba zębów w grzechotce
- 1/2"** · rozmiar
- 3/4"** · rozmiar
- 1/4"** · rozmiar
- 27 dB** · podatak o zašiti od buki
- DIN 3113** · norma
- IP 54** · norma
- 32x** · liczba sztuk w opakowaniu
- II. class** · klasa dokładności
- III. class** · klasa dokładności
- nadaje się na chłodne dni
- ergonomiczny uchwyt
- HOBBY** · hobby
- 2x AAA** · rodzaj i liczba potrzebnych baterii
- UV STABLE** · UV stabilny
- RUBBER ENDS** · gumowe końcówki odporne na uderzenia



· PAKOWANIE

- zapakowane w pudełko
- eurosłot
- MOQ 12** · minimalna ilość zamówienia
- 5** · ilość sztuk w paczce

SPECYFIKACJE PRODUKTÓW FESTA AQUATIC A ROSA ·

regulowane wzory natrysku ·

- minimalne i maksymalne ciśnienie wody · **2bar min** / **4bar max**
- maksymalny protok wody · **Max 27L/min**
- obszar nawadniany · **318 m²**
- rozmiar gwintu adaptera · **1/2"**
- średnica węży do złącza · **1/2"**



20

25

26

FESTA

PROFESJONALNE  NARZĘDZIA



festatools



#festatools



festatools

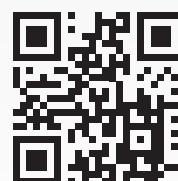

www.festa.tools

HORIZONT.

FESTA
POWER X TOOLS

FESTA
AQUATIC

ROSA KOMELON.

KDS

Stahlberg

SUPER PRO

Lescha

