

Air compressor

Item number: 28075

Model No.: PLQEL-816-20V



Manual for use



Please read this manual carefully before using.

PARTS LIST AND SCHEMATIC DIAGRAM

- A. Digital display
- B. Start switch
- C. Set button
- D. Light switch
- E. Tire pressure increase/decrease button
- F. Rubber cover handle
- G. Battery
- H. LED lighting
- I. Switch
- J. Air hose buckle
- K. Air hose
- L. Air chuck
- M. Nozzle interface storage area
- N. Cigarette lighter charging line

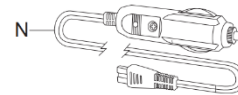
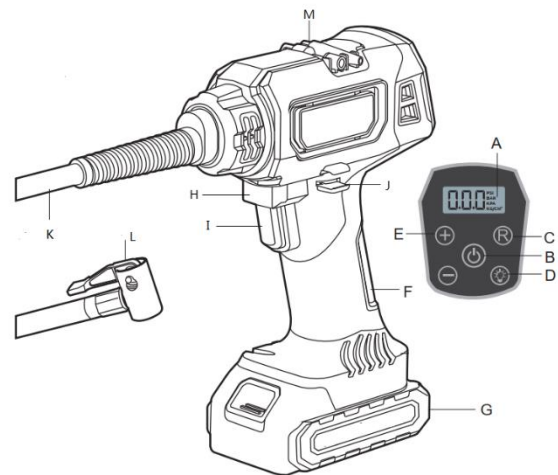

Fig.1

Rated voltage	20 V – Li-ion battery powered 12 V – Car lighter powered
Max air pressure	120 PSI/8,2 bar
Air hose length	60 cm

SPECIFICATIONS

Great for Car/RV/SUV/Light Truck Tires and small inflatables
 Cordless design, easy to carry
 Comes with nozzle accessories
 Operate with 20V battery or 12V power cord

INCLUDE

1-Ball Nozzle, 1-Tire Valve Nozzle, 1-Air Bed Nozzle, 1-Fuse
 12V Cigarette lighter charging line

BATTERY PACK



1. The battery is not fully charged. Please charge the battery for 3-5 hours before the first use. The battery is completely exhausted. The normal charging time is 3-5 hours. Please unplug the charging wire in time after full charging.
2. When the performance of the tool begins to decline, replace the new battery; Extreme heat is the most destructive to the battery; Heat generated. The more the amount, the faster the battery loses power, and the overheating of the battery will shorten the service life.

3. When using the tool, even after the tool has good performance, do not discharge excessively, and the battery power is reduced, When the performance of the tool begins to decline, please stop the tool and charge the battery for the best performance.

HOW TO INSTALL THE BATTERY

Step 1:

Install battery pack or 12V car power adapter

■ install or remove the battery pack

(Figure 2)

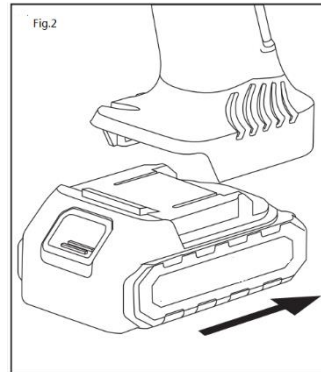

To install:

Slide the battery pack into the bottom until you hear a click. Make sure that the latch is in place and battery is secure before operation.

To remove:

Pull out the battery pack while pressing the battery release latch.

install or remove 12V car power adapter

(Figure 3)

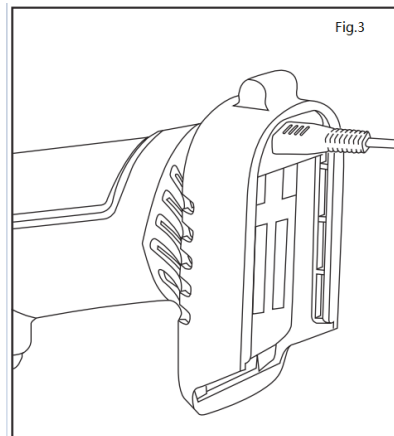

1. Unravel cord before using. If the battery is installed, remove it from the machine first by pressing battery release button and pulling out.
2. Plug the 12V car power adapter into the machine.
3. Connect the adapter into the car socket. When ready to use, power car on.

Step 2:

Connect the Air Chuck to the Valve Stem

1. Push the air chuck clamp up so that it is in the unlock position.
2. Then place the air chuck on the valve stem and make sure the threaded section of the valve stem is inside the air chuck.
3. Pressing air chuck clamp down until it stops or is parallel with the air hose.

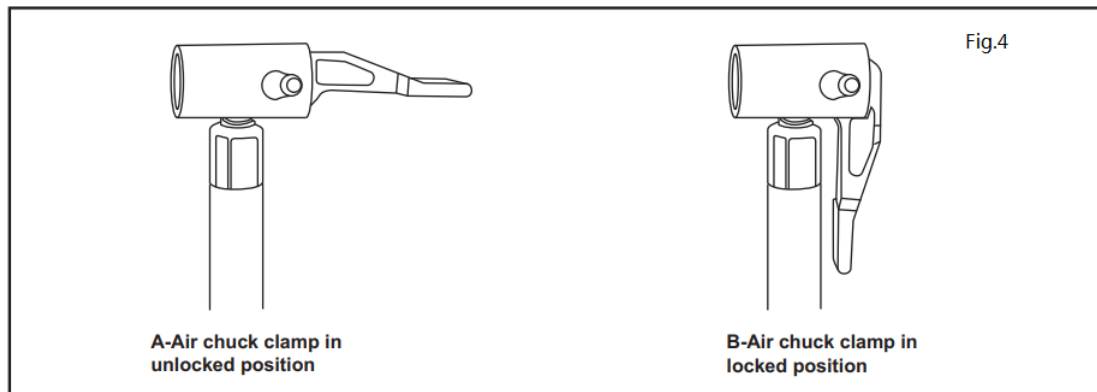

Note:

Improperly connected hoses or accessories may separate under pressure and pressure and cause serious injury.



Possible air leaks can cause incorrect pressure readings. Ensure that all connections are secure.

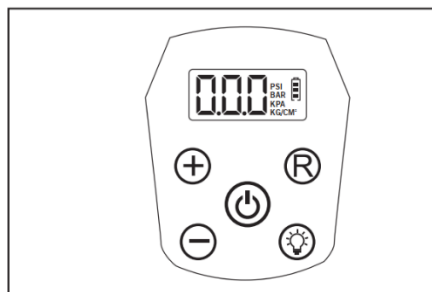

Note:

When using the inflator, make sure that the hose is free of obstacles. If the hose is blocked, it may be overheated.

Step 3: set the pressure value



1. Press the "  " (on / unit) button to read the current tire pressure on the gauge.
2. Press the "  " button again to select the tire pressure measurement unit from PSI, KPA, BAR, KG/CM.
3. Press the "+" or "-" button to adjust the preset tire pressure. (1) Long press the "+" or "-" button to quickly adjust the working pressure. (2) Short press the "+" or "-" button to adjust the preset working pressure.
Note: increment by 0.05BAR & KG/ CM, 0.5PSI, 5KPA.
4. The preset pressure value will be set after three seconds.
5. Press the start switch to inflate. When it reaches the preset pressure value, the inflator will stop working.

6. Press the "  " button (on / unit), then press the "  " button, the LED light is turned on. And press the "  " button again, the LED light will be turn off.

Note: the tolerance of inflator is + or - 2 psi. If it is used continuously every 10 minutes, a cooling time of 3 minutes is required.

1. To reset the tire pressure measurement unit press "  " to reselect after setting preset pressure value.;
2. The digital gauge records the preset measurement unit and the value of the last operation;
3. After the air pump reaches the preset pressure value, the digital gauge will automatically shut down after 60 seconds;
4. The maximum pressure is 120 psi.

Note:

1. Since the pressure gauge is not calibrated and not binding for exact values, tire pressure must be checked by using a reliable measuring device after inflating tires with this pump. Driving a vehicle with improperly inflated tires could result in serious injury.
2. Do not leave items that being pumped up unattended while using the inflator. These items can burst and could cause serious injury.
3. The inflator is capable of inflating up to 6.8 Bar. To avoid over inflation, carefully follow instructions on items to be inflated. To avoid product damage, never exceed recommended pressures.
4. The inflator is not designed for commercial applications.

Storage of air hoses and accessories

When the inflator is not used, put the hose into the storage area on both sides of the tool. The adaptors and needles provided with the inflator can also be placed in the storage area.

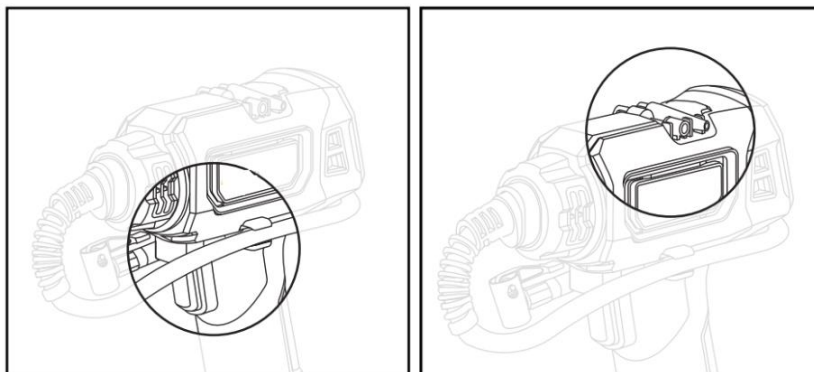

FUNCTION AND OPERATION INSTRUCTIONS

Parts

The accessories provided have a variety of functions: the conical adapter can be used on the smaller pinch valve to inflate small items such as children's toys. Usually, the user needs to blow air to inflate them. The sports ball needle can be used to inflate various types of balls or any other items that need to inflate the sports ball needle.

Note: when inflating items of 10 psi or less, after each burst of short-term continuous inflation, check by feeling or using a calibrated measuring device to determine the accurate pressure.

How to install the ball needle

For inflating sport balls like basketball, football, etc.

The following pictures show to hoop up the nozzle to air chuck.

Note: do not completely insert the ball needle into the air chuck to prevent the exhaust needle hole from being completely blocked.

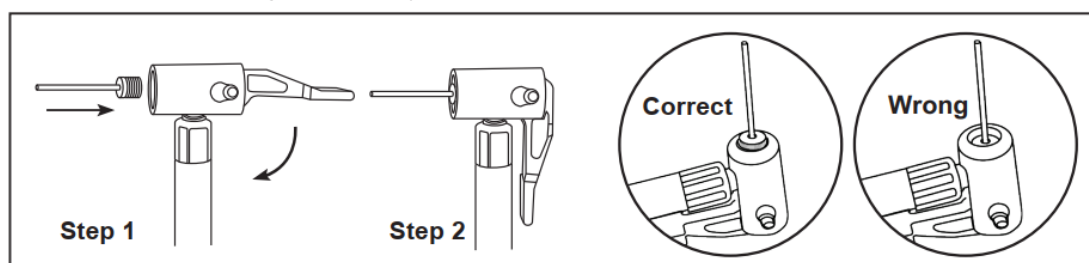

Replace the cigar lighter fuse

If the cigar lighter can not provide power for the inflator, check the fuse and see if it is broken.

As shown below, unscrew the head of the cigar lighter, take out the broken fuse, replaced by the new fuse, and screw the head.

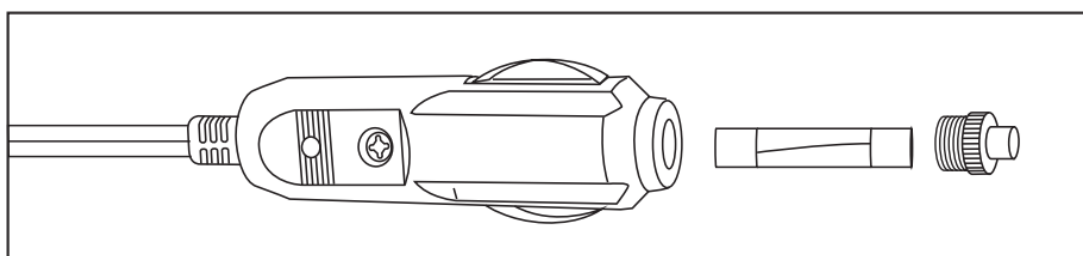

PRODUCT MAINTENANCE

1. Do not let brake fluid, gasoline, petroleum products, penetrating oil, etc. contact with plastic parts. Chemicals may damage, weaken or break bad plastic, resulting in serious machine injury.
2. Wipe the surface of the machine with a soft wet cloth to keep the surface of the inflator clean. Do not use solvents on plastic parts. When cleaning plastic parts, avoid using solvents. Most plastics are easily damaged by various irritating solvents and can be damaged due to use. Use clean cloth to remove dirt, dust, oil, grease, etc.

3. In order to maintain the best performance of the rechargeable battery, please prevent the battery from overheating, including overcharging and storage, and do not use the machine for a long time. The battery is charged for 7 hours every three months.

IMPORTANT SAFETY INSTRUCTIONS

Read and understand all instructions. Failure to follow all instructions listed below may result in electric shock, fire or serious personal injury.



When using electrical appliances, basic precautions should always be taken and observed, including the following.

ELECTRICAL SAFETY

1. To reduce the risk of electrical shock, do not put inflator in water or other liquid. Do not place or store appliance where it can fall or be pulled into a tub or sink.
2. Use this product only with batteries and chargers.

PERSONAL SAFETY

1. When operating the inflator, keep alert, observe what you are doing, and use common sense. Do not use the inflator when you are tired or under the influence of drugs, alcohol or drugs.
Inattention when operating the inflator may cause serious personal injury.
2. When operating the inflator, always maintain a proper foothold and balance. The correct foothold and balance can better control the inflator in unexpected situations.
3. Goggles shall be worn during use, and dust-proof masks, anti-skid safety shoes, hard hats or hearing protection devices must be used if necessary.
4. Do not wear loose clothes and keep long hair. Loose clothes, jewelry or long hair may be sucked into the air inlet, causing wind blockage and even damaging the machine.
5. Do not use on ladders or unstable supports. A stable foothold on a solid ground can better control the inflator in case of accidents.
6. Do not disassemble the inflator. Do not operate the inflator near flammable liquid or in gas or explosive environment. Internal sparks may ignite smoke.
7. Do not store the inflator in a humid or high-temperature environment. Do not store at a temperature below 10 ° C or above 35 ° C.

USE AND MAINTENANCE OF INFLATOR

1. Before each use, check whether the hose is fragile or worn to ensure that all connections are secure. Do not use if defects are found. Purchase new hoses or notify an authorized service center for inspection or repair.
2. Slowly release all pressure in the system, dust and debris may be harmful. If the switch cannot be opened or closed, do not use the inflator. The inflator that cannot be controlled by the switch is dangerous and must be repaired.
3. Before making any adjustment, replacing accessories or storing the inflator, please put the switch in the off position. Such preventive safety measures can reduce the risk of accidentally starting the inflator.

4. Store idle inflators out of reach of children and other untrained personnel. Inflators are dangerous in the hands of untrained users.
5. Check whether the moving parts are misaligned or stuck, whether the parts are broken and any other conditions that may affect the operation of the inflator. If damaged, please repair the inflator before use. Many accidents are caused by poorly maintained tools.
6. Use only accessories recommended by the manufacturer for your model. Accessories suitable for one inflator may cause injury risk when used on another inflator.
7. Keep the inflator and its handle dry, clean and free of grease. Always use clean cloth when cleaning. Never use brake fluid, gasoline, petroleum products or any strong solvent to clean the inflator. Following this rule will reduce the risk of loss of control and deterioration of the shell plastic.
8. Do not point any inflator at yourself or others.
9. Do not exceed the pressure rating of any component in the system.
10. Protect material and air lines from damage or puncture. Keep hoses and power cords away from sharp objects, chemical leaks, oil, solvents and wet floors.





SAFETY PRECAUTIONS FOR INFLATOR

1. Only qualified maintenance personnel can repair the inflator. Repair or maintenance by unqualified personnel may cause injury risk. Only use the same replacement parts when servicing the inflator.
Follow the instructions in the maintenance section of this manual. The use of unauthorized parts or non-compliance with maintenance instructions may result in the risk of electric shock or injury.
2. Understand your inflator, carefully read the operation manual, understand its application and limitations, and specific potential hazards related to this tool. Following this rule will reduce the risk of electric shock, fire or serious injury.
3. Explosion risk: do not operate the inflator so that the output pressure is greater than the marked maximum pressure of the object to be inflated. Do not use it under a pressure greater than 6.8 PA.
4. In order to reduce the risk of electric shock, do not get wet and store indoors.
5. Check the device for cracks, pinholes or other defects that may make the inflator unsafe. Do not cut or drill holes on the inflator.
6. Ensure that there is no obstacle or hose winding in the hose. Do not block the inflation or deflation outlet during operation, which may cause the inflator to lose balance and damage the machine.
7. Use the inflator only for its intended use and do not change or modify the original design or function of the device.
8. Be careful that misuse and improper operation of this inflator may cause injury to yourself and others. Do not leave the inflator unattended when the air hose is connected to the inflator.
9. Do not continue to use the inflator or hose with air leakage or abnormal function.
10. When adjusting, repairing or not using the inflator, be sure to disconnect the air source and power supply.

11. Do not attempt to pull or carry the inflator through the hose.
12. In addition to all safety rules of the inflator, all safety regulations recommended by the inflator manufacturer must be observed. Following this rule will reduce the risk of serious personal injury.
13. This product is only for family use, not for industrial production.
14. Do not use the inflator as a breathing device, do not spray compressed air onto people or animals, and do not blow dust and dirt to yourself or others. Following this rule will reduce the risk of serious injury.
15. Protect the lungs. If there is dust during operation, please wear a mask or dust mask. Following this rule will reduce the risk of serious personal injury.
16. Do not use this inflator to spray chemicals. Toxic fumes or chemicals may damage the parts of the inflator.
17. Burst risk: carefully monitor the object during inflation to reduce the risk of over inflation. During inflation, use reliable pressure gauge regularly. The pressure gauge on the inflator is only for reference, so it has no binding force on the accurate value.
18. Keep these instructions: always refer to them and use them to guide others who may use this inflator. If you lend this inflator to others, I will also lend them these instructions.

Meaning of symbols on label



	Use certified eye and ear protection with a sufficient level of protection.
	Read the instruction before use.
	Meets relevant EU requirements.
	DC current/ voltage
	Electrical waste, see below.

Waste disposal

PACKAGING

- Dispose of the packaging in the appropriate waste container.

CORDLESS POWER TOOLS



According to the European Directive (EU) 2012/19, electrical and electronic equipment may not be disposed of as mixed waste, but it is necessary to return them for ecological disposal to the return of electrical equipment at designated collection points. Before returning the cordless tool, remove the battery, which must be disposed of in an environmentally friendly manner separately. You will receive information about collection points at the municipal office.

BATTERY



The battery contains cartridges that are dangerous for the environment, so return it to the batteries for ecological recycling / disposal. According to the European Directive on Accumulators and Batteries 2006/66 EC, unusable batteries must not be disposed of with mixed waste or the environment. You will receive information about collection points at the municipal office.

EC Declaration of Conformity

Manufacturer Levior s.r.o., Tovačovská 3488, CZ-750 02 Přerov declares that the subsequently marked devices, based on their concept and construction, as well as the designs listed on the market, meet the requirements of the European Union listed below. This declaration is issued under the sole responsibility of the manufacturer.

Subjects of declaration-product identification:

Product: Air compressor

Model No.: PLQEL-816-20V

Item No.: 28075

comply with the following harmonized standards, including their amending annexes, if any, by which conformity with the following harmonization provisions is declared:

2006/42/EC:

EN ISO 12100:2010

(EU)2014/30

EN IEC 55014-1:2021

EN IEC 55014-2:2021

The completion of technical documentation 2006/42/EC and (EU)2014/30 was performed by Ondřej Marek with his registered office at the manufacturer's address.

The technical documentation (2006/42/EC) and (EU)2014/30 is available at the manufacturer's address.

Place and date of issue of the EC declaration of conformity: Přerov, 15.12. 2023

Person authorized to draw up the EC declaration of conformity on behalf of the manufacturer (signature, name, function):

**LEVIOR** s.r.o.
Tovačovská 3488/28, 750 02 Přerov
IČO 81973939 DIČ CZ61973939
tel.: 581 746 256-8, fax: 581 746 255

Ondřej Marek

managing director Levior s.r.o.